



Midlands Regional Office & Corporate Headquarters P.O. Box 8147 Columbia, SC 29202-8147  
Phone (803) 779-2078 Fax (803) 779-2079 www.allianceCE.com

To: Mr. Justin Koon, Manager  
Solid Waste Permitting & Monitoring Section  
Bureau of Land and Waste Management  
2600 Bull Street  
Columbia, South Carolina 29201

Date: October 11, 2019  
Project: Vertical and Horizontal Expansion of the  
Greenpointe Class II C&D Landfill in  
Anderson County, South Carolina  
Project No.: 16227-0004

Attached are the following items:

- Plans       Specifications       Reports       Calculations       Permit Application  
 Shop Drawings       \_\_\_\_\_

COPIES	DESCRIPTION	CODE
3	Construction Plans (Drawing No. 01,1168 -D21 dated June 2019)	2
3	Landfill Expansion Permit Application for the Greenpointe Class Two C&D Landfill dated October 2019	2

These are transmitted as indicated below:

1. For your information and file      2. For your review and approval      3. Approved  
4. Furnish as corrected, forward three (3) corrected copies      5. Revise and submit      6. Rejected

Justin,

Please see enclosed the three (3) copies of the Construction Plans and Permit Application for the Greenpointe Class Two

C&D Landfill Expansion for your review and approval. Please let us know if you have any questions or comments.

**ALLIANCE CONSULTING ENGINEERS, INC.**

CC: Mr. Deepal S. Eliatamby, P.E., Alliance Consulting Engineers, Inc.      BY: Ryan T. Ohmer  
Mr. Kyle M. Clampitt, P.E., Alliance Consulting Engineers, Inc.

Bluffton, SC | Charleston, SC | Charlotte, NC | Columbia, SC | Greenville, SC

RECEIVED

OCT 14 2019

DIVISION OF MINING  
SOLID WASTE MANAGEMENT  
BLWM

RECEIVED

OCT 14 2019

DIVISION OF MINING  
SOLID WASTE MANAGEMENT  
BLWM

PERMIT APPLICATION  
FOR THE  
GREENPOINTE CLASS TWO  
CONSTRUCTION, DEMOLITION AND LAND-CLEARING  
DEBRIS (C&D) LANDFILL EXPANSION

**Wasteco, Inc.**

OCTOBER 2019

PERMIT APPLICATION  
FOR THE  
GREENPOINTE CLASS TWO  
CONSTRUCTION, DEMOLITION AND LAND-CLEARING  
DEBRIS (C&D) LANDFILL EXPANSION

**Wasteco, Inc.**

Prepared For:  
Wasteco, Inc.  
Post Office Box 8028  
Greenville, South Carolina 29604

**ALLIANCE**  
CONSULTING ENGINEERS

Prepared By:  
Alliance Consulting Engineers, Inc.  
124 Verdae Boulevard, Suite 505  
Greenville, South Carolina 29607

Project No. 16227-0004  
October 2019



**TABLE OF CONTENTS**

1.0 INTRODUCTION..... 1

    1.1 Topography ..... 6

    1.2 Floodplains ..... 6

    1.3 Wetlands..... 9

2.0 PERMIT APPLICATION REQUIREMENTS ..... 11

    2.1 Demonstration of Need ..... 11

    2.2 Consistency Determination ..... 11

    2.3 Permit Application ..... 14

    2.4 Financial Assurance and Disclosure Statement ..... 14

    2.5 Construction Plans ..... 15

    2.6 Contiguous Properties ..... 15

    2.7 Tonnage Limit ..... 15

    2.8 Coastal Zone Management ..... 17

3.0 LANDFILL COVER AND STABILIZATION PLAN ..... 18

    3.1 Source of Cover Material ..... 18

    3.2 Frequency of Cover..... 18

    3.3 Depth of Disposal Area ..... 18

    3.4 Final Contour..... 21

    3.5 Stabilization Plan ..... 21

4.0 OPERATING PLAN..... 23

    4.1 Landfill Capacity and Life Expectancy..... 23

    4.2 Waste Screening ..... 23

    4.3 Control of Stormwater Drainage..... 25

    4.4 Fire Prevention ..... 27

    4.5 Vector Control ..... 27

    4.6 Odor Control..... 28

    4.7 Dust Control ..... 28

    4.8 Litter Control ..... 28

    4.9 Hours of Operation ..... 28

    4.10 Waste Placement..... 29

    4.11 Fill Progression Plan ..... 29

    4.12 Elevation Control..... 30

    4.13 Potential Disposal Materials..... 30

5.0 CONTINGENCY PLAN ..... 31

5.1 General Information ..... 31

5.2 Greenpointe C&D Landfill Emergency Coordinators..... 31

5.3 Equipment ..... 32

5.4 Implementation..... 32

5.5 Financial Feasibility..... 32

5.6 Emergency Response Procedures ..... 32

5.7 On-Site Accident/Injury Response..... 33

5.8 Fires within the Landfill..... 33

5.9 Spills or Material Release..... 34

5.10 Unauthorized Hazardous and Infectious Waste in Landfill..... 36

5.11 Inoperable Landfill Periods ..... 36

5.12 Prevention of Recurrence ..... 37

5.13 Emergency Equipment..... 37

5.14 Evacuation Plan ..... 37

5.15 Report Requirements..... 38

6.0 MONITORING AND REPORTING REQUIREMENTS ..... 39

6.1 Groundwater Monitoring..... 39

6.2 Corrective Action Implementation..... 39

6.3 Contingency Plan Implementation..... 39

6.4 Daily Records ..... 39

6.5 Annual Progress Report ..... 41

6.6 Permit Review ..... 41

7.0 CLOSURE..... 42

7.1 Final Cover Application ..... 42

7.2 Grassing..... 42

7.3 Signage..... 42

7.4 Verification of Closure..... 42

7.5 Corrective Action Plan ..... 43

7.6 Record of Facility ..... 43

8.0 POST CLOSURE CARE PLAN..... 44

8.1 General ..... 44

8.2 Inspection and Maintenance of Final Cover..... 44

8.3 Inspection and Maintenance of Stormwater/Sediment Controls..... 44

**LIST OF EXHIBITS**

EXHIBIT A – SITE LOCATION MAP ..... 2  
EXHIBIT B – AERIAL MAP ..... 3  
EXHIBIT C – EXISTING SITE MAP ..... 4  
EXHIBIT D – PROPOSED SITE MAP ..... 5  
EXHIBIT E- TOPOGRAPHIC MAP ..... 7  
EXHIBIT F – FEMA MAP ..... 8  
EXHIBIT G – NWI MAP ..... 10  
EXHIBIT H – ZONING MAP ..... 13  
EXHIBIT I – TAX MAP ..... 16  
EXHIBIT J – POTENTIOMETRIC MAP ..... 40

**LIST OF TABLES**

TABLE 1 – GROUNDWATER ELEVATIONS ..... 20  
TABLE 2 – GRASSING SCHEDULE ..... 22

**LIST OF ATTACHMENTS**

- ATTACHMENT 1 - TOPOGRAPHIC SURVEY
- ATTACHMENT 2 - WETLANDS DELINEATION AND SURVEY
- ATTACHMENT 3 - DEMONSTRATION OF NEED
- ATTACHMENT 4 - OPERATIONAL LIFE CALCULATIONS
- ATTACHMENT 5 - DETERMINATION OF CONSISTENCY LETTER
- ATTACHMENT 6 - APPLICATION FOR PERMIT TO CONSTRUCT A SOLID WASTE MANAGEMENT SYSTEM
- ATTACHMENT 7 - CLOSURE AND POST-CLOSURE CARE ESTIMATES AND DISCLOSURE STATEMENT
- ATTACHMENT 8 - A – SITE HYDROGEOLOGIC CHARACTERIZATION REPORT  
- B – BORING LOGS AND BORING MAP
- ATTACHMENT 9 - SETTLEMENT CALCULATIONS
- ATTACHMENT 10 - STORM DRAINAGE REPORT
- ATTACHMENT 11 - FIRE DEPARTMENT LETTER
- ATTACHMENT 12 - A - APPENDIX I – ACCEPTABLE WASTE FOR CLASS TWO LANDFILLS  
- B - APPENDIX II – UNACCEPTABLE WASTE FOR CLASS TWO LANDFILLS
- ATTACHMENT 13 - GROUNDWATER MONITORING PLAN

## 1.0 INTRODUCTION

Project Title: Permit Application for the Greenpointe Class Two Construction, Demolition and Land-Clearing Debris (C&D) Landfill Expansion

Owner: Wasteco, Inc.  
Post Office Box 8028  
Greenville, South Carolina 29604

Owners Representative: Mr. Radford Jenkins,

Consulting Engineer: Alliance Consulting Engineers, Inc.  
124 Verdae Boulevard.  
Bonaventure II, Suite 505  
Greenville, South Carolina 29607

Reps: Kyle M. Clampitt, PE, Vice President  
Gregory T. Farrell, PE, Senior Project Manager  
Ryan T. Ohmer, PE, Project Engineer  
Emily N. Palamara, Engineering Associate

The Greenpointe Landfill is located approximately one (1) mile north of Old Greenville Highway Extension (SC Highway 88) on Hamlin Road near the City of Easley, South Carolina (Exhibits A & B). Wasteco, Inc. currently operates a Class Two Construction and Demolition Debris (C&D) Landfill in the central portion of the property (Exhibit C). The nearest surface body of water is a Tributary to Pickens Creek, which is located approximately one-hundred and fifty (150) feet from the base of the C&D Landfill. Pickens Creek, flows southwesterly through the southern portion of the Wasteco, Inc. property, towards the Three and Twenty Creek. Wasteco, Inc. is proposing to expand the C&D Landfill by creating an additional cell, Cell Two, as well as expanding the existing Cell One (Exhibit D). The permitted waste stream for the facility will be 57,000 tons per year. The permitted waste stream is based on *R.61-107.17 Solid Waste Management: Demonstration-of-Need*, which states that each disposal facility will be allowed up to a maximum yearly disposal rate equal to the amount of solid waste destined for disposal within the planning area of the facility.

# GREENPOINTE CLASS TWO CONSTRUCTION AND DEMOLITION DEBRIS LANDFILL EXPANSION IN ANDERSON COUNTY, SOUTH CAROLINA SITE LOCATION MAP

Wasteco, Inc.

+/- 212 Acres



GRAPHIC SCALE (IN MILES)  
JANUARY 18, 2018

**ALLIANCE**  
CONSULTING ENGINEERS  
PREPARED BY:  
ALLIANCE CONSULTING ENGINEERS, INC.  
INFORMATION FROM:  
GDOT HIGHWAY MAP  
ANDERSON COUNTY, SOUTH CAROLINA  
DATED 2005

**EXHIBIT A**

**SITE**

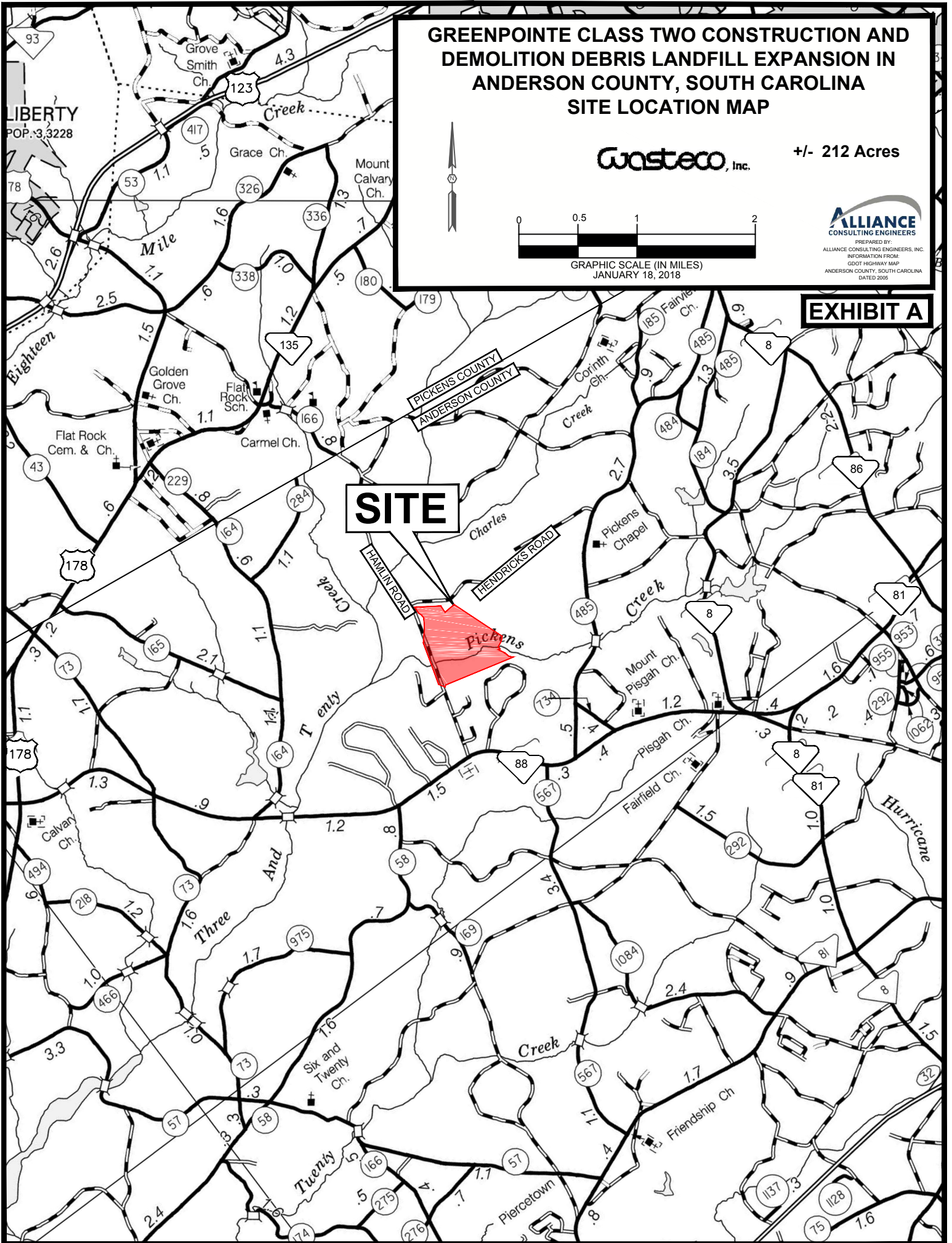



**GREENPOINTE CLASS TWO CONSTRUCTION AND  
DEMOLITION DEBRIS LANDFILL EXPANSION IN  
ANDERSON COUNTY, SOUTH CAROLINA  
AERIAL MAP**

PICKENS COUNTY  
ANDERSON COUNTY

**Wasteco, Inc.**

**+/- 212 Acres**

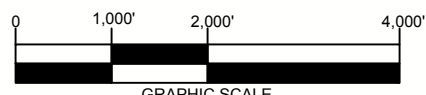

GRAPHIC SCALE  
JANUARY 18, 2018

PREPARED BY:  
ALLIANCE CONSULTING ENGINEERS, INC.  
INFORMATION FROM:  
USDA NRCS GEOSPATIAL DATA GATEWAY  
ANDERSON COUNTY, SOUTH CAROLINA  
DATED: 2011

**EXHIBIT B**

**SITE**

HENDRICKS ROAD

HANN ROAD

88



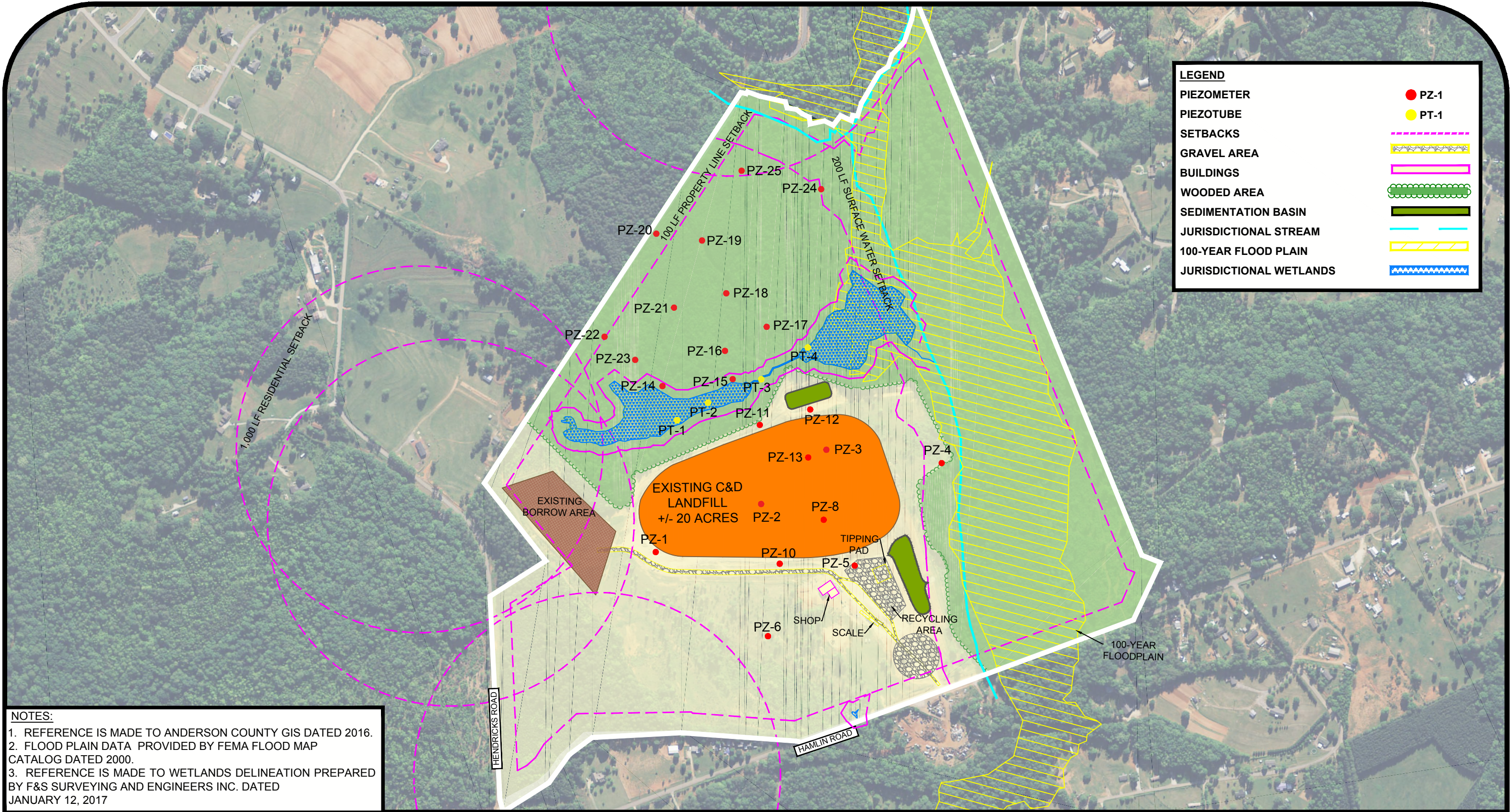

LEGEND	
PIEZOMETER	● PZ-1
PIEZOTUBE	● PT-1
SETBACKS	--- (dashed lines)
GRAVEL AREA	▨ (hatched pattern)
BUILDINGS	▭ (solid rectangle)
WOODED AREA	⊙ (circled pattern)
SEDIMENTATION BASIN	▬ (solid bar)
JURISDICTIONAL STREAM	— (solid line)
100-YEAR FLOOD PLAIN	▨ (hatched pattern)
JURISDICTIONAL WETLANDS	▨ (hatched pattern)

**NOTES:**  
 1. REFERENCE IS MADE TO ANDERSON COUNTY GIS DATED 2016.  
 2. FLOOD PLAIN DATA PROVIDED BY FEMA FLOOD MAP CATALOG DATED 2000.  
 3. REFERENCE IS MADE TO WETLANDS DELINEATION PREPARED BY F&S SURVEYING AND ENGINEERS INC. DATED JANUARY 12, 2017

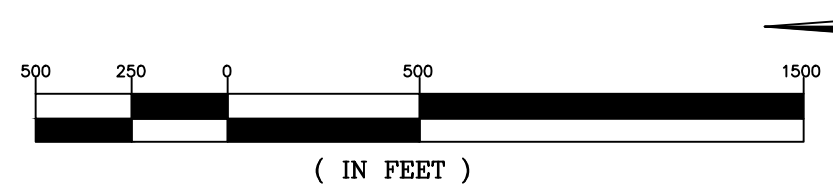

## Existing Conditions Map of the +/- 212-Acre Greenpointe C&D Landfill in Anderson County, South Carolina

**Wasteco, Inc.**

**ALLIANCE**  
 CONSULTING ENGINEERS  
 Prepared by Alliance Consulting Engineers, Inc.

**EXHIBIT C**

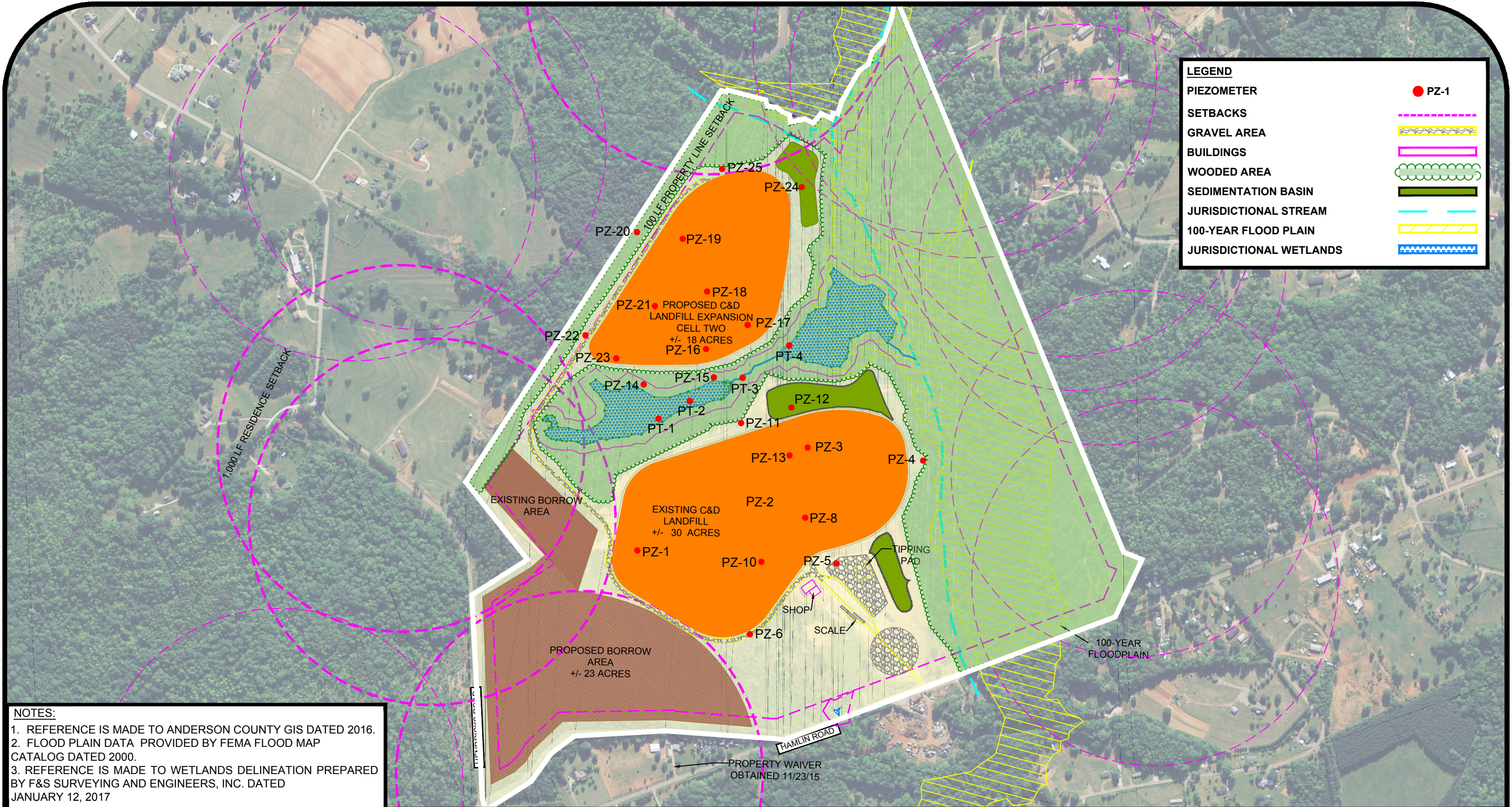

LEGEND	
PIEZOMETER	● PZ-1
SETBACKS	--- (dashed pink line)
GRAVEL AREA	▨ (yellow hatched pattern)
BUILDINGS	▭ (pink outline)
WOODED AREA	⊞ (green wavy pattern)
SEDIMENTATION BASIN	▬ (solid green area)
JURISDICTIONAL STREAM	— (solid cyan line)
100-YEAR FLOOD PLAIN	▨ (yellow hatched pattern)
JURISDICTIONAL WETLANDS	▨ (blue wavy pattern)

**NOTES:**  
 1. REFERENCE IS MADE TO ANDERSON COUNTY GIS DATED 2016.  
 2. FLOOD PLAIN DATA PROVIDED BY FEMA FLOOD MAP CATALOG DATED 2000.  
 3. REFERENCE IS MADE TO WETLANDS DELINEATION PREPARED BY F&S SURVEYING AND ENGINEERS, INC. DATED JANUARY 12, 2017

**EXHIBIT D**

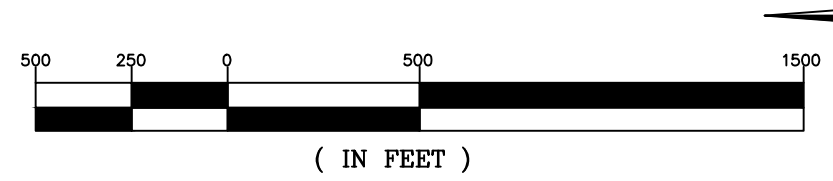

## Proposed Site Plan of the Greenpointe Class Two C&D Landfill in Anderson County, South Carolina

**Wasteco, Inc.**

**ALLIANCE**  
CONSULTING ENGINEERS  
Prepared by Alliance Consulting Engineers, Inc.

Project No.: 16227-0004  
March 2018

Access to the Greenpointe Landfill is provided by Hamlin Road, which is currently the one (1) roadway providing access to the landfill property. Hamlin Road is a two (2)-lane paved road with eleven (11)-foot wide lanes lined with an unpaved shoulder. Hamlin Road intersects Old Greenville Highway Extension (SC Highway 88) approximately 1.5 miles to the north of the landfill property. Interstate 85 (I-85) is approximately eight (8) miles northeast from the property.

### **1.1 Topography**

The Greenpointe Landfill property appears to consist of mild to moderately steep slopes, sloping towards the center of the property as illustrated in the Topographic Map (Exhibit E). Additionally, a Topographic Survey was completed by F&S Surveyors Engineers & Planners, Inc. (F&S) dated December 2016 (Attachment 1). Elevations range from 892 feet above Mean Sea Level (MSL) near the northern portion of the property to approximately 790 feet above MSL near the southern portion of the property, within Pickens Creek. The existing topography of the proposed C&D Landfill Cell One and Cell Two are illustrated in the Existing Conditions and Demolition Plan (DWG No. 01,1168-D21 Sheet C-1.0) dated December 2018, consist of mild to moderate slopes with an elevation range of 800 feet to slightly greater than 872 feet.

### **1.2 Floodplains**

The Federal Emergency Management Agency (FEMA) Flood Map (Exhibit F) dated January 18, 2018, derived from FEMA Flood Map Catalog Panel Numbers 45007C0040E, 45007C0110E, 45007C0130F, 45077C295D, 45077C0315D, 45077C0410D, dated 2011, shows areas that are within the 100-year flood zone. The majority of the Greenpointe Landfill property appears to be located within Zone X, which denotes areas of minimal flooding; however, there is a portion in the center of the site within Zone AE, which denotes areas within the 100-year flood plain. The proposed C&D Landfill area will not be located within a 100-year flood plain.

**GREENPOINTE CLASS TWO CONSTRUCTION AND  
DEMOLITION DEBRIS LANDFILL EXPANSION IN  
ANDERSON COUNTY, SOUTH CAROLINA  
TOPOGRAPHIC MAP**

**Wasteco, Inc.**

**+/- 212 Acres**

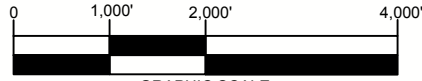

GRAPHIC SCALE  
CONTOUR INTERVAL : 10 FEET  
JANUARY 18, 2018



PREPARED BY:  
ALLIANCE CONSULTING ENGINEERS, INC.  
INFORMATION FROM:  
ANDERSON COUNTY, SOUTH CAROLINA  
USGS DATA  
DATED 2017

**EXHIBIT E**

**SITE**

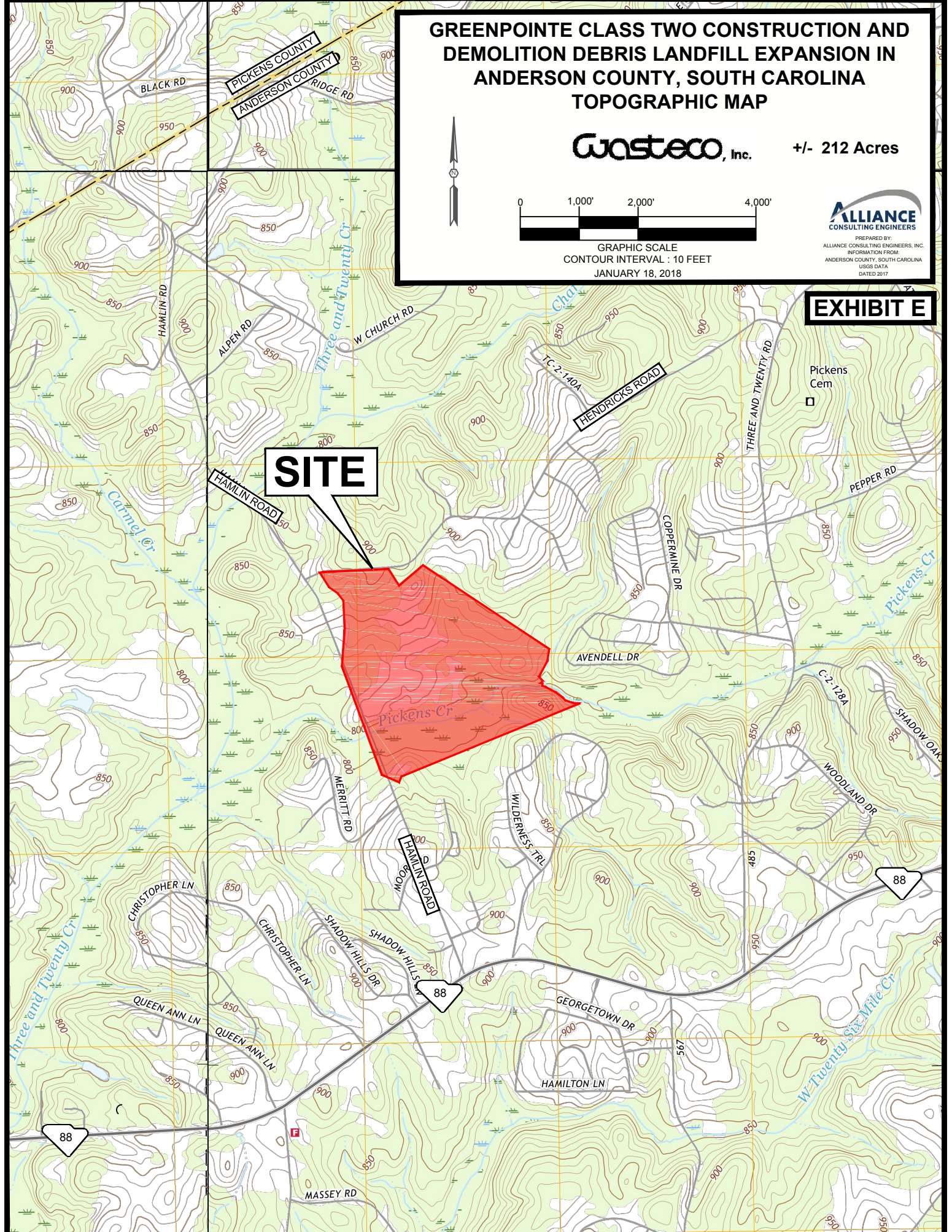
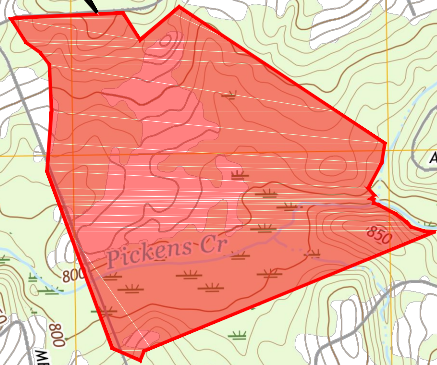

# GREENPOINTE CLASS TWO CONSTRUCTION AND DEMOLITION DEBRIS LANDFILL EXPANSION IN ANDERSON COUNTY, SOUTH CAROLINA FEMA FLOOD MAP

**Wasteco, Inc.**

**+/- 212 Acres**

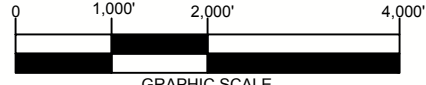

GRAPHIC SCALE  
JANUARY 18, 2018

**ALLIANCE**  
CONSULTING ENGINEERS  
PREPARED BY:  
ALLIANCE CONSULTING ENGINEERS, INC.  
INFORMATION FROM:  
FEMA FLOOD MAP CATALOG  
PANEL NO. 4507C0404E, 4507C0110E,  
4507C0130E, 4507C0290D, 4507C0315D,  
4507C0410D  
DATED 2011



**EXHIBIT F**

**SITE**

ZONE X

Anderson County  
Unincorporated Areas  
450013

LEGEND

-  ZONE A/AE - Areas of 100-Year Flood
-  ZONE X - Areas of Minimal Flooding

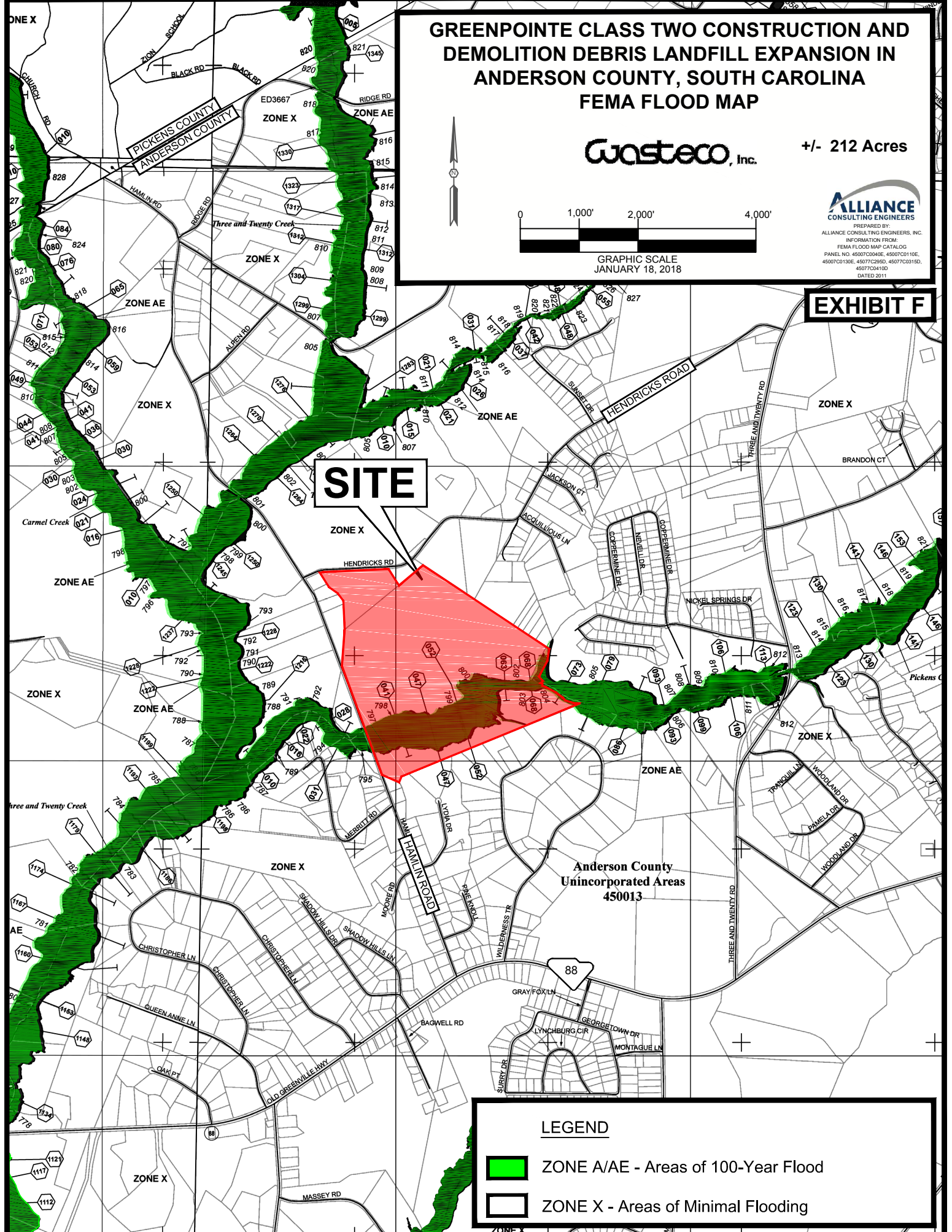

### 1.3 Wetlands

The Wetlands Delineation prepared by Froehling & Robertson, Inc. (F&R) (Attachment 2) indicates that there are approximately 6.97 acres of Jurisdictional Wetlands and 4,734.7 linear feet (LF) of Waters of the United States. A request for Jurisdictional Determination was submitted to the U.S. Army Corps of Engineers (USACE) on January 24, 2017, by F&R. A letter of Jurisdictional Determination from the USACE dated March 13, 2018 confirmed the delineated wetlands. The National Wetlands Inventory (NWI) Map (Exhibit G) also indicates the presence of potential wetlands within the landfill property. The proposed landfill expansion area is not located within the areas of jurisdictional wetlands.

**GREENPOINTE CLASS TWO CONSTRUCTION AND DEMOLITION DEBRIS LANDFILL EXPANSION IN ANDERSON COUNTY, SOUTH CAROLINA  
NATIONAL WETLAND INVENTORY (NWI) MAP**

**Wasteco, Inc.**

**+/- 212 Acres**

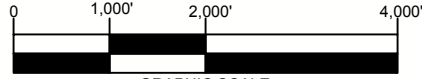

GRAPHIC SCALE  
JANUARY 18, 2018



PREPARED BY:  
ALLIANCE CONSULTING ENGINEERS, INC.  
INFORMATION FROM:  
WETLAND ONLINE MAPPER  
CREDIT: US FISH AND WILDLIFE SERVICE

**EXHIBIT G**

**SITE**

WETLANDS LEGEND	
	Freshwater Emergent
	Freshwater Forested/Shrub
	Estuarine and Marine Deepwater
	Estuarine and Marine
	Freshwater Pond
	Lake
	Riverine
	Other

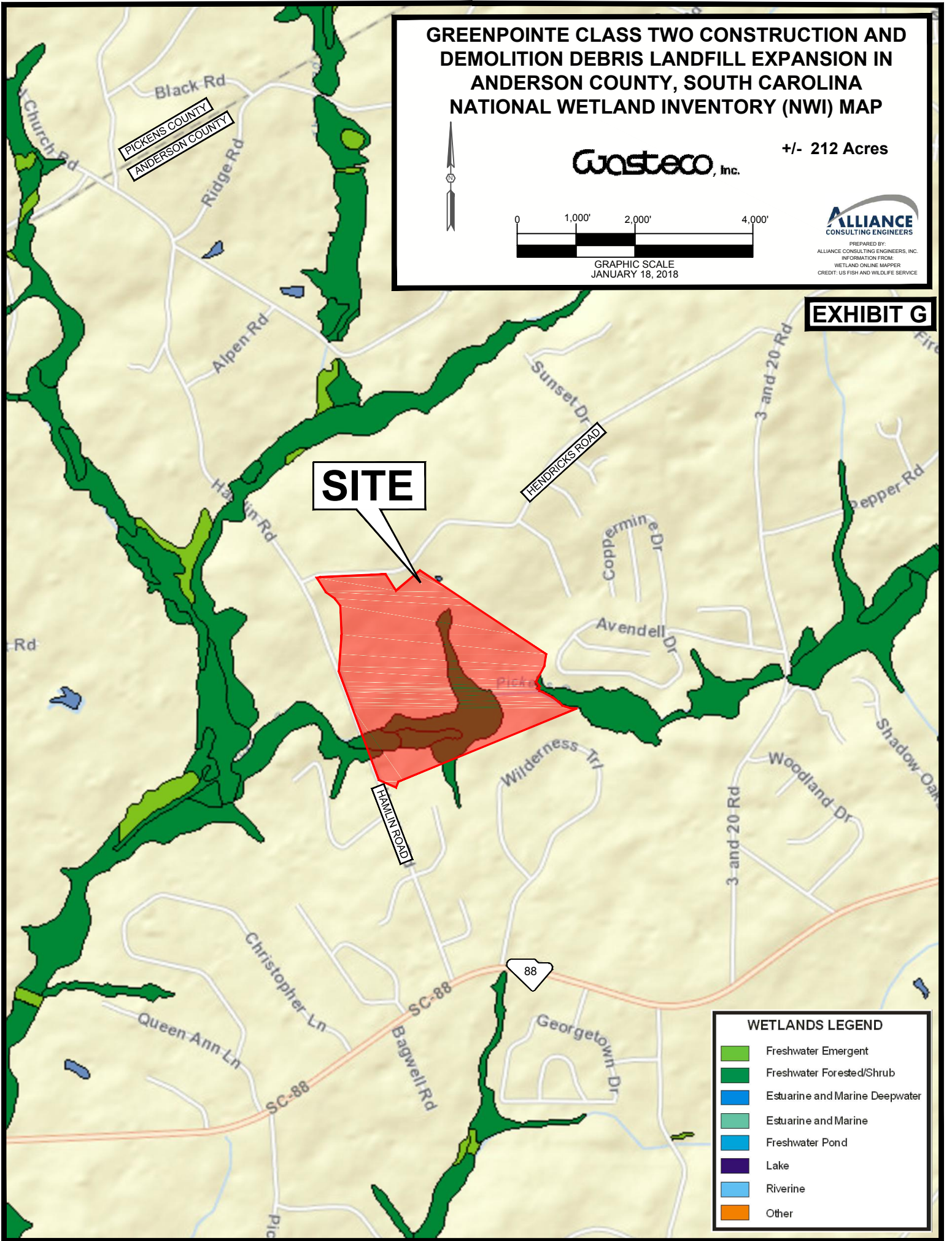



## 2.0 PERMIT APPLICATION REQUIREMENTS

### 2.1 Demonstration of Need

A letter from the South Carolina Department of Health and Environmental Control (SCDHEC) dated January 18, 2018 acknowledging Demonstration of Need is included as Attachment 3. Based on a waste stream of 29,000 tons per year, the design capacity for Cell One and Cell Two are approximately 1.44 million cubic yards, and 625,166 cubic yards, respectively. The Proposed C&D landfill will have a footprint that is approximately thirty (30) acres and eighteen (18) acres for Cell One and Cell Two, and will have an operation life ranging from approximately thirty (30) to sixty-two (62) years and thirteen (13) to twenty-seven (27) years. The life expectancy of the landfill is dependent upon the type of materials accepted, the compaction ratio of the material accepted, and the annual waste stream accepted at the landfill. The volume and life expectancy calculations are included in Attachment 4. Open dumping of construction, demolition and land-clearing debris in areas not permitted for disposal will not be allowed. Wasteco, Inc. will notify the Department prior to any transfer of ownership or operation of the landfill during the active life of the landfill.

### 2.2 Consistency Determination

A Letter of Consistency dated August 15, 2017, documenting that the proposed C&D Landfill Expansion is consistent with Anderson County's Solid Waste Management Plan, local zoning and land-use plans, and buffer requirements is included as Attachment 5. The proposed C&D Landfill Expansion will serve Anderson County, which is within the Appalachian region of South Carolina, and will accept only those items listed in Appendix I of Solid Waste Regulation *R.61-107.19*.

#### a) Anderson County Solid Waste Management Plan

The siting and design of the proposed C&D Landfill Expansion is pursuant to the Anderson County Solid Waste Management Plan dated December 7, 2004, which is included in Attachment 5. The expansion of the

Class Two C&D Landfill at the Greenpointe Landfill was first reviewed as to its ability to meet regulations in the Anderson County Zoning Ordinance. The Determination of Consistency was submitted to SCDHEC and was confirmed to be consistent with the Anderson County Solid Waste Management Plan.

**b) Zoning and Ordinances**

Currently, the two parcels that incorporate the Greenpointe Landfill are zoned Services District (S-1) and Residential Agricultural (R-A) by Anderson County, as illustrated in the Zoning Map in Exhibit H and Attachment 5. *Anderson County, SC Code of Ordinances Section 5:19. – S-1, Services District* states; “The district is established to provide a transition between commercial and industrial districts by allowing commercial uses, service related uses, and light industries”. *Anderson County, SC Code of Ordinances Section 5:2. – R-A, Residential Agricultural* states; “The purpose of this district is to provide spacious development and prevent untimely scattering of dense urban uses.” The expansion of Cell Two will be confined to the portion of the landfill property that is designated S-1. The street classification for Hamlin Road is L (Local). The property is subject to a 40-foot power line easement; Hendricks Road right-of-way, Hamlin Road right-of-way, and an underground telephone right-of-way.

The eastern boundary of the Landfill property is adjacent to land classified as R-20 – Single Family Residential District, and is single-family residential development. The western, northern, and southern boundary of the Landfill is classified as R-A – Residential Agriculture. Pickens Creek is adjacent to the southern property boundary, Hamlin Road is adjacent to the western property boundary, and Hendricks Road is on the northern property boundary. The northeastern boundary is bordered by residential development.

# GREENPOINTE CLASS TWO CONSTRUCTION AND DEMOLITION DEBRIS LANDFILL EXPANSION IN ANDERSON COUNTY, SOUTH CAROLINA ZONING MAP

**Wasteco, Inc.**

+/- 212 Acres



GRAPHIC SCALE  
JANUARY 18, 2018



PREPARED BY:  
ALLIANCE CONSULTING ENGINEERS, INC.  
INFORMATION FROM:  
USDA NRCS GEOSPATIAL DATA GATEWAY  
ANDERSON COUNTY, SOUTH CAROLINA  
DATED 2011

**EXHIBIT H**

**SITE**

## LEGEND

- R-A
- R-40
- R-20
- R-15
- R-12
- R-10
- R-8
- R-D
- R-M1
- R-M2
- R-M7
- R-M
- R-MA
- R-MHP
- O-D
- POD
- C-1N
- C-1R
- C-1
- C-2
- C-3
- S-1
- I-1
- I-2
- PD
- AP
- RRD

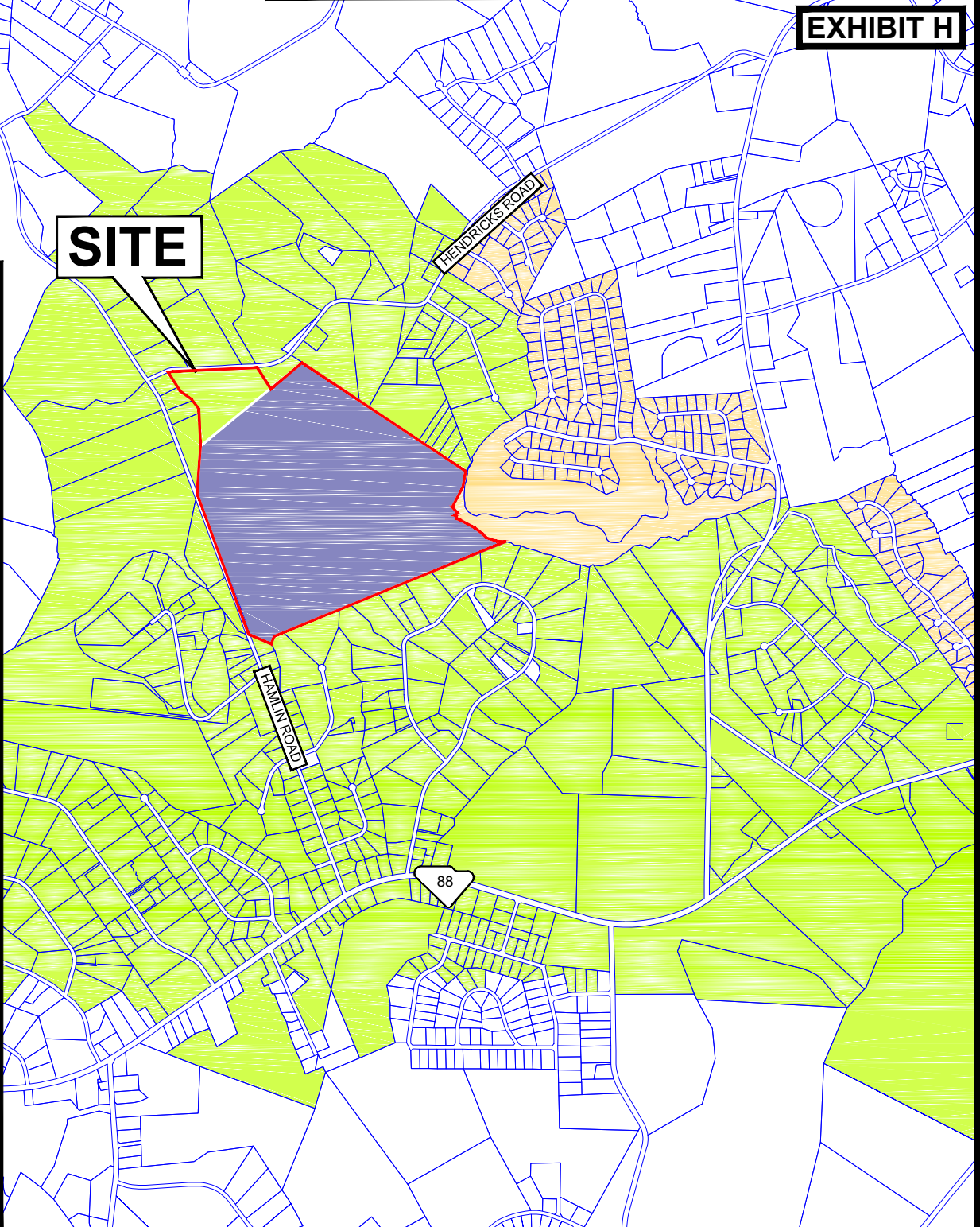

**c) Buffer Requirements**

The proposed C&D Landfill expansion boundary of the fill area will be located in accordance with *R.61-107.19 Part IV, Section B. Location Restrictions*, and therefore; will not be located:

1. Within 1,000 feet of any residence, school, day-care center, church, hospital, or publically owned recreational park area;
2. Within one-hundred (100) feet of any property line;
3. Within two-hundred (200) feet of any surface water that holds visible water for greater than six (6) consecutive months, excluding drainage ditches, sedimentation ponds, and other operational features on the site;
4. Within one-hundred (100) feet of any drinking water well; and
5. Within any property rights-of-way or fifty (50) feet of underground or aboveground utility equipment or structures, i.e., water lines, sewer lines, storm drain, telephone lines, electric lines, natural gas lines, etc. without the approval of the impacted utility.

**2.3 Permit Application**

Prior to construction and operation of the landfill, a Permit to construct the landfill will be obtained from SCDHEC. A copy of the completed SCDHEC “Application for Permit to Construct a Solid Waste Management System” is included in Attachment 6.

**2.4 Financial Assurance and Disclosure Statement**

In accordance with requirements indexed in *R.61-107.19 Part 1, Section E 1-2*, Wasteco, Inc. must provide a detailed estimate of the necessary funds for the Closure, Post-Closure Care, and potential Corrective Action Costs of the proposed landfill. A copy of the financial assurance Estimate is enclosed in Attachment 7. In addition to the Financial Assurance Cost Estimates for the Closure and Post-Closure of the Landfill, a Disclosure Statement was prepared pursuant to *Part I, Section F.1 of R.61-107.19*, and is enclosed in Attachment 7.

## 2.5 Construction Plans

Greenpointe Class Two C&D Landfill Expansion Plans (DWG No. 01, 1168-D21 dated December 2018) have been prepared by a South Carolina Licensed Professional Engineer. The plans are considered part of the Permit Application. The plans include a Site Plan (Sheet C-3.0) on a scale of not greater than two-hundred (200) feet per inch. The Site Plan indicates the approximate property boundaries, proposed footprint of the C&D Landfill, existing and proposed stormwater detention basins, access roads, and perimeter fencing and gates. In addition, the locations of stormwater/sediment basins and stormwater ditches are illustrated on the Site Plan. A Proposed Site Plan (Exhibit D) has been prepared that illustrates the various on-site improvements and land uses. In addition, the Construction Plans (DWG No. 01, 1168-D21) illustrate the proposed C&D debris placement area, closure contours of the landfill, typical cross-sections, drainage controls, and all pertinent information to clearly indicate the orderly development, operation, and completion of the facility.

## 2.6 Contiguous Properties

The Greenpointe Landfill property, which consists of Tax Map Numbers (TMS#) 138-00-04-013 and TMS# 164-00-02-036, as illustrated in the Tax Map in Exhibit I, was previously undeveloped woodlands. The present land use is that of an active C&D Landfill and collection and recycling facilities. Twenty-nine (29) properties are located adjacent to the property, and information for the contiguous landowners can be found in the Adjoining Properties Table in Attachment 3.

## 2.7 Tonnage Limit

As a part of the Demonstration of Need Process (Attachment 3), SCDHEC determined the maximum annual tonnage limit. Based on the facility's design capacity of approximately 1.44 million cubic yards in Cell One and 625,166 cubic yards in Cell Two, and an expected operation life ranging from approximately thirty (30) to sixty-two (62) years in Cell One and thirteen (13) to twenty-seven (27) years in Cell Two. The proposed Class Two C&D Landfill Cell Two will have a maximum annual tonnage limit of 57,000 tons per year.

**GREENPOINTE CLASS TWO CONSTRUCTION AND  
DEMOLITION DEBRIS LANDFILL EXPANSION IN  
ANDERSON COUNTY, SOUTH CAROLINA  
TAX MAP**

**Wasteco, Inc.**

**+/- 212 Acres**

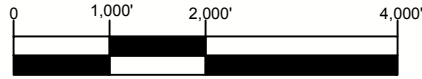

GRAPHIC SCALE  
JANUARY 18, 2018



PREPARED BY:  
ALLIANCE CONSULTING ENGINEERS, INC.  
INFORMATION FROM:  
USDA NRCS GEOSPATIAL DATA GATEWAY  
ANDERSON COUNTY, SOUTH CAROLINA  
DATED: 2011

**EXHIBIT I**

**SITE**

**PARCEL 2**

**PARCEL 1**

HENDRICKS ROAD

HANNON ROAD

88

**LEGEND**

**PARCEL 1 - TMS # 164-00-02-036**

**PARCEL 2 - TMS # 138-00-04-013**

**2.8 Coastal Zone Management**

The proposed site of the landfill cell is not located in a coastal zone; therefore, the site is not subject to the South Carolina Coastal Zone Management Plan.

### **3.0 LANDFILL COVER AND STABILIZATION PLAN**

#### **3.1 Source of Cover Material**

The on-site soil is mainly alluvial sediments or residual soils derived from in-place weathering of the bedrock in the region. Shallow, residual soil consisted of slightly micaceous sandy-silts, silty-sand, clayey-sand, and high plasticity silts or clays. Coarser-grained, less plastic, micaceous sandy-silt, sandy-silty-clay, and silty-sand extended to the borehole termination depth. Transitional zones of partially weathered rock were encountered. Soils will be stockpiled in a location convenient to the working face of the landfill. Additional cover soil will be borrowed from the Proposed Stockpile Area. The approximate location of this borrow area is identified in the Site Plan DWG No. 01, 1168-D21 Sheet C-3.0) dated December 2018.

#### **3.2 Frequency of Cover**

The C&D debris will be covered with a minimum of six (6) inches of compacted on-site soils at least once every thirty (30) days. If conditions warrant, the debris will be covered more frequently.

#### **3.3 Depth of Disposal Area**

The cell floor of the proposed landfill area will be a minimum of two (2) feet above the seasonal high groundwater table. Based on monitoring well data and boring logs for the site (Attachment 8A), the groundwater elevations across the site range from a minimum elevation of 795.86 feet above mean sea level (PZ 4) to 839.39 feet above mean sea level (PZ 20) (Table 1). The base grade for the proposed C&D landfill Cell 1 ranges from approximately 803 feet to 837 feet above mean sea level. The base grade for the proposed Cell 2 ranges from approximately 803 feet to 839 feet above sea level, as illustrated on the Base Elevation Grading and Storm Drainage Plan (DWG No. 01, 1168-D21 Sheets C-4.0 and C-4.1 dated December 2018). Boring logs for the subject area, and the Boring Log Map are included as Attachment 8A and 8B, which indicate that the soil conditions at the



proposed C&D landfill area are not indicative of soils that result in excessive settlement.

Base grade settlement calculations were performed on the proposed C&D Landfill utilizing the existing grade, proposed grade and closure plans (Attachment 9). Bunnel-Lammons Engineering, Inc. (BLE) installed twelve Piezometers (PZ 14 – PZ 25) across the proposed landfill expansion areas and groundwater elevation was gathered for twelve (12) months. Settlement calculations were performed for each expansion area. The maximum total subgrade settlement from the waste loading due to the expansion is estimated to be approximately 17.2 inches. The maximum settlement was found at the point of maximum waste and structural fill fitness, near boring B-3. Settlement near the perimeter of the waste placement are expected to be approximately 0.2 feet or less.

**TABLE 3**  
**GROUNDWATER DEPTH AND ELEVATION DATA**  
 Greenpointe Class 2 Landfill Expansion  
 Anderson County, South Carolina  
 BLE Project Number J18-11684-02

Piezometer/ Piezotube	Ground Elevation	TOC Elevation	Groundwater Elevation Data																				Maximum Elevation	Minimum Elevation	Head Difference																	
			3/9/10	8/19/10	3/21/11	8/11/11	3/16/12	9/11/12	3/4/13	9/10/13	2/26/14	8/19/14	3/5/15	9/9/15	3/15/16	8/30/16	3/9/17	9/5/17	1/24/18	2/22/18	3/14/18	5/1/18				6/13/18	6/29/18	7/31/18	8/31/18	9/19/18	10/30/18	11/26/18	1/3/19									
PZ-1	854.49	857.20	830.04	828.23	827.34	826.79	827.37	826.61	827.10	830.05	830.57	829.93	830.85	830.10	<b>832.77</b>	831.45	830.55	830.28	829.87	830.56	830.78	830.95	831.15	830.99	830.59	830.41	830.02	829.56	830.44	831.59	832.77	826.61	6.16									
PZ-2															Abandoned																											
PZ-4	801.48	804.60	NM	NM	NM	NM	NM	NM	NM	NM	NM	NM	NM	NM	NM	NM	NM	NM	797.45	798.03	798.30	798.00	797.45	797.32	796.45	796.21	795.86	796.13	798.32	<b>800.51</b>	800.51	795.86	4.65									
PZ-5	824.88	828.20	NM	NM	NM	NM	NM	NM	NM	NM	NM	NM	NM	NM	NM	800.03	804.76	799.45	Dry	Dry	800.53	802.20	802.95	803.67	803.23	802.36	802.22	801.45	800.58	802.81	<b>806.68</b>	806.68	799.45	7.23								
PZ-6	819.61	822.90	NM	NM	NM	NM	NM	NM	NM	NM	NM	NM	NM	NM	NM	NM	NM	NM	818.20	818.10	818.53	817.68	816.04	815.31	813.64	813.45	812.19	813.61	818.88	<b>819.19</b>	819.19	812.19	7.00									
PZ-8	813.31	816.30	NM	NM	NM	NM	NM	NM	NM	NM	NM	NM	NM	NM	NM	798.88	803.49	799.54	800.01	799.52	800.82	803.23	803.74	803.25	803.00	802.34	800.76	800.23	799.99	799.06	<b>809.32</b>	809.32	798.88	10.44								
PZ-9																Abandoned																										
PZ-10	822.29	824.80	815.92	809.44	814.45	808.84	815.32	812.42	816.09	815.58	816.63	812.35	817.03	811.80	816.29	811.20	814.09	811.86	814.50	816.13	816.23	816.00	815.33	814.59	813.52	813.48	812.69	812.68	816.08	<b>817.78</b>	817.78	808.84	8.94									
PZ-11	812.11	814.90	NM	NM	NM	NM	NM	NM	NM	NM	NM	NM	NM	NM	807.57	809.19	807.61	808.64	809.20	809.39	809.46	809.57	809.07	808.92	807.97	807.73	808.06	808.12	809.56	<b>810.30</b>	810.30	807.52	2.78									
PZ-12	806.82	810.00	NM	NM	NM	NM	NM	NM	NM	NM	NM	NM	NM	NM	NM	NM	NM	NM	797.94	800.84	798.15	799.71	798.01	800.37	801.24	801.33	801.05	800.47	800.15	798.99	798.59	798.38	798.77	801.23	<b>803.08</b>	803.08	797.94	5.14				
PZ-13	811.82	815.10	NM	NM	NM	NM	NM	NM	NM	NM	NM	NM	NM	NM	798.39	801.66	798.19	799.60	798.45	800.09	801.91	802.14	801.82	801.62	800.77	799.72	799.39	798.68	798.73	801.41	<b>805.30</b>	805.30	798.19	7.11								
PZ-14	822.99	826.25	NP	NP	NP	NP	NP	NP	NP	NP	NP	NP	NP	NP	NP	NP	NP	NP	822.18	822.35	822.42	822.20	821.78	821.92	821.15	820.92	821.51	821.59	822.54	<b>822.87</b>	822.87	820.92	1.95									
PZ-15	813.03	816.27	NP	NP	NP	NP	NP	NP	NP	NP	NP	NP	NP	NP	NP	NP	NP	NP	811.33	811.62	811.57	811.35	810.62	812.78	810.53	809.68	809.53	809.69	810.11	811.59	<b>812.38</b>	812.38	809.53	2.85								
PZ-16	816.24	819.63	NP	NP	NP	NP	NP	NP	NP	NP	NP	NP	NP	NP	NP	NP	NP	NP	815.19	815.49	815.82	815.61	814.03	813.81	812.15	811.84	811.48	812.84	815.52	<b>815.83</b>	815.83	811.48	4.35									
PZ-17	809.76	811.68	NP	NP	NP	NP	NP	NP	NP	NP	NP	NP	NP	NP	NP	NP	NP	NP	802.29	803.04	803.48	803.48	802.49	801.78	800.56	800.12	799.36	799.81	803.08	<b>804.17</b>	804.17	799.36	4.81									
PZ-18	824.02	827.72	NP	NP	NP	NP	NP	NP	NP	NP	NP	NP	NP	NP	NP	NP	NP	NP	817.89	821.04	821.66	821.17	816.50	815.18	814.11	813.82	813.47	813.83	820.84	<b>822.70</b>	822.70	813.47	9.23									
PZ-19	837.05	840.74	NP	NP	NP	NP	NP	NP	NP	NP	NP	NP	NP	NP	NP	NP	NP	NP	822.58	825.32	826.10	826.10	824.78	823.45	821.95	821.35	820.73	819.65	823.51	<b>827.98</b>	827.98	819.65	8.33									
PZ-20	847.19	850.06	NP	NP	NP	NP	NP	NP	NP	NP	NP	NP	NP	NP	NP	NP	NP	NP	829.95	833.55	834.86	835.66	834.92	833.52	831.29	830.26	828.93	827.70	832.53	<b>839.39</b>	839.39	827.70	11.69									
PZ-21	833.02	835.09	NP	NP	NP	NP	NP	NP	NP	NP	NP	NP	NP	NP	NP	NP	NP	NP	827.67	829.11	829.45	829.58	828.46	827.28	825.31	824.62	823.08	823.32	828.19	<b>836.45</b>	836.45	823.08	7.37									
PZ-22	846.99	850.09	NP	NP	NP	NP	NP	NP	NP	NP	NP	NP	NP	NP	NP	NP	NP	NP	833.41	834.15	834.55	834.57	834.35	834.03	833.59	833.35	833.01	832.99	834.15	<b>835.95</b>	835.95	832.99	2.96									
PZ-23	834.58	837.68	NP	NP	NP	NP	NP	NP	NP	NP	NP	NP	NP	NP	NP	NP	NP	NP	828.68	829.72	829.67	829.58	828.86	828.48	828.01	827.91	827.79	828.03	829.75	<b>831.53</b>	831.53	827.79	3.74									
PZ-24	821.40	824.65	NP	NP	NP	NP	NP	NP	NP	NP	NP	NP	NP	NP	NP	NP	NP	NP	NP	NP	NP	NP	Dry	Dry	Dry	Dry	Dry	Dry	Dry	Dry	Dry	Dry	Dry	Dry	Dry							
PZ-25	819.71	822.88	NP	NP	NP	NP	NP	NP	NP	NP	NP	NP	NP	NP	NP	NP	NP	NP	NP	NP	NP	NP	NP	NP	NP	NP	NP	NP	NP	NP	NP	NP	NP	NP	NP	NP						
PT-1	816.50	819.89	NP	NP	NP	NP	NP	NP	NP	NP	NP	NP	NP	NP	NP	NP	NP	NP	817.12	817.10	817.12	817.02	816.88	817.23	816.75	816.90	816.88	817.17	816.90	816.88	817.17	<b>817.37</b>	817.37	816.75	0.62							
PT-2	813.11	814.99	NP	NP	NP	NP	NP	NP	NP	NP	NP	NP	NP	NP	NP	NP	NP	NP	813.65	813.52	813.63	813.57	813.51	<b>814.14</b>	813.53	813.41	813.46	813.53	813.60	813.79	813.79	814.14	813.41	0.73								
PT-3	805.62	808.01	NP	NP	NP	NP	NP	NP	NP	NP	NP	NP	NP	NP	NP	NP	NP	NP	806.04	805.89	806.22	806.65	807.01	807.27	807.04	807.21	807.39	807.76	<b>807.89</b>	807.89	805.89	2.00										
PT-4	802.05	804.63	NP	NP	NP	NP	NP	NP	NP	NP	NP	NP	NP	NP	NP	NP	NP	NP	802.06	802.16	802.17	802.13	801.88	802.21	801.60	801.34	802.07	802.04	802.11	<b>802.26</b>	802.26	801.34	0.92									

Piezometer/ Piezotube	Ground Elevation	TOC Elevation	Depth to Water Below Ground Surface																																
			3/9/10	8/19/10	3/21/11	8/11/11	3/16/12	9/11/12	3/4/13	9/10/13	2/26/14	8/19/14	3/5/15	9/9/15	3/15/16	8/30/16	3/9/17	9/5/17	1/24/18	2/22/18	3/14/18	5/1/18	6/13/18	6/29/18	7/31/18	8/31/18	9/19/18	10/30/18	11/26/18	1/3/19					
PZ-1	854.49	857.20	24.45	26.26	27.15	27.70	27.12	27.88	27.39	24.44	23.92	24.56	23.64	24.39	21.72	23.04	23.94	24.21	24.62	23.93	23.71	23.54	23.34	23.50	23.90	24.08	24.47	24.93	24.05	22.90					
PZ-2																																			
PZ-4	801.48	804.60	NM	NM	NM	NM	NM	NM	NM	NM	NM	NM	NM	NM	NM	NM	NM	NM	4.03	3.45	3.18	3.48	4.03	4.16	5.03	5.27	5.62	5.35	3.16	0.97					
PZ-5	824.88	828.20	NM	NM	NM	NM	NM	NM	NM	NM	NM	NM	NM	NM	NM	NM	NM	NM	24.35	22.68	21.93	22.48	21.21	21.65	22.52	22.66	23.43	24.30	22.07	18.20					
PZ-6	819.61	822.90	NM	NM	NM	NM	NM	NM	NM	NM	NM	NM	NM	NM	NM	NM	NM	NM	1.41	1.51	1.08	1.93	3.57	4.30	5.97	6.16	7.42	6.00	0.73	0.42					
PZ-8	813.31	816.30	NM	NM	NM	NM	NM	NM	NM	NM	NM	NM	NM	NM	NM	NM	NM	NM	12.49	10.08	9.57	10.06	10.31	10.97	12.55	13.08	13.32	14.25	10.39	3.99					
PZ-9																																			
PZ-10	822.29	824.80	6.37	12.85	7.84	13.45	6.97	9.87	6.20	6.71	5.66	9.94	5.26	10.49	6.00	11.09	8.20	10.43	7.79	6.16	6.06	6.29	6.96	7.70	8.77	8.81	9.60	9.61	6.21	4.51					
PZ-11	812.11	814																																	

### 3.4 Final Contour

The contours illustrated on the Base Elevation Grading and Storm Drainage Plan represent the C&D landfill cell floor. The cell floor will have a minimum slope of 1% to promote positive stormwater drainage away from the C&D debris. The proposed C&D Landfill will have maximum side slopes of three (3) feet horizontal to one (1)-foot vertical.

### 3.5 Stabilization Plan

The Greenpointe Landfill takes all applicable measures to stabilize exposed areas and contain runoff to minimize on-site erosion and potential offsite discharge of sediment. The active Class Two C&D Landfill is constructed to be at a slope of no more than a 3:1 ratio to reduce erosion potential. Closed portions of the landfill will be seeded with native grasses or other suitable cover within fifteen (15) days of the completion of that portion of the landfill. The specific grasses to be planted and their corresponding planting dates can be found in Table 2 – Grassing Schedule. Vegetated swales convey the stormwater runoff to the Stormwater Basins on the central portion of the Landfill property. Check dams are maintained in the existing stormwater ditches to reduce erosion in the channels and to allow sediments and pollutants to settle. At discharge locations riprap was installed to reduce the velocity of the water and decrease erosion potential. Many surfaces at the Greenpointe Landfill remain pervious to allow for greater infiltration on the property. Unpaved roadways, vegetated open areas, and wooded areas allow for greater stormwater infiltration. On-site gravel roads have been constructed for all-weather use and are capable of withstanding the anticipated load limits for typical landfill equipment and vehicles.

The gravel roads will be maintained by landfill personnel on an as-needed basis utilizing a motor grader. Temporary stabilization, in the forms of seeding or mulching for stockpiles of landfill cover, inactive landfill portions, and unestablished final covers, is provided at the Greenpointe Landfill. Additionally, a visual inspection of active landfill sites will occur at least every seven (7) days by landfill personnel for areas of open landfill application, and every thirty (30) days for stabilized sites to ensure that sediment and erosion control measures are operating properly.

<b>TABLE 2 GRASSING SCHEDULE WASTECO, INC. GREENPOINTE CLASS TWO C&amp;D LANDFILL</b>	
<b>Schedule No. 1 - Planting Dates March 1st to August 14th</b>	
<b>Grass Type (Common Name)</b>	<b>(lbs. per acre)</b>
Common Bermuda (hulled)	20
Sericea Lespedeza (scarified)	50
Kentucky 31 fescue	60
<b>Schedule No. 2 - Planting Dates August 15th to February 28th</b>	
<b>Grass Type (Common Name)</b>	<b>(lbs. per acre)</b>
Rye Grain	20
Pensacola Bahia	30
Annual Ryegrass	5
Reseeding Crimson Clover	20
Sericea Lespedeza (unhulled, unscarified)	80
Kentucky 31 fescue	50
Common Bermuda (unhulled)	2

## 4.0 OPERATING PLAN

The proposed expansion will serve the entire county and will accept only those items listed in Appendix I of *R.61-107.19*, which have not come in contact with hazardous constituents, petroleum products, or lead based paint. The permitted waste stream for the facility will be 57,000 tons per year. The permitted waste stream is based on *R.61-107.17 Solid Waste Management: Demonstration-of-Need* which states that each disposal facility will be allowed up to a maximum yearly disposal rate equal to the amount of solid waste destined for disposal within the planning area of the facility. The current waste stream for the facility is approximately 29,000 tons per year. Open dumping of construction, demolition, and land-clearing debris is not permitted.

### 4.1 Landfill Capacity and Life Expectancy

Based on a proposed waste stream of approximately 29,000 tons per year, the design capacity for Cell One is approximately 1.44 million cubic yards and approximately 625,166 CY for Cell Two, over a waste disposal footprint of approximately thirty (30) acres for Cell One and eighteen (18) acres for Cell Two. The Proposed C&D landfill will have an operation life ranging from approximately thirty (30) to sixty-two (62) years and thirteen (13) to twenty-seven (27) years. The life expectancy of the landfill is dependent upon the type of materials accepted, the compaction ratio of the materials accepted, and the annual waste stream accepted at the landfill. The Operational Life Calculations are included in Attachment 4.

### 4.2 Waste Screening

#### a) Landfill Staffing and Sign Requirements

The Greenpointe C&D Landfill will have an attendant on duty at all times during operating hours. A sign will be posted at the landfill entrance that identifies the SCDHEC permit number, owner, operator, contact person, and emergency telephone number. In addition, the hours of operation and the types of waste allowed for disposal will be indicated on the sign. Following is a list of personnel responsible for the operation of the Greenpointe C&D Landfill:

<b>Solid Waste Management Department</b>	
Radford Jenkins	Radford@Wastecoinc.com
Administrative Office Phone	(864) 223-0100
Fax	(864) 442-6752
<b>Emergency Phone Numbers (After Hours)</b>	
Three and Twenty FD – Station 19	(864) 859-7926
Emergency	911

**b) Supervision and Training**

The Greenpointe C&D Landfill employs a Landfill Supervisor who is responsible for all day-to-day activities at the landfill. The scale house is staffed with employees who are trained and responsible for weighing incoming waste and inspecting it for unauthorized wastes. Each person employed at the landfill receives training in recognizing acceptable and unacceptable wastes. In addition, all equipment operators receive specific training regarding equipment operating procedures and maintenance procedures. The Landfill Supervisor will be responsible for training all employees. At least one (1) person who has received the appropriate operational training course and is a certified manager shall be on-site at all times. Training is conducted annually and prior to the beginning of work for all new employees. Training includes operational issues, record keeping and implementation of the contingency plan, at a minimum. Once a year, the entire Landfill Staff will review the landfill operation plan and contingency plan.

**c) Inspection and Measurement**

All C&D debris brought to the Landfill is weighed at the scale house and examined by the scale house operator. The incoming trucks are inspected at a minimum rate of one (1) out of every ten (10) trucks. The C&D debris will also be visually inspected at the working face of the Landfill as it is unloaded. Unloading will be limited to the working face of the Landfill.

**d) Unauthorized Waste Disposal**

Any material that is determined to be unacceptable will be removed from the Greenpointe C&D Landfill within 48 hours and properly disposed of by the responsible party. In the event that the responsible party is not known, the proper disposal of any unacceptable material will be the responsibility of Wasteco, Inc. Dependent on the nature of the unacceptable material, Wasteco, Inc. will dispose of the material at a permitted Subtitle D Landfill facility or retain the services of a hazardous waste disposal firm for proper disposal.

**e) Asbestos Disposal**

Prior to accepting any materials containing non-friable asbestos for disposal at the C&D Landfill, Wasteco, Inc. will require and include in its landfill records a copy of the “permission for disposal” from the generator. Wasteco, Inc. will retain these letters for a period of not less than five (5) years and will make them available to the SCDHEC upon request. Upon acceptance, any material containing non-friable asbestos should be covered immediately with a minimum of six (6) inches of clean soil, and the area where the material is buried should be identified and recorded.

**4.3 Control of Stormwater Drainage****a) Water Quality Protection**

The Greenpointe C&D Landfill will be maintained and operated in a manner that will protect the established water quality standards of the surface waters and groundwater. Stormwater and sediment control structures have been designed as part of the landfill to minimize the potential impact to on and off site surface waters. The calculation for the stormwater/sediment basins indicate a sediment trapping efficiency greater than 80% will be achieved. As required by the solid waste regulations, a minimum two (2) foot separation will be maintained between the C&D debris and the seasonal high groundwater table.

**b) Stormwater Control**

Three (3) permanent Stormwater Detention Basins are located at the Greenpointe Landfill. These basins are located southwest and southeast of the existing active Class Two C&D Landfill known as Cell One and southeast of the proposed Cell Two. All three (3) detention basins discharge into Pickens Creek from their outfalls.

The Greenpointe Landfill is currently covered under the General Permit for Stormwater Discharges Associated with Industrial Activity, permit number LF2-001. The stormwater control system was designed to accommodate the twenty-five (25)-year, twenty-four (24)-hour storm event for Anderson County. These basins are continuously maintained by Wasteco, Inc. to ensure proper functioning of the basins as a stormwater management device. The Stormwater drainage ditches have been designed to divert stormwater away from the C&D debris disposal areas and convey it to the detention basins. Best Management Practices (BMP), such as grassing, silt fencing, rip-rap, and stone check dams, are used to control stormwater runoff and sedimentation in existing storm drainage features, and will be utilized in proposed storm drainage features. The Base and Final Erosion and Sediment Control Plans (DWG No. 01,1168-D21 Sheet C-5.3 and C-5.4) dated December 2018 are included in the included as a part of the Construction Drawings submitted with the Expansion Permit Application.

**c) Stormwater Run-on/Run-off Control**

A stormwater run-on control system has been designed as part of the C&D Landfill to prevent flow onto the active portion of the landfill during peak discharges from a 25-year, 24-hour storm event for Anderson County. In addition, a stormwater run-off control system from the active portion of the landfill has been designed to collect and control the stormwater run-off resulting from the 25-year, 24-hour storm event for Anderson County. The Greenpointe C&D Landfill will utilize Best Management Practices (BMPs), such as grassing, silt fencing, stone check dams, and rip-rap in accordance



with the South Carolina Stormwater Management and Sediment Control Handbook for Land Disturbance Activities dated 2012. Greenpointe C&D Landfill personnel will conduct visual inspections of stormwater controls at a minimum of once per quarter. Inspections will also be conducted after significant rainfall events to evaluate potential erosion. These inspections will include the stormwater/sediment detention basins and stormwater ditches at a minimum. The stormwater/sediment detention basins will be cleaned when the level of excess sediment reaches two (2) feet on the outlet structure. All areas of concern will be corrected within thirty (30) days so that the integrity and effectiveness of the stormwater controls is maintained. The run-on and run-off control systems are illustrated on the Construction Drawings (Dwg. No. 01, 1168-D27, Sheet C-7.0 and C-8.2 dated May 2018). The Storm Drainage Report for the Greenpointe Landfill Stormwater Improvements, dated June 2019, are included in Attachment 10.

#### **4.4 Fire Prevention**

Open burning is not permitted at the Greenpointe C&D Landfill. In the event of a fire in the debris, the burning materials will be covered with a soil cover if the fire is deemed manageable. If the fire is determined to be unmanageable for landfill personnel, the Three and Twenty fire department will be notified. The landfill facility is served by the Greenpointe Fire Department, which is located approximately two (2) miles from the landfill. A letter dated April 16, 2018 stating the fire department will serve the Greenpointe C&D Landfill is included in Attachment 11.

#### **4.5 Vector Control**

The monthly soil cover of the C&D debris should be sufficient to control and maintain conditions that are unfavorable for the habitation and production of insects, rodents, and other pests. In the event that conditions warrant, the C&D debris will be covered more frequently. If a significant infestation of pests is discovered, a pest control company will be contacted.

#### **4.6 Odor Control**

The nature of C&D debris typically does not result in unpleasant odors. The monthly soil cover of the C&D debris should be sufficient to control unpleasant odors at the C&D Landfill. If unpleasant odors persist, the C&D debris will be covered more frequently.

#### **4.7 Dust Control**

A water truck will be used on-site to control dust emissions on the access roads in periods of drought, or when deemed necessary. This equipment will be used on an as-needed basis.

#### **4.8 Litter Control**

The nature of C&D waste typical does not result in significant concerns regarding waste escaping the landfill boundaries during flooding or high wind events. However, adequate control over litter will be maintained by monthly cover and daily inspections of the surrounding area. If conditions warrant, temporary fencing will be installed along the perimeter of the landfill. In addition to fences, waste from the C&D Landfill that accumulates around the Landfill facility is collected on a regular basis by Landfill personnel. Roadways, vegetated channels, and other exposed areas are cleaned of waste or debris on a regular basis.

#### **4.9 Hours of Operation**

The use of the natural barriers and access gates will control promiscuous dumping and unauthorized access to the Greenpointe C&D Landfill. Access to the Greenpointe C&D Landfill is limited to the main gate near the scale house. The operation times for the Greenpointe Landfill are from 7:00 AM to 5:00 PM on Monday, Tuesday, Wednesday, and Thursday, 7:00 AM to 4:30 PM on Friday; and Greenpointe Landfill is closed on Saturday and Sunday. A sign indicating the Landfill operating hours will be posted at the entrance to the Greenpointe C&D Landfill. Roads leading to the facility are secured by locked gates, and the facility is secured by fencing. Security lights remain on at Greenpointe Landfill to further secure the area and to deter illicit activities.

#### 4.10 Waste Placement

##### a) Cover Requirements

The C&D debris will be covered with a minimum of six (6) inches of compacted on-site soils at least once every thirty (30) days. If conditions warrant, the debris will be covered more frequently. The on-site soil is mostly sandy loams with intermittent with fine sandy loam and clayey sand layers, and will be stockpiled in a location convenient to the working face of the landfill. Additional cover soil will be borrowed from the Proposed Stockpile Area northwest of the existing Class Two C&D Landfill. The approximate location of this borrow area is illustrated on the Site Plan (DWG No. 01, 1168-D21 Sheet C-3.0).

##### b) Equipment

The following equipment will be available for use during disposal activities at the proposed Greenpointe C&D Landfill:

One (1) CAT 950G Loader

One (1) CAT 816C Compactor

One (1) CAT 216B Skidsteer

One (1) John Deere 790 Tractor

This equipment is considered to be adequate to perform the daily operations at the landfill. Repairs of broken equipment will be conducted as soon as possible or backup equipment will be available within 24 hours. If additional equipment is needed, acquisition of the necessary equipment will be made.

#### 4.11 Fill Progression Plan

Upon closure of Greenpointe Class II C&D Landfill Cell One it is proposed that Cell Two will begin receiving waste. The Proposed Cell Two is located on the western portion of the Landfill Property, and is approximately eighteen (18) acres. In the event that the Proposed Cell Two is not ready to receive waste upon the Closure of Cell One, waste placement will be diverted to the nearest open C&D

Landfill. The estimated capacity of Cell Two is approximately 625,166 cubic yards, and the expected lifetime of this cell is between thirteen (13) and twenty-seven (27) years. In order to prepare for the proposed Cell Two, the area will continue to be excavated and the on-site soils will be utilized as cover for the current Cell One. The C&D debris will be placed in two (2) foot lifts and compacted with a landfill compactor or bulldozer. The debris will be placed approximately eight (8) feet in height before waste is placed in another area. Unloading of C&D debris will be limited to the working face of the landfill, which will be limited to the smallest area possible to allow for safe operation of equipment. The slope of the working face will not exceed three (3) feet horizontal to one (1) foot vertical to ensure safe working conditions.

#### **4.12 Elevation Control**

A Topographic Survey was completed by F&S, dated February 8, 2017 and permanent surveying benchmarks were identified and placed (Attachment 1). Elevation control throughout the landfill filling process will be provided via annual volume calculations which indicate the current elevations of the landfill. Daily elevation control will be provided by adequate training of Greenpointe Landfill personnel.

#### **4.13 Potential Disposal Materials**

The facility will accept only those wastes listed in Appendix I of *R.61-107.19, List of Acceptable Wastes*. Items listed in Appendix II of *R.61-107.19* or Appendix I materials which have been in direct contact with or that may contain petroleum products, lead-based paint, or any hazardous constituents listed in the South Carolina Hazardous Waste Management Regulations *R.61-79.261* are prohibited. The list of Acceptable and Unacceptable Waste are included in Attachment 12.

## 5.0 CONTINGENCY PLAN

### 5.1 General Information

The Contingency Plan for the Greenpointe C&D Landfill has been developed to protect human health and the environment from fires or any unplanned sudden or non-sudden release of hazardous waste to the air, soil, or surface water. The information herein is in accordance with the requirements for a Contingency Plan, as contained in Solid Waste Regulation R.61-107.19.

The Contingency Plan is for the Greenpointe C&D Landfill, located one (1) mile north of Old Greenville Highway Extension (SC Highway 88) on Hamlin Road near the City of Easley, South Carolina. The facility will accept only those wastes listed in Appendix I of R.61-107.19, which have not come into contact with hazardous constituents, petroleum products, or lead-based paints from Anderson County. The list of acceptable wastes is included in Attachment 12.

### 5.2 Greenpointe C&D Landfill Emergency Coordinators

Vice President, Radford Jenkins will serve as the Primary Emergency Coordinator (PEC), the Landfill Supervisor will serve as the Secondary Emergency Coordinator (SEC) in the event that the PEC is not available to respond to an emergency situation. If an emergency situation develops, the discoverer will immediately contact the Primary or the Secondary Emergency Coordinator. The Emergency Coordinators (EC) shall be South Carolina Certified Landfill Operators and will have complete authority to commit all available resources listed in the plan. In the event a situation occurs beyond the capabilities of the landfill personnel, the coordinator will contact the resources listed below as soon as possible.

Emergency Medical Service (EMS)	911
Three and Twenty Fire Department	(864) 859-7926
SCDHEC – Upstate Anderson EQC District	(864) 260-5585

### 5.3 Equipment

Repairs of broken equipment will be conducted as soon as possible or backup equipment will be available within 24 hours. If additional equipment is needed, acquisition of the necessary equipment will be made.

### 5.4 Implementation

If an emergency situation develops at the Greenpointe C&D Landfill, the person discovering the emergency should contact the Emergency Coordinator immediately. The decision to implement the Contingency Plan depends upon whether or not a situation represents a threat to human health or the environment. The Contingency Plan should be implemented if any of the following situations occur:

1. On-site Personnel Injury
2. Fire
3. Spills or Material Release (Non-hazardous, hazardous, sanitary, etc.)
4. Receipt of Unauthorized Waste
5. Unfavorable Aesthetic Conditions (dust, litter, odor, noise, vectors)
6. Equipment Breakdown
7. Unusual Traffic Conditions

### 5.5 Financial Feasibility

The procedures outlined in this Contingency Plan are technically and financially feasible since it utilizes equipment typically required to operate a landfill. If conditions warrant specialized or additional equipment, the appropriate emergency agency will be contacted to assist landfill personnel in remediating the situation.

### 5.6 Emergency Response Procedures

The Emergency Coordinator will immediately evaluate the potential effects of an emergency situation. The Emergency Coordinator will obtain the following information as indicated below and assess the landfill's ability to handle the situation.

1. The health condition of personnel potentially affected.
2. The type of material released, spilled, or burning.
3. The location of the release, spill, or fire.
4. The quantity and rate of release.
5. The direction in which the spill release or fire/smoke is heading.
6. The location of on-site personnel who might have been in the area.
7. The potential for fire or fume release.
8. The potential for the situation (fire) to intensify or spread

### **5.7 On-Site Accident/Injury Response**

In the event of an accident or injury to landfill personnel, the following procedures will be implemented:

1. Notify the Emergency Coordinator immediately, even if the injury appears to be minor.
2. Take action to prevent further injury/damage to personnel or property.
3. Provide emergency first aid and seek medical attention, if required.
4. If the injury is deemed serious, obtain additional medical assistance by notifying the EMS. If medical attention is required, but ambulance service is not needed, the injured party should be transported to the nearest medical facility.
5. The Primary Emergency Coordinator will investigate the accident to gather the facts and determine the causes of the accident.
6. The SCDHEC, Upstate Anderson EQC District will be notified.

### **5.8 Fires within the Landfill**

Specified Greenpointe C&D Landfill personnel will be on standby during all emergency situations. If a fire is observed, emphasis will be placed on preventing the fire from spreading. Greenpointe C&D Landfill personnel will carry out the firefighting effort until outside assistance arrives. The Three and Twenty Fire Department is located approximately two (2) miles northeast from the landfill and will be contacted immediately upon observance of smoke and flames at the landfill.

In the event of a fire/explosion at the landfill, the following procedures will be implemented:

1. Alert persons in the area of the existence of fire and evacuate the area.
2. Notify the Emergency Coordinator immediately.
3. Do not attempt to extinguish the fire without assistance unless it is very small and of known origin.
4. If the fire is deemed manageable, the fire will be extinguished by covering the burning waste with soil.
5. If the fire is deemed unmanageable, the area will be evacuated and the fire department will be notified.
6. Incoming traffic will not be allowed entrance to the landfill until the fire is extinguished and the area is deemed safe by the Emergency Coordinator.
7. Notify the SCDHEC Upstate Anderson EQC District of the incident if the fire department responded to the facility.

If a fire occurs, particularly one involving toxic materials, and it is determined to be a potential hazard to public health, people should be evacuated after it is considered and authorized by local emergency response agencies.

An “all clear” signal will be given, by voice communication only when the fire has been extinguished and there is no longer a personnel safety hazard. If the fire is of such magnitude that outside resources are necessary, the Greenpointe Fire Station will determine when the emergency has passed and consult with the Emergency Coordinator before the “all clear” signal is given. All equipment used in the emergency must be cleaned and available for use prior to the resumption of normal operation.

### **5.9 Spills or Material Release**

In the event of a chemical spill or hazardous or toxic material release, the following procedures will be implemented to allow a rapid and safe response to the emergency situation. Greenpointe C&D Landfill personnel will follow with the



procedures outlined below. While each response will be incident specific, the basic steps of an incident response will be as follows:

1. Remove unnecessary personnel.
2. Report the incident.
3. Assess possible hazards to human health or the environment that may result from the incident. This assessment must consider both direct and indirect effects of the incident (e.g., the effects of any toxic, irritating, or asphyxiating gases that are generated or the effects of any hazardous surface water runoff from water or other chemical agents used to control fire and heat-induced explosions).
4. If the spilled materials identity is unknown, assume the worst case and request assistance.
5. Use appropriate personal protective equipment called for in the Safety Data Sheet (SDSs), Department Of Transportation Response Guide or on the container label.
6. Approach from upwind.
7. Avoid contact with the spilled material (i.e., Do not walk through, kneel or touch it).
8. Control the spill by righting overturned containers, closing valves, etc.
9. Contain the chemical by surrounding the area with an inert material such as sand or an absorbent material. Recover useable materials.
10. If personnel come in contact with the chemicals, follow the first aid instructions in the Safety Data Sheets or on the container.
11. Decontaminate personal protective equipment or dispose of expendable items.
12. Dispose of spilled materials in accordance with local, state, and federal regulations.

Specifically trained personnel should be utilized in spill response involving unknown materials, extremely toxic materials, explosive atmospheres, oxygen deficient atmospheres and/or confined entry. If sufficient product/material

information is not available and ambient monitoring equipment is not available, always assume the worst case, request assistance and stay upwind.

If an employee discovers a spill, the following procedure will be observed:

1. Notify the Emergency Coordinator immediately, even if the spill or release appears to be minor.
2. Immediate action will be taken to control/limit the spread of the spill or release.
3. Perform appropriate cleanup procedures.
4. The Emergency Coordinator will investigate the incident to gather the facts and causes of the spill or release.

#### **5.10 Unauthorized Hazardous and Infectious Waste in Landfill**

In the event that hazardous or infection waste is discovered in the landfill, the following procedures will be observed:

1. Notify the Emergency Coordinator immediately, even if it appears to be minor.
2. The area will be evacuated and cordoned off.
3. Landfill personnel should not attempt to identify or move the material.
4. The Emergency Coordinator will investigate the incident to gather the facts in an attempt to determine the responsible party.
5. If the responsible party is found, they will be responsible for proper removal and disposal of the waste.
6. If no responsible party is found, Wasteco, Inc. will assume responsibility for characterization and proper disposal of the waste.
7. Notify the SCDHEC Upstate Anderson EQC District

#### **5.11 Inoperable Landfill Periods**

In the event of any unforeseen circumstance that should render the landfill unable to accept incoming waste, the waste will be taken to another permitted C&D Landfill in the area.

### **5.12 Prevention of Recurrence**

Corrective and preventive actions will be carried out to prevent the recurrence of another contingency response. Greenpointe C&D Landfill personnel will conduct training programs addressing the specific actions to be taken in the event of an emergency. The reinstatement of normal operations will cease until all emergencies are controlled and conditions are deemed safe to continue operations. The EC will determine when operations can resume.

### **5.13 Emergency Equipment**

Emergency equipment is located throughout the site. Personnel at the Greenpointe Landfill will have several means for fire protection including dry chemical Type A, B, and C fire extinguishers. Type A is capable of extinguishing fires involving ordinary combustible material. Type B is capable of extinguishing fires involving flammable liquids and gases. Type C is capable of extinguishing fires involving electrical equipment. The Greenpointe C&D Landfill will also be equipped with one (1) water truck for firefighting purposes. Equipment for use in containing and cleaning up spills will be located in the scale house building. First aid supplies will also be maintained in the scale house and are available from the Emergency Coordinator.

An air horn will be present on site and will be used to initiate evacuation of the landfill in the event of an emergency. Two-way radios will be maintained on site and kept in the scale house. Protective clothing and equipment will be provided to protect employees during normal and emergency operations. Hard hats, protective eyewear, reflective vests, and steel-toed rubber boots or shoes are the minimum protective clothing required.

### **5.14 Evacuation Plan**

The Emergency Coordinator is responsible for determining whether or not an emergency situation warrants evacuation of the facility. If conditions warrant, the following actions will be taken:

1. The Emergency Coordinator gives the evacuation alarm (a continuous blast on an air horn). At that time, no one will be permitted into the site. All non-emergency vehicle traffic within the landfill will be halted.
2. All personnel (visitors, contractors, and employees) will assemble and leave through the main gate.
3. All persons will be accounted for by their supervisors. Communication by use of the two-way radios will assist the Emergency Coordinator in an alternate exit route if the first choice is inaccessible.
4. The Emergency Coordinator will make a checklist of all Greenpointe C&D landfill, visitors and contractors.
5. Re-entry to the fenced area will be allowed only after the “all clear” signal is given by the Emergency Coordinator. A verbal signal will be given for re-entry into the site.
6. Drills may be held at least annually to practice all the procedures discussed in the plan.

#### **5.15 Report Requirements**

In the event of an emergency event that requires implementing the Contingency Plan, SCDHEC will be notified immediately by phone. A written report detailing the event will be placed in the Greenpointe C&D Landfill record and a copy will be submitted to SCDHEC within fifteen (15) days of the incident.

## 6.0 MONITORING AND REPORTING REQUIREMENTS

### 6.1 Groundwater Monitoring

The Groundwater Detection Monitoring Plan has been included as Attachment 13.

#### a) Groundwater Table

The cell floor of the proposed C&D Landfill Cell will be a minimum of two (2) foot above the seasonal high groundwater table. Based on monitoring well measurements taken since 2010, the groundwater across the Greenpointe Landfill site ranges from 795.86 feet above mean sea level (PZ 4) to 839.39 feet above mean sea level, as illustrated in the Potentiometric Map included as Exhibit J. The water table ranges from 267 feet to 354.25 feet above mean sea level versus the existing base grade of 803 feet to 837 feet respectively, in the vicinity of the Greenpointe C&D Landfill.

### 6.2 Corrective Action Implementation

If it is determined that the C&D Landfill poses an actual or potential threat to human health or the environment, upon notification by SCDHEC, Wasteco, Inc. will implement a corrective action program approved by SCDHEC.

### 6.3 Contingency Plan Implementation

The Contingency Plan outlined in Section 5.0 will be implemented if conditions warrant. Upon implementation of the Contingency Plan, Wasteco, Inc. County will immediately notify SCDHEC by telephone and follow with written confirmation.

### 6.4 Daily Records

Wasteco, Inc. will maintain daily records of the actual weight of C&D debris received and particular grid location of the area currently being used for disposal at the Greenpointe C&D Landfill.

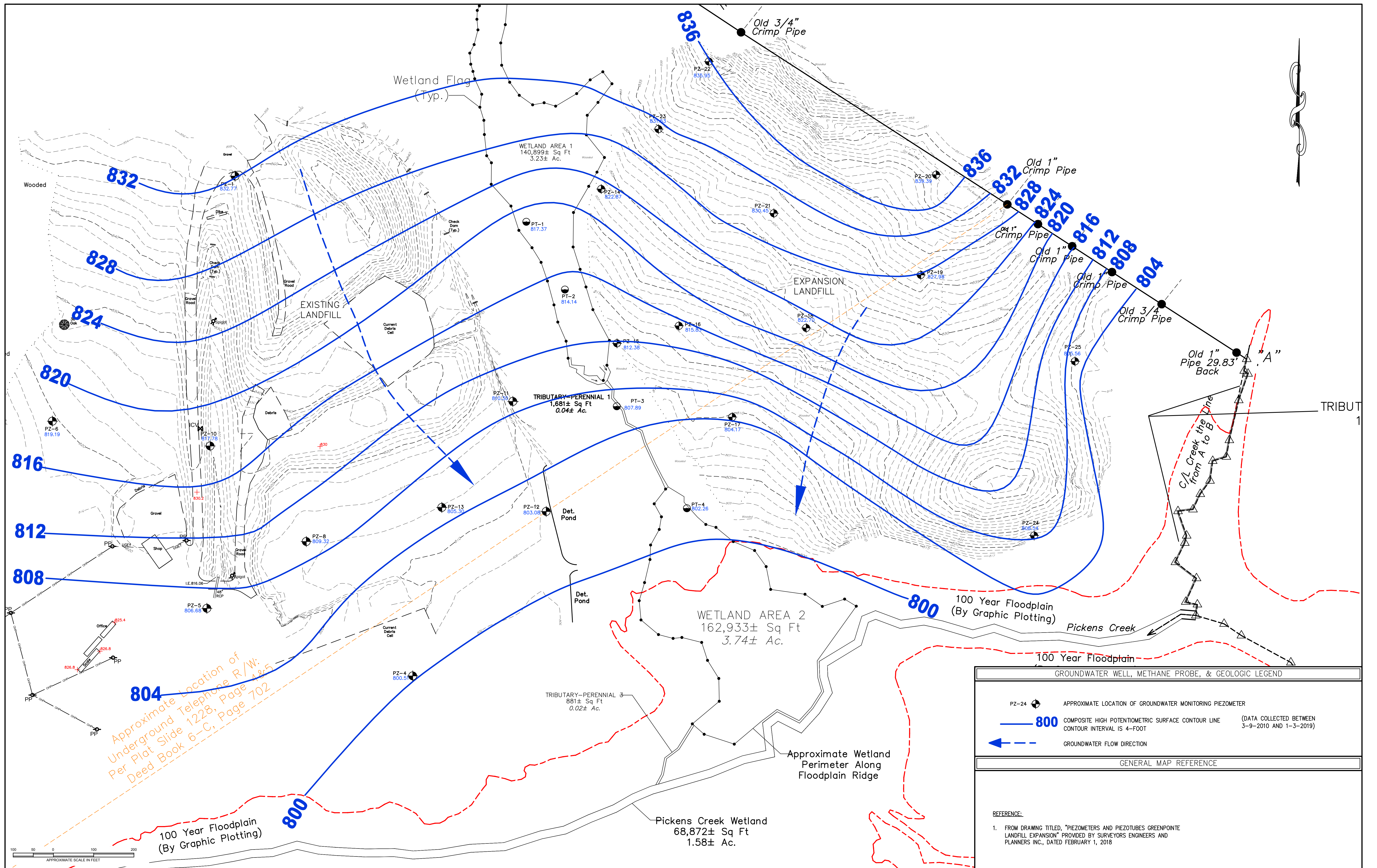

No.	REVISIONS DESCRIPTION	BY

<b>DRAWN:</b> IAI	<b>DATE:</b> 4-22-19
<b>CHECKED:</b> DPO	<b>CAD FILE:</b> GREENPOINTE-02WIMFIG4
<b>APPROVED:</b>	<b>JOB NO:</b> J18-11684-02

**BLE** | **BUNNELL LAMMONS ENGINEERING**

6004 Ponders Court, Greenville, SC 29615  
Phone: (864) 288-1265 Fax: (864) 288-4430

COMPOSITE HIGH GROUNDWATER POTENTIOMETRIC SURFACE MAP  
GREENPOINTE CLASS II LANDFILL  
ANDERSON COUNTY, SOUTH CAROLINA

**6.5 Annual Progress Report**

Wasteco, Inc. will submit an annual progress report, in a format approved by the Department, for the fiscal year beginning on July 1 and ending June 30. The report will be submitted to the Department on or before October 1, and will include the following information:

- a) The actual weight of C&D debris received per month;
- b) A description of the capacity of the C&D landfill used in the previous fiscal year;
- c) The remaining permitted capacity of the C&D landfill.

Wasteco, Inc. will maintain this information for a period of not less than five (5) years.

**6.6 Permit Review**

Six (6) months prior to the Department review of the facility's permit, in accordance with Section I of Solid Waste Regulation R.61-107.19 – Part IV, Wasteco, Inc. will submit a topographic survey map of the site that illustrates the contours at the beginning and the end of the period since the last permit review.

## 7.0 CLOSURE

### 7.1 Final Cover Application

Within one (1) month following the last receipt of C&D debris at the C&D Landfill, the application of the final cover will begin. A minimum of two (2) feet of earthen material will be placed over the debris with a minimum three percent (3%) but no greater than five percent (5%) surface slope. The cover on the side slopes will not exceed three (3) horizontal feet to one (1) vertical foot. The maximum area requiring final cover will be a total of approximately forty seven (47) acres. Unless otherwise approved by the Department, the application of the final cover will be completed within six (6) months of the last receipt of C&D debris at the landfill. Wasteco, Inc. will maintain the integrity of the final cover.

### 7.2 Grassing

The finished surface of the final cover of the C&D Landfill will be seeded to provide vegetative cover on the landfill cap (Table 2). Areas ready for planting between August 16 and February 28 shall be planted with a temporary cover of Schedule No. 2. At the acceptable seasons for planting Schedule No.1, the turf shall be destroyed by reworking the soil, and Schedule No. 1 seeding established as specified herein. Use Rate A on slopes of 5' horizontal to 1' vertical in height and use Rate B on slopes less than 5' horizontal and 1' vertical. The total pounds of seed per acre are the sum total shown for all varieties of seed opposite the planting dates. Prior to seeding, lime will be added at the rate of 1,000 pounds per acre and fertilizer (4-12-12) will be added at the rate of 500 pounds per acre, or as otherwise determined necessary by soil tests.

### 7.3 Signage

Within five (5) days of closure of the C&D Landfill, Greenpointe will post signs at the landfill entrance stating the C&D landfill is no longer in operation

### 7.4 Verification of Closure

Upon closure of the Greenpointe C&D Landfill, and within ten (10) days of the completion of grading and seeding activities, a professional engineer licensed



in the State of South Carolina will submit to the Department verification that the Greenpointe C&D Landfill has been properly closed in accordance with the requirements of Solid Waste Regulation *R.61-107.19 Part IV*, and the facility's permit. The certification will include thickness measurements of the final cover at a rate of one (1) per 10,000 square feet.

#### **7.5 Corrective Action Plan**

If environmental problems associated with the Greenpointe C&D Landfill are detected and confirmed by the Department, Wasteco, Inc. will submit to SCDHEC for review and approval, a corrective action plan and a schedule of compliance for implementing the plan.

#### **7.6 Record of Facility**

Within thirty (30) days of SCDHEC's approval of final closure, Wasteco, Inc. will submit to the local authority with jurisdiction over land use and to SCDHEC, a plat showing the final boundaries of the waste disposal area of the closed landfill including the latitude and longitude, and a record of the type, location, and quantity of solid waste disposed of at the facility. Wasteco, Inc. will record a notation on the deed for the Greenpointe C&D landfill property that will perpetually notify any potential purchaser of the property that the land or a portion thereof has been used for disposal of solid waste. A copy of the revised deed will be forwarded to SCDHEC.

## 8.0 POST CLOSURE CARE PLAN

### 8.1 General

Following the closure of the Greenpointe C&D Landfill, Wasteco, Inc. will provide post closure care for the facility. The property will be managed as open green space during post closure, which will not affect the integrity of the final cover. The contact office for the post closure period will be as follows:

Wasteco, Inc.  
510 Hamlin Rd.  
Easley, SC 29642  
Telephone: (864) 233-0100

### 8.2 Inspection and Maintenance of Final Cover

Quarterly visual inspections of the C&D Landfill cap will occur during the post closure care period. These inspections are to evaluate the landfill for signs of settlement, lack of vegetative cover, and presence of possible erosion area. Wasteco, Inc. personnel will conduct these inspections. Inspections may also be conducted after significant rainfall events to evaluate erosion. All areas of concern will be corrected within thirty (30) days so that the integrity and effectiveness of the final cover is maintained. In addition, grassed areas will be mowed on an as-needed basis, to facilitate visual inspections of the landfill cap.

### 8.3 Inspection and Maintenance of Stormwater/Sediment Controls

Quarterly visual inspection of the stormwater/sediment controls will be conducted. Inspections will also be conducted after significant rainfall events to evaluate erosion and sedimentation. The inspections will include the stormwater/sediment detention basins, ditches and letdown channels, at a minimum. The stormwater/sediment basin is to be excavated upon the accumulation of two (2) feet of sediment in the bottom of the basin. All areas of concern will be corrected within thirty (30) days so that the integrity and effectiveness of the stormwater/sediment controls are maintained.

- LEGEND**
- Iron Pin, New
  - Iron Pin, Old
  - Power Pole
  - Sanitary Sewer Manhole
  - Light Pole
  - Valve
  - Gas Meter
  - Nail and Bottle Cap, New Unless Otherwise Noted
  - PK Nail, Old (Unless Otherwise Noted)
  - Unmarked Traverse Point
  - Wetland Flag
  - Monitoring Well
  - Water Spigot
  - Irrigation Control Valve
  - Piezometer and Designation

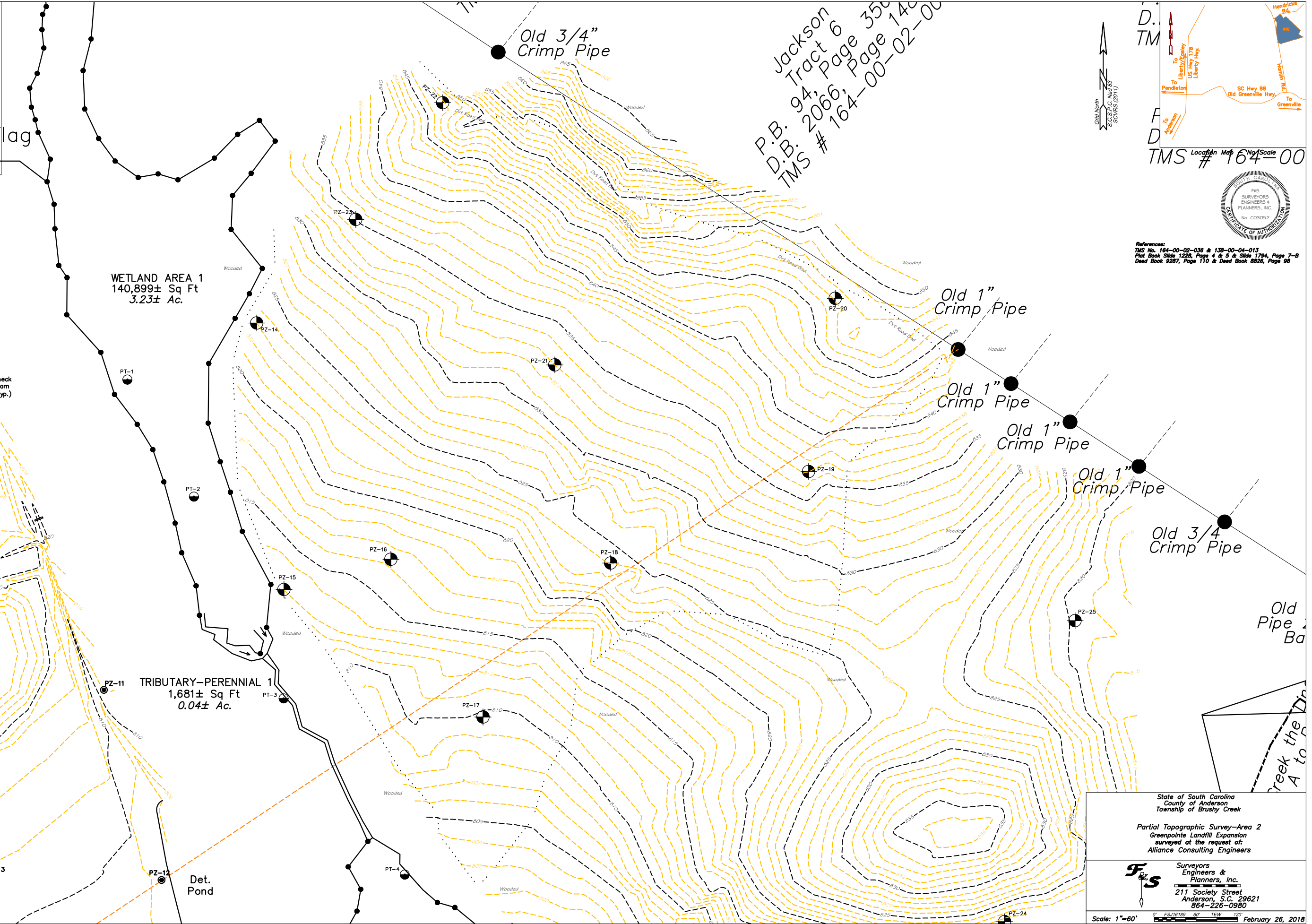
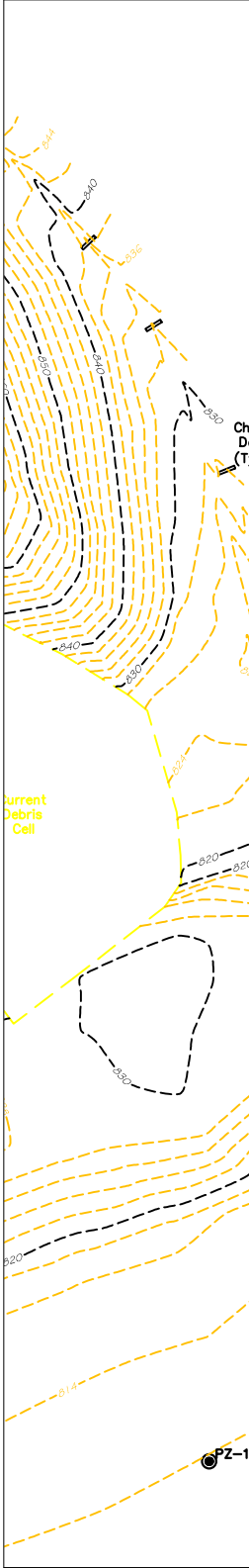

Jackson  
P.B. 94, Page 350  
D.B. 2066, Page 140  
TMS # 164-00-02-00

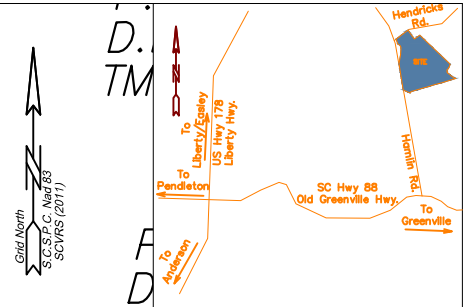

TMS Location Map No. Scale  
# 164-00



References:  
TMS No. 164-00-02-036 & 138-00-04-013  
Plat Book Side 1228, Page 4 & 5 & Side 1794, Page 7-8  
Deed Book 5287, Page 110 & Deed Book 8526, Page 98

State of South Carolina  
County of Anderson  
Township of Brusty Creek

Partial Topographic Survey—Area 2  
Greenpointe Landfill Expansion  
surveyed at the request of:  
Alliance Consulting Engineers

**F&S**  
Surveyors  
Engineers &  
Planners, Inc.  
211 Society Street  
Anderson, S.C. 29621  
864-226-0980

Scale: 1"=60' February 26, 2018

LEGEND

Iron Pin, New	○
Iron Pin, Old	●
Power Pole	○
Sanitary Sewer Manhole	○
Light Pole	○
Valve	○
Gas Meter	○
Nail and Bottle Cap, New Unless Otherwise Noted	○
PK Nail Old (Unless Otherwise Noted)	○
Unmarked Traverse Point	△
Wetland Flag	■

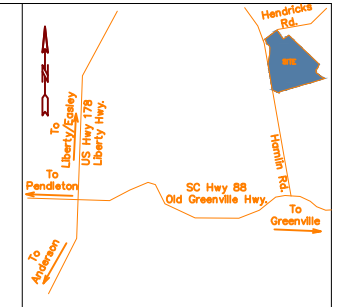

LINE TABLE		
LINE	LENGTH	BEARING
L1	29.63	S11°59'21"W
L2	12.14	S52°19'01"E
L3	69.77	S19°25'51"W
L4	101.87	S13°14'20"W
L5	42.02	S10°05'56"W
L6	35.45	S73°11'15"W
L7	49.64	S07°42'57"W
L8	40.89	S36°15'58"W
L9	42.47	S25°16'50"W
L10	37.43	S83°22'22"W
L11	64.35	S19°27'59"E
L12	18.60	S14°27'05"W
L13	53.13	S25°59'43"W
L14	66.01	S52°34'53"E
L15	64.40	S24°29'36"W
L16	29.62	S77°11'21"E
L17	27.45	S07°54'15"W
L18	73.10	S73°22'46"E
L19	51.79	S56°00'05"E
L20	140.04	S61°25'37"E
L21	59.59	S34°40'10"E
L22	68.85	S72°04'09"E
L23	95.66	S46°10'50"E
L24	131.77	S71°50'05"E
L25	114.71	S80°06'56"E

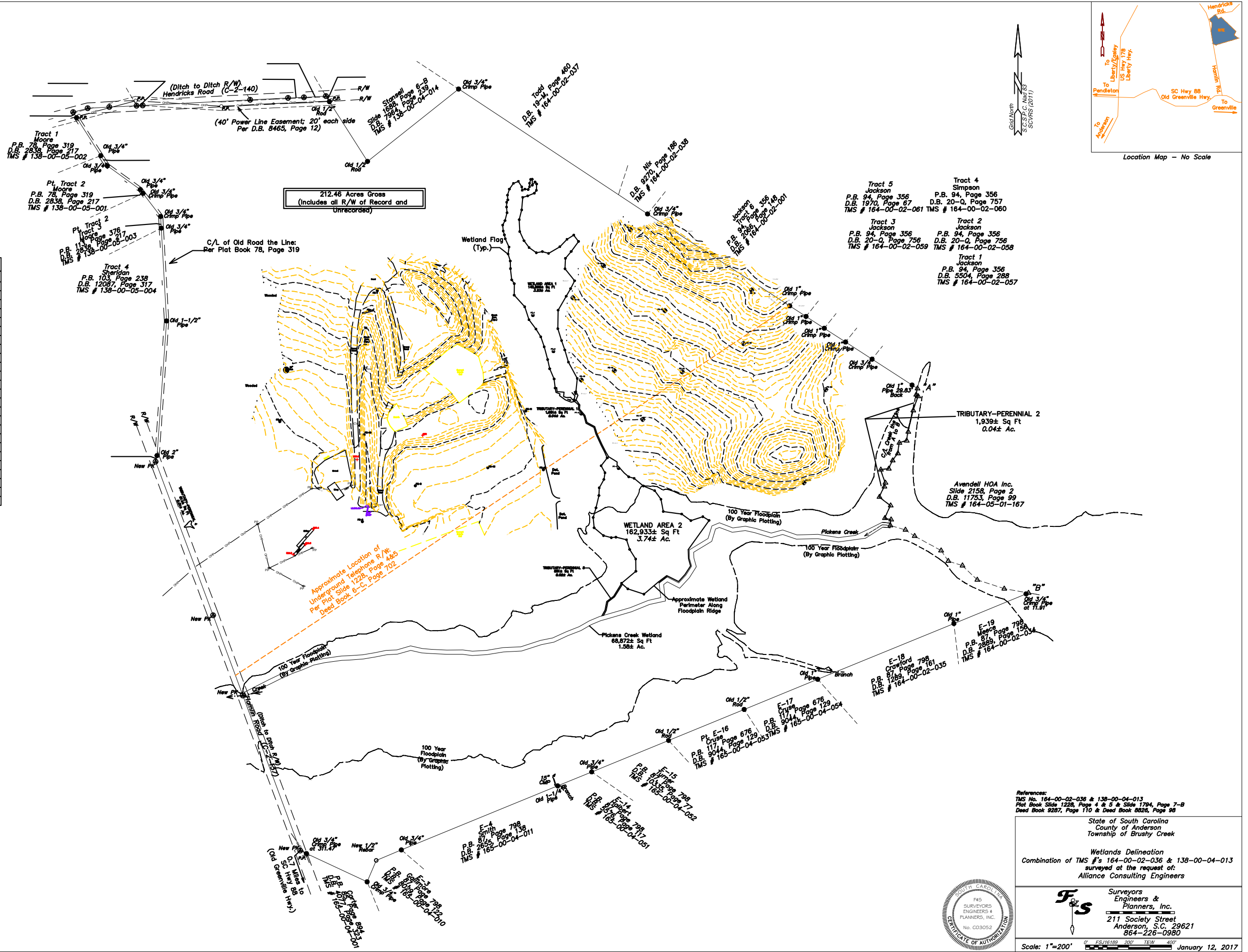

References:  
TMS No. 164-00-02-036 & 138-00-04-013  
Plat Book Slide 122B, Page 4 & 5 & Slide 179A, Page 7-B  
Dead Book 9297, Page 110 & Dead Book 8526, Page 98

State of South Carolina  
County of Anderson  
Township of Brusty Creek

**Wetlands Delineation**  
Combination of TMS #'s 164-00-02-036 & 138-00-04-013  
surveyed at the request of:  
Alliance Consulting Engineers



**F.S. Engineers & Planners, Inc.**  
211 Society Street  
Anderson, S.C. 29621  
864-226-0980

Scale: 1"=200' FS16189 2007 TEW 400' January 12, 2017

- LEGEND**
- Iron Pin, New
  - Iron Pin, Old
  - Power Pole
  - Sanitary Sewer Manhole
  - Light Pole
  - Valve
  - Gas Meter
  - Nail and Bottle Cap, New Unless Otherwise Noted
  - PK Nail Old (Unless Otherwise Noted)
  - Unmarked Traverse Point
  - Wetland Flag
  - Monitoring Well  MW
  - Water Spigot  Spigot
  - Irrigation Control Valve  ICV
  - Piezometer and Designation  PZ-10

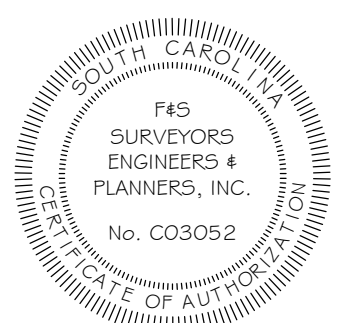
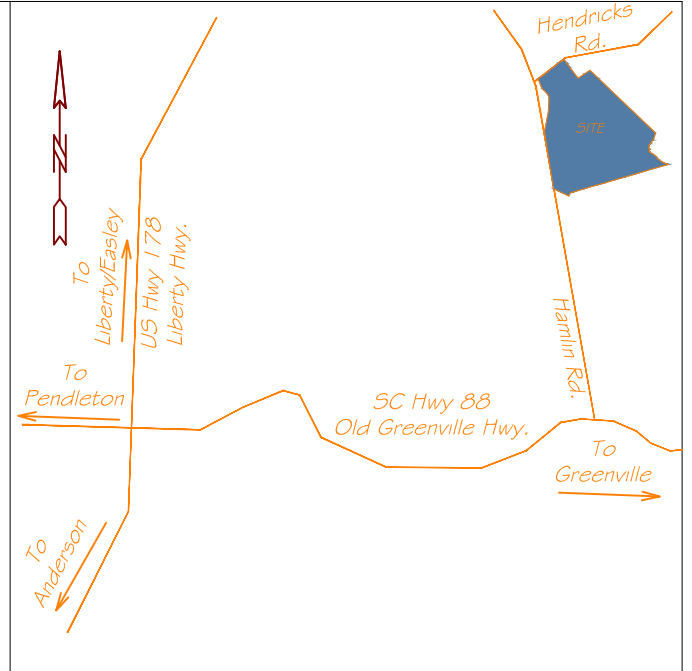
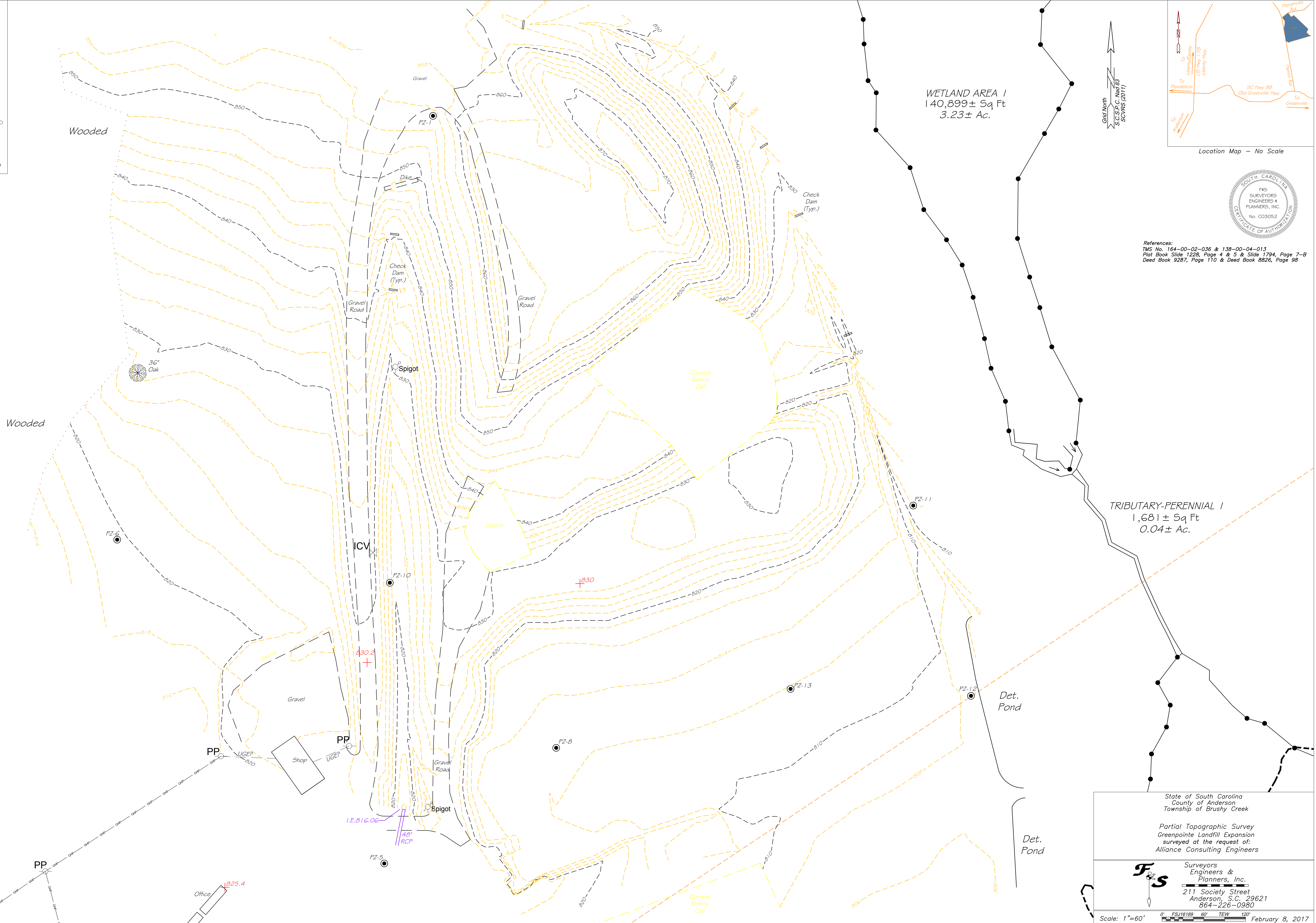

References:  
 TMS No. 164-00-02-036 & 138-00-04-013  
 Plat Book Slide 1228, Page 4 & 5 & Slide 1794, Page 7-B  
 Deed Book 9287, Page 110 & Deed Book 8826, Page 98

State of South Carolina  
 County of Anderson  
 Township of Brushy Creek

Partial Topographic Survey  
 Greenpoint Landfill Expansion  
 surveyed at the request of:  
 Alliance Consulting Engineers

**F&S**  
 Surveyors  
 Engineers &  
 Planners, Inc.  
 211 Society Street  
 Anderson, S.C. 29621  
 864-226-0980

Scale: 1" = 60' February 8, 2017

LEGEND

Iron Pin, New	○
Iron Pin, Old	●
Power Pole	⊙
Sanitary Sewer Manhole	⊞
Light Pole	⊕
Valve	⊗
Gas Meter	⊘
Nail and Bottle Cap, New Unless Otherwise Noted	⊚
PK Nail Old (Unless Otherwise Noted)	⊛
Unmarked Traverse Point	△
Wetland Flag	■

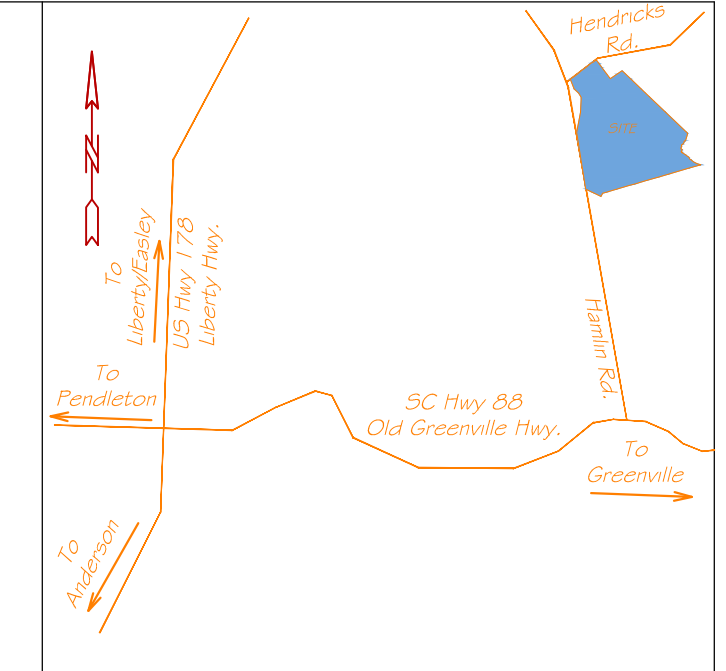

LINE TABLE

LINE	LENGTH	BEARING
L1	29.63	S11°59'21"W
L2	12.14	S52°19'01"E
L3	69.77	S19°25'51"W
L4	101.87	S13°14'20"W
L5	42.02	S10°05'56"W
L6	35.45	S73°11'15"W
L7	49.64	S07°42'57"W
L8	40.89	S36°15'58"W
L9	42.47	S25°16'50"W
L10	37.43	S83°22'22"W
L11	64.35	S19°27'59"E
L12	18.60	S14°27'05"W
L13	53.13	S25°59'43"W
L14	66.01	S52°34'53"E
L15	64.40	S24°29'36"W
L16	29.62	S77°11'21"E
L17	27.45	S07°54'15"W
L18	73.10	S73°22'46"E
L19	51.79	S56°00'05"E
L20	140.04	S61°25'37"E
L21	59.59	S34°40'10"E
L22	68.85	S72°04'09"E
L23	95.66	S46°10'50"E
L24	131.77	S71°50'05"E
L25	114.71	S80°06'56"E

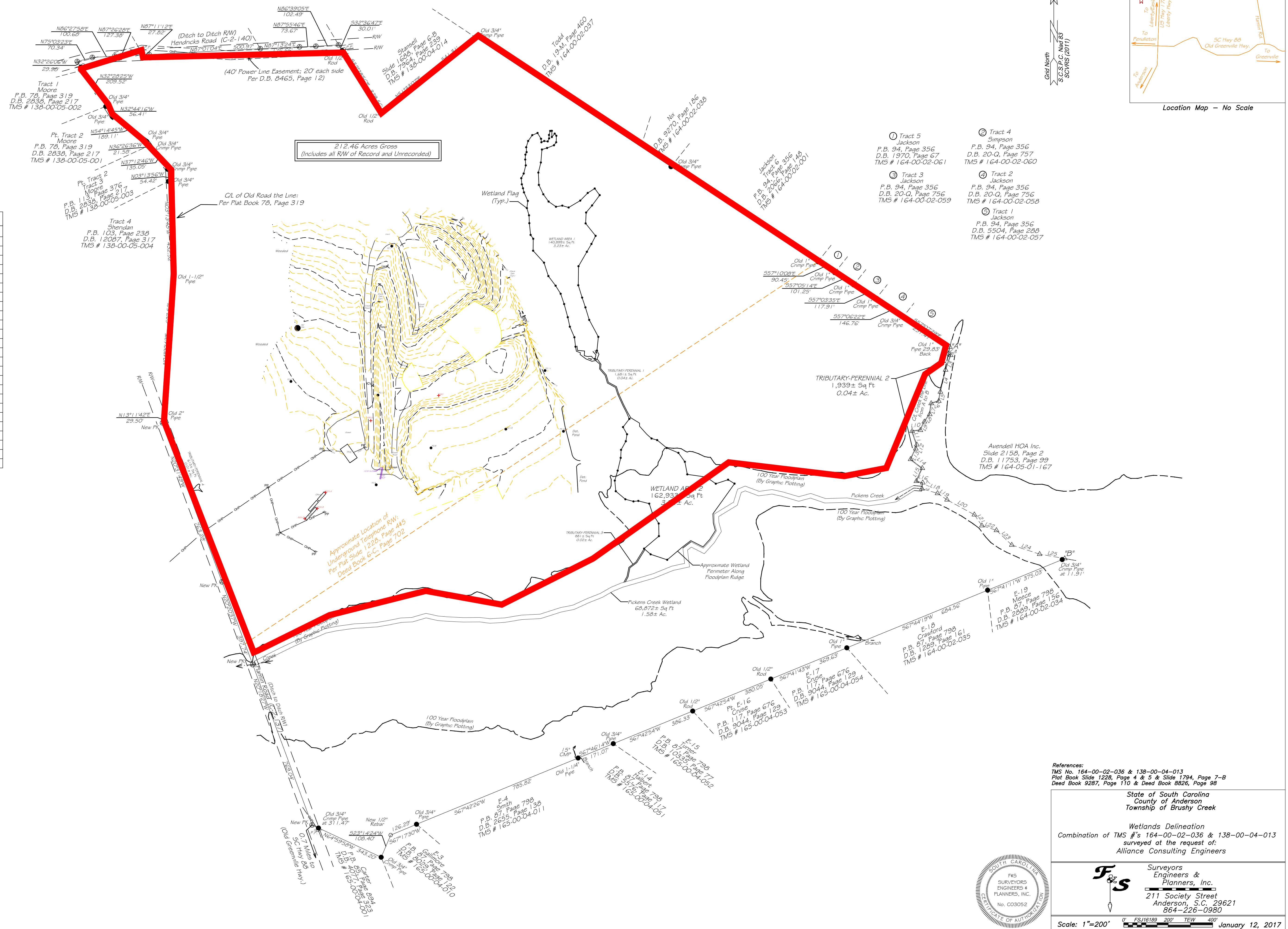

References:  
TMS No. 164-00-02-036 & 138-00-04-013  
Plat Book Slide 1228, Page 4 & 5 & Slide 1794, Page 7-8  
Deed Book 9287, Page 110 & Deed Book 8826, Page 98

State of South Carolina  
County of Anderson  
Township of Brushy Creek

Wetlands Delineation  
Combination of TMS #'s 164-00-02-036 & 138-00-04-013  
surveyed at the request of:  
Alliance Consulting Engineers

**FS**  
**Surveyors & Engineers, Inc.**  
**PLANNERS, INC.**  
211 Society Street  
Anderson, S.C. 29621  
864-226-0980

Scale: 1"=200'  
0' 100' 200' 300' 400'  
January 12, 2017



**DEPARTMENT OF THE ARMY**  
CHARLESTON DISTRICT, CORPS OF ENGINEERS  
1835 ASSEMBLY STREET, ROOM 865B-1  
COLUMBIA, SOUTH CAROLINA 29201

MAR 13 2018

Regulatory Division

Mr. Terron Edwards  
Froehling & Robertson, Inc.  
18 Woods Lake Road  
Greenville, South Carolina 29607

Dear Mr. Edwards:

This letter is in response to your request for an Approved Jurisdictional Determination (AJD) (SAC-2008-00559) received in our office on February 27, 2017, for a 212.46-acre site located southeast of the intersection of Hendricks Road and Hamlin Road, Anderson County, South Carolina (Latitude: 34.7279 °N, Longitude: 82.6125 °W). The site in question is shown on the enclosed depiction entitled "Waters of the US Sketch" and dated January 30, 2017 prepared by Froehling & Robertson, Inc. An AJD is used to indicate that this office has identified the presence or absence of wetlands and/or other aquatic resources on a site, including their accurate location(s) and boundaries, as well as their jurisdictional status pursuant to Section 404 of the Clean Water Act (CWA) (33 U.S.C. § 1344).

Based on a review of aerial photography, topographic maps, National Wetlands Inventory maps, soil survey information, and Wetland Determination Data Form(s), this office has determined that the referenced depiction accurately reflects the location and boundaries of the aquatic resources found within the site. The site in question contains 6.97 acres of jurisdictional wetlands and 4,743.7 linear feet of other waters of the United States that are subject to regulatory jurisdiction under Section 404 of the CWA.

Enclosed is a form describing the basis of jurisdiction for the area(s) in question. You should be aware that a Department of the Army (DA) permit from this office may be required for certain activities in the areas identified as subject to regulatory jurisdiction of the Corps of Engineers, and these areas may be subject to restrictions or requirements of other state or local government entities.

If a permit application is forthcoming as a result of this AJD, a copy of this letter, as well as the depiction should be submitted as part of the application. Otherwise, a delay could occur in confirming that an AJD was performed for the proposed permit project area. It should also be noted that some or all of these areas may be regulated by other state or local government entities. Specifically, you are encouraged to contact the South Carolina Department of Health and Environmental Control, Bureau of Water to determine the limits of their jurisdiction.

Please be advised that this AJD is valid for five (5) years from the date of this letter unless new information warrants revision before the expiration date. This AJD is an appealable action under the Corps of Engineers administrative appeal procedures defined at 33 CFR Part 331. The administrative appeal options, process and appeals request form is attached for your convenience and use.

This AJD has been conducted pursuant to Corps of Engineers' regulatory authority to identify the limits of Corps of Engineers' jurisdiction for the particular site identified in this request. This AJD may not be valid for the wetland conservation provisions of the Food Security Act of 1985. If you or your tenant are USDA program participants, or anticipate participation in USDA programs, you should request a certified wetland determination from the local office of the Natural Resources Conservation Service, prior to starting work.

In all future correspondence concerning this matter, please refer to file number SAC-2008-00559. A copy of this letter is being forwarded to certain State and/or Federal agencies for their information. If you have any questions concerning this matter, please contact me at 864-609-4324.

Sincerely,



Kristin B. Andrade  
Watershed Manager

Enclosures:

Approved Jurisdictional Determination Form  
Notification of Appeal Options  
"Waters of the US Sketch"

Copies Furnished:

Mr. Robert Jenkins  
BJ2, LLC  
P.O. Box 8028  
Greenville, South Carolina 29604

South Carolina Department of  
Health and Environmental Control  
Bureau of Water  
2600 Bull Street  
Columbia, South Carolina 29201



**APPROVED JURISDICTIONAL DETERMINATION FORM**  
**U.S. Army Corps of Engineers**

This form should be completed by following the instructions provided in Section IV of the JD Form Instructional Guidebook.

**SECTION I: BACKGROUND INFORMATION**

**A. REPORT COMPLETION DATE FOR APPROVED JURISDICTIONAL DETERMINATION (JD): 13-March-2018**

**B. DISTRICT OFFICE, FILE NUMBER, FILE NAME: JD Form 1 of 1; SAC-2008-00559 Greenpointe Landfill**

**C. PROJECT LOCATION AND BACKGROUND INFORMATION:**

State: South Carolina County/parish/borough: **Anderson County** City: **Easley**  
Center coordinates of site (lat/long in degree decimal format): Lat. **34.7279° N**, Long. **82.6125° W**.  
Universal Transverse Mercator: **NAD 83**

Name of nearest waterbody: **Pickens Creek**

Name of nearest Traditional Navigable Water (TNW) into which the aquatic resource flows: **Savannah**

Name of watershed or Hydrologic Unit Code (HUC): **Three & Twenty Creek**

Check if map/diagram of review area and/or potential jurisdictional areas is/are available upon request.

Check if other sites (e.g., offsite mitigation sites, disposal sites, etc...) are associated with this action and are recorded on a different JD form.

**D. REVIEW PERFORMED FOR SITE EVALUATION (CHECK ALL THAT APPLY):**

Office (Desk) Determination. Date: **13-March-2018**

Field Determination. Date(s):

**SECTION II: SUMMARY OF FINDINGS**

**A. RHA SECTION 10 DETERMINATION OF JURISDICTION.**

There **Are no** "navigable waters of the U.S." within Rivers and Harbors Act (RHA) jurisdiction (as defined by 33 CFR part 329) in the review area. [Required]

Waters subject to the ebb and flow of the tide.

Waters are presently used, or have been used in the past, or may be susceptible for use to transport interstate or foreign commerce.

Explain:

**B. CWA SECTION 404 DETERMINATION OF JURISDICTION.**

There **Are** "waters of the U.S." within Clean Water Act (CWA) jurisdiction (as defined by 33 CFR part 328) in the review area. [Required]

**1. Waters of the U.S.**

**a. Indicate presence of waters of U.S. in review area (check all that apply):<sup>1</sup>**

TNWs, including territorial seas

Wetlands adjacent to TNWs

Relatively permanent waters<sup>2</sup> (RPWs) that flow directly or indirectly into TNWs

Non-RPWs that flow directly or indirectly into TNWs

Wetlands directly abutting RPWs that flow directly or indirectly into TNWs

Wetlands adjacent to but not directly abutting RPWs that flow directly or indirectly into TNWs

Wetlands adjacent to non-RPWs that flow directly or indirectly into TNWs

Impoundments of jurisdictional waters

Isolated (interstate or intrastate) waters, including isolated wetlands

**b. Identify (estimate) size of waters of the U.S. in the review area:**

Non-wetland waters: **PRPW 1=317.3 linear feet, PRPW 2=773.8 linear feet, PRPW 3=179 linear feet, PRPW 4=3400.8 linear feet, and PRPW 5=72.8 linear feet:** width (ft) and/or acres.

Wetlands: **Wetland 1=3.23 acres and Wetland 2=3.74 acres.**

**c. Limits (boundaries) of jurisdiction based on: 1987 Delineation Manual, Established by OHWM., Pick List**

Elevation of established OHWM (if known):

**2. Non-regulated waters/wetlands (check if applicable):<sup>3</sup>**

Potentially jurisdictional waters and/or wetlands were assessed within the review area and determined to be not jurisdictional.

Explain:

<sup>1</sup> Boxes checked below shall be supported by completing the appropriate sections in Section III below.

<sup>2</sup> For purposes of this form, an RPW is defined as a tributary that is not a TNW and that typically flows year-round or has continuous flow at least "seasonally" (e.g., typically 3 months).

<sup>3</sup> Supporting documentation is presented in Section III.F.

SECTION III: CWA ANALYSIS

**A. TNWs AND WETLANDS ADJACENT TO TNWs**

The agencies will assert jurisdiction over TNWs and wetlands adjacent to TNWs. If the aquatic resource is a TNW, complete Section III.A.1 and Section III.D.1. only; if the aquatic resource is a wetland adjacent to a TNW, complete Sections III.A.1 and 2 and Section III.D.1.; otherwise, see Section III.B below.

**1. TNW**

Identify TNW: .

Summarize rationale supporting determination: .

**2. Wetland adjacent to TNW**

Summarize rationale supporting conclusion that wetland is "adjacent": .

**B. CHARACTERISTICS OF TRIBUTARY (THAT IS NOT A TNW) AND ITS ADJACENT WETLANDS (IF ANY):**

This section summarizes information regarding characteristics of the tributary and its adjacent wetlands, if any, and it helps determine whether or not the standards for jurisdiction established under *Rapanos* have been met.

The agencies will assert jurisdiction over non-navigable tributaries of TNWs where the tributaries are "relatively permanent waters" (RPWs), i.e. tributaries that typically flow year-round or have continuous flow at least seasonally (e.g., typically 3 months). A wetland that directly abuts an RPW is also jurisdictional. If the aquatic resource is not a TNW, but has year-round (perennial) flow, skip to Section III.D.2. If the aquatic resource is a wetland directly abutting a tributary with perennial flow, skip to Section III.D.4.

A wetland that is adjacent to but that does not directly abut an RPW requires a significant nexus evaluation. Corps districts and EPA regions will include in the record any available information that documents the existence of a significant nexus between a relatively permanent tributary that is not perennial (and its adjacent wetlands if any) and a traditional navigable water, even though a significant nexus finding is not required as a matter of law.

If the waterbody<sup>4</sup> is not an RPW, or a wetland directly abutting an RPW, a JD will require additional data to determine if the waterbody has a significant nexus with a TNW. If the tributary has adjacent wetlands, the significant nexus evaluation must consider the tributary in combination with all of its adjacent wetlands. This significant nexus evaluation that combines, for analytical purposes, the tributary and all of its adjacent wetlands is used whether the review area identified in the JD request is the tributary, or its adjacent wetlands, or both. If the JD covers a tributary with adjacent wetlands, complete Section III.B.1 for the tributary, Section III.B.2 for any onsite wetlands, and Section III.B.3 for all wetlands adjacent to that tributary, both onsite and offsite. The determination whether a significant nexus exists is determined in Section III.C below.

**1. Characteristics of non-TNWs that flow directly or indirectly into TNW**

**(i) General Area Conditions:**

Watershed size: **Pick List** ;

Drainage area: **Pick List**

Average annual rainfall: inches

Average annual snowfall: inches

**(ii) Physical Characteristics:**

**(a) Relationship with TNW:**

Tributary flows directly into TNW.

Tributary flows through **Pick List** tributaries before entering TNW.

Project waters are **Pick List** river miles from TNW.

Project waters are **Pick List** river miles from RPW.

Project waters are **Pick List** aerial (straight) miles from TNW.

Project waters are **Pick List** aerial (straight) miles from RPW.

Project waters cross or serve as state boundaries. Explain:

Identify flow route to TNW<sup>5</sup>:

Tributary stream order, if known:

<sup>4</sup> Note that the Instructional Guidebook contains additional information regarding swales, ditches, washes, and erosional features generally and in the arid West.

<sup>5</sup> Flow route can be described by identifying, e.g., tributary a, which flows through the review area, to flow into tributary b, which then flows into TNW.

(b) General Tributary Characteristics (check all that apply):

- Tributary is:**  Natural  
 Artificial (man-made). Explain:  
 Manipulated (man-altered). Explain:

**Tributary properties with respect to top of bank (estimate):**

Average width:       feet  
Average depth:       feet  
Average side slopes: **Pick List.**

**Primary tributary substrate composition (check all that apply):**

- |  |  |                                   |
|--|--|-----------------------------------|
| <input type="checkbox"/> Silts           | <input type="checkbox"/> Sands                     | <input type="checkbox"/> Concrete |
| <input type="checkbox"/> Cobbles         | <input type="checkbox"/> Gravel                    | <input type="checkbox"/> Muck     |
| <input type="checkbox"/> Bedrock         | <input type="checkbox"/> Vegetation. Type/% cover: |                                   |
| <input type="checkbox"/> Other. Explain: |  |                                   |

Tributary condition/stability [e.g., highly eroding, sloughing banks]. Explain:

Presence of run/riffle/pool complexes. Explain:

Tributary geometry: **Pick List.**

Tributary gradient (approximate average slope):       %

(c) Flow:

Tributary provides for: **Pick List**

Estimate average number of flow events in review area/year: **Pick List**

Describe flow regime:

Other information on duration and volume:

Surface flow is: **Pick List.** Characteristics:

Subsurface flow: **Pick List.** Explain findings:

Dye (or other) test performed:

Tributary has (check all that apply):

- |   |   |  |
|---|---|--|
| <input type="checkbox"/> Bed and banks  |   |  |
| <input type="checkbox"/> OHWM <sup>6</sup> (check all indicators that apply): |   |  |
| <input type="checkbox"/> clear, natural line impressed on the bank            | <input type="checkbox"/> the presence of litter and debris          |  |
| <input type="checkbox"/> changes in the character of soil                     | <input type="checkbox"/> destruction of terrestrial vegetation      |  |
| <input type="checkbox"/> shelving   | <input type="checkbox"/> the presence of wrack line                 |  |
| <input type="checkbox"/> vegetation matted down, bent, or absent              | <input type="checkbox"/> sediment sorting                           |  |
| <input type="checkbox"/> leaf litter disturbed or washed away                 | <input type="checkbox"/> scour                                      |  |
| <input type="checkbox"/> sediment deposition                                  | <input type="checkbox"/> multiple observed or predicted flow events |  |
| <input type="checkbox"/> water staining                                       | <input type="checkbox"/> abrupt change in plant community           |  |
| <input type="checkbox"/> other (list):  |   |  |
| <input type="checkbox"/> Discontinuous OHWM. <sup>7</sup> Explain:            |   |  |

If factors other than the OHWM were used to determine lateral extent of CWA jurisdiction (check all that apply):

- |  |  |
|--|--|
| <input type="checkbox"/> High Tide Line indicated by:              | <input type="checkbox"/> Mean High Water Mark indicated by:            |
| <input type="checkbox"/> oil or scum line along shore objects      | <input type="checkbox"/> survey to available datum;                    |
| <input type="checkbox"/> fine shell or debris deposits (foreshore) | <input type="checkbox"/> physical markings;                            |
| <input type="checkbox"/> physical markings/characteristics         | <input type="checkbox"/> vegetation lines/changes in vegetation types. |
| <input type="checkbox"/> tidal gauges                              |  |
| <input type="checkbox"/> other (list):                             |  |

(iii) **Chemical Characteristics:**

Characterize tributary (e.g., water color is clear, discolored, oily film; water quality; general watershed characteristics, etc.).

Explain:

Identify specific pollutants, if known:

<sup>6</sup>A natural or man-made discontinuity in the OHWM does not necessarily sever jurisdiction (e.g., where the stream temporarily flows underground, or where the OHWM has been removed by development or agricultural practices). Where there is a break in the OHWM that is unrelated to the waterbody's flow regime (e.g., flow over a rock outcrop or through a culvert), the agencies will look for indicators of flow above and below the break.

<sup>7</sup>Ibid.

(iv) **Biological Characteristics. Channel supports (check all that apply):**

- Riparian corridor. Characteristics (type, average width):
- Wetland fringe. Characteristics:
- Habitat for:
  - Federally Listed species. Explain findings:
  - Fish/spawn areas. Explain findings:
  - Other environmentally-sensitive species. Explain findings:
  - Aquatic/wildlife diversity. Explain findings:

2. **Characteristics of wetlands adjacent to non-TNW that flow directly or indirectly into TNW**

(i) **Physical Characteristics:**

(a) General Wetland Characteristics:

Properties:

Wetland size:            acres

Wetland type. Explain:

Wetland quality. Explain:

Project wetlands cross or serve as state boundaries. Explain:

(b) General Flow Relationship with Non-TNW:

Flow is: **Pick List**. Explain:

Surface flow is: **Pick List**

Characteristics:

Subsurface flow: **Pick List**. Explain findings:

Dye (or other) test performed:

(c) Wetland Adjacency Determination with Non-TNW:

Directly abutting

Not directly abutting

Discrete wetland hydrologic connection. Explain:

Ecological connection. Explain:

Separated by berm/barrier. Explain:

(d) Proximity (Relationship) to TNW

Project wetlands are **Pick List** river miles from TNW.

Project waters are **Pick List** aerial (straight) miles from TNW.

Flow is from: **Pick List**.

Estimate approximate location of wetland as within the **Pick List** floodplain.

(ii) **Chemical Characteristics:**

Characterize wetland system (e.g., water color is clear, brown, oil film on surface; water quality; general watershed characteristics; etc.). Explain:

Identify specific pollutants, if known:

(iii) **Biological Characteristics. Wetland supports (check all that apply):**

- Riparian buffer. Characteristics (type, average width):
- Vegetation type/percent cover. Explain:
- Habitat for:
  - Federally Listed species. Explain findings:
  - Fish/spawn areas. Explain findings:
  - Other environmentally-sensitive species. Explain findings:
  - Aquatic/wildlife diversity. Explain findings:

3. **Characteristics of all wetlands adjacent to the tributary (if any)**

All wetland(s) being considered in the cumulative analysis: **Pick List**

Approximately (            ) acres in total are being considered in the cumulative analysis.

For each wetland, specify the following:

<u>Directly abuts? (Y/N)</u>	<u>Size (in acres)</u>	<u>Directly abuts? (Y/N)</u>	<u>Size (in acres)</u>

Summarize overall biological, chemical and physical functions being performed:

### C. SIGNIFICANT NEXUS DETERMINATION

A significant nexus analysis will assess the flow characteristics and functions of the tributary itself and the functions performed by any wetlands adjacent to the tributary to determine if they significantly affect the chemical, physical, and biological integrity of a TNW. For each of the following situations, a significant nexus exists if the tributary, in combination with all of its adjacent wetlands, has more than a speculative or insubstantial effect on the chemical, physical and/or biological integrity of a TNW. Considerations when evaluating significant nexus include, but are not limited to the volume, duration, and frequency of the flow of water in the tributary and its proximity to a TNW, and the functions performed by the tributary and all its adjacent wetlands. It is not appropriate to determine significant nexus based solely on any specific threshold of distance (e.g. between a tributary and its adjacent wetland or between a tributary and the TNW). Similarly, the fact an adjacent wetland lies within or outside of a floodplain is not solely determinative of significant nexus.

Draw connections between the features documented and the effects on the TNW, as identified in the *Rapanos* Guidance and discussed in the Instructional Guidebook. Factors to consider include, for example:

- Does the tributary, in combination with its adjacent wetlands (if any), have the capacity to carry pollutants or flood waters to TNWs, or to reduce the amount of pollutants or flood waters reaching a TNW?
- Does the tributary, in combination with its adjacent wetlands (if any), provide habitat and lifecycle support functions for fish and other species, such as feeding, nesting, spawning, or rearing young for species that are present in the TNW?
- Does the tributary, in combination with its adjacent wetlands (if any), have the capacity to transfer nutrients and organic carbon that support downstream foodwebs?
- Does the tributary, in combination with its adjacent wetlands (if any), have other relationships to the physical, chemical, or biological integrity of the TNW?

**Note: the above list of considerations is not inclusive and other functions observed or known to occur should be documented below:**

1. **Significant nexus findings for non-RPW that has no adjacent wetlands and flows directly or indirectly into TNWs.** Explain findings of presence or absence of significant nexus below, based on the tributary itself, then go to Section III.D:
2. **Significant nexus findings for non-RPW and its adjacent wetlands, where the non-RPW flows directly or indirectly into TNWs.** Explain findings of presence or absence of significant nexus below, based on the tributary in combination with all of its adjacent wetlands, then go to Section III.D:
3. **Significant nexus findings for wetlands adjacent to an RPW but that do not directly abut the RPW.** Explain findings of presence or absence of significant nexus below, based on the tributary in combination with all of its adjacent wetlands, then go to Section III.D:

**Documentation for the Record only: Significant nexus findings for seasonal RPWs and/or wetlands abutting seasonal RPWs:**

### D. DETERMINATIONS OF JURISDICTIONAL FINDINGS. THE SUBJECT WATERS/WETLANDS ARE (CHECK ALL THAT APPLY):

1. **TNWs and Adjacent Wetlands.** Check all that apply and provide size estimates in review area:
  - TNWs: linear feet width (ft), Or, acres.
  - Wetlands adjacent to TNWs: acres.
2. **RPWs that flow directly or indirectly into TNWs.**
  - Tributaries of TNWs where tributaries typically flow year-round are jurisdictional. Provide data and rationale indicating that tributary is perennial: **PRPW 4 (Pickens Creek) is shown as a named blue line on the topo and as perennial on the soil**

map. PRPW 1, PRPW 2, PRPW 3, and PRPW 5 are shown as intermittent on the soil map and as drainage features on the topo map. All PRPWs were observed flowing at the time of flagging, have distinct channels, and strong OHWMs. Available data led this office to conclude the tributaries have a perennial flow regime.

- Tributaries of TNW where tributaries have continuous flow "seasonally" (e.g., typically three months each year) are jurisdictional. Data supporting this conclusion is provided at Section III.B. Provide rationale indicating that tributary flows seasonally:

Provide estimates for jurisdictional waters in the review area (check all that apply):

- Tributary waters: **PRPW 1=317.3 linear feet, PRPW 2=773.8 linear feet, PRPW 3=179 linear feet, PRPW 4=3400.8 linear feet, and PRPW 5=72.8 linear feet** width (ft).  
 Other non-wetland waters: acres.  
Identify type(s) of waters:

**3. Non-RPWs<sup>8</sup> that flow directly or indirectly into TNWs.**

- Waterbody that is not a TNW or an RPW, but flows directly or indirectly into a TNW, and it has a significant nexus with a TNW is jurisdictional. Data supporting this conclusion is provided at Section III.C.

Provide estimates for jurisdictional waters within the review area (check all that apply):

- Tributary waters: linear feet width (ft).  
 Other non-wetland waters: acres.  
Identify type(s) of waters:

**4. Wetlands directly abutting an RPW that flow directly or indirectly into TNWs.**

- Wetlands directly abut RPW and thus are jurisdictional as adjacent wetlands.  
 Wetlands directly abutting an RPW where tributaries typically flow year-round. Provide data and rationale indicating that tributary is perennial in Section III.D.2, above. Provide rationale indicating that wetland is directly abutting an RPW: **The wetlands have a continuous surface connection with on-site perennial RPWs.**  
 Wetlands directly abutting an RPW where tributaries typically flow "seasonally." Provide data indicating that tributary is seasonal in Section III.B and rationale in Section III.D.2, above. Provide rationale indicating that wetland is directly abutting an RPW:

Provide acreage estimates for jurisdictional wetlands in the review area: **Wetland 1=3.23 acres and Wetland 2=3.74 acres.**

**5. Wetlands adjacent to but not directly abutting an RPW that flow directly or indirectly into TNWs.**

- Wetlands that do not directly abut an RPW, but when considered in combination with the tributary to which they are adjacent and with similarly situated adjacent wetlands, have a significant nexus with a TNW are jurisdictional. Data supporting this conclusion is provided at Section III.C.

Provide acreage estimates for jurisdictional wetlands in the review area: acres.

**6. Wetlands adjacent to non-RPWs that flow directly or indirectly into TNWs.**

- Wetlands adjacent to such waters, and have when considered in combination with the tributary to which they are adjacent and with similarly situated adjacent wetlands, have a significant nexus with a TNW are jurisdictional. Data supporting this conclusion is provided at Section III.C.

Provide estimates for jurisdictional wetlands in the review area: acres.

**7. Impoundments of jurisdictional waters.<sup>9</sup>**

As a general rule, the impoundment of a jurisdictional tributary remains jurisdictional.

- Demonstrate that impoundment was created from "waters of the U.S.," or  
 Demonstrate that water meets the criteria for one of the categories presented above (1-6), or  
 Demonstrate that water is isolated with a nexus to commerce (see E below).

**Explain:**

**E. ISOLATED [INTERSTATE OR INTRA-STATE] WATERS, INCLUDING ISOLATED WETLANDS, THE USE, DEGRADATION OR DESTRUCTION OF WHICH COULD AFFECT INTERSTATE COMMERCE, INCLUDING ANY SUCH WATERS (CHECK ALL THAT APPLY):<sup>10</sup>**

- which are or could be used by interstate or foreign travelers for recreational or other purposes.

<sup>8</sup>See Footnote # 3.

<sup>9</sup> To complete the analysis refer to the key in Section III.D.6 of the Instructional Guidebook.

<sup>10</sup> Prior to asserting or declining CWA jurisdiction based solely on this category, Corps Districts will elevate the action to Corps and EPA HQ for review consistent with the process described in the Corps/EPA Memorandum Regarding CWA Act Jurisdiction Following Rapanos.

- from which fish or shellfish are or could be taken and sold in interstate or foreign commerce.
- which are or could be used for industrial purposes by industries in interstate commerce.
- Interstate isolated waters. Explain:
- Other factors. Explain:

**Identify water body and summarize rationale supporting determination:**

Provide estimates for jurisdictional waters in the review area (check all that apply):

- Tributary waters: linear feet width (ft).
- Other non-wetland waters: acres.
- Identify type(s) of waters:
- Wetlands: acres.

**F. NON-JURISDICTIONAL WATERS, INCLUDING WETLANDS (CHECK ALL THAT APPLY):**

- If potential wetlands were assessed within the review area, these areas did not meet the criteria in the 1987 Corps of Engineers Wetland Delineation Manual and/or appropriate Regional Supplements.
- Review area included isolated waters with no substantial nexus to interstate (or foreign) commerce.
  - Prior to the Jan 2001 Supreme Court decision in "SWANCC," the review area would have been regulated based solely on the "Migratory Bird Rule" (MBR).
- Waters do not meet the "Significant Nexus" standard, where such a finding is required for jurisdiction. Explain:
- Other: (explain, if not covered above):

Provide acreage estimates for non-jurisdictional waters in the review area, where the sole potential basis of jurisdiction is the MBR factors (i.e., presence of migratory birds, presence of endangered species, use of water for irrigated agriculture), using best professional judgment (check all that apply):

- Non-wetland waters (i.e., rivers, streams): linear feet width (ft).
- Lakes/ponds: acres.
- Other non-wetland waters: acres. List type of aquatic resource:
- Wetlands: acres.

Provide acreage estimates for non-jurisdictional waters in the review area that do not meet the "Significant Nexus" standard, where such a finding is required for jurisdiction (check all that apply):

- Non-wetland waters (i.e., rivers, streams): linear feet, width (ft).
- Lakes/ponds: acres.
- Other non-wetland waters: acres. List type of aquatic resource:
- Wetlands: acres.

**SECTION IV: DATA SOURCES.**

**A. SUPPORTING DATA. Data reviewed for JD (check all that apply - checked items shall be included in case file and, where checked and requested, appropriately reference sources below):**

- Maps, plans, plots or plat submitted by or on behalf of the applicant/consultant: **Froehling & Roberston, Inc.**
- Data sheets prepared/submitted by or on behalf of the applicant/consultant.
  - Office concurs with data sheets/delineation report. This office agrees with the conclusions of the submitted data sheets.
  - Office does not concur with data sheets/delineation report.
- Data sheets prepared by the Corps:
- Corps navigable waters' study: **1977 Navigability Study.**
- U.S. Geological Survey Hydrologic Atlas: **HA 730-G, 1990.**
  - USGS NHD data.
  - USGS 8 and 12 digit HUC maps. Three & Twenty Creek 03060101-07
- U.S. Geological Survey map(s). Cite scale & quad name: **1:24,000 Piercetown.**
- USDA Natural Resources Conservation Service Soil Survey. Citation: **Anderson County Soil Map 7, Madison, Cartecay-Chewacla.**
- National wetlands inventory map(s). Cite name: **USFWS Wetland Map.**
- State/Local wetland inventory map(s):
- FEMA/FIRM maps:
- 100-year Floodplain Elevation is: (National Geodectic Vertical Datum of 1929)
- Photographs:  Aerial (Name & Date): **Google Image dated October 30, 2017.**
  - or  Other (Name & Date): **Photos 1-21 of 21 taken by F&R dated January 24, 2017.**
- Previous determination(s). File no. and date of response letter: **SAC-2008-00559 May 13, 2008.**
- Applicable/supporting case law:
- Applicable/supporting scientific literature:
- Other information (please specify):

**B. ADDITIONAL COMMENTS TO SUPPORT JD: The aquatic resources on-site include 5 perennial RPWs and 2 wetlands abutting perennial RPWs. Based on guidance provided, perennial RPWs and wetlands abutting perennial RPWs are jurisdictional under the Clean Water Act and Waters of the U.S.**



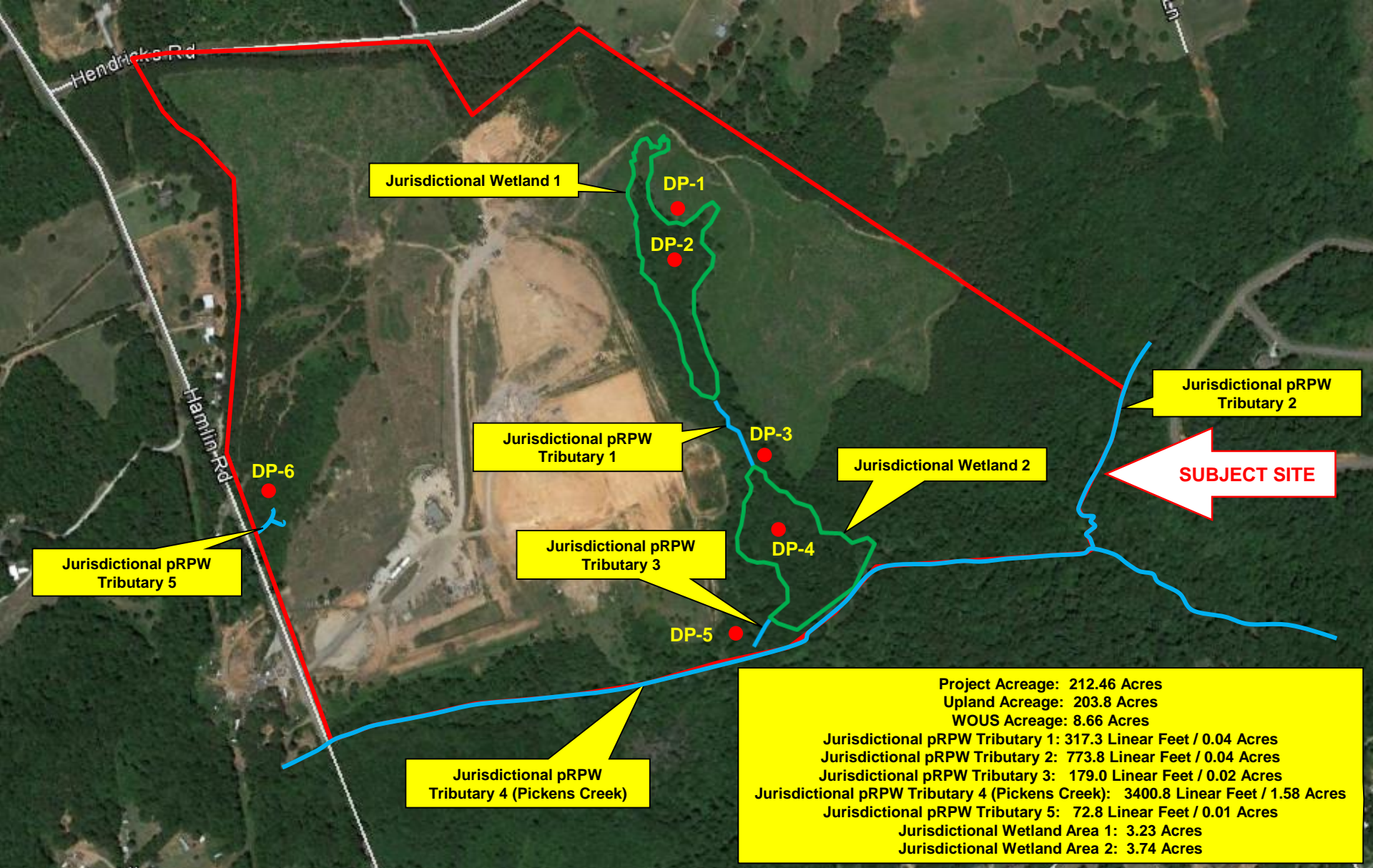

### WATERS OF THE US SKETCH



**FROEHLING & ROBERTSON, INC.**  
 ENGINEERING • ENVIRONMENTAL • GEOTECHNICAL  
 18 Woods Lake Road  
 Greenville, South Carolina | USA  
 T 864.271.2840 | F 864.271.8124

Client:	Alliance Consulting Engineers, Inc.	
Project:	Greenpointe Landfill Expansion JWD	
Location:	500 Hamlin Road, Easley, Anderson County, SC	
F&R Project No:	65U-0176	
Source:	Anderson County GIS & F&R	
Date: January 30, 2017	Scale: Not Shown	Figure 6 of 7

## NOTIFICATION OF ADMINISTRATIVE APPEAL OPTIONS AND PROCESS AND REQUEST FOR APPEAL

Applicant:	File Number:	Date:
Attached is:		See Section below
	INITIAL PROFFERED PERMIT (Standard Permit or Letter of permission)	A
	PROFFERED PERMIT (Standard Permit or Letter of permission)	B
	PERMIT DENIAL	C
	APPROVED JURISDICTIONAL DETERMINATION	D
	PRELIMINARY JURISDICTIONAL DETERMINATION	E

**SECTION I - The following identifies your rights and options regarding an administrative appeal of the above decision. Additional information may be found at <http://usace.army.mil/inet/functions/cw/cecwo/reg> or Corps regulations at 33 CFR Part 331.**

**A: INITIAL PROFFERED PERMIT:** You may accept or object to the permit.

- **ACCEPT:** If you received a Standard Permit, you may sign the permit document and return it to the district engineer for final authorization. If you received a Letter of Permission (LOP), you may accept the LOP and your work is authorized. Your signature on the Standard Permit or acceptance of the LOP means that you accept the permit in its entirety, and waive all rights to appeal the permit, including its terms and conditions, and approved jurisdictional determinations associated with the permit.
- **OBJECT:** If you object to the permit (Standard or LOP) because of certain terms and conditions therein, you may request that the permit be modified accordingly. You must complete Section II of this form and return the form to the district engineer. Your objections must be received by the district engineer within 60 days of the date of this notice, or you will forfeit your right to appeal the permit in the future. Upon receipt of your letter, the district engineer will evaluate your objections and may: (a) modify the permit to address all of your concerns, (b) modify the permit to address some of your objections, or (c) not modify the permit having determined that the permit should be issued as previously written. After evaluating your objections, the district engineer will send you a proffered permit for your reconsideration, as indicated in Section B below.

**B: PROFFERED PERMIT:** You may accept or appeal the permit

- **ACCEPT:** If you received a Standard Permit, you may sign the permit document and return it to the district engineer for final authorization. If you received a Letter of Permission (LOP), you may accept the LOP and your work is authorized. Your signature on the Standard Permit or acceptance of the LOP means that you accept the permit in its entirety, and waive all rights to appeal the permit, including its terms and conditions, and approved jurisdictional determinations associated with the permit.
- **APPEAL:** If you choose to decline the proffered permit (Standard or LOP) because of certain terms and conditions therein, you may appeal the declined permit under the Corps of Engineers Administrative Appeal Process by completing Section II of this form and sending the form to the division engineer. This form must be received by the division engineer within 60 days of the date of this notice.

**C: PERMIT DENIAL:** You may appeal the denial of a permit under the Corps of Engineers Administrative Appeal Process by completing Section II of this form and sending the form to the division engineer. This form must be received by the division engineer within 60 days of the date of this notice.

**D: APPROVED JURISDICTIONAL DETERMINATION:** You may accept or appeal the approved JD or provide new information.

- **ACCEPT:** You do not need to notify the Corps to accept an approved JD. Failure to notify the Corps within 60 days of the date of this notice, means that you accept the approved JD in its entirety, and waive all rights to appeal the approved JD.
- **APPEAL:** If you disagree with the approved JD, you may appeal the approved JD under the Corps of Engineers Administrative Appeal Process by completing Section II of this form and sending the form to the Division Engineer, South Atlantic Division, 60 Forsyth St, SW, Atlanta, GA 30308-8801. This form must be received by the Division Engineer within 60 days of the date of this notice.

**E: PRELIMINARY JURISDICTIONAL DETERMINATION:** You do not need to respond to the Corps regarding the preliminary JD. The Preliminary JD **is not appealable**. If you wish, you may request an approved JD (which may be appealed), by contacting the Corps district for further instruction. Also you may provide new information for further consideration by the Corps to reevaluate the JD.

**SECTION II - REQUEST FOR APPEAL or OBJECTIONS TO AN INITIAL PROFFERED PERMIT**

**REASONS FOR APPEAL OR OBJECTIONS:** (Describe your reasons for appealing the decision or your objections to an initial proffered permit in clear concise statements. You may attach additional information to this form to clarify where your reasons or objections are addressed in the administrative record.)

**ADDITIONAL INFORMATION:** The appeal is limited to a review of the administrative record, the Corps memorandum for the record of the appeal conference or meeting, and any supplemental information that the review officer has determined is needed to clarify the administrative record. Neither the appellant nor the Corps may add new information or analyses to the record. However, you may provide additional information to clarify the location of information that is already in the administrative record.

**POINT OF CONTACT FOR QUESTIONS OR INFORMATION:**

If you have questions regarding this decision and/or the appeal process you may contact the Corps biologist who signed the letter to which this notification is attached. The name and telephone number of this person is given at the end of the letter.

If you only have questions regarding the appeal process you may also contact: Jason W. Steele  
Administrative Appeals Review Officer  
USACE South Atlantic Division  
60 Forsyth St, SW  
Atlanta, GA 30308-8801  
(404) 562-5137

**RIGHT OF ENTRY:** Your signature below grants the right of entry to Corps of Engineers personnel, and any government consultants, to conduct investigations of the project site during the course of the appeal process. You will be provided a 15 day notice of any site investigation, and will have the opportunity to participate in all site investigations.

\_\_\_\_\_  
Signature of appellant or agent.

Date:

Telephone number:



January 18, 2018

**CERTIFIED MAIL**

Wasteco, Inc.  
Attn: Radford Jenkins, Vice President  
PO Box 8028  
Greenville, SC 29604

**Final Decision**  
RE: Landfill Determination Request for Expansion dated August 15, 2017  
Greenpointe Class 2 Landfill – Permit # LF2-00001  
Anderson County

*This decision applies to the first phase of the landfill permitting process, which deals with need, consistency, zoning, and certain buffers.*

Dear Mr. Jenkins:

The Department issued its draft determinations of need and consistency on December 6, 2017, for the expansion of the existing landfill. In addition, the Department noticed these draft determinations in *The Greenville News* newspaper on Wednesday December 6, 2017. During the comment period, no comments were received. After careful review of all submittals, the Department's decision is that the proposed expansion of the Greenpointe Class 2 Landfill satisfies the requirements found in Regulation 61-107.19, *Solid Waste Management: Solid Waste Landfills and Structural Fill*, Part I, Section D.1 and Regulation 61-107.17. You may proceed with submitting the technical application for a Class 2 Landfill permit.

This decision becomes the final agency decision fifteen (15) days from the date of the certified mailing of the decision unless a written request for final review is filed with the Department. This decision may be appealed by complying with the requirements described in the attached Notice of Appeal Procedure, provided as a courtesy by the Department.

Notice of this decision will be printed in the Thursday, January 18, 2018, edition of *The Greenville News*. If you have any questions regarding this decision, please contact Juli Blalock at (803) 898-1356.

Sincerely,

A handwritten signature in blue ink that reads "Joan F. Litton".

Joan F. Litton, Director  
Division of Mining and Solid Waste Management  
Bureau of Land and Waste Management

JFL/jtk

enc: Public Notice

cc: Marty Lindler, Manager and Jessica McLain – SW Compliance  
Sabrina Prince – Upstate EA Region, Anderson Office  
Emily Palamara, Alliance Engineering – [epalamara@alliancece.com](mailto:epalamara@alliancece.com)  
Radford Jenkins, Wasteco – [radford@wastecoinc.com](mailto:radford@wastecoinc.com)  
Russell Burns, Anderson County Administrator – [rburns@andersoncountysc.org](mailto:rburns@andersoncountysc.org)  
Bureau File #21126

DEPARTMENT OF HEALTH AND ENVIRONMENTAL CONTROL  
Notice of Department Decision

GREENPOINTE CLASS 2 LANDFILL  
HAMLIN ROAD  
EASLEY, SOUTH CAROLINA

This decision applies to the first phase of the landfill permitting process, which deals with need, consistency, zoning, and certain buffers.

Pursuant to Regulation 61-107.19, *Solid Waste Management: Solid Waste Landfills and Structural Fill*, the public is hereby notified that the South Carolina Department of Health and Environmental Control's (the Department's) Division of Mining and Solid Waste Management has made a Department Decision regarding the determination of need and consistency for a Class 2 Landfill at the above-referenced location. The Department Decision is that the proposed expansion of the Greenpointe Class 2 Landfill meets the requirements set forth in Part I, Section D.1 of Regulation 61-107.19.

This decision becomes the final agency decision fifteen (15) days from the date of the certified mailing (January 18, 2018) of the decision unless a written request for final review is filed with the Department. This decision may be appealed by complying with the procedures for requesting a Final Review before the Board of Health and Environmental Control (the Board) at:

<http://www.scdhec.gov/Agency/BoardofDirectors/GuidetoBoardReview/>

If anyone has questions regarding the Department Decision on the Greenpointe Class 2 Landfill Expansion and/or the procedures for requesting a final review, contact Juli E. Blalock, Manager of the Solid Waste Permitting and Monitoring Section, at (803) 898-1356.



August 15, 2017

Mr. Justin Koon, Associate Engineer  
Division of Mining and Solid Waste Management  
Bureau of Land & Waste Management  
SC Department of Health and Environmental Control  
2600 Bull Street  
Columbia, South Carolina 29201

Re: Demonstration-of-Need Request for the  
Expansion of the Greenpoint Landfill in  
Unincorporated Anderson County,  
South Carolina  
Permit No. LF2-001

Dear Mr. Koon:

Wasteco, Inc., in conjunction with Alliance Consulting Engineers, Inc. would like to formally request a Demonstration-of-Need determination from the South Carolina Department of Health and Environmental Control (SCDHEC) to permit the Expansion of the existing Greenpoint Class Two Construction and Demolition Debris (C&D) Landfill along Hamlin Road in Anderson County, South Carolina in compliance with SCDHEC Regulation *R.61-107.17 Demonstration-of-Need* and *R.61-107.19 Solid Waste Landfills and Structural Fill* which became effective June 26, 2009 and May 23, 2008, respectively.

I. DEMONSTRATION-OF-NEED REQUEST REQUIREMENTS

A. Facility Name

- Greenpoint Landfill

B. Applicant Contact Information

- Owner/Operator: Wasteco, Inc.
- Contact: Mr. Radford Jenkins, Vice President
- Address: Post Office Box 8028  
Greenville, South Carolina 29604
- Phone: (864) 233-0100
- Facsimile: (864) 442-6752

C. Facility Information

- Geographical Coordinates:
  - 34°43'40.14"N Latitude and 82°36'47.57"W Longitude
  - Coordinates for the Class Two C&D Landfill Expansion were determined using a reference point centrally located within the developed portion of the Landfill facility.

Alliance Consulting Engineers, Inc.

124 Verdae Blvd., Bonaventure II, Suite 505 Greenville, SC 29607-3843 Phone 864 284-1740 Fax 864 284-1741 www.allianceCE.com

Bluffton, SC | Charleston, SC | Charlotte, NC | Columbia, SC | Greenville, SC

Mr. Justin Koon, Associate Engineer  
SC Department of Health and Environmental Control  
August 15, 2017 - Page 2 of 2

- Location Description:  
The Greenpointe Landfill is located approximately one (1) mile north of Old Greenville Highway Extension (SC Highway 88) along Hamlin Road near the City of Easley, South Carolina.
- Facility Type:
  - Active Class Two Construction and Demolition Debris Landfill
- Annual Disposal Rate:
  - Annual Average Disposal: 35,000 ton/year
  - Permitted Disposal Rate: 57,000 ton/year
- Host County:
  - Anderson County, South Carolina

We trust that this information is to your satisfaction and look forward to your approval. If you have any questions or comments, please do not hesitate to contact our office at (803) 779-2078.

Very truly yours,  
ALLIANCE CONSULTING ENGINEERS, INC.



Mr. Daniel A. Esteban, P.E.  
Regional Manager

Enclosures

cc: Mr. David Oberly, SC Department of Health and Environmental Control w/ enclosures  
Mr. Radford Jenkins, Wasteco, Inc. w/ enclosures  
Mr. Deepal S. Eliatamby, P.E., SCCED, Alliance Consulting Engineers, Inc.  
Mr. Kyle M. Clampitt, P.E., Alliance Consulting Engineers, Inc.  
Ms. Emily N. Palamara, LEED Green Associate, Alliance Consulting Engineers, Inc.



Welcome to: **ACPASS**  
 "Anderson County Public Access System and Services"

[REAL PROPERTY](#) / [VEHICLE TAX](#) / [PROPERTY TAX](#) / [COURTS](#) / [PERMITS](#) / [FORMS](#)

Main=>Real Property=>Property Search=>Select Record=>Property Detail

Property Record Detail								
<a href="#">View Taxes</a>			<a href="#">View Parcel</a>					
TAXMAP NO.			OLD TAMAP NO.			PARENT TMS NO.		
138-00-04-013-000						138-00-04-002		
Owner Information								
Current Owner					Previous Owner			
Name	BJ2 LLC				Name	HILL CHARLES K		
Address	504 CRESCENT AVE				Address	504 CRESCENT AVE		
City, State	GREENVILLE SC				City, State	GREENVILLE SC		
Zip	29601-0000				Zip	29601-0000		
Sales Information								
Date	Book#	Page#	Price	Purchaser				
8/22/2008	8826	00098	\$ 1.00	BJ2 LLC				
8/21/2008	8815	00311	\$ 166,400.00	HILL CHARLES K				
12/12/2006	7754	194	\$ 384,036.00	ELLIS JEFFREY L				
11/30/2006	7725	193		YOUNG RUTH T				
Property Information								
Subdivision					Tax District	103		
Physical Address					Market Value	135,660		
M/H					Prior Value	159,600		
					Tax Value	135,660		
					Exempt			
Legal Description								
Legal Desc 1	CP S 1794/7B							
Legal Desc 2	F000 D000 PP S 1657/10							
Legal Desc 3	PT TR C HENDRICKS RD 15.96 AC							
Assessment Totals								
YEAR	ACRES	LOTS	LAND ASMT	#BLDG	BLDG ASMT	TOT ASMT	RAT CD	RC
2016	15.96		80			80	A	
2015	15.96		80			80	A	
2014	15.96		80			80	A	
2013	15.96		80			80	A	01

Legal Disclaimer - HELP - Privacy Disclaimer

COPYRIGHT 2002, ANDERSON COUNTY SC





Welcome to: **ACPASS**  
 "Anderson County Public Access System and Services"

[REAL PROPERTY](#) / [VEHICLE TAX](#) / [PROPERTY TAX](#) / [COURTS](#) / [PERMITS](#) / [FORMS](#)

Main=>Real Property=>Property Search=>Select Record=>Property Detail

Property Record Detail								
<a href="#">View Taxes</a>			<a href="#">View Parcel</a>					
TAXMAP NO.			OLD TAMAP NO.			PARENT TMS NO.		
<b>164-00-02-036-000</b>								
Owner Information								
Current Owner					Previous Owner			
Name	BJ2 LLC				Name	JENKINS ROBERT R		
Address	PO BOX 8028				Address	PO BOX 8028		
City, State	GREENVILLE SC				City, State	GREENVILLE SC		
Zip	29604-0000				Zip	29604-0000		
Sales Information								
Date	Book#	Page#	Price	Purchaser				
8/04/2009	9287	00110	\$ 1.00	BJ2 LLC				
9/14/2005	6955	00261	\$ 1,018,316.00	JENKINS ROBERT R				
5/31/2001	4205	187	\$ 330,000.00	VANESKY GARY				
3/02/1959	11S	121		HUNT ISABEL RUTH ALLGOOD				
Property Information								
Subdivision					Tax District	103		
Physical Address	500 HAMLIN RD				Market Value	1,018,220		
M/H					Prior Value	508,041		
					Tax Value	556,408		
					Exempt			
Legal Description								
Legal Desc 1	CP S 1228/4+5							
Legal Desc 2	F000 D000							
Legal Desc 3	HAMLIN RD 195.83 AC							
Assessment Totals								
YEAR	ACRES	LOTS	LAND ASMT	#BLDG	BLDG ASMT	TOT ASMT	RAT CD	RC
2016	195.83		11430	3	2340	13770	A C	
2015	195.83		11430	3	2340	13770	A C	
2014	195.83		11430	3	2340	13770	A C	
2013	195.83		11430	3	2340	13770	A C	03

Legal Disclaimer - HELP - Privacy Disclaimer

COPYRIGHT 2002, ANDERSON COUNTY SC

<b>Greenpointe Landfill Adjoining Properties</b>		
<b>TMS#</b>	<b>Owner</b>	<b>Address</b>
138-00-05-004	Debra Lynn Sheridan Life Estate	818 Hamlin Road, Easley, South Carolina 29642
138-00-05-003	Timothy Allen Moore	828 Hamlin Road, Easley, South Carolina 29642
138-00-05-001	Timothy Allen Moore	828 Hamlin Road, Easley, South Carolina 29642
138-00-05-002	Timothy Allen Moore	828 Hamlin Road, Easley, South Carolina 29642
138-00-04-016	Thomas T. Gaede & Lauren M. McNally	778 Hendricks Road, Easley, South Carolina 29642
138-00-04-015	Douglas J. Martin & Anne H. Martin	118 Alpen Road, Easley, South Carolina 29642
138-00-04-010	Brian Speedy & Michelle Speedy	858 Hamlin Road, Easley, South Carolina 29642
138-00-04-014	Brett F. Stansell & Angela L. Stansell	102 Indigo Lane, Easley, South Carolina 29642
164-00-02-037	Tony M. Todd & Jean Todd	606 Hendricks Road, Easley, South Carolina 29642
164-00-02-038	Jamie S. Nix	544 Hendricks Road, Easley, South Carolina 29642
164-00-02-001	Curtis Jackson, Jr.	104 Oldfield Court, Lexington, South Carolina 29072
164-00-02-061	Michelle Jackson	309 Delaine Woods Drive, Irmo, South Carolina 29063
164-00-02-060	Lenora Jackson Simpson	125 A Karen Court, Bridgeport, Connecticut 06606
164-00-02-059	John Jackson	541 Mildred Street, Anderson, South Carolina 29621

### Greenpointe Landfill Adjoining Properties

TMS#	Owner	Address
164-00-02-058	Jackson Aquillious	100 Acquillions Lane, Easley, South Carolina 29642
164-00-02-057	Curtis Jackson, Jr.	104 Old Field Court, Lexington, South Carolina 29072
164-05-01-167	Avendell Homeowners Association, Inc.	Post Office Box 1827, Greenville, South Carolina 29602
164-00-02-034	Walter R. Meece & Katie S. Meece	406 Wilderness Trail, Liberty, South Carolina 29657
164-00-02-035	Donne H. Crawford	408 Wilderness Trail, Liberty, South Carolina 29657
165-00-04-054	James W. Cruse, Jr.	430B Wilderness Trail, Liberty, South Carolina 29657
165-00-04-053	James W. Cruse, Jr.	430B Wilderness Trail, Liberty, South Carolina 29657
165-00-04-052	Jerry R. Turner & Carter D. Turner	1730 Geer Highway, Travelers Rest, South Carolina 29690
165-00-04-051	Becky Jeanette Halbert	504 Wilderness Trail, Liberty, South Carolina 29657
165-00-04-011	Morris R. Smith & Morine N. Smith	141 Lydia Drive, Liberty, South Carolina 29657
165-00-04-010	Stanley R. Gallimore & Delores S. Gallimore	142 Lydia Drive, Liberty, South Carolina 29657
165-00-04-001	Sherry Faye Carter	410 Hamlin Road, Liberty, South Carolina 29657
138-00-03-048	Lonnie Allen Suddeth	415 Hamlin Road, Liberty, South Carolina 29657
138-00-03-008	Garth B. Davis & Sherry D. Alexander	503 Hamlin Road, Easley, South Carolina 29642
138-00-03-007	Smith Carvery Ann W. & A Michael Smith	817 Hamlin Road, Easley, South Carolina 29642



January 18, 2018

**CERTIFIED MAIL**

Wasteco, Inc.  
Attn: Radford Jenkins, Vice President  
PO Box 8028  
Greenville, SC 29604

**Final Decision**  
RE: Landfill Determination Request for Expansion dated August 15, 2017  
Greenpointe Class 2 Landfill – Permit # LF2-00001  
Anderson County

*This decision applies to the first phase of the landfill permitting process, which deals with need, consistency, zoning, and certain buffers.*

Dear Mr. Jenkins:

The Department issued its draft determinations of need and consistency on December 6, 2017, for the expansion of the existing landfill. In addition, the Department noticed these draft determinations in *The Greenville News* newspaper on Wednesday December 6, 2017. During the comment period, no comments were received. After careful review of all submittals, the Department's decision is that the proposed expansion of the Greenpointe Class 2 Landfill satisfies the requirements found in Regulation 61-107.19, *Solid Waste Management: Solid Waste Landfills and Structural Fill*, Part I, Section D.1 and Regulation 61-107.17. You may proceed with submitting the technical application for a Class 2 Landfill permit.

This decision becomes the final agency decision fifteen (15) days from the date of the certified mailing of the decision unless a written request for final review is filed with the Department. This decision may be appealed by complying with the requirements described in the attached Notice of Appeal Procedure, provided as a courtesy by the Department.

Notice of this decision will be printed in the Thursday, January 18, 2018, edition of *The Greenville News*. If you have any questions regarding this decision, please contact Juli Blalock at (803) 898-1356.

Sincerely,

A handwritten signature in blue ink that reads "Joan F. Litton".

Joan F. Litton, Director  
Division of Mining and Solid Waste Management  
Bureau of Land and Waste Management

JFL/jtk

enc: Public Notice

cc: Marty Lindler, Manager and Jessica McLain – SW Compliance  
Sabrina Prince – Upstate EA Region, Anderson Office  
Emily Palamara, Alliance Engineering – [epalamara@alliancece.com](mailto:epalamara@alliancece.com)  
Radford Jenkins, Wasteco – [radford@wastecoinc.com](mailto:radford@wastecoinc.com)  
Russell Burns, Anderson County Administrator – [rburns@andersoncountysc.org](mailto:rburns@andersoncountysc.org)  
Bureau File #21126

DEPARTMENT OF HEALTH AND ENVIRONMENTAL CONTROL  
Notice of Department Decision

GREENPOINTE CLASS 2 LANDFILL  
HAMLIN ROAD  
EASLEY, SOUTH CAROLINA

This decision applies to the first phase of the landfill permitting process, which deals with need, consistency, zoning, and certain buffers.

Pursuant to Regulation 61-107.19, *Solid Waste Management: Solid Waste Landfills and Structural Fill*, the public is hereby notified that the South Carolina Department of Health and Environmental Control's (the Department's) Division of Mining and Solid Waste Management has made a Department Decision regarding the determination of need and consistency for a Class 2 Landfill at the above-referenced location. The Department Decision is that the proposed expansion of the Greenpointe Class 2 Landfill meets the requirements set forth in Part I, Section D.1 of Regulation 61-107.19.

This decision becomes the final agency decision fifteen (15) days from the date of the certified mailing (January 18, 2018) of the decision unless a written request for final review is filed with the Department. This decision may be appealed by complying with the procedures for requesting a Final Review before the Board of Health and Environmental Control (the Board) at:

<http://www.scdhec.gov/Agency/BoardofDirectors/GuidetoBoardReview/>

If anyone has questions regarding the Department Decision on the Greenpointe Class 2 Landfill Expansion and/or the procedures for requesting a final review, contact Juli E. Blalock, Manager of the Solid Waste Permitting and Monitoring Section, at (803) 898-1356.



August 15, 2017

Mr. Justin Koon, Associate Engineer  
Division of Mining and Solid Waste Management  
Bureau of Land & Waste Management  
SC Department of Health and Environmental Control  
2600 Bull Street  
Columbia, South Carolina 29201

Re: Demonstration-of-Need Request for the  
Expansion of the Greenpoint Landfill in  
Unincorporated Anderson County,  
South Carolina  
Permit No. LF2-001

Dear Mr. Koon:

Wasteco, Inc., in conjunction with Alliance Consulting Engineers, Inc. would like to formally request a Demonstration-of-Need determination from the South Carolina Department of Health and Environmental Control (SCDHEC) to permit the Expansion of the existing Greenpoint Class Two Construction and Demolition Debris (C&D) Landfill along Hamlin Road in Anderson County, South Carolina in compliance with SCDHEC Regulation *R.61-107.17 Demonstration-of-Need* and *R.61-107.19 Solid Waste Landfills and Structural Fill* which became effective June 26, 2009 and May 23, 2008, respectively.

I. DEMONSTRATION-OF-NEED REQUEST REQUIREMENTS

A. Facility Name

- Greenpoint Landfill

B. Applicant Contact Information

- Owner/Operator: Wasteco, Inc.
- Contact: Mr. Radford Jenkins, Vice President
- Address: Post Office Box 8028  
Greenville, South Carolina 29604
- Phone: (864) 233-0100
- Facsimile: (864) 442-6752

C. Facility Information

- Geographical Coordinates:
  - 34°43'40.14"N Latitude and 82°36'47.57"W Longitude
  - Coordinates for the Class Two C&D Landfill Expansion were determined using a reference point centrally located within the developed portion of the Landfill facility.

Alliance Consulting Engineers, Inc.

124 Verdae Blvd., Bonaventure II, Suite 505 Greenville, SC 29607-3843 Phone 864 284-1740 Fax 864 284-1741 www.allianceCE.com

Bluffton, SC | Charleston, SC | Charlotte, NC | Columbia, SC | Greenville, SC

Mr. Justin Koon, Associate Engineer  
SC Department of Health and Environmental Control  
August 15, 2017 - Page 2 of 2

- Location Description:  
The Greenpointe Landfill is located approximately one (1) mile north of Old Greenville Highway Extension (SC Highway 88) along Hamlin Road near the City of Easley, South Carolina.
- Facility Type:
  - Active Class Two Construction and Demolition Debris Landfill
- Annual Disposal Rate:
  - Annual Average Disposal: 35,000 ton/year
  - Permitted Disposal Rate: 57,000 ton/year
- Host County:
  - Anderson County, South Carolina

We trust that this information is to your satisfaction and look forward to your approval. If you have any questions or comments, please do not hesitate to contact our office at (803) 779-2078.

Very truly yours,  
ALLIANCE CONSULTING ENGINEERS, INC.



Mr. Daniel A. Esteban, P.E.  
Regional Manager

Enclosures

cc: Mr. David Oberly, SC Department of Health and Environmental Control w/ enclosures  
Mr. Radford Jenkins, Wasteco, Inc. w/ enclosures  
Mr. Deepal S. Eliatamby, P.E., SCCED, Alliance Consulting Engineers, Inc.  
Mr. Kyle M. Clampitt, P.E., Alliance Consulting Engineers, Inc.  
Ms. Emily N. Palamara, LEED Green Associate, Alliance Consulting Engineers, Inc.



Welcome to: **ACPASS**  
 "Anderson County Public Access System and Services"

[REAL PROPERTY](#) / [VEHICLE TAX](#) / [PROPERTY TAX](#) / [COURTS](#) / [PERMITS](#) / [FORMS](#)

Main=>Real Property=>Property Search=>Select Record=>Property Detail

Property Record Detail								
<a href="#">View Taxes</a>			<a href="#">View Parcel</a>					
TAXMAP NO.			OLD TAMAP NO.			PARENT TMS NO.		
138-00-04-013-000						138-00-04-002		
Owner Information								
Current Owner					Previous Owner			
Name	BJ2 LLC				Name	HILL CHARLES K		
Address	504 CRESCENT AVE				Address	504 CRESCENT AVE		
City, State	GREENVILLE SC				City, State	GREENVILLE SC		
Zip	29601-0000				Zip	29601-0000		
Sales Information								
Date	Book#	Page#	Price	Purchaser				
8/22/2008	8826	00098	\$ 1.00	BJ2 LLC				
8/21/2008	8815	00311	\$ 166,400.00	HILL CHARLES K				
12/12/2006	7754	194	\$ 384,036.00	ELLIS JEFFREY L				
11/30/2006	7725	193		YOUNG RUTH T				
Property Information								
Subdivision					Tax District	103		
Physical Address					Market Value	135,660		
M/H					Prior Value	159,600		
					Tax Value	135,660		
					Exempt			
Legal Description								
Legal Desc 1	CP S 1794/7B							
Legal Desc 2	F000 D000 PP S 1657/10							
Legal Desc 3	PT TR C HENDRICKS RD 15.96 AC							
Assessment Totals								
YEAR	ACRES	LOTS	LAND ASMT	#BLDG	BLDG ASMT	TOT ASMT	RAT CD	RC
2016	15.96		80			80	A	
2015	15.96		80			80	A	
2014	15.96		80			80	A	
2013	15.96		80			80	A	01

Legal Disclaimer - HELP - Privacy Disclaimer

COPYRIGHT 2002, ANDERSON COUNTY SC





Welcome to: **ACPASS**  
 "Anderson County Public Access System and Services"

[REAL PROPERTY](#) / [VEHICLE TAX](#) / [PROPERTY TAX](#) / [COURTS](#) / [PERMITS](#) / [FORMS](#)

Main=>Real Property=>Property Search=>Select Record=>Property Detail

Property Record Detail								
<a href="#">View Taxes</a>			<a href="#">View Parcel</a>					
TAXMAP NO.			OLD TAMAP NO.			PARENT TMS NO.		
<b>164-00-02-036-000</b>								
Owner Information								
Current Owner					Previous Owner			
Name	BJ2 LLC				Name	JENKINS ROBERT R		
Address	PO BOX 8028				Address	PO BOX 8028		
City, State	GREENVILLE SC				City, State	GREENVILLE SC		
Zip	29604-0000				Zip	29604-0000		
Sales Information								
Date	Book#	Page#	Price	Purchaser				
8/04/2009	9287	00110	\$ 1.00	BJ2 LLC				
9/14/2005	6955	00261	\$ 1,018,316.00	JENKINS ROBERT R				
5/31/2001	4205	187	\$ 330,000.00	VANESKY GARY				
3/02/1959	11S	121		HUNT ISABEL RUTH ALLGOOD				
Property Information								
Subdivision					Tax District	103		
Physical Address	500 HAMLIN RD				Market Value	1,018,220		
M/H					Prior Value	508,041		
					Tax Value	556,408		
					Exempt			
Legal Description								
Legal Desc 1	CP S 1228/4+5							
Legal Desc 2	F000 D000							
Legal Desc 3	HAMLIN RD 195.83 AC							
Assessment Totals								
YEAR	ACRES	LOTS	LAND ASMT	#BLDG	BLDG ASMT	TOT ASMT	RAT CD	RC
2016	195.83		11430	3	2340	13770	A C	
2015	195.83		11430	3	2340	13770	A C	
2014	195.83		11430	3	2340	13770	A C	
2013	195.83		11430	3	2340	13770	A C	03

Legal Disclaimer - HELP - Privacy Disclaimer

COPYRIGHT 2002, ANDERSON COUNTY SC





August 15, 2017

Mr. Justin Koon, Associate Engineer  
Division of Mining and Solid Waste Management  
Bureau of Land & Waste Management  
SC Department of Health and Environmental Control  
2600 Bull Street  
Columbia, South Carolina 29201

Re: Preliminary Determination of Consistency for  
the Expansion of the Greenpointe Landfill in  
Anderson County, South Carolina  
Permit No. LF2-001

Dear Mr. Koon:

Wasteco, Inc., in conjunction with Alliance Consulting Engineers, Inc. is proposing to permit the Expansion of the existing Greenpointe Class Two Construction and Demolition Debris (C&D) Landfill located along Hamlin Road in Anderson County, South Carolina in accordance with the South Carolina Department of Health and Environmental Control (SCDHEC) Regulation *R.61-107.19 SWM: Solid Waste Landfills and Structural Fill*, effective May 23, 2008, and *R.61-107.17 Demonstration-of-Need*, effective June 26, 2009. Please consider this to be our formal request to the SCDHEC to conduct the Preliminary Consistency Determination.

The proposed expansion is pursuant to the *Anderson County Solid Waste Management Plan*, dated December 7, 2004; the current zoning, as illustrated in the enclosed Zoning Map and described in the enclosed *Anderson County Code of Ordinances: Section 5:19*, dated May 15, 2015; and the buffer requirements set forth in *R.61-107.19 Part IV, Section B.1.a* as illustrated in the enclosed Existing Buffer Map dated January 13, 2017.

We trust that this information is to your satisfaction and look forward to your approval. If you have any questions or comments, please do not hesitate to contact our office at (803) 779-2078.

Very truly yours,  
ALLIANCE CONSULTING ENGINEERS, INC.

A handwritten signature in blue ink, appearing to read 'D. Esteban', is written over a horizontal line.

Daniel A. Esteban, P.E.  
Regional Manager

Enclosures

cc: Mr. David Oberly, SC Department of Health and Environmental Control w/ enclosures  
Mr. Radford Jenkins, Wasteco, Inc. w/ enclosures  
Mr. Deepal S. Eliatamby, P.E., SCCED, Alliance Consulting Engineers, Inc.  
Mr. Kyle M. Clampitt, P.E., Alliance Consulting Engineers, Inc.  
Ms. Emily N. Palamara, LEED Green Associate, Alliance Consulting Engineers, Inc.

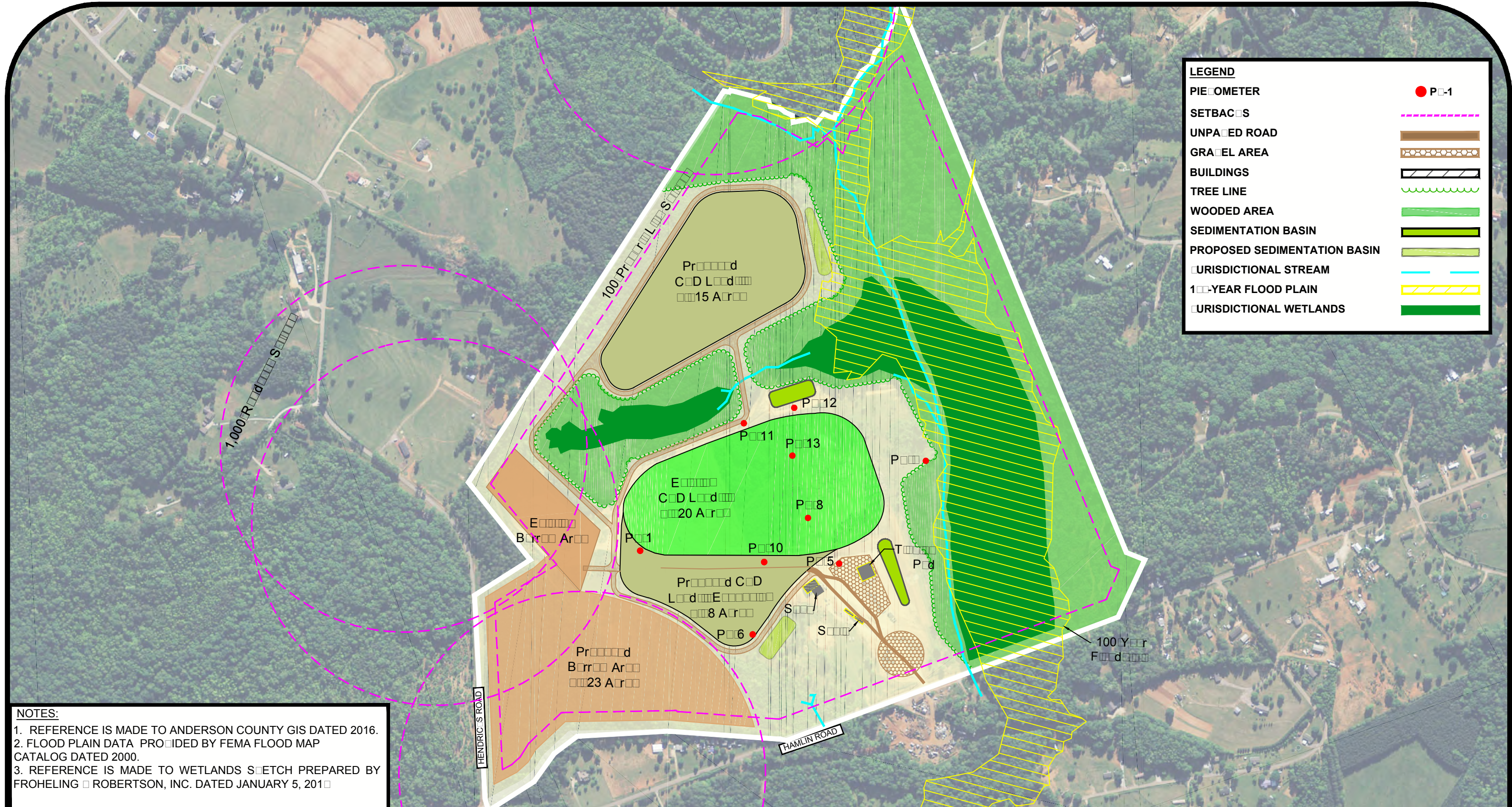

LEGEND	
PERIMETER	P-1
SETBACKS	
UNPAVED ROAD	
GRAVEL AREA	
BUILDINGS	
TREE LINE	
WOODED AREA	
SEDIMENTATION BASIN	
PROPOSED SEDIMENTATION BASIN	
JURISDICTIONAL STREAM	
100-YEAR FLOOD PLAIN	
JURISDICTIONAL WETLANDS	

**NOTES:**  
 1. REFERENCE IS MADE TO ANDERSON COUNTY GIS DATED 2016.  
 2. FLOOD PLAIN DATA PROVIDED BY FEMA FLOOD MAP CATALOG DATED 2000.  
 3. REFERENCE IS MADE TO WETLANDS SKETCH PREPARED BY FROHELING & ROBERTSON, INC. DATED JANUARY 5, 2010

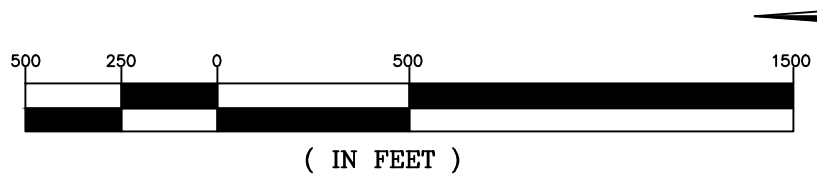

**Essex Barber M...e**  
**+/- 212-Acre Greenfield C&D L&D**  
**Aders Co., S... Cr...**



Project No: 16220000  
 January 13, 2010

# GREENPOINTE CLASS TWO CONSTRUCTION AND DEMOLITION DEBRIS LANDFILL EXPANSION IN ANDERSON COUNTY, SOUTH CAROLINA

## PLANNING MAP

**Wasteco, Inc.**

+/- 212 Acres

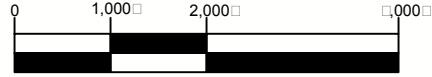

GRAPHIC SCALE  
AUGUST 2011



PREPARED BY:  
ALLIANCE CONSULTING ENGINEERS, INC.  
INFORMATION FROM:  
USDA NRCS GEOSPATIAL DATA GATEWAY  
ANDERSON COUNTY, SOUTH CAROLINA  
DATED 2011

PICKENS COUNTY  
ANDERSON COUNTY

HENDRICKS ROAD

HAMILTON ROAD

88

**SITE**

### LEGEND

- R-A
- R-40
- R-20
- R-15
- R-12
- R-10
- R-8
- R-D
- R-M1
- R-M2
- R-M7
- R-M
- R-MA
- R-MHP
- O-D
- POD
- C-1N
- C-1R
- C-1
- C-2
- C-3
- S-1
- I-1
- I-2
- PD
- AP
- RRD

## Section 5:19. - S-1, Services District.

This district is established to provide a transition between commercial and industrial districts by allowing: 1) commercial uses which are service related; 2) service-related commercial uses which sell merchandise related directly to the service performed; 3) commercial uses which sell merchandise which requires storage in warehouses or outdoor areas; and 4) light industries which in their normal operations would have a minimal effect on adjoining properties. All of the uses permitted in this district shall be conducted in such a manner that no noxious odor, fumes, smoke, dust, or noise will be admitted beyond the property line of the lot on which the use is located.

*5:19.1. Uses permitted.*

Air conditioning equipment, sales and service.

Ambulance service.

Amusements—Commercial.

Animal shelters.

Auction house.

Automobile body shop.

Automobile garage.

Automobile parking.

Automobile painting.

Automobile parts or accessories.

Automobile rental.

Automobile repairing.

Automobile sales.

Automobile service station.

Automobile storage.

Automobile upholstery.

Automobile wash, automated.

Automobile wash, full-service.

Automobile wash, self-service.

Barber shop.

Baseball batting range.

Beauty shop.

Broadcasting studios, radio or television.

Building materials.

Cemeteries (30 acre minimum).

Communication towers. (Subject to the provisions of section 7:18.)

Continuing care retirement center.

Dental laboratories.

Diaper supply service.

Drive-in business. (Theatres, restaurants, etc.)

Eating establishments.

Electric motor repair.

Engravers.

Exhibition buildings, galleries, or showrooms.

Farm machinery sales.

Feed and seed store.

Funeral home.

Gas sales—Commercial and industrial (Oxygen and acetylene.)

Golf courses.

Golf courses—Par three.

Golf driving ranges.

Group industrial development. (Subject to the provisions of section 6:12.)

Gunsmith.

Horse show.

Household appliance repair.

Ice skating rink.

Laboratories—Analytical, experimental, testing, or industrial processes.

Landfills—Sanitary.

Laundries—Dry cleaning, or linen supply service

Linen or towel supply business.

Lithographing.

Lumber yards.

Manufacturing:

A. Processing of: foodstuffs, beverages.

B. Fabrication of: cloth, wood, leather, paper, plastic, or metal.

Mattress shop.

Medical clinic or laboratory.

Mimeographing service.

Manufactured home sales.

Monuments and tombstones sales.

Motel.

Motorcycle sales and service.

Newspaper establishment.

Nursery—Flower, plant, or tree.

Nursery supply.

Nursing care facility.

Offices .

Office supply and equipment.

Parking areas.

Parking structures, commercial.

Pest or insect control business.



Photo developing and refinishing.

Plumbing shop.

Printing or binding.

Radio or television broadcasting studio.

Radio or television repair.

Recording studio.

Recycling collection center. (Subject to the provisions of section 7:13.)

Recycling convenience center. (Subject to the provisions of section 7:13.)

Recycling drop box. (Subject to the provisions of section 7:13.)

Recycling drop-off trailer. (Subject to the provisions of section 7:13.)

Restaurant.

Riding stables.

Roller skating rink.

Safe and vault repair.

Service stations.

Sexually oriented businesses. (Subject to section 42-400 of the Anderson County Code of Ordinances.)

Sign painting.

Signs—Advertising. (Subject to the provisions of the sign ordinance.)

Signs—Business. (Subject to the provisions of the sign ordinance.)

Signs—Occupancy. (Subject to the provisions of the sign ordinance.)

Signs—Temporary. (Subject to the provisions of the sign ordinance.)

Sporting goods sales.

Swimming pool—Commercial

Taxi business.

Taxidermist.

Telephone exchange.

Tire shop.

Truck terminals.

Utility easement or right-of-way.

Utilities—Public or private.

Venetian blinds—Laundry, servicing, and repairing.

Veterinary clinics.

Veterinary hospitals.

Veterinary offices.

Welding.

Wholesaling and warehousing.

Other uses that are considered to be compatible with the aforementioned uses.

*5:19.2. Uses permitted by special exception.*

Auditorium.

Baseball park.

Church.

Correctional institution.

Dwelling unit accessory. (Subject to the provisions of section 7:10.)

Fairgrounds.

Fire station.

Football stadium.

Hospital.

Police station.

Recycling processing center. (Subject to the provisions of section 7:13.)

Station—Bus or railway.

Certain retail sales establishments which are customarily accessory and clearly incidental and subordinate to permitted principal office uses, such as, but not limited to the following:

Apothecary.

Barber shop.

Beauty shop.

Cafeteria.

Florist shop.

Newsstand.

Optician.

Restaurant.

Sales or rental of medical supplies and prosthetic devices.

Sandwich shop.

Similar retail uses which are designed primarily to serve the convenience of persons working or receiving services in the building in which the accessory use is located, provided that such accessory use is clearly incidental and subordinate to principal permitted uses.

5:19.3. *Height limitation.* No building or structure shall exceed 45 feet in height except as provided in [section 6:7](#). No building or structure on a lot in the Services District which is adjacent to a residential district shall exceed the maximum building height permitted in the residential district, unless there is one additional foot of setback on the sides adjacent to the residential district for each additional foot of height.

5:19.4. *Dimensional requirements.*

5:19.4-1. *Front setback.* All buildings shall be set back from street right-of-way lines not less than 45 feet.

5:19.4-2. *Side setback.* No building shall be located closer than 25 feet to a side lot line, except when the property is adjacent to a railroad right-of-way, and written approval from the railroad authorities has been obtained, to utilize a railroad spur for loading and unloading.

5:19.4-3. *Rear setback.* No building shall be located closer than 25 feet to a rear lot line, except when the property is adjacent to a railroad right-of-way, and written approval from the Railroad authorities has been obtained, to utilize a railroad spur for loading and unloading.

5:19.5. *Screening.* A combination of a wall or fence and dense evergreen hedge or other type of evergreen foliage at least six feet in height shall be provided along the side and rear lot lines where any commercial use is adjacent to a residential district for the purpose of screening commercial activities

from view.

5:19.6. *Off-street parking.* Off-street parking shall be provided in accordance with the provisions set forth in section 6:9.

5:19.7. *Off-street loading.* Off-street loading shall be provided in accordance with the provisions set forth in section 6:10.

(Ord. No. 99-004, §§ 5:19—5:19.7, 7-20-99)

**ANDERSON COUNTY**  
**SOLID WASTE MANAGEMENT PLAN**



**ANDERSON**  
**COUNTY**  
SOUTH CAROLINA

December 7, 2004



**ANDERSON  
COUNTY**  
SOUTH CAROLINA

*Making News.  
Making Progress.*

**RECEIVED**

FEB 08 2005

DIVISION OF MINING &  
SOLID WASTE MANAGEMENT  
BL&WM

January 5, 2005

Mr. Rudy Curtis  
SCDHEC Bureau of Land and Waste Management  
2600 Bull Street  
Columbia, SC 29202-1708

RE: Anderson County Solid Waste Management Plan Update

Dear Mr. Curtis:

**County Administrator**

Joey R. Preston

**Council Members**

Clint Wright  
Chairman  
District 4

Mike Holden  
Vice-Chairman  
District 5

G. Fred Tolly, Jr.  
District 1

Gracie S. Floyd  
District 2

Larry E. Greer  
District 3

William C. Dees  
District 6

M. Cindy Wilson  
District 7

**Clerk to Council**

Linda N. Gilstrap

Enclosed please find the Anderson County Solid Waste Management Plan, dated December 7, 2004. Anderson County is submitting this Plan as a revision to the Plan currently on file with the Department. Please replace the Plan on file, in it's entirety, with this document dated December 7, 2004.

This Plan was approved on third reading by Anderson County Council on December 7, 2004 and will be considered effective on this date. The Plan was approved through the appropriate County procedures including the opportunity for public involvement.

Should you have any questions or comments, please do not hesitate to contact either Mr. Joey Preston, Administrator, or myself.

Very truly yours,

*Victor J. Carpenter*  
Victor J. Carpenter  
Director, Environmental Services Division

Enclosures

cc: Mr. Joey Preston, Anderson County Adminsitrator



2001, 2002 J. Mitchell Graham Award Winner  
for Excellence in Governmental Performance  
2002 Government Regional Cooperation Award Winner

Post Office Box 8002 • Anderson, S.C. 29622-8002  
(864) 260-4000

[www.andersoncountysc.org](http://www.andersoncountysc.org)

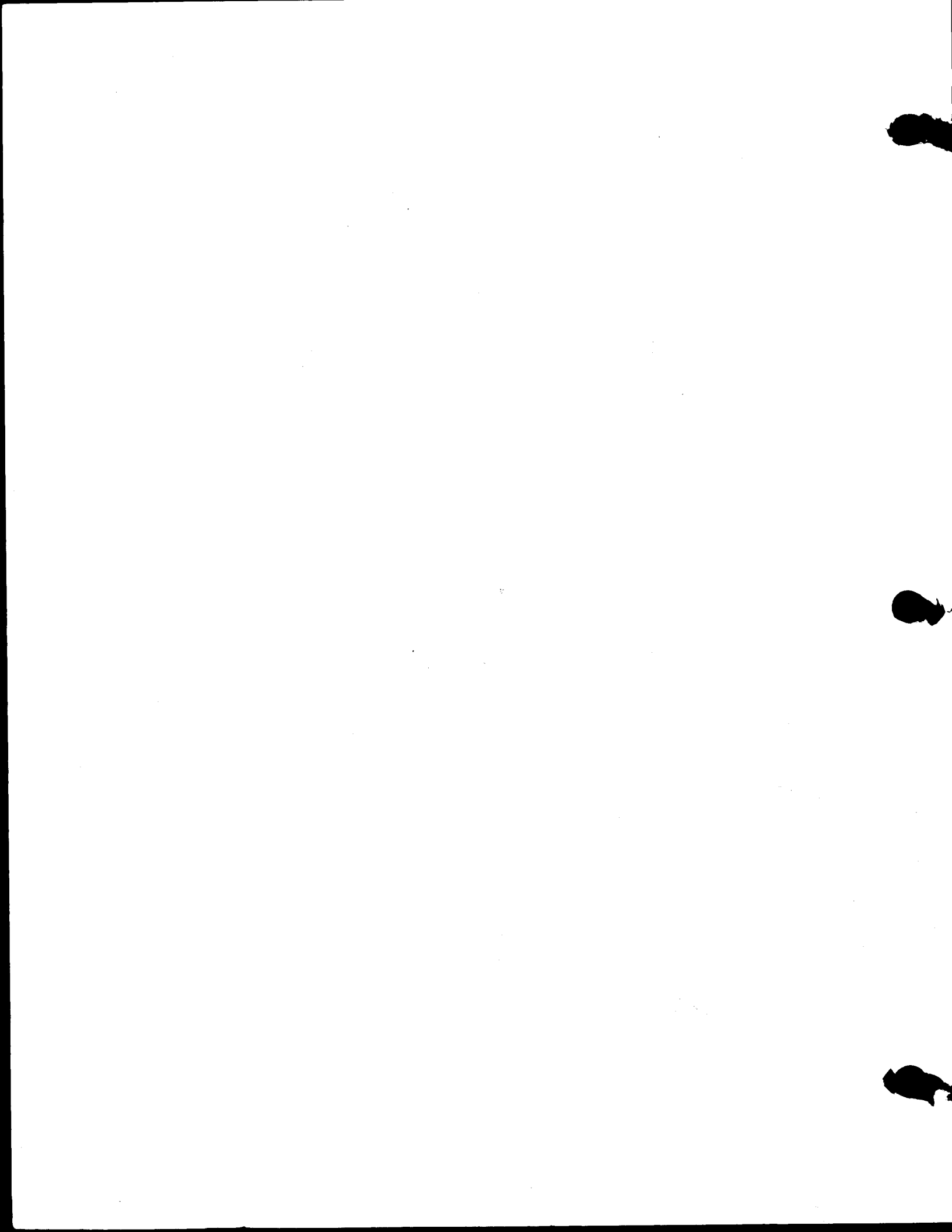

**RECEIVED**

FEB 08 2005

DIVISION OF MINING &  
SOLID WASTE MANAGEMENT  
BL&WM

**ANDERSON COUNTY  
SOLID WASTE MANAGEMENT PLAN**

December 7, 2004

**The information contained herein provides an overview of the current status and future expectations of solid waste management in Anderson County and does not specifically address or benefit the operations of a particular individual or entity.**



**TABLE OF CONTENTS**

<b>I. INTRODUCTION .....</b>	<b>I-1</b>
A. PLAN DEVELOPMENT.....	I-1
B. ANNUAL PLAN REVISION.....	I-2
C. ANNUAL PROGRESS REPORTS.....	I-3
<b>II. LEGISLATIVE AUTHORITY .....</b>	<b>II-1</b>
A. FEDERAL & STATE REGULATIONS .....	II-1
B. EXISTING ORDINANCES .....	II-2
C. PROPOSED ORDINANCES.....	II-2
D. SOLID WASTE POLICIES .....	II-2
E. ORGANIZATION STRUCTURE.....	II-3
<b>III. DEMOGRAPHICS.....</b>	<b>III-1</b>
A. POPULATION TRENDS .....	III-1
B. POPULATION PROJECTIONS .....	III-3
C. ECONOMIC TRENDS .....	III-5
D. LAND USE .....	III-5
<b>IV. EXISTING SOLID WASTE MANAGEMENT.....</b>	<b>IV-1</b>
A. GENERATION & CHARACTERIZATION .....	IV-1
B. COLLECTION, TEMPORARY STORAGE, & TRANSPORTATION OF SOLID WASTE.....	IV-2
1. Convenience Centers .....	IV-2
2. Curbside Collection .....	IV-6
C. SOLID WASTE TRANSFER STATIONS .....	IV-10
D. SOLID WASTE PROCESSING FACILITIES.....	IV-13
E. MUNICIPAL SOLID WASTE (MSW) LANDFILLS.....	IV-16
F. SLUDGE MONOFILLS.....	IV-20
G. INCINERATOR ASH MONOFILLS .....	IV-20
H. CONSTRUCTION, DEMOLITION, & LAND-CLEARING DEBRIS (C&D) LANDFILLS.....	IV-21
1. Part I (Short-Term) C&D Landfills .....	IV-21
2. Part II-General Permits for Land-Clearing & Yard Trash .....	IV-23
3. Part III C&D Landfills .....	IV-25
4. Part IV C&D Landfills.....	IV-26
I. INDUSTRIAL SOLID WASTE (ISW) LANDFILLS .....	IV-28
1. Class 1 ISW Landfills .....	IV-29
2. Class 2 ISW Landfills .....	IV-31
3. Class 3 ISW Landfills .....	IV-31
J. MUNICIPAL SOLID WASTE INCINERATORS.....	IV-31
K. COMPOSTING AND WOOD CHIPPING/SHREDDING FACILITIES.....	IV-31
L. USED OIL COLLECTION & PROCESSING FACILITIES .....	IV-34
M. WASTE TIRE FACILITY PERMITS .....	IV-35
N. RESEARCH, DEVELOPMENT, & DEMONSTRATION (RD&D) PERMITS .....	IV-36
O. LAND APPLICATION OF SOLID WASTE PERMITS.....	IV-36
P. RECYCLING PROGRAMS .....	IV-36
Q. SPECIAL WASTES .....	IV-41

R.	HOUSEHOLD HAZARDOUS MATERIALS (HHM) .....	IV-41
S.	IMPORT & EXPORT OF WASTE .....	IV-42
T.	SOLID WASTE DEPARTMENT FUNDING .....	IV-42
<b>V.</b>	<b>FUTURE SOLID WASTE MANAGEMENT FACILITIES.....</b>	<b>V-1</b>
A.	WASTE STREAM PROJECTIONS.....	V-1
B.	FUTURE WASTE MANAGEMENT FACILITIES .....	V-4
C.	COLLECTION, TEMPORARY STORAGE, & TRANSPORTATION OF SOLID WASTE.....	V-5
D.	SOLID WASTE TRANSFER STATION .....	V-7
E.	SOLID WASTE PROCESSING FACILITIES.....	V-8
F.	MUNICIPAL SOLID WASTE (MSW) LANDFILLS.....	V-8
G.	SLUDGE MONOFILLS.....	V-11
H.	INCINERATOR ASH MONOFILLS .....	V-11
I.	CONSTRUCTION, DEMOLITION, & LAND-CLEARING DEBRIS (C&D) LANDFILLS.....	V-11
J.	INDUSTRIAL SOLID WASTE (ISW) LANDFILLS .....	V-14
K.	SOLID WASTE INCINERATORS .....	V-16
L.	COMPOSTING & WOOD CHIPPING/SHREDDING FACILITIES .....	V-16
M.	USED OIL COLLECTION & PROCESSING FACILITIES .....	V-16
N.	WASTE TIRE HAULERS, COLLECTION FACILITIES, PROCESSING FACILITIES & DISPOSAL FACILITIES .....	V-17
O.	RESEARCH, DEVELOPMENT, & DEMONSTRATION (RD&D) PERMITS .....	V-17
P.	LAND APPLICATION OF SOLID WASTE PERMITS .....	V-18
Q.	RECYCLING PROGRAMS .....	V-18
R.	SPECIAL WASTES .....	V-19
S.	HOUSEHOLD HAZARDOUS MATERIALS (HHM) .....	V-19
T.	IMPORT & EXPORT OF WASTES.....	V-19
<b>VI.</b>	<b>GOALS, POLICIES, STRATEGIES, &amp; BARRIERS.....</b>	<b>VI-1</b>
A.	REDUCTION GOALS .....	VI-1
B.	RECYCLING GOALS .....	VI-2
C.	POLICIES.....	VI-3
D.	STRATEGIES.....	VI-3
1.	Educational Programs .....	VI-3
2.	Grants.....	VI-6
3.	Technical Assistance.....	VI-6
E.	BARRIERS .....	VI-7
<b>VII.</b>	<b>PLAN REVISION &amp; CONSISTENCY WITH WASTE MANAGEMENT PLANS .....</b>	<b>VII-1</b>
A.	ANNUAL PROGRESS REPORTS .....	VII-1
B.	REVISIONS TO THE ANDERSON COUNTY SOLID WASTE MANAGEMENT PLAN .....	VII-2
C.	CONSISTENCY DETERMINATIONS & DEMONSTRATION-OF-NEED REQUIREMENTS .....	VII-2

**List of Figures**

Figure III-1 – Anderson County Population Projections Through 2025 ..... III-4

**List of Tables**

Table III-1- Population Counts for Anderson County Municipalities ..... III-2  
Table III-2- Anderson County Population Projections (2005-2025) ..... III-3  
Table III-3 – Unemployment Rate Trend ..... III-5  
Table V-1- Municipal Solid Waste Projections ..... V-2  
Table V-2- C&D Debris Projections..... V-3

**List of Exhibits**

Exhibit A – Convenience Centers.....IV-3  
Exhibit B – Solid Waste Transfer Stations .....IV-12  
Exhibit C – Processing Facilities .....IV-14  
Exhibit D – MSW Landfills.....IV-17  
Exhibit E – C&D Landfills .....IV-22  
Exhibit F – ISW Landfills.....IV-30  
Exhibit G – Composting Facilities.....IV-32  
Exhibit H – Solid Waste Facilities..... V-9  
Exhibit I – MSW Landfill Radius Map..... V-10  
Exhibit J – Commercial C&D Landfills ..... V-12  
Exhibit K – Commercial ISW Landfill Planning Map ..... V-15

**List of Appendix**

Appendix A – Anderson County Solid Waste Ordinance

**I. INTRODUCTION**

Anderson County is located in the upstate of South Carolina and is comprised of approximately 757 square miles with a population of 165,740 (2000 Census). The County is bordered to the north by both Oconee County and Pickens County, to the northeast by Greenville County, to the east by Laurens County, to the south by Abbeville, and to the west by Hart County, Georgia. Municipalities within the County include the City of Anderson, City of Belton, Town of Honea Path, Town of Iva, Town of Pelzer, Town of Pendleton, Town of Starr, Town of West Pelzer and the Town of Williamston.

**A. PLAN DEVELOPMENT**

In 1991, the South Carolina General Assembly passed new legislation regarding the disposal of solid waste after the Environmental Protection Agency (EPA) became concerned with existing handling and disposal practices. On May 27, 1991, Governor Carroll Campbell signed the South Carolina Solid Waste Policy and Management Act of 1991, as amended (the Act) into Law. The Act, as codified in Section 44-96-10 of the Code of Laws of South Carolina (1976), as amended (the Code), addresses regulation and requirements related to the planning, development, and operation of solid waste management facilities in South Carolina. The Anderson County Solid Waste Management Plan (the Plan), as amended, was prepared following the guidelines specified through the Act as a guidance document for solid waste management in Anderson County (the County) during a planning period of twenty (20) years (1994 – 2013). The Plan was initially developed in 1994 through the contributions of the fifteen (15) member Anderson County Solid Waste Advisory Committee (SAC). The Anderson County Solid Waste Management Plan was adopted by Anderson County Council on October 28, 1997.

In April 2004, South Carolina Department of Health and Environmental Control (SCDHEC) developed a new procedure for determining consistency with solid waste management plans, pursuant to a decision by the South Carolina Supreme Court in Southeastern Resource Recovery, Inc. versus SCDHEC, et al, 595 S.E.2d 468 (2004). As a result of this ruling, SCDHEC could no longer delegate to the counties the authority to determine consistency. SCDHEC would determine consistency by utilizing the Solid Waste Management Plan on file with the Department.

The Plan, as amended, is an overview of the County's solid waste management within the County and the municipalities of Anderson, Belton, Honea Path, Iva, Starr, Pelzer, Pendleton, West Pelzer and Williamston, and does not specifically address or benefit the operations of a particular individual or entity, or does the Plan impose new or increase existing fees or charges associated with the collection, transfer, and disposal of solid waste and recyclable materials.

The information included in the Plan was obtained from the Anderson County Solid Waste Management Plan dated 1997, Anderson County Environmental Services Division, Anderson County Planning Division, SCDHEC, and South Carolina Budget and Control Board Office of Research and Statistics. Copies of the Plan are available for review and inspection from the County upon request.

**B. ANNUAL PLAN REVISION**

As outlined in the Act, as amended, the Plan must be reviewed annually and updated, as needed, to include changes that are deemed necessary at the time. The Anderson County Environmental Services Division will review the Plan and present proposed revisions to Anderson County Council (Council) for consideration, public comment, and subsequent approval by Resolution. Once revisions have been presented to and approved by Council, the corresponding

amended sections of the Plan will be submitted to SCDHEC by either the Administrator or the Director of the Anderson County Environmental Services Division. All modified portions of the Plan will include the date of the revision to ensure that both SCDHEC and Anderson County reference the most current documentation.

**C. ANNUAL PROGRESS REPORTS**

Anderson County is required by the Act to prepare and submit an Annual Progress Report to SCDHEC by October 1<sup>st</sup> of each year. The annual progress report will be prepared by the Anderson County Environmental Services Division and will include information on all solid waste collection, disposal and recycling activities within the County.

All owners and/or operators of solid waste facilities within the County must submit an Annual Progress Report to the Environmental Services Division by September 1<sup>st</sup> of each year, including: physical location, tonnage received during the previous year, capacity remaining, life expectancy, regulatory compliance history and other pertinent information.

In addition, all private waste hauling companies must submit an Annual Progress Report to the Environmental Services Division by September 1<sup>st</sup> of each year, including: amount of waste collected during the previous year, the number of households served, and other pertinent information requested by the County.

## II. LEGISLATIVE AUTHORITY

Solid waste management facilities in Anderson County are governed by federal, state and local regulations. The United States Environmental Protection Agency (EPA) and the South Carolina Department of Health and Environmental Control (SCDHEC) have established regulations regarding the management of solid waste. These regulations, in conjunction with Anderson County's Code of Ordinances, provide guidance and assistance for the planning and implementation of solid waste management facilities.

### A. FEDERAL & STATE REGULATIONS

The EPA enacted the Resource Conservation and Recovery Act (RCRA) of 1976 as the primary federal law regulating solid waste management. The law is divided into two (2) major sections. The first section, Subtitle C (Hazardous Waste), established a national regulatory program to control the management of hazardous wastes. South Carolina received authorization from the EPA to begin regulating these activities in 1985. The second section of the RCRA is Subtitle D (Solid Waste). This section established a framework for federal, state, and local government cooperation for solid waste management. As a result of this law, the federal government provides minimum national standards for protecting human health, the environment and further provides technical assistance to states for planning and implementing their individual solid waste management policies.

The principal law that governs solid waste management within the State of South Carolina is the South Carolina Solid Waste Policy and Management Act of 1991, as amended (the Act). The Act authorizes SCDHEC to enforce the appropriate federal and/or state standards. Therefore, SCDHEC implemented the Municipal Solid Waste Landfills Regulation, R. 61-107.258, which regulates all municipal solid waste management within the State. Additional regulations are in place for the management of Solid Waste Processing, Solid

Waste Collection and Transportation, Lead-Acid Batteries, Waste Tires, Used Oil, etc. In 1999, SCDHEC revised the South Carolina Solid Waste Management Plan which outlines the existing solid waste management systems within the State and mandates new goals with regards to recycling and reduction.

Section 44-96-80 (J) of the Code gives the governing body of each county the responsibility and authority to provide for the management of solid waste within the county. Each county can enact ordinances that may be necessary to control the processing and disposal of solid waste.

**B. EXISTING ORDINANCES**

The County has adopted ordinances, as codified in the Anderson County Code of Ordinances, regulating solid waste and recycling activities in the County. These ordinances are included in the Appendix of this Plan. Please contact the Environmental Services Division for a current list of applicable Ordinances enforced by the County.

**C. PROPOSED ORDINANCES**

No new solid waste ordinances are pending at this time.

**D. SOLID WASTE POLICIES**

The County strives to operate its solid waste management system in a manner that is efficient and economical, while protecting human health and the environment. Therefore, the County does not permit any open dumping or littering.

All County convenience centers are for the use of County residents only, unless special provisions are granted by the Anderson County Environmental Services Division. Scavenging is strictly prohibited at all County Solid Waste



Management Facilities, including the convenience centers, recycling centers, and landfills.

**E. ORGANIZATION STRUCTURE**

The Anderson County Environmental Services Division is responsible for the operation of the County's solid waste management system. The Environmental Services Division employs approximately forty-five (45) personnel for the management of solid waste activities in the County including the operation of the convenience centers. The solid waste representatives for the County are as follows:

Mr. Vic Carpenter, Environmental Services Director

731 Michelin Boulevard  
Anderson, South Carolina 29626  
Telephone: (864) 260-1001  
Facsimile: (864) 260-1002  
E-Mail: [vcarpenter@andersoncountysc.org](mailto:vcarpenter@andersoncountysc.org)

Mr. David Scott, P.E., Environmental Engineering Manager

731 Michelin Boulevard  
Anderson, South Carolina 29626  
Telephone: (864) 260-1001  
Facsimile: (864) 260-1002  
E-Mail: [dscott@andersoncountysc.org](mailto:dscott@andersoncountysc.org)

Mr. Greg Smith, Solid Waste Manager

731 Michelin Boulevard  
Anderson, South Carolina 29626  
Telephone: (864) 260-1001  
Facsimile: (864) 260-1002  
E-Mail: [gsmith@andersoncountysc.org](mailto:gsmith@andersoncountysc.org)

Ms. Michelle Strange, Keep America Beautiful (KAB) Coordinator

101 South Main Street  
Anderson, South Carolina 29624  
Telephone: (864) 260-1004  
Facsimile: (864) 260-4044  
E-Mail: [mstrange@andersoncountysc.org](mailto:mstrange@andersoncountysc.org)

Mr. Jeff Ricketson, Planning Director  
101 South Main Street  
Post Office Box 8002  
Anderson, South Carolina 29624  
Telephone: (864) 260-4043  
Facsimile: (864) 260-4044  
E-Mail: [jricketson@andersoncountysc.org](mailto:jricketson@andersoncountysc.org)

To ensure open and public participation in the solid waste management process, the County reserves the right to create a seven-member solid waste advisory committee in accordance with Section 2-351 of the Anderson County Code of Ordinances, which will work in conjunction with the Anderson County Solid Waste and Recycling Department and the Keep America Beautiful Advisory Committee to review and recommend, where appropriate, legislative and policy changes regarding solid waste management within the County.

### III. DEMOGRAPHICS

Factors affecting solid waste management and the facilities required to meet public demand for disposal and recycling, include population and economic growth. The United States Census Bureau released the results of the 2000 census on April 1, 2000. This data, in conjunction with population projects provided by the South Carolina Budget and Controls Board's Office of Research and Statistics, aids in determining solid waste management requirements to provide disposal and recycling services to Anderson County residents. Additionally, an increase in economic growth within an area generally indicates an increase in solid waste, particularly C&D waste generated during the construction of new facilities. In combination with the amount of growth, the location of the growth is equally important when determining the efficiency of a solid waste management system. Economic trends and countywide land use information was provided by the Anderson County Planning Division to observe these characteristics.

#### A. POPULATION TRENDS

The population of the County is vital to the planning of its solid waste management system. The growth or decline of an area affects the solid waste management system in terms of the amount of waste generated, the number of convenience centers required to serve area residents, and the number of vehicles needed for transport of collected waste. The population of the County and its municipalities from 1990 to 2000 is illustrated in Table III-1 to provide baseline trends for the areas of growth and areas of decline in the County. As illustrated in the Table, the municipalities of Anderson, Belton, Honea Path, Iva, Pelzer, and Williamston experienced an increase in population of approximately 18%. As is the trend in most of the State, the population is moving out of the downtown area, toward more suburban areas. The overall population of the County increased by approximately 12%. As a result of the increased population, the volume of solid waste generated within the County has increased

Solid Waste Management Plan

Anderson County

Location	1990	1999	2000	% Change
Anderson	26,707	26,166	25,514	-4.7%
Belton	4,460	4,208	4,461	0.0%
Honea Path	3,659	3,511	3,504	-4.4%
Iva	1,224	1,208	1,156	-5.9%
Pelzer	72	71	97	25.8%
Pendleton	3,372	3,527	2,966	-13.7%
Starr	164	179	173	5.2%
West Pelzer	944	1,109	879	-7.4%
Williamston	4,115	3,911	3,791	-8.5%
Unincorporated Areas of Anderson County	100,749	118,851	123,199	18.2%
<b>Total</b>	<b>145,466</b>	<b>162,741</b>	<b>165,740</b>	<b>12.2%</b>

Note: "Population Estimates by County by PL



during the past decade and will most likely continue to do so over the following decade.

#### B. POPULATION PROJECTIONS

The US Census Bureau produces July 1<sup>st</sup> population estimates for each year after the last published decennial census, as well as past decades. The decennial census base counts are updated using existing data such as births, deaths, Federal tax returns, Medicare enrollment, and immigration. These population estimates are used to project the population of a given area for future years. It must be noted that these projections of future population are based solely on census data and do not reflect characteristics such as the fertility, mortality, or migration of the actual population within the County.

As illustrated in Table III-2, according to the South Carolina Budget and Control Board Office of Research and Statistics, the County's population will increase from approximately 165,740 in 2000 to approximately 204,750 in 2025 (approximately +23%) The population projections for the years 2005 to 2025 were based upon linear extrapolation. Population estimates from 1980 to 2025 are shown in Figure III-1.

**Table III-2- Anderson County Population Projections (2005-2025)**

Year	Population	Year	Population
2005	172,120	2016	190,697
2006	174,628	2017	192,303
2007	176,234	2018	193,908
2008	177,844	2019	195,514
2009	179,449	2020	196,590
2010	180,280	2021	198,730
2011	182,661	2022	200,335
2012	184,270	2023	201,941
2013	185,876	2024	203,551
2014	187,482	2025	204,750
2015	188,440		

### Anderson County Population Projections through 2025

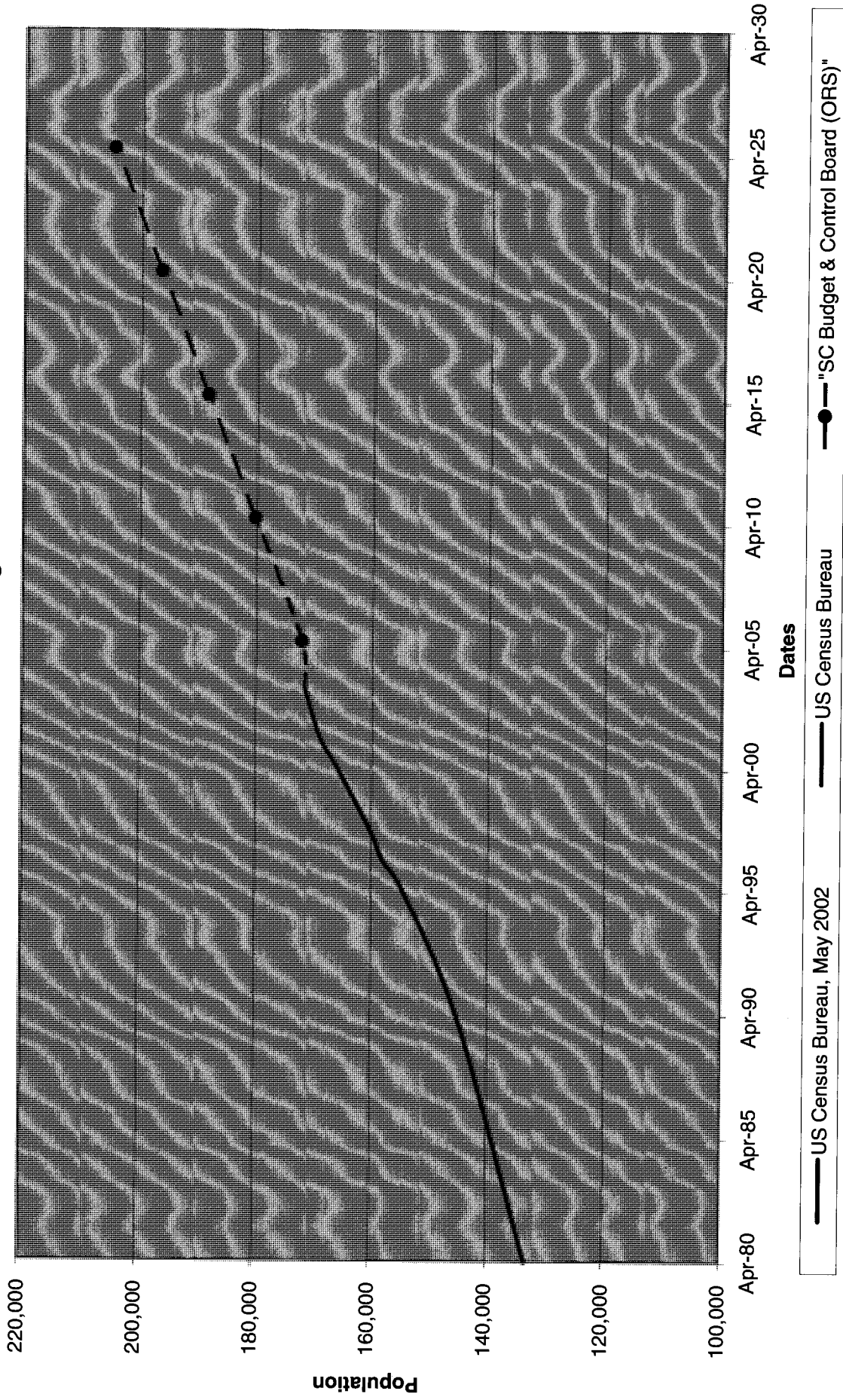

Based upon the current population trends in the County, it is expected that the largest area of growth in the County will be along the Interstate 85 (I-85) corridor and in the suburban areas. As a result, the County should see an increase in its municipal solid waste stream from this area. Projected waste stream generation numbers will be discussed in *Section V – Future Solid Waste Management Facilities*.

**C. ECONOMIC TRENDS**

The characteristics of a local economy are significant indicators of growth. Changes in the economic base of the County will directly affect the solid waste management system in the County and must be an integral part of solid waste planning. The County’s labor force increased by approximately 9,870 persons from 1990 to 2000, a change of approximately +11.5%. As illustrated in Table III-3, as Anderson County grows, the unemployment rate decreases. Generally, as an area’s unemployment rate decreases, the waste stream generated through industrial and commercial business in that area will increase. The County’s unemployment rate has fluctuated during the past decade while residing at or below the State average. It should be noted that not all of the County’s labor force works within the borders of Anderson County, nor does it include workers residing in adjacent counties. As more people are employed in the County, more waste will be generated at both the work place and at home.

**Table III-3 – Unemployment Rate Trend**

Year		Persons Employed in
1990	2000	2000
5.1%	4.5%	77,732

**D. LAND USE**

Land use is an important characteristic to be evaluated in the development and implementation of a solid waste management system because it indicates areas of growth and urban development, both of which result in increased waste



generation. The concentration of population in different areas throughout the County directly affects the collection and transportation of solid waste and recyclables. If the population increases too rapidly in an urbanized area, a strain could be placed on the existing infrastructure, including solid waste management facilities.

The County is located in the Upstate region of South Carolina. The total area, both land and water, is approximately 497,280 acres or 757 square miles. Most of the land in the County is privately owned with the exception of a small amount of land owned by the County, its municipalities, and the State and Federal governments. Even with the County's continued urban growth, land use is primarily agricultural and wooded with the exception of developing areas along the major transportation corridors and within the municipalities. Residential development comprises the majority of urban development in the County.

The primary transportation route through the County is I-85, which connects the metropolitan areas of Charlotte, North Carolina and Atlanta, Georgia. This major corridor is experiencing rapid growth as industry enters the area. Recently, a significant portion of I-85, from mile marker 19 to mile marker 34, was improved to accommodate three (3) travel lanes in both the northbound and southbound directions. The widening of this fifteen (15)-mile section of the Interstate will more than likely further the industrial growth along this corridor.

Other major routes through the County include US Highway 76, SC Highway 28, SC Highway 81, US Highway 29, and SC Highway 24. The routes traverse the County providing both industrial and residential traffic to the growing areas of the County.

Anderson County

The City of Anderson is the largest municipality in Anderson County. The City is centrally located within the County just south of I-85. The majority of the County's population is located in the suburban area of the City of Anderson. The City of Belton is located in the eastern portion of the County, at the intersection of US Highway 76 and SC Highway 247. The Town of Honea Path is also located in the eastern portion of the County at the intersection of SC Highway 252 and US Highway 76. The Town of Pendleton, in the northwestern portion of the County, is located approximately ten (10) miles north of the City of Anderson along US Highway 76. The Towns of Starr and Iva are both located south of the City of Anderson on SC Highway 81. The remaining municipalities of the Town of Williamston, Town of Pelzer, and Town of West Pelzer are all located in the eastern portion of the County along the Saluda River. These municipalities comprise approximately 25% of the County's overall population. The remaining residents are located in the rural areas of the County and in the suburban area surrounding the City of Anderson.

It is anticipated that the future growth in the County will be along the I-85 corridor and in the suburban areas surrounding the City of Anderson. This area will develop due to its existing urban environment, an influx of industrial development, available utility services, and steady economic base, as well as, convenient access to Atlanta, Charlotte and Greenville, South Carolina. As the area grows, the demand for solid waste management services will increase.

**IV. EXISTING SOLID WASTE MANAGEMENT**

The South Carolina Department of Health and Environmental Control (SCDHEC) is responsible for the approval, permitting and/or registering of solid waste related facilities in accordance with the South Carolina Solid Waste Policy and Management Act and Regulation 61-107. Under these regulations, twelve (12) components (facilities) of a solid waste management system are specifically regulated by the type of waste and the disposal process. Several of these regulated facilities are currently in operation within Anderson County.

**A. GENERATION & CHARACTERIZATION**

The Act required that all solid waste facilities conduct accurate record keeping of waste stream data. Also required by the Act, counties must submit annual progress reports to SCDHEC by October 1<sup>st</sup> of each year. According to the SCDHEC's Fiscal Year 2003 Solid Waste Management Annual Report, the County generated the following amounts of waste from July 1, 2002 to June 30, 2003:

Municipal Solid Waste:	174,048 tons
C&D Debris:	52,247 tons

The County only maintains records on solid waste over which it has control, including waste received at the convenience centers and the Starr C&D Landfill. The County also strives to receive accurate waste stream information from the private haulers. The waste figures stated above may include waste generated outside of the County and transported for disposal at private landfills

A waste characterization study was conducted in 1992 to determine what types of wastes were disposed within the County's municipal solid waste landfills. The waste stream data used in the study was obtained between July 1, 1992 and December 31, 1992 and was based on a random sampling technique. The study

revealed that the majority of the waste stream consisted of paper products, yard debris, glass, and plastics. While recycling efforts have reduced the amount of these materials being land filled, a greater emphasis should be placed on the composting of yard debris and the separation of cardboard and paper products from the waste stream.

**B. COLLECTION, TEMPORARY STORAGE, & TRANSPORTATION OF SOLID WASTE**

The collection, temporary storage and transportation of solid waste is regulated by Regulation 61-107.5 of SCDHEC's Solid Waste regulations. This regulation was developed to establish minimum standards for the collection, temporary storage, and transportation of solid waste prior to processing, disposal, etc. of that waste. Anderson County utilized two (2) forms of collection, temporary storage, and/or transportation of solid waste; Convenience Centers and Curbside Collection.

**1. Convenience Centers**

The County owns and operates fourteen (14) convenience centers (Exhibit A) for the collection of household municipal solid waste, white goods, and recyclables. The locations of the Anderson County Convenience Centers are as follows:

**Fork Community Convenience Center**

This facility, located at 399 Simmons Ford Road in Townville.

**Craytonville Community Convenience Center**

The Craytonville Community Convenience Center is located at 200 Wilson Road near the City of Belton.

**Carswell Community Convenience Center**

The Carswell Community Convenience Center is located at 110 Audubon Place near the Town of Iva.

**LEGEND**

Convenience Center ●

**ANDERSON COUNTY  
SOLID WASTE MANAGEMENT FACILITIES  
CONVENIENCE CENTERS**



**EXHIBIT A**

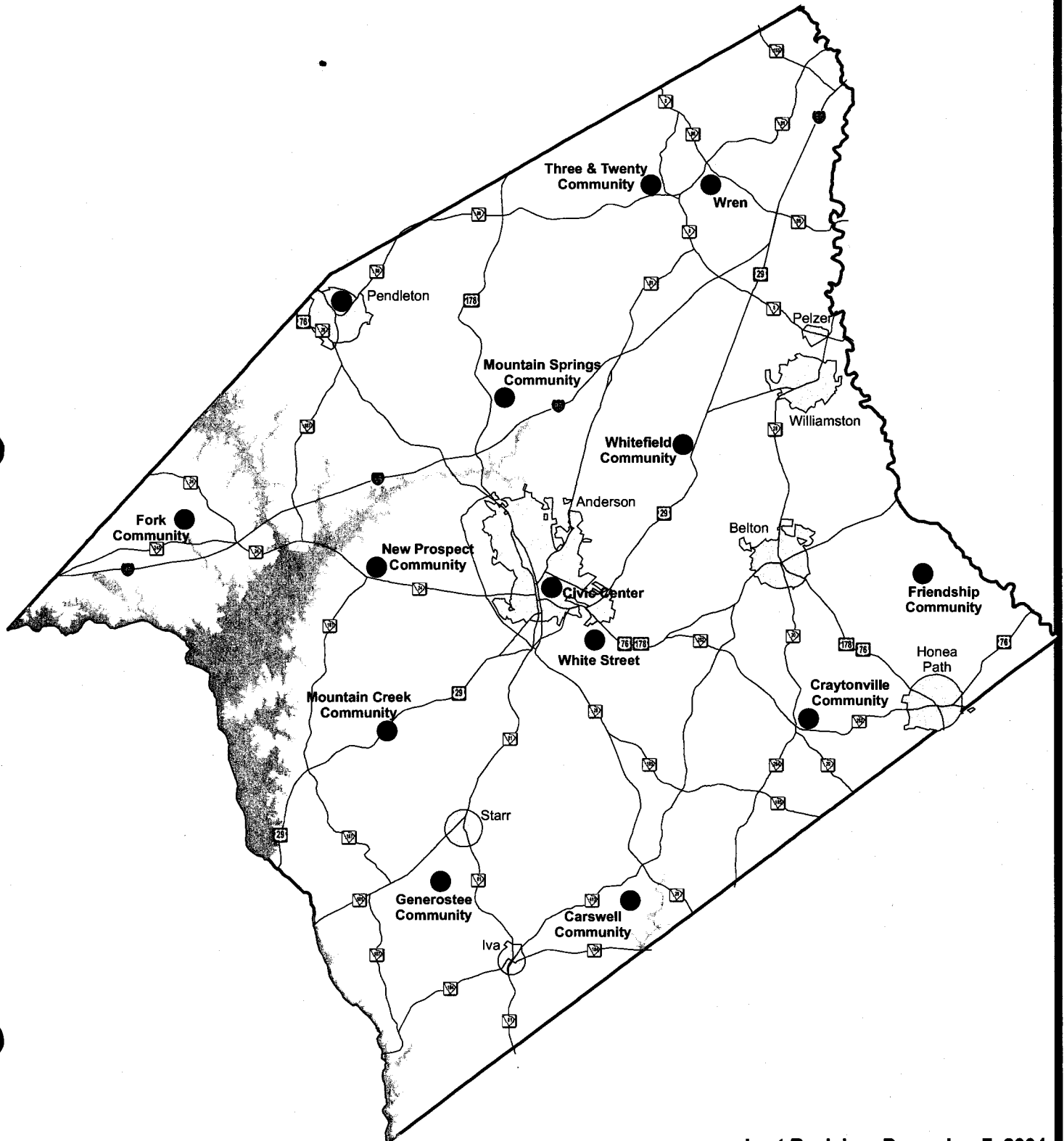

Last Revision: December 7, 2004

**Friendship Community Convenience Center**

This facility is located at 159 Corner Road near the City of Belton.

**Powdersville Community (Three & Twenty) Convenience Center**

The Three and Twenty Convenience Center is located at 1299 Three and Twenty Creek Road near the Town of Easley.

**Whitefield Community (Jockey Lot) Convenience Center**

The Jockey Lot Convenience Center is located at 399 Big Woods Circle near the City of Belton.

**Mountain Creek Community (Agnew) Convenience Center**

The Agnew Convenience Center is located at 2505 Agnew Road near the Town of Starr.

**Generostee Community (Crescent) Convenience Center**

The Generostee Convenience Center is located at 1300 Old Bell Road near the Town of Iva.

**New Prospect Community (King David) Convenience Center**

The King David Convenience Center is located at 200 Echo Circle near the City of Anderson. The operational hours of this facility are 7 a.m. to 7 p.m. Monday through Saturday.

**Mountain Springs Community (Harris Bridge) Convenience Center**

The Mountain Springs Convenience Center is located at 1328 Harris Bridge Road near the City of Anderson.

**White Street Extension Convenience Center – NO C&D**

The White Street Convenience Center is located at 2151 White Street Extension in the City of Anderson.

**Civic Center Convenience Center – Recycling ONLY**

Located off Clemson Boulevard at 3024 Mall Road, across from the Civic Center in the City of Anderson, is open from 8:00 a.m. to 6:00 p.m. seven days a week.

**Wren School Road Convenience Center - unmanned**

This twenty-four (24) hour a day facility is located off SC Highway 86, at 1005 Wren School Road in the Wren Community near the Town of Piedmont.

**Pendleton Convenience Center – unmanned Recycling**

This unmanned facility, located at 600 East Queen Street in Town of Pendleton, is open to the public from 8:00 a.m. to 5:00 p.m. Monday through Friday and 8:00 a.m. to 12:00 p.m. on Saturdays.

The convenience centers are open from 8:00 a.m. to 6:00 p.m., Monday through Saturday unless otherwise specified, and are closed on all holidays observed by the County. Exceptions include the King David Convenience Center, which is open from 7:00 a.m. to 7:00 pm, Monday through Saturday and the Civic Center, which is open Sundays. The convenience centers are reserved for Anderson County residents only, unless special provisions are granted by the Anderson County Environmental Services Division. No business, commercial or industrial companies are allowed to dispose of waste at these locations. The waste collected at the convenience centers is transported to a permitted Subtitle D Landfill for disposal.

Anderson Regional Landfill, LLC owns and operates a solid waste convenience center on Rector Road at the Anderson Regional Landfill during landfill operating hours (see *Section V, Part F – Municipal Solid*

*Waste Landfills*). The convenience center is open to the public. From Belton, take SC Highway 20 north toward Williamston, turn right on Big Creek Road, and turn right on Rector Road. The convenience center is approximately 0.2 miles on the left.

**2. Curbside Collection**

Curbside collection of residential solid waste is available to County residents and commercial businesses by private waste collection companies. The private waste collection companies providing services in the County must register with the Solid Waste and Recycling Department annually for a fee of \$100.00 per company and an additional \$10.00 per vehicle for a registration decal. However, the County does not currently control the amount of waste collected or the service area in which each collection company operates.

Curbside municipal solid waste collection is also provided in the municipalities within the County. Each municipality is responsible for managing its own solid waste and does so as follows:

**City of Anderson**

The City of Anderson provides municipal solid waste and yard debris curbside collection services to its residents. The waste is collected by City personnel once per week and transported to the Anderson Regional Landfill for disposal. Residents are not charged directly for solid waste collection services. The service is funded through property taxes assessed to town residents annually. The City does not have a curbside recycling program. For more information on the City of Anderson's collection services, contact:

Mr. Ronnie Aderhold, Sanitation Supervisor  
City of Anderson Public Works Department  
Telephone: (864) 231-2796  
Facsimile: (864) 231-7936



**City of Belton**

The City of Belton provides municipal solid waste curbside collection to its residents twice each week. The waste is collected by City personnel and transported to the Anderson Regional Landfill. The City also collects yard debris. Residents are not charged directly for solid waste collection services. The service is funded through property taxes assessed to city residents annually. For more information on the City of Belton's collection services, contact:

Mr. D. Blake Foster, Director  
City of Belton Public Works Department  
306 Anderson Street  
Post Office Box 828  
Belton, South Carolina 29627-0828  
Telephone: (864) 338-7495  
Facsimile: (864) 338-8369

**Town of Honea Path**

The Town of Honea Path provides curbside collection to its residents once per week. Town personnel collect the waste and transport it to the Anderson County Regional Landfill for disposal. The Town also collects recyclable materials once per week and transports them to the Anderson Regional Materials Recovery Facility. Yard debris is collected by the Town on an as-needed basis and transported to the Town's Composting Facility. Residents are charged \$6.00 per month for solid waste collection services. For more information on the Town of Honea Path's collection services, contact:

Mr. Thomas Brock, Director  
Town of Honea Path Public Works Department  
30 North Main Street  
Honea Path, South Carolina 29654-1516  
Telephone: (864) 369-7467  
Facsimile: (864) 369-0580

**Town of Iva**

The Town of Iva provides curbside collection services to its residents once per week. Municipal solid waste is collected by a private collector, Robert Stone of Due West, South Carolina and transported to the Anderson County Regional Landfill for disposal. There is no separate collection service for yard debris or recyclable materials. Residents are not charged directly for solid waste collection services. The service is funded through property taxes assessed to town residents annually. For additional information on the Town of Iva's collection services, contact:

Ms. Tim Taylor, Clerk/Treasurer  
Town of Iva  
Post Office Box 188  
Iva, South Carolina 29655-0188  
Telephone: (864) 348-6193  
Facsimile: (864) 348-7562

**Town of Pelzer**

The Town of Pelzer provides curbside collection services to its residents for \$4.40 per month. Municipal solid waste is collected by the private collection company, Cummings, Inc. and is transported to the Anderson Regional Landfill for disposal. No separate collection service is available for yard debris and recyclables. For more information on the Town of Pelzer's collection services, contact:

Mayor D. Page Henderson  
Town of Pelzer  
103 Courtney Street  
Post Office Box 427  
Pelzer, South Carolina 29669-0427  
Telephone: (864) 947-6231  
Facsimile: (864) 947-6266

**Town of Pendleton**

The Town of Pendleton provides curbside collection to its residents. Municipal solid waste and yard debris are collected once per week by Town personnel and transported to the Anderson Regional Landfill for disposal. Recyclable materials are collected by the Town and are transported to the Anderson Regional Material Recovery Facility (MRF). Residents are not charged directly for solid waste collection services. The service is funded through property taxes assessed to city residents annually. For more information on the Town of Pendleton's collection services, contact:

Mr. Richard Bork, Director  
Town of Pendleton Public Works Department  
310 Greenville Street  
Pendleton, South Carolina 29670-1419  
Telephone: (864) 646-9409  
Facsimile: (864) 646-5425  
Website: [www.townofpendleton.org](http://www.townofpendleton.org)

**Town of West Pelzer**

The Town of West Pelzer provides curbside collection to its residents for \$6.00 per month. Once a week, a private collection company, S&S Garbage Collection, Inc. collects municipal solid waste and transports it to the Anderson Regional Landfill for disposal. There is no separate collection schedule for yard debris. For additional information on the Town of West Pelzer's collection services, contact:

Mr. Roger Scott  
Town of West Pelzer Public Works Department  
3 Hindman Street  
West Pelzer, South Carolina 29669-1299  
Telephone: (864) 947-6297  
Facsimile: (864) 947-6297

**Town of Williamston**

The Town of Williamston provides curbside collection to its residents. Town personnel collect municipal solid waste once per week and transport it to the Anderson Regional Landfill for disposal. Recyclable materials are collected once a week and are transported to the Anderson Regional MRF. The Town personnel collect yard debris once a month and transport the material to its composting facility. Residents are not charged directly for solid waste collection services. The service is funded through property taxes assessed to town residents annually. For additional information on the Town of Williamston's curbside collection services, contact:

**Mr. David Roberts, Director**  
Town of Williamston Public Works  
12 West Main Street  
Post Office Box 70  
Williamston, South Carolina 29697-0070  
Telephone: (864) 847-7473  
Facsimile: (864) 847-5910

**C. SOLID WASTE TRANSFER STATIONS**

Two (2) Solid Waste Transfer Stations currently operate within Anderson County (Exhibit B). The White Street Transfer Station is owned by the County, while the Pendleton Transfer Station is owned and operated by Waste Management, Inc. Both of these facilities are governed by SCDHEC Solid Waste Management Regulation 61-107.7.

**Anderson County White Street Transfer Station**

Anderson County owns the White Street Transfer Station (Permit No. 042410-6001), which is located at 2005 White Street within the City of Anderson. The Transfer Station is no longer operational and Anderson County has discontinued the regulatory permit for the facility. For additional information on the White Street Transfer Station, contact:

Mr. Greg Smith, Solid Waste Management Manager  
Anderson County Solid Waste and Recycling Department  
731 Michelin Boulevard  
Anderson, South Carolina 29626  
Telephone: (864) 260-1001  
Fax: (864) 260-1002  
E-Mail: gdsmith@andersoncountysc.org

**Waste Management, Inc. Pendleton Transfer Station**

The Pendleton Solid Waste Transfer Station (Permit No. 042401-6001) is owned and operated by Waste Management, Inc. of South Carolina. This facility is located off US Highway 76 within the Town of Pendleton, in front of the closed Anderson County Pendleton Landfill. The Waste Management Pendleton Transfer Station receives approximately 44,000 tons of waste annually from collection contractors and commercial entities from across the upstate, in addition to area residents. Waste is currently being transported to either Waste Management's Palmetto Landfill in Spartanburg, South Carolina or Waste Management's Homer, Georgia Landfill. The Pendleton Transfer Station has an indefinite life expectancy. For additional information on the Pendleton Transfer Station, contact:

Mr. Deon Barrett  
Waste Management, Inc.  
Post Office Box 5439  
Spartanburg, South Carolina 29304  
Telephone: (864) 949-5407  
Or  
502 Woody Road  
Pendleton, South Carolina 29670  
Telephone: (864) 646-6412

**LEGEND**

Transfer Stations



**ANDERSON COUNTY  
SOLID WASTE MANAGEMENT FACILITIES  
TRANSFER STATIONS**



**EXHIBIT B**

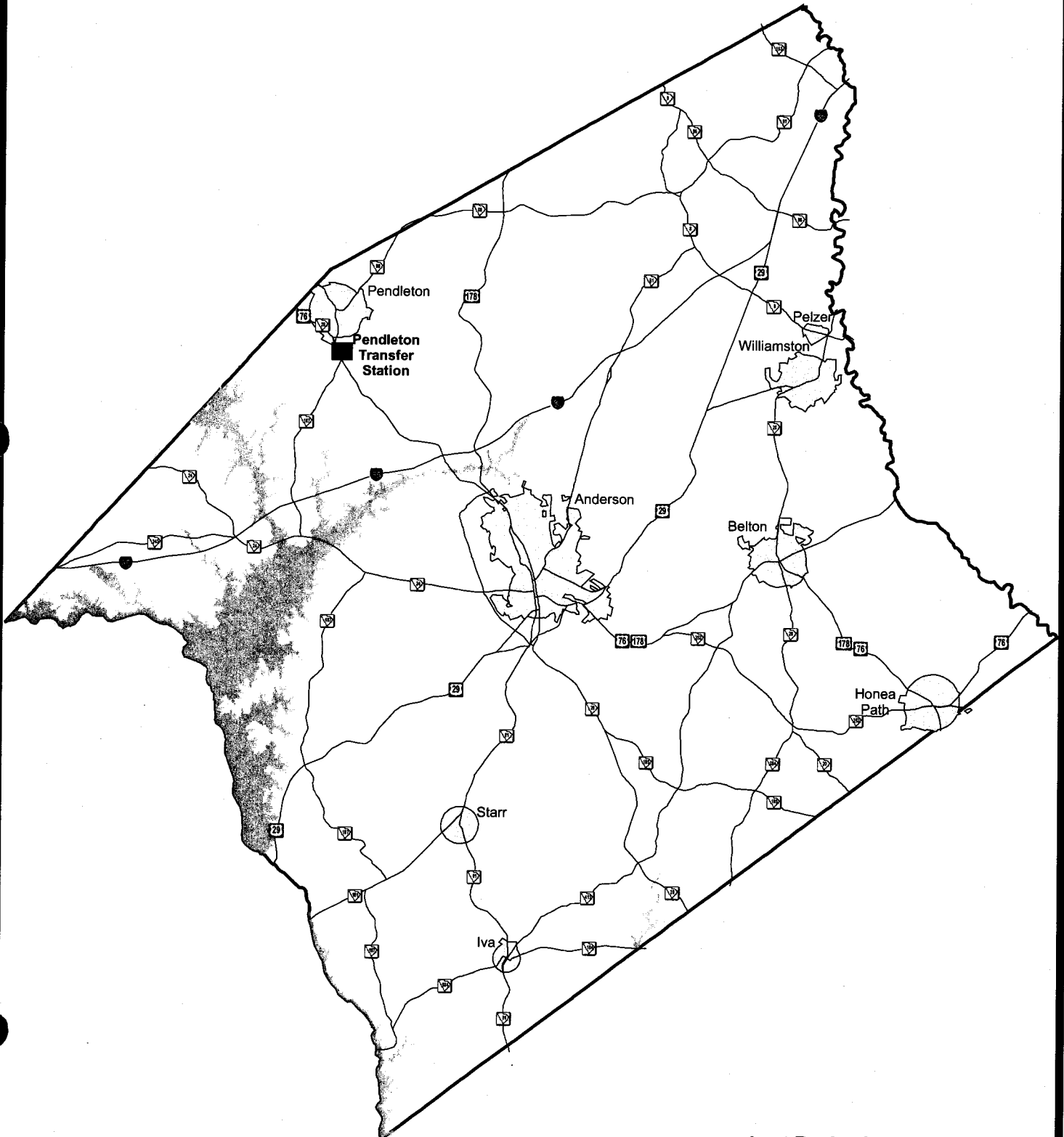

**Last Revised: December 7, 2004**

**D. SOLID WASTE PROCESSING FACILITIES**

SCDHEC Solid Waste Management Regulation 61-107.6 establishes procedures, documentation, and other requirements which must be met for the proper operation and management of all solid waste processing facilities. Four (4) Materials Recovery Facilities (MRF) or Processing Facilities are currently in operation within Anderson County (Exhibit C).

**Anderson Regional Material Recovery Facility**

Anderson County currently owns and operates the Anderson Regional Material Recovery Facility (MRF) located off Rector Road, adjacent to the Anderson Regional Landfill near the City of Belton. The permit issued by SCDHEC for the facility, #041001-2002, has been deactivated since the facility no longer processes municipal solid waste. The Anderson Regional MRF is utilized only for the processing and bailing of recyclable materials brought by County or municipal personnel, private collection companies, or County residents.

The municipalities of Belton, Honea Path, Pendleton, and Williamston all utilize the MRF for regular curbside collection efforts. Recyclable materials are either picked up or transported to processing facilities. Any materials unfit for recycling are transported to adjacent Anderson Regional Landfill for disposal.

Standard operating hours for the Anderson Regional Material Recovery Facility are Monday-Friday from 7:30 a.m. to 4:30 p.m. This facility is funded by the Solid Waste fee assessed by the County for area citizens. For additional information on the Anderson Regional Materials Recovery Facility, contact:

**Mr. Greg Smith, Solid Waste Management Manager**

Anderson County Solid Waste and Recycling Department  
731 Michelin Boulevard  
Anderson, South Carolina 29626  
Telephone: (864) 260-1001  
Fax: (864) 260-1002  
E-Mail: [gdsmith@andersoncountysc.org](mailto:gdsmith@andersoncountysc.org)

**LEGEND**

Processing Facility



Material Recovery Facility



**ANDERSON COUNTY  
SOLID WASTE MANAGEMENT FACILITIES  
PROCESSING FACILITIES**



**EXHIBIT C**

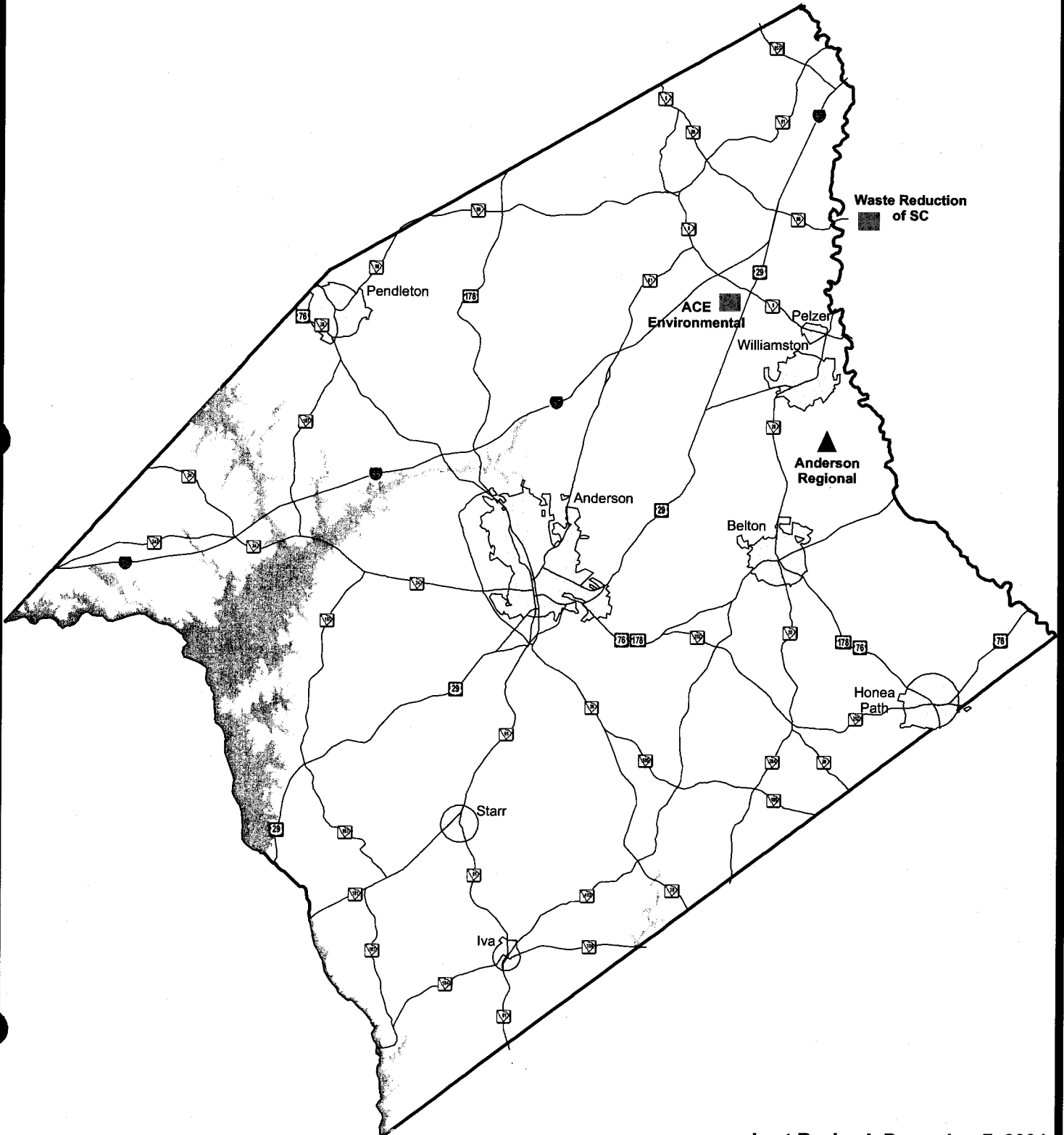

Last Revised: December 7, 2004



**ACE Environmental, Inc. Processing Facility**

ACE Environmental, Inc. owns and operates a Recycling Solid Waste Processing Facility (Facility ID Number (Fac. Id. #) 042663-2001) located as 508 Cherokee Road in the Town of Pelzer. From the City of Anderson, take Highway 81 North and turn right onto Hopewell Road, and left onto Midway Road, then turn left on Cherokee Road. The processing facility is on the left. This facility processes approximately 10,000 tons of C&D debris per year from local construction and demolition contractors. Recyclable materials such as scrap metal and cardboard are removed and hauled to scrap dealers. Materials not recycled are transported to a properly permitted landfill facility for ultimate disposal. Normal operating hours for the facility are Monday through Friday from 7:30 a.m. to 4:00 p.m. For more information on the ACE Environmental, Inc. Processing Facility, contact:

Mr. Michael J. Philips  
ACE Environmental, Inc.  
508 Cherokee Road  
Pelzer, South Carolina 29669  
Telephone: (864) 947-8100

**Waste Reduction of SC, Inc. Processing Facility**

The Waste Reduction of SC Processing Facility (SCDHEC #232687-2001) is another privately operated solid waste processing facility serving Anderson County residents; however this facility is located within Greenville County along the Anderson County border. This facility is located off Estes Plant Road in neighboring Piedmont, South Carolina. Although this processing facility is not located within Anderson County; because of its proximity and accessibility to Anderson County residents, it has been included within the Plan. The facility processes C&D debris from Anderson County and surrounding areas. For more information on the Waste Reduction of SC, Inc. Processing Facility, contact:

Mr. Gary Seymore  
Waste Reduction of SC, Inc.  
Post Office Box 1052  
Piedmont, South Carolina 29673  
Telephone: (864) 269-3548

**Waste Industries, Inc. Material Recovery Facility**

Waste Industries, Inc. owns and operates a MRF near the community of Powdersville in Anderson County. This facility does not process municipal solid waste, and is therefore not required to acquire an SCDHEC permit for operation.

**E. MUNICIPAL SOLID WASTE (MSW) LANDFILLS**

Municipal solid waste landfills may receive household waste, commercial solid waste, non-hazardous sludge, conditionally exempt small quantity generator waste, and industrial solid waste. SCDHEC Regulation 61-107.258 applies to landfills for the disposal of municipal solid waste. This regulation establishes the minimum criteria for construction and operation of a municipal solid waste, federal regulation Subtitle D compliant landfill. Within Anderson County there are two (2) closed MSW Landfills and one (1) operational facility (Exhibit D).

**Anderson Regional Subtitle D Landfill**

Anderson Regional Landfill, LLC, a wholly owned subsidiary of Allied Waste Industries, Inc., owns and operates the Anderson Regional Landfill under Fac. Id. # 042651-1101 (formerly 041001-1102 and DWP-046). This facility, located on Rector Road near the City of Belton, accepts non-hazardous municipal waste from households, business, industries, and commercial developments. The Anderson Regional Landfill is compliant with the US EPA Subtitle D regulations for Municipal Solid Waste Landfills. All businesses, industries, and commercial establishments require permits from

**LEGEND**

MSW Landfill (Active)



MSW Landfill (Closed)



**ANDERSON COUNTY  
SOLID WASTE MANAGEMENT FACILITIES  
MSW LANDFILLS**



**EXHIBIT D**

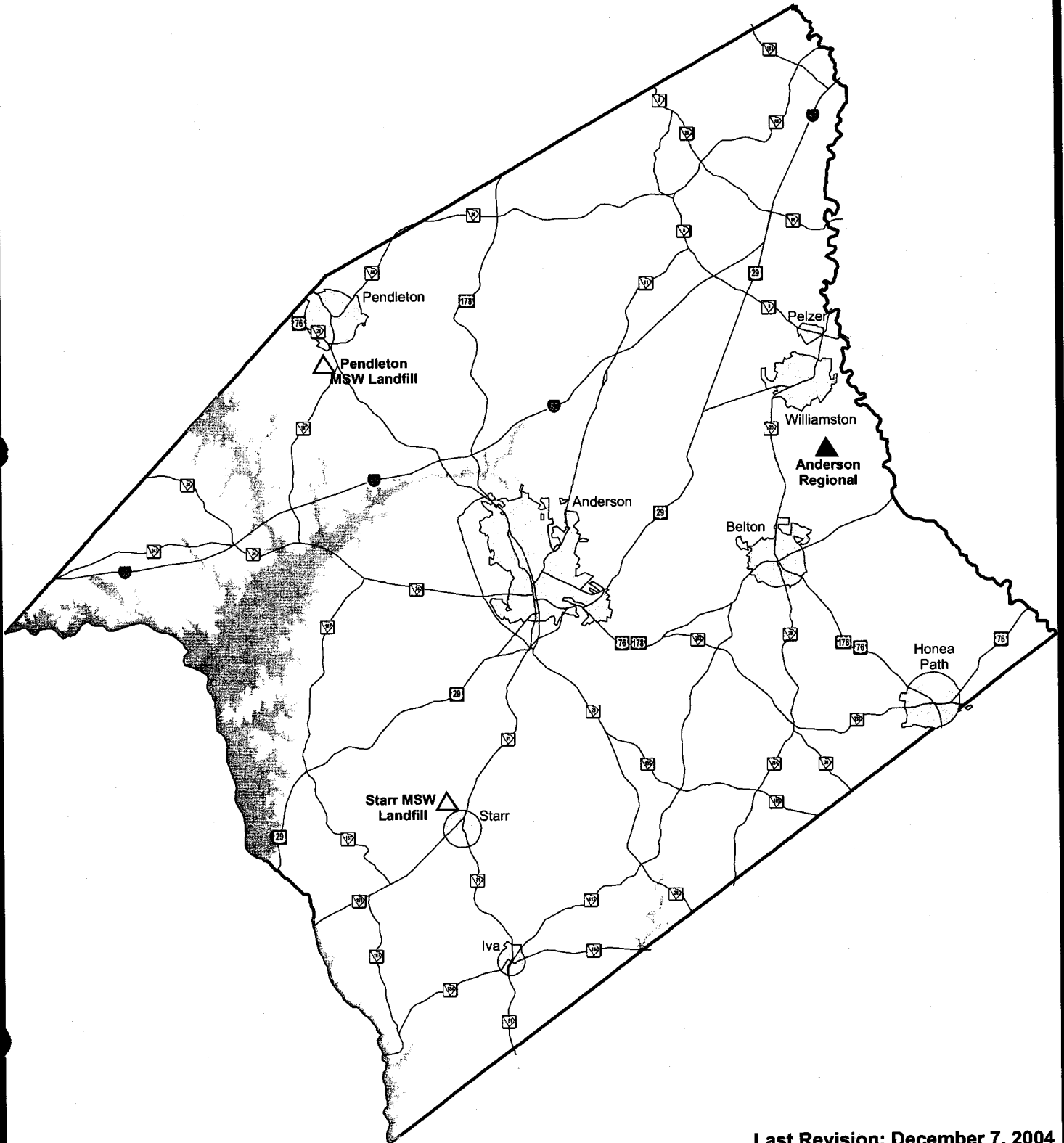

**Last Revision: December 7, 2004**

Anderson County

Anderson Regional Landfill, LLC to dispose of solid waste at the facility. No waste tires, lead acid batteries, or used oil are permitted for disposal at the Anderson Regional Landfill. The predetermined operating hours for the facility are 6:30 a.m. to 4:30 p.m. Monday through Friday, and 7:30 a.m. to 12:00 p.m. on Saturdays. The actual operational hours vary marginally in accordance with daily demands.

The Anderson Regional Landfill has an approximate life expectancy of more than twenty (20) years, at the maximum waste stream outlined in the aforementioned SCDHEC Permit. According to the SCDHEC 2003 Solid Waste Management Annual Report, the facility disposed of a combined total of 152,187 tons of MSW from the Counties of Anderson and Greenville. Estimates reported in 2004 indicate an increase in disposal rates to approximately 314,000 tons annually. Disposal rates below the maximum permitted limit will increase the life expectancy of this facility. Anderson Regional Landfill, LLC is obligated by contract to provide Anderson County disposal capacity for twenty (20) years; however, Anderson County is not obligated to use the landfill for disposal.

The groundwater monitoring network, required by R.61-107.258, consists of twelve (12) groundwater monitoring wells located throughout the Anderson Regional Landfill. These wells are sampled semi-annually for Appendix I constituents. The facility is also equipped with an active methane gas removal system. This system extracts methane gas from the landfill using a network of pumps. Anderson Regional Landfill, LLC (ARL), has entered a Landfill Gas Beneficial Use Agreement with the South Carolina Public Service Authority (Santee Cooper). This agreement began on September 10, 2003 and terminates on August 31, 2024. Under this agreement Santee Cooper will install and operate a Power Plant to utilize the methane gas produced at ARL.

For additional information on the Anderson Regional Landfill, contact:

Mr. Randy Hovis, Landfill Manager  
Anderson Regional Landfill, LLC  
Post Office Box 519  
Belton, South Carolina 29627  
Telephone: (843) 338-1815

**Anderson County Starr MSW Landfill**

The County owns a closed municipal solid waste landfill off SC Highway 81 near the Town of Starr. The Starr MSW Landfill (Permit No. 041001-1101) consisting of approximately sixty-eight (68) acres, ceased accepting waste on September 3, 1993. The landfill is currently in the thirty (30)-year post-closure care period, including both groundwater and methane gas monitoring. The groundwater monitoring network consists of fifteen (15) groundwater monitoring wells located around the perimeter of the landfill. These wells are monitored and reported to SCDHEC on a semi-annual basis. The gas monitoring network consists of thirteen (13) gas monitoring probes, which are monitored on a bi-weekly basis. Additionally thirty-eight (38) passive gas vents are located along the boundary of the existing methane remediation area. For additional information on the Anderson County Starr MSW Landfill, contact:

Mr. David Scott, P.E., Environmental Engineering Manager  
Anderson County Environmental Services Division  
713 Michelin Boulevard  
Anderson, South Carolina 29626  
Telephone: (864) 260-1001  
Facsimile: (864) 260-1002  
E-Mail: dscott@andersoncountysc.org

**Anderson County Pendleton MSW Landfill**

The County also owns a second closed municipal solid waste landfill off US Highway 76 in the Town of Pendleton. The Pendleton MSW Landfill previously operated under Fac. Id. # DWP-115, but closed on September 1, 1993 and no longer receives any type of waste. The approximately twenty-five

Anderson County

(25)-acre site is currently in the thirty (30)-year post-closure care period. As required by SCDHEC regulations, the facility undergoes semi-annual groundwater monitoring and quarterly methane monitoring. The existing groundwater monitoring network consists of eight (8) groundwater monitoring wells. The gas monitoring network consists of nine (9) gas monitoring probes in combination with twenty-six (26) passive gas vents. For additional information on the Anderson County Pendleton MSW Landfill, contact:

Mr. David Scott, P.E., Environmental Engineering Manager  
Anderson County Environmental Services Division  
713 Michelin Boulevard  
Anderson, South Carolina 29626  
Telephone: (864) 260-1001  
Facsimile: (864) 260-1002  
E-Mail: [dscott@andersoncountysc.org](mailto:dscott@andersoncountysc.org)

**F. SLUDGE MONOFILLS**

Sludge monofills are facilities which accept any solid, semi-solid, or liquid waste generated from a municipal, commercial, or industrial wastewater treatment plan, potable water treatment plant, or air pollution control facility exclusive of the treated effluent from a wastewater treatment plant. These facilities are generally on a discrete area of land or an excavation that is not a land application unit, surface water impoundment, injection well, or waste pile. There are currently no sludge monofills located within Anderson County.

**G. INCINERATOR ASH MONOFILLS**

Incinerator ash monofills are facilities which accept the solid residue from the incineration of solid waste. These facilities, regulated by SCDHEC Regulation 61-107.13, are typically located on a discrete parcel of land on an excavated area that is not a land application unit, surface water impoundment, injection well, or waste pile. There are currently no incinerator ash monofills located within Anderson County.

**H. CONSTRUCTION, DEMOLITION, & LAND-CLEARING DEBRIS (C&D)**

**LANDFILLS**

Construction, Demolition, and Land-Clearing Debris (C&D) Landfills are governed by SCDHEC Solid Waste Regulation 61-107.11. This regulation establishes minimum standards for the site selection, design, operation, and closure of C&D landfills. C&D landfills are classified as Part I, Part II, Part III, or Part IV landfills. Waste suitable for disposal in these facilities include solid waste discarded during construction, remodeling, repair and demolition of structures, road-building, and land-clearing. This waste includes, but is not limited to, bricks, concrete, masonry materials, soil, rock, lumber, road spoils, paving materials, and tree stumps. Solid waste from agricultural or silvicultural operations are not included within the allowable materials. According to SCDHEC's 2003 Solid Waste Management Annual Report, approximately 52,247 tons of C&D debris was generated for disposal within Anderson County. Exhibit E shows C&D Landfills within Anderson County.

**1. Part I (Short-Term) C&D Landfills**

Part I C&D Landfills are small, short-term facilities to be used for structural fill, with a limited waste stream, and with a specified facility life. The operational life of a Part I C&D landfill cannot exceed twelve (12) months and the land area may not exceed one (1) acre. The only materials allowed for disposal in these facilities are land-clearing debris, hardened concrete, cured asphalt, bricks, and blocks that have not been in contact with hazardous constituents. Currently there are no operational Part I C&Ds within Anderson County.

**LEGEND**

C&D Landfill (Part II)



C&D Landfill (Part IV)



**ANDERSON COUNTY  
SOLID WASTE MANAGEMENT FACILITIES  
C&D LANDFILLS**



**EXHIBIT E**

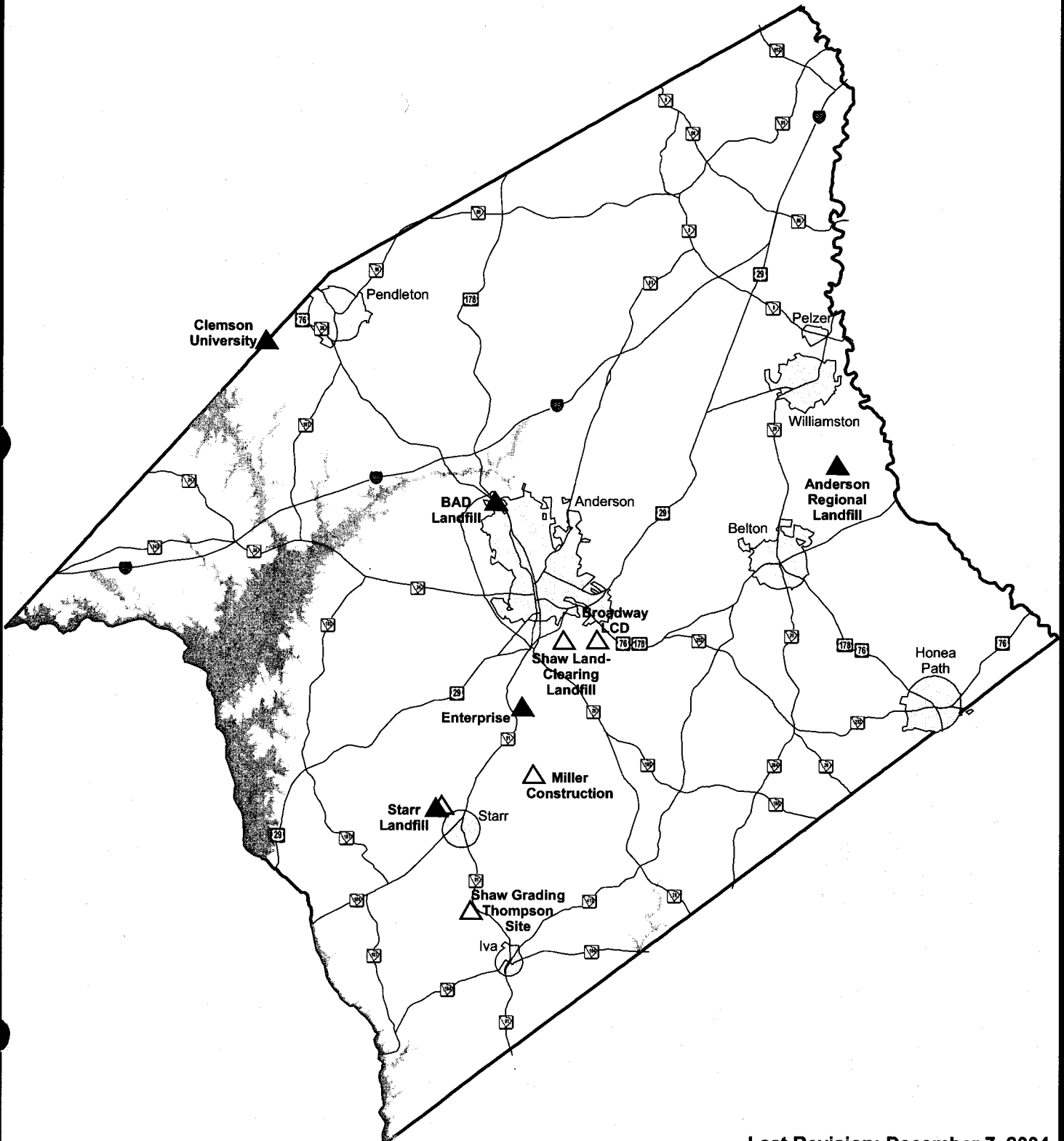

Last Revision: December 7, 2004



2. **Part II-General Permits for Land-Clearing & Yard Trash**

Part II of the SCDHEC C&D Landfill Regulations outlines the General Permitting Requirements for the disposal of trees, stumps, woodchips, i.e., land-clearing debris, and yard trash to be used for structural fill. Facilities meeting the requirements set forth in this regulation are classified as Part II C&D Landfills. Facilities successfully fulfilling the requirements of a Part II C&D landfill will be covered under a Statewide General Permit. Five (5) Part II Landfills are currently permitted within Anderson County.

**Shaw Grading – Thompson Land-Clearing Debris & Yard Trash Landfill**

Mr. Gary Shaw owns and operates the Shaw Grading Thompson Site Land Clearing-Debris Landfill (Permit No. 042698-1701) on Whit Chamblee Road approximately two (2) miles south of the Town of Starr on SC Highway 81. The Part II C&D Landfill is less than one (1) acre in size and is utilized by Mr. Shaw for the disposal of land-clearing debris generated by his privately owned construction business. The landfill is not open to the public. For additional information on the Shaw Grading – Thompson Site Landfill, contact:

Mr. Gary Shaw  
Shaw Grading  
850 Rainey Road  
Starr, South Carolina 29684  
Telephone: (864) 352-6707

**Shaw Land-Clearing & Yard Trash Landfill**

Mr. George Shaw owns and operates the Shaw Land-Clearing Debris and Yard Trash Landfill under Fac. Id. # 042637-1701. This facility is located off McFalls Circle south of the City of Anderson. The facility disposes of yard debris from local contractors.

Anderson County

For additional information on the Shaw Land-Clearing Debris and Yard Trash Landfill, contact:

Mr. George Shaw  
Shaw Land-Clearing Debris and Yard Trash Landfill  
118 McFalls Circle  
Anderson, South Carolina 29621  
Telephone: (864) 296-0000

**Miller Construction Company Site #5 Land-Clearing Debris & Yard Trash Landfill**

Miller Construction Company owns and operates a Land-Clearing Debris & Yard Trash Landfill (Permit No. 042689-1702) at the Roger J. Slaton Site. The facility has a limited capacity of approximately 60,000 cubic yards (CY) and accepts approximately 15,000 CY of debris each year from Miller Construction Company, the sole source of material. Therefore, the life expectancy of the facility is restricted to one (1) or two (2) remaining years. For additional information on the Miller Construction Company Land-Clearing Debris & Yard Trash Landfill, contact:

Mr. Mike Miller  
Miller Construction Company  
225 Thompson Road  
Anderson, South Carolina 29624  
Telephone: (864) 296-3301

**Broadway Land-Clearing Debris Landfill**

The Broadway Land-Clearing Debris Landfill is a privately owned and operated Part II C&D Landfill under Fac. Id. # 042722-1701. This facility, located near the community of Broadway just south of the City of Anderson, disposes of mainly commercially generated land-clearing debris and yard trash generated by construction activities associated with the owner of the facility

**Starr Land-Clearing & Yard Trash Landfill**

Anderson County recently received Permit No. 041001-1701 allowing for the construction and operation of the approximately eighteen (18) acre Starr Land-Clearing and Yard Trash Landfill. The facility is located adjacent to the existing Starr MSW and C&D Landfills. The facility, open from 7:30 a.m. to 12:00 p.m. on Saturdays, is permitted to accept 26,400 CY of land-clearing debris and yard trash from County residents and local businesses. The landfill began the placement of yard trash and land-clearing debris in the facility in July 2004. The life expectancy of the Starr Land-Clearing and Yard Trash Landfill is ten (10) to fifteen (15) years. For additional information on the Starr Land-Clearing and Yard Trash Landfill, contact:

Mr. Greg Smith, Solid Waste Management Manager  
Anderson County Solid Waste and Recycling Department  
731 Michelin Boulevard  
Anderson, South Carolina 29626  
Telephone: (864) 260-1001  
Fax: (864) 260-1002  
E-Mail: [gdsmith@andersoncountysc.org](mailto:gdsmith@andersoncountysc.org)

**3. Part III C&D Landfills**

Part III C&D Landfills are those facilities accepting construction, demolition, and land-clearing debris associated with permanent industrial establishment. Part III of *R61-107.11* outlines the permit-by-rule requirements for the disposal of approved materials when the facility has controlled access and serves a permanently located utility facility or manufacturing firm, such as those listed in the South Carolina Industrial Directory. There are currently no Part III C&D landfills in operation within Anderson County.



**4. Part IV C&D Landfills**

The final classification, Part IV, for C&D Landfills encompasses all C&D Landfills not addressed in Part I, II, or III. There are four (4) of these long-term facilities currently in operation within Anderson County.

**Clemson University C&D Landfill**

Clemson University owns and operates a Part IV C&D Landfill (Permit No. 041804-1202) off Fants Grove Road on the campus of the University. The facility accepts approximately 500 tons of C&D debris annually as generated by the University. For additional information on the Clemson University C&D Landfill, contact:

Mr. Andy Anderson  
Clemson University  
Klugh Avenue  
Clemson, South Carolina 29634-5901  
Telephone: (864) 656-4940

**BAD C&D Landfill**

The Bobby and Danny (BAD) C&D Landfill is a privately owned and operated Part IV C&D Landfill located off McGhee Road, north of the City of Anderson off of US 76 in Anderson County. The facility (Permit No. 042629-1201) is approximately five (5) acres in size and accepts C&D Debris from land-clearing contractors. The facility charges a tipping fee of \$25.00 per ton for disposal. For additional information on the BAD C&D Landfill, contact:

Mr. Danny Standard  
BAD C&D and LCD Landfill  
416 McGhee Road  
Anderson, South Carolina 29625  
Telephone: (864) 225-5962

**Anderson County Starr C&D Landfill**

Anderson County owns and operates a Part IV C&D Landfill near the Town of Starr. The landfill, located off SC Highway 81 on Roy Arnold Road, operates under Fac. Id. # 041001-1701 (July 19, 2004). The C&D landfill is open Monday through Friday from 7:30 a.m. to 4:30 p.m. and Saturdays from 7:30 a.m. until 12:00 p.m. The approximately 230 acre facility is available to the public for the disposal of all permitted C&D debris including non-friable asbestos. Approximately 33,000 tons of C&D debris are deposited annually by Anderson County residents and commercial entities. The current permit allows for the disposal of 43,300 CY C&D debris annually. The existing facility is scheduled for closure on October 31, 2004 and the recently permitted expansion facility will then begin operation under similar requirements. The County assesses a tipping fee for disposal; the remainder of the operation is funded by the collection of a Solid Waste Fee assessed by the County. For additional information on the Starr C&D Landfill, contact:

Mr. Greg Smith, Solid Waste Management Manager  
Anderson County Solid Waste and Recycling Department  
731 Michelin Boulevard  
Anderson, South Carolina 29626  
Telephone: (864) 260-1001  
Fax: (864) 260-1002  
E-Mail: [gdsmith@andersoncountysc.org](mailto:gdsmith@andersoncountysc.org)

**Enterprise Material Handling C&D Landfill**

The Enterprise Material Handling C&D Landfill is a privately owned solid waste management facility (Permit No. 042733-1201, October 5, 2004). This facility began operation in the fall of 2004. For additional information on the Enterprise Material Handling C&D Landfill, contact:

Mr. Michael Phillips  
Enterprise Material Handling C&D Landfill  
Post Office Box 13436  
Anderson, South Carolina 29624  
Telephone: (864) 225-7116

**Big Creek C&D Landfill**

The Big Creek Landfill previously operated under, Permit No. 041001-1202. This facility is located at Big Creek Road near Belton and was previously owned and operated by Anderson County. However, this facility was discontinued when ownership of the facility was transferred to Anderson Regional Landfill, LLC. The Anderson Regional Permit allows Anderson Regional Landfill, LLC to place C&D materials into the MSW facility. This facility inherited all operational aspects of the Anderson Regional Landfill.

**Anderson Regional Landfill C&D Landfill**

The Anderson Regional Landfill, LLC owns a C&D landfill facility located at Big Creek Road near Belton. The facility, no longer in operation, was closed to accommodate a vertical expansion of the MSW landfill at the same location. For additional information on the closed Anderson Regional C&D Landfill, contact:

Mr. Randy Hovis, Landfill Manager  
Anderson Regional Landfill, LLC  
Post Office Box 159  
Belton, South Carolina 29627  
Telephone: (843) 338-1815

**I. INDUSTRIAL SOLID WASTE (ISW) LANDFILLS**

SCDHEC Solid Waste Management Regulation 61-107.16 establishes minimum criteria for all industrial solid waste (ISW) Landfill facilities. ISW landfills are

facilities for the permanent disposal of non-hazardous wastes generated by manufacturing or industrial processes. Under *R 61-107.16* there are three (3) classifications of ISW Landfills.

**1. Class 1 ISW Landfills**

Class 1 ISW landfills are facilities that dispose of non-hazardous wastes that test less than or equal to ten (10) times the Maximum Contaminant Level (MCL) published in the SCDHEC *R. 61-58*, State Primary Drinking Water Regulations. There is currently one (1) Class 1 ISW landfill operating within Anderson County (Exhibit F).

**Owens Corning Fiberglass ISW Landfill**

The Owens Corning Fiberglass Corporation owns and operates a Class 1 ISW Landfill under Fac. Id. # 043334-1601 (formerly IWP-015 and IWP-0240). This facility, located on Hayes Road south of the City of Anderson, accepts only wastes generated at the Owens Corning Fiberglass Plant. For more information on the Owens Corning ISW Landfill, contact:

Mr. Steve Tenry  
Owens Corning Fiberglass Corporation  
Post Office Box 1367  
Anderson, South Carolina 29622  
Telephone: (864) 296-4075



**LEGEND**

ISW Landfill



**ANDERSON COUNTY  
SOLID WASTE MANAGEMENT FACILITIES  
ISW LANDFILLS**



**EXHIBIT F**

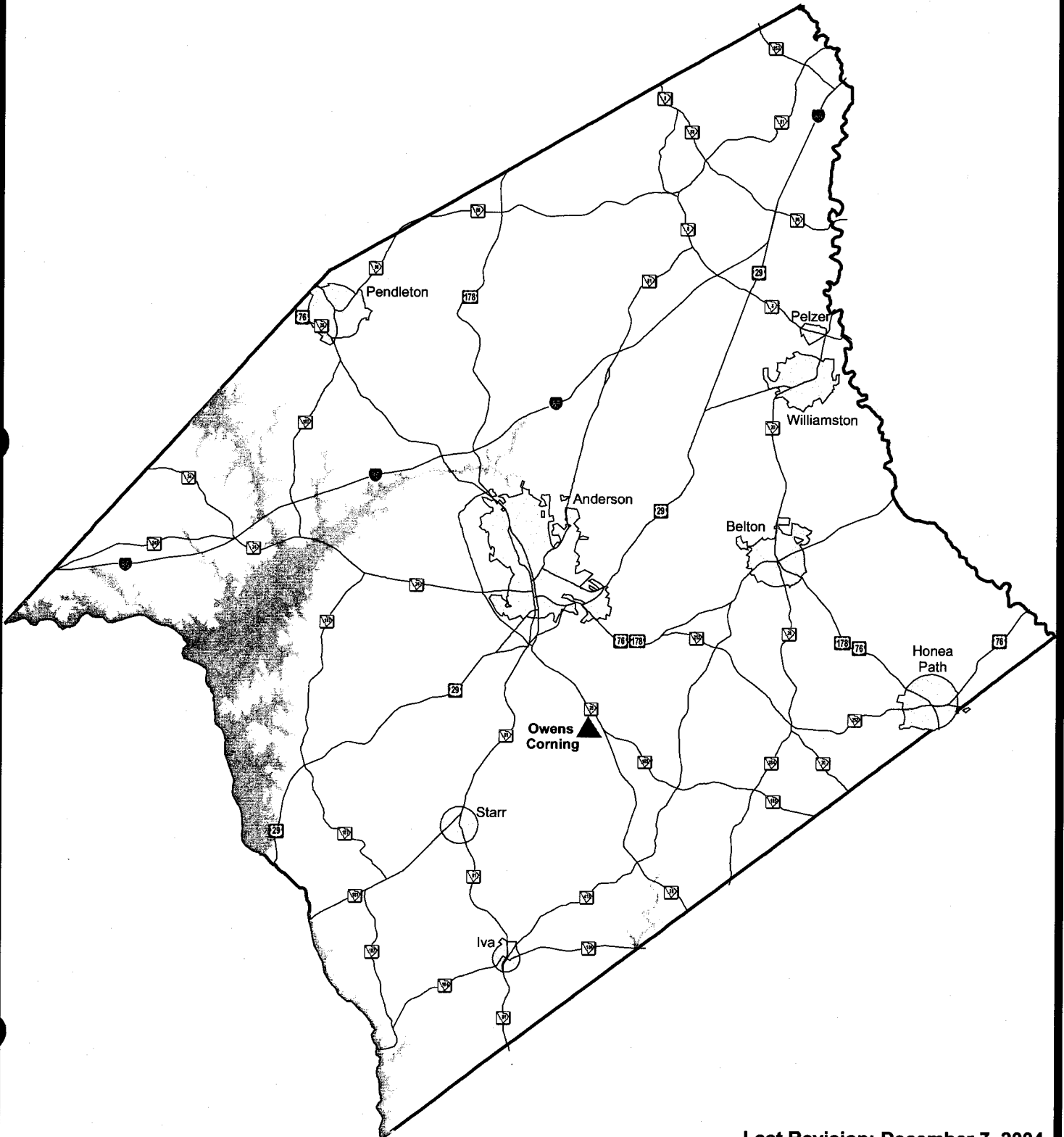

Last Revision: December 7, 2004

**2. Class 2 ISW Landfills**

Class 2 ISW Landfills are facilities that dispose of non-hazardous wastes that test greater than ten (10) times the MCL but less than or equal to thirty (30) times the MCL as published in the SCDHEC R 61-58, State Primary Drinking Water Regulations. There are currently no Class 2 ISW landfills operating within Anderson County.

**3. Class 3 ISW Landfills**

Class 3 ISW Landfills are facilities that dispose of non-hazardous wastes that are not suitable for classification in either Class 1 or Class 2 ISW landfills. There are currently no Class 3 ISW landfills operating within Anderson County.

**J. MUNICIPAL SOLID WASTE INCINERATORS**

Municipal Solid Waste Incinerators are those publicly or privately owned facilities that receive household solid waste for the purpose of incineration. Such facilities may receive other wastes such as commercial and/or industrial wastes. There are no Municipal Solid Waste Incinerators in Anderson County.

**K. COMPOSTING AND WOOD CHIPPING/SHREDDING FACILITIES**

Composting and Wood Chipping Facilities are those facilities that accept land-clearing debris and yard trash for the purpose of producing compost and/or other beneficial vegetative goods (i.e., mulch, woodchips). SCDHEC Regulation 61-107.4 outlines the proper disposal and management of yard trash from residential, commercial or industrial property. SCDHEC encourages such facilities for the production and use of compost. Currently there are three (3) operational Composting facilities located within Anderson County (Exhibit G).

**LEGEND**

Composting Facility



**ANDERSON COUNTY  
SOLID WASTE MANAGEMENT FACILITIES  
COMPOSTING FACILITIES**



**EXHIBIT G**

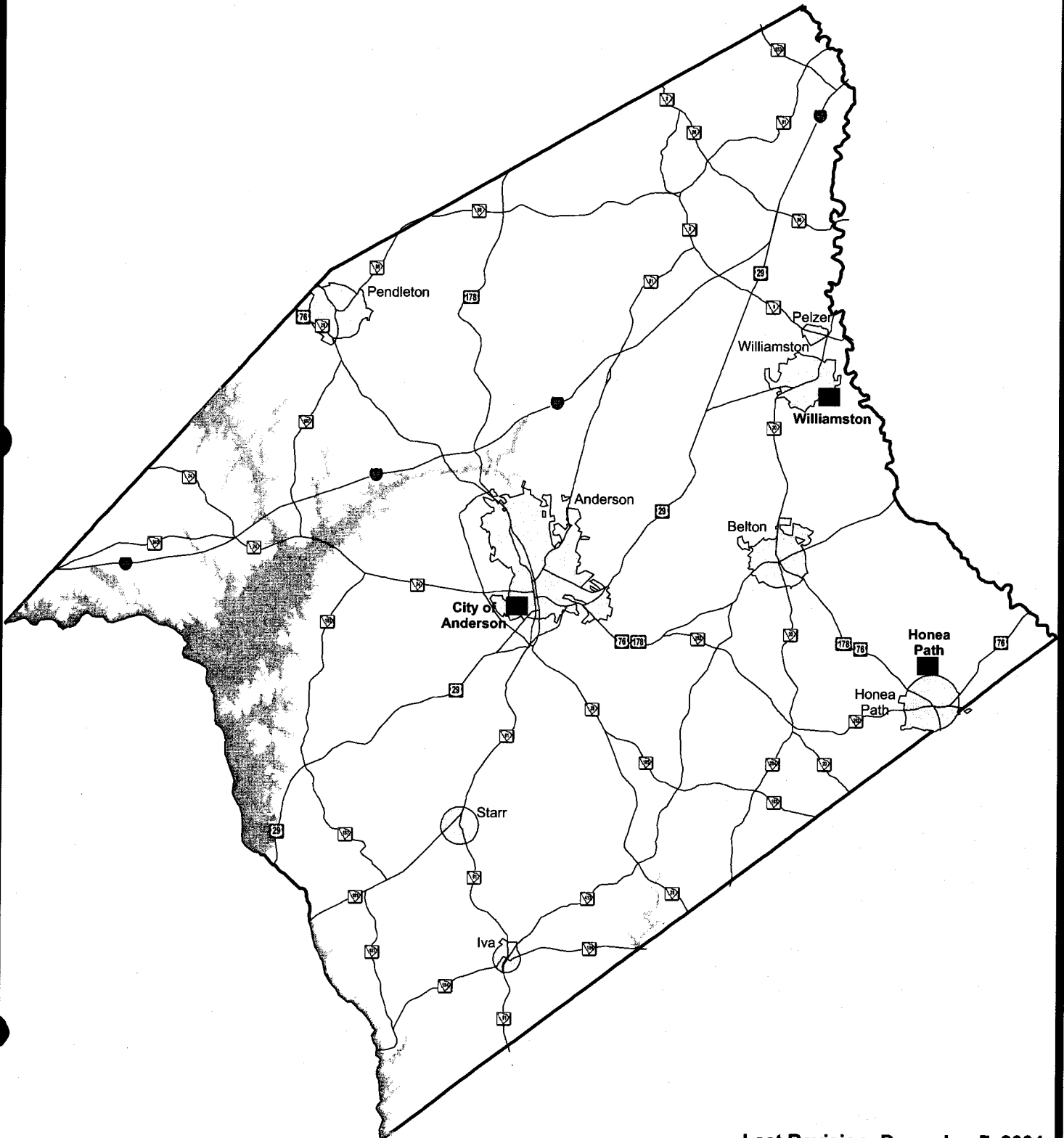

Last Revision: December 7, 2004

**City of Anderson Composting Facility**

The City of Anderson owns and operates the City of Anderson Composting/Wood Chipping Facility located at 1100 Southwood Street. The facility, Permit No. 041003-3001, accepts locally generated yard debris from City residents only. The City's facility has operated primarily as a wood-chipping operation; however, the facility is currently being decommissioned. For more information on the City of Anderson Composting Facility, contact:

Mr. Ronnie Aderhold, Sanitation Supervisor  
City of Anderson Public Works Department  
Telephone: (864) 231-2796  
Facsimile: (864) 231-7936  
Website: <http://www.cityofandersonsc.com>

**Town of Honea Path Composting Facility**

The Town of Honea Path owns and operates a Composting Facility under Permit No. 041002-3001. The facility, located off Holiday Dam Road, receives yard trash collected by the Town's solid waste collection personnel. The site is approximately sixteen (16) acres and receives approximately eighty (80) tons of debris annually from curbside collection activities. Typical operating hours are Monday through Friday from 7:00 a.m. to 4:00 p.m. For additional information on the Town of Honea Path's Composting Facility, contact:

Mr. Thomas Brock, Director  
Town of Honea Path Public Works Department  
30 North Main Street  
Honea Path, South Carolina 29654-1516  
Telephone: (864) 369-7467 or (864) 369-2325  
Facsimile: (864) 369-0580

**Town of Williamston Composting Facility**

The Town of Williamston owns and operates the Town of Williamston Composting Facility off Mill Street. The facility, Permit No. 041004-3001, accepts yard debris from Town of Williamston residents and functions primarily

as a wood chipping operation. Woody debris is chipped using a stationary wood chipper. The facility accepts approximately sixty (60) tons of yard debris annually. Hours of operation for this Town of Williamston Composting Facility are Monday through Friday 7:00 a.m. to 4:00 p.m. This service is funded by annual property taxes assessed to Town of Williamson citizens. For additional information on the Town of Williamston Composting Facility, contact:

Mr. David Roberts, Streets Supervisor  
Town of Williamston  
Post Office Box 70  
Williamston, South Carolina 29697  
Telephone: (864) 847-7473

**L. USED OIL COLLECTION & PROCESSING FACILITIES**

Used Oil is collected at the convenience centers located throughout Anderson County. The oil collected at the convenience centers is held in approved containers provided by Santee Cooper. Anderson County personnel notify Santee Cooper when the containers are ready for transport to a processing facility outside of the County. No used oil processing facilities are currently located within the County. In addition to the convenience centers, used oil is also collected at the following locations:

**City of Anderson**

- Advance Auto, 915 28 Bypass
- Advance Auto, 2849 South Main Street (Sky City Shopping Center)
- Advance Auto, 3507 Clemson Boulevard
- Auto Zone, 848 Highway 28 Bypass
- Auto Zone, 1402 East River Street
- Jiffy Lube, 1404 North Main Street

**City of Belton**

- Advance Auto, 416 South Main Street

**Town of Pelzer**

- Advance Auto, 113 Highway 20

**Town of Pendleton**

- Advance Auto, 7703 Highway 76

**Town of Williamston**

- Big Creek Landfill, Rector Road

**New Prospect Community**

- Echo Circle off Old Green Pond Road (also accepts filters and bottles)

**M. WASTE TIRE FACILITY PERMITS**

SCDHEC Regulation 61-107.3 outlines the requirements of facilities that handle waste tires, including waste tire haulers, collectors, processors and disposers. There are two (2) such facilities currently located within Anderson County. Additionally, SCDHEC approved an operational permit for Upstate Junk Processing, Inc. on July 20, 2004.

**Anderson Tire Recycling, Site No. 1 (Permit No. 042417-5201)**

**Anderson Tire Waste Tire Disposal Facility (Permit No. 042417-5301)**

Anderson Tire Recycling owns and operates a waste tire processing facility and a waste tire disposal facility at 3520 Abbeville Highway in the City of Anderson. This privately owned facility accepts residential and commercial waste tires for recycling, processing, and/or disposal. The fees associated with Anderson Tire Recycling are based on fluctuating market values and are subject to change. For additional information on either Anderson Tire Recycling or Anderson Tire Waste Tire Disposal, contact:

Mr. Doug Proctor  
Anderson Tire  
3520 Abbeville Highway  
Anderson, South Carolina 29624  
Telephone: (864) 296-8638

None of the Anderson County convenience centers accept waste tires; however, waste tires can be dropped off at the Anderson Regional Materials Recovery Facility. All tires collected at the MRF are transported to a certified waste tire disposal facility for processing.

**N. RESEARCH, DEVELOPMENT, & DEMONSTRATION (RD&D) PERMITS**

Research, Development and Demonstration (RD&D) permits are issued for innovative, experimental solid waste management technologies and processes. Requirements for these facilities are outlined in SCDHEC Regulation 61-107.10. No RD&D permits have been issued by SCDHEC for solid waste facilities within Anderson County.

**O. LAND APPLICATION OF SOLID WASTE PERMITS**

Permits for the land application of solid waste establishes application rates, frequency of application, and monitoring of requirements for the uniform surface spreading or mechanical incorporation of non-hazardous wastes onto or into soil that is being used for agricultural, silvicultural and horticultural production as outlined in SCDHEC Regulation 61-107.15. The land application of solid waste is a way to recycle South Carolina's resources and is not a means of disposal. This does not include the land application of solid or dissolved material in domestic sewage, industrial sludges, or water treatment sludge. No permits or the land application of solid waste have been issued by SCDHEC for sites located within Anderson County.

**P. RECYCLING PROGRAMS**

Recycling is a key component of Anderson County's Solid Waste Management System. The County expects to continue reducing the volume of solid waste that would otherwise be land filled.

Anderson County

The County is committed to meeting the goals established in the Act, as amended, of achieving a recycling rate of at least 35%, by weight, of the municipal solid waste stream within the County by June 30, 2005. In 2003, Anderson County reported an MSW recycling rate of approximately 21%.

To meet the goal set by SCDHEC, the County will require continued investment to improve recycling collection facilities, expanding the types of materials accepted for recycling as new markets develop, greater residential commitment to utilizing the recycling opportunities offered the County and its municipalities, encouraging private waste haulers to incorporate recycling into their collection services, and expanding education efforts.

It is the goal of the County recycling program to have all segments of the community committed to, and actively participating in, recycling efforts. This includes not only private citizens, but also government offices, schools, commercial businesses, industries, private haulers, and community organizations.

The County's drop-off convenience centers are the backbone of the County's recycling collection system. Each of the convenience centers has specially marked bins and containers to accept recyclables. A special municipal-county partnership was initiated in 2000 and has since expanded the County collection efforts to include curbside collection in the four (4) municipalities of the City of Belton, and the Towns of Honea Path, Pendleton, and Williamston.

The types of materials collected by the County for recycling are driven by market forces. The County is only able to collect those materials for which recycling markets currently exist. Anderson County utilized various recycling brokers depending on price and preparation restrictions.



Under current market conditions, the County is able to successfully collect and arrange for recycling of the following materials:

**Aluminum & Steel Cans**

Aluminum and steel cans are collected at all convenience centers and through municipal curbside recycling programs. The cans are bailed at the Anderson Regional Materials Recovery Facility. When a significant quantity is obtained, a recycling company is contacted to transport the materials to a processing facility.

**Plastics #1 & #2**

Plastics denoted with a #1 or #2 symbol are collected at all the convenience centers and through the municipal curbside recycling programs. Collected materials are brought to the Anderson Regional Materials Recovery Facility. When a significant quantity is obtained, a recycling company is contacted to transport the materials to a processing facility.

**Glass- Brown, Green, & Clear**

Brown, green and clear glass bottles and jars are collected at all convenience centers and through the municipal curbside recycling programs. Collected materials are transported to the White Street Transfer Station facility and deposited in specially built glass collection containers. When a significant quantity is obtained, a recycling company is contacted to transport the materials to a processing facility.

**Mixed Paper**

Paper products, such as brown paper bags, cardboards, magazines, catalogs, newspapers, and office paper, are collected at all convenience centers and through the municipal curbside recycling programs. Collected materials are brought to the Anderson Regional Materials Recovery Facility. When a significant quantity is obtained, a recycling company is contacted to transport the materials to a processing facility.

**Corrugated Cardboard**

Corrugated cardboard is collected at all convenience centers and through the municipal curbside recycling programs. Collected materials are brought to the Anderson Regional Materials Recovery Facility or taken directly to Paper Stock. When a significant quantity is obtained, a company is contacted to transport the materials to a processing facility.

**Used Oil**

As previously mentioned, used oil is collected at all convenience centers in special tanks provided by Santee Cooper's Give Oil for Energy Recovery (GOFER) Program. When a significant quantity is obtained, Anderson County personnel contact Santee Cooper to transport the materials to a processing facility. Several automotive-related establishments throughout Anderson County also accept used oil for recycling.

**Used Oil Bottles & Filters**

In addition to used oil, used oil bottles and used oil filters are also accepted at the Anderson County convenience centers. The bottles and filters are transported to the Anderson Regional Materials Recovery Facility. Once a significant amount of material has been accumulated, a recycling organization is contacted to collect the items.

**White Goods**

Provided the items don't contain Freon and/or other scrap metals, white goods are collected at the majority of the Anderson County convenience centers. A certified recycling dealer is contacted to transport the items from the collection sites to a certified recycling facility.

**Lead Acid Batteries**

Lead acid batteries are collected at all Anderson County convenience centers and transported to a local recycler for processing.

**Waste Tires**

As mentioned earlier, waste tires are only collected at the Anderson Regional Materials Recovery Facility. All waste tires collected are delivered to a certified used tire disposal facility for processing.

**Cellular Phones**

Cellular telephones are collected at all convenience centers. Collected items are taken to various wireless providers participating in the national Call to Protect program, redistributing cellular telephones to domestic abuse prevention programs throughout the United States.

**Ink Jet Cartridges**

Keep America Beautiful of Anderson County collects several types of ink jet cartridges and sends them to a processor.

**Plastic Bags**

Plastic bags (#4) may be recycled at participating local grocery stores and supermarkets.

**Scrap Metal**

Scrap metal is collected at the majority of the Anderson County convenience centers. Scrap metal is then transported to a local or regional recycling facility.

To expand recycling markets requires a commitment by government, industry, and the public to continually look for new products that can be made from recyclable materials and to buy recycled goods. The County has incorporated “buy recycled” into its County purchasing practices and has led by example in choosing to utilize recycled chipped rubber from waste tires to pave walking trails at the Anderson Sports and Entertainment Complex and by conducting a pilot paving project with Clemson University and the South Carolina Department of Transportation (SCDOT) utilizing rubberized asphaltic paving.

Currently, all recycling programs in the County are voluntary. To increase the amount of recycling, the County has been developing an aggressive education program. This program encompasses neighborhood, civic, school, and business presentations; public awareness campaigns using a variety of media outlets including billboards, newspaper ads, targeted flyers, and radio; recycling workshops; specialized theme events such as “Grinding of the Greens” and “America Recycles Day”; visual presence at a wide variety of community events, and the scheduling of ongoing events at the Recycling Education Center. For its efforts in recycling, Anderson County personnel won the 2003 Jack Hirst Recycling Coordinator of the Year Award and 2003 Best Waste Reduction Program from Keep America Beautiful, Inc.

The Recycling Education Center, located off Mall Road across from the Anderson Sports and Entertainment Center, was conceived by Anderson County to improve community awareness and communication in relation to recycling. The facility is adjacent to a manned recyclables-only drop-off site open seven days a week. The Education Center houses recycling exhibits and serves as a classroom and meeting facility. In addition, a covered pavilion serves as an outdoor classroom complete with several outdoor exhibits that have been developed with the assistance of area establishments such as Clemson University. Additional exhibits are being developed by Anderson County staff members and will be implemented as the Recycling Education Center develops further.

**Q. SPECIAL WASTES**

Special Waste is defined as nonresidential or commercial solid waste, other than regulated hazardous wastes, that is either difficult or dangerous to handle and requires unusual management at municipal solid waste landfill facilities. Special wastes include, but are not limited to, liquid waste, sludge, industrial process wastes, and waste from pollution control processes, residue from chemical cleanup, contaminated solids from chemical cleanups, containers and drums, and animal carcasses.

The County does not accept any type of special waste at its convenience centers. Any special waste generated within the County is the responsibility of the party producing the waste.

**R. HOUSEHOLD HAZARDOUS MATERIALS (HHM)**

Household Hazardous Materials (HHM) are products commonly used around the home, usually present in small amounts, that can be harmful to the health of individuals and the environment if improperly disposed. Examples of HHMs include paints, pesticides, cleaning supplies, and batteries. By law, these materials are considered elements of the municipal solid waste stream; yet

require special disposal to avoid potentially harmful effects to human health and environmental well-being.

**S. IMPORT & EXPORT OF WASTE**

The County allows for the import of MSW and C&D debris from out-of-county sources for disposal at private commercially permitted facilities. County convenience centers are provided for use by Anderson County residents.

However, special provisions granted by Anderson County's Environmental Services Division would allow for selective disposal at area convenience centers. Anderson County reserves the right to collect a host fee for any individual, commercial, or industrial entity disposing of solid waste at facilities owned and/or operated by the County.

The County allows for the export of MSW and C&D debris to permitted disposal facilities located outside of the County.

**T. SOLID WASTE DEPARTMENT FUNDING**

Anderson County currently obtains funding from the Solid Waste and Recycling Department from landfill tipping fees, solid waste household fees, commercial fees, waste tire disposal fees and recycling revenues. The County imposes a household fee on each residence in the County and a solid waste fee on every commercial business establishment located within the incorporated areas of the County, this does not include industries. These fees, which are assessed on the annual property tax notice, are levied as a uniform assessment by the County Auditor and are collected by the County Treasurer. Proceeds are deposited in a separate interest bearing account.

In accordance with the Act, the County shall annually determine the full cost for solid waste management services. Such figures will help to establish the annual

Anderson County

solid waste fee. The County shall publish a notice in a newspaper of general circulation by October 1<sup>st</sup> of each year setting forth the full cost to all users on an individual basis of its solid waste management services for the previous Fiscal Year.

In order to collect these fees in a timely manner, Anderson County has implemented a course of action for the collection of unpaid fees.



**V. FUTURE SOLID WASTE MANAGEMENT FACILITIES**

This section of the Anderson County Solid Waste Management Plan outlines the County's vision for the development of new and replacement solid waste management facilities in Anderson County. Prior to the permitting and/or development of a new or replacement facility, SCDHEC will make a determination of consistency regarding this Plan. Future Solid Waste Management Facilities should be conceived in an effort to improve the lives of Anderson County residents.

**A. WASTE STREAM PROJECTIONS**

Prior to October 1<sup>st</sup> of every year, Anderson County personnel prepare an annual report for submittal to SCDHEC containing the waste stream projections for solid waste management facilities.

**Municipal Solid Waste**

Approximately 152,187 tons of "defined" municipal solid waste was disposed of in the County from July 1, 2002 to June 30, 2003 according to the 2003 Solid Waste Management Annual Report. This tonnage does not reflect that amount of municipal solid waste generated within the County and transported to another disposal facility directly by any private collection company. Currently, the County does not regulate the amount of waste and disposal locations of waste collected by private companies. Many commercial and industrial establishments have individual contracts with these private waste collection companies. The tonnage of waste transported by these companies is not provided by the County, but obtained through SCDHEC. The County is considering the implementation of a monitoring program requiring private haulers to provide waste stream information to the County Solid Waste and Recycling Department.



A per capita waste generation rate of 4.4 pounds was calculated based upon the 2003 projected county population of 170,578 and the total municipal solid waste generated in the County. During the 1999 Legislative Session, SCDHEC proposed to establish a municipal solid waste generation goal of 3.5 pounds per person per day by June 30, 2005. The County's calculated value of 4.4 exceeds the goal set forth by SCDHEC. In order to reach this goal, Anderson County will continue its best efforts with source reduction and recycling. Table V-1 illustrates the municipal solid waste projections for the County during the next twenty (20) years based on a decrease in generation rate, to a level more consistent with the State's goal, and the increasing population of Anderson County.

**Table V-1- Municipal Solid Waste Projections**

Year	Population	Per Capita Generation Rate (goal)	Annual MSW (tons)
2005	172,120	4.2	131,930
2006	174,628	4.0	127,479
2007	176,234	3.8	122,218
2008	177,844	3.6	116,843
2009	179,449	3.5	114,623
2010	180,280	3.5	115,154
2011	182,661	3.5	116,674
2012	184,270	3.5	117,703
2013	185,876	3.5	118,728
2014	187,482	3.5	119,754
2015	188,440	3.5	120,366
2016	190,697	3.5	121,808
2017	192,303	3.5	122,833
2018	193,908	3.5	123,859
2019	195,514	3.5	124,885
2020	196,590	3.5	125,572
2021	198,730	3.5	126,939
2022	200,335	3.5	127,964
2023	201,941	3.5	128,990
2024	203,551	3.5	130,018

**Construction, Demolition, and Land-Clearing Debris (C&D)**

Approximately 52,247 tons of C&D debris was generated for disposal at the Starr C&D Landfill between July 1, 2002 and June 30, 2003 according to the 2003 Solid Waste Management Annual Report. Approximately 33,000 tons was disposed of in the Anderson County Starr Landfill. Other C&D debris in the County was transported to C&D Landfills. Since the County does not regulate the amount of waste transported by private haulers, it is difficult to obtain accurate quantification of the C&D debris generated within the County. The County is considering the implementation of a monitoring program requiring private haulers to provide detailed waste stream information to the County Solid Waste and Recycling Department.

A per capita C&D waste generation rate of 1.7 pounds was calculated based on the County's 2003 project population of 170,578 and the waste stream numbers published in the 2003 Solid Waste Management Annual Report. Anderson County aspires to reduce this per capita generation rate. In order to effectively reduce the C&D generation rate, Anderson County will continue efforts to promote composting within the County. Table V-2 illustrates the C&D debris projections for the County of the next twenty (20) years based on a decreasing generation rate and an increasing population.

**Table V-2- C&D Debris Projections**

Year	Population	Per Capita Generation Rate (goal)	Annual C&D (tons)
2005	172,120	1.5	47,118
2006	174,593	1.4	44,609
2007	176,198	1.3	41,803
2008	177,808	1.2	38,940
2009	179,413	1.1	36,017
2010	180,280	1.0	32,901
2011	182,624	1.0	33,329
2012	184,234	1.0	33,623
2013	185,839	1.0	33,916

Year	Population	Per Capita Generation Rate (goal)	Annual C&D (tons)
2014	187,444	1.0	34,209
2015	188,440	1.0	34,390
2016	190,659	1.0	34,795
2017	192,264	1.0	35,088
2018	193,870	1.0	35,381
2019	195,475	1.0	35,674
2020	196,590	1.0	35,878
2021	198,690	1.0	36,261
2022	200,295	1.0	36,554
2023	201,900	1.0	36,847
2024	203,510	1.0	37,141

#### B. FUTURE WASTE MANAGEMENT FACILITIES

All solid waste facilities and equipment are planned, designed, and operated as an integral function of the Anderson County Solid Waste Management Plan. All facilities and equipment must be selected to ensure that maximum efficiency for operation, proper location for use by county residents, transportation cost, and public safety. The County will strive to make purchases as economical as possible without compromising the integrity of a safe and sound solid waste management system for its residents. Any proposed solid waste management facility, either public or private, must be designed and constructed in accordance with the goals and objectives set forth in the South Carolina Solid Waste Management Plan and the Anderson County Solid Waste Management Plan.

Future solid waste management facilities include both new, replacement and expansion facilities. All facilities must not only meet regulatory requirements as set forth by SCDHEC Solid Waste Management Regulation Chapter 61, Section 107, but also be conceived in an effort to provide economical and effective disposal of solid waste for Anderson County residents. To accomplish these goals, Anderson County will only allow the siting of a new, replacement,

Anderson County

or expansion facility in accordance with the Plan. It is the preference of Anderson County that expansion facilities be the prime method of increasing solid waste capacities within the County. Replacement or expansion facilities located on or adjacent to property currently used for solid waste disposal would be favored rather than facilities located in an alternative area of the County. However, Anderson County seeks to provide safe and reliable solid waste management service to all residents in the County. Should a particular area of the County, not currently being served by existing facilities, be targeted for the placement of a new or replacement solid waste management facility, Anderson County will, in conjunction with the determination of consistency by SCDHEC, determine if the facility meets the goals and or disposal needs of the County. Private entities pursuing a permit from SCDHEC are encouraged to establish communication with Anderson County's Environmental Services Division prior to submitting an application to SCDHEC. By including Anderson County in the planning and development of a new or replacement facility, conflicts of interest can be alleviated or perhaps even avoided.

**C. COLLECTION, TEMPORARY STORAGE, & TRANSPORTATION OF SOLID WASTE**

The County plans to collect and transport its municipal solid waste, C&D debris, and recyclable materials utilizing procedures currently in place, as outlined in *Section IV- Existing Solid Waste Management* of this Plan. The County is continually evaluating the potential need for additional convenience centers and recycling centers in areas of the County with increasing growth rates. The County is in the process of studying the feasibility of expanding and/or renovating the Jockey Lot Convenience Center, Friendship Community Convenience Center and the Mountain Spring Community Convenience Center. In addition to the County is evaluating the expansion and/or renovation of other convenience centers throughout the County.

The County is evaluating the possibility of regulating private waste companies

to ensure the safe, clean and timely removal of municipal solid waste and to enable the Solid Waste and Recycling Department to maintain more accurate records of the County's waste stream.

Specifically, the County is evaluating the possibility of requiring all solid waste transport vehicles to meet specific criteria in regards to safety, protecting human health and the environment. All transported waste would be required to be covered and be in vehicles designed to minimize leakage of liquids.

All private waste companies operating in the County must submit an Annual Progress Report to the Solid Waste and Recycling Department by September 1<sup>st</sup> of each year. This report should include the amount of waste collected, the area in which it was collected, and other pertinent information as requested by the County.

The County is also considering the implementation of a solid waste facility host fee for all facilities located in the County which accept waste from out-of-county sources. To control and track the import of waste from out-of-county sources, the County is evaluating the possibility of requesting vehicle registration information or driver's licenses to verify County residency prior to disposal. Only those individuals providing valid documentation reflecting Anderson County (County Code 004) as the county of residency would be allowed to dispose of wastes at the convenience centers. It is anticipated that such an initiative would significantly decrease the amount of out-of-county wastes.

A goal of the Anderson County Environmental Services Division is to develop and implement a Convenience Center Plan whereby all county residents have equal and convenient access to waste disposal at reasonable cost to the County. The purpose of the plan is to streamline the County's efforts by operating each

convenience center in a more efficient manner. Under the plan, each convenience center will be evaluated for the type of materials regularly being disposed and a determination made by the County on the effectiveness of the current services. Upon evaluation of each convenience center, the County will develop a solid waste disposal system specifically tailored to the usage patterns identified in the evaluation. Regionalization of sites will enable the County to offer a specialized range of services most suited to the general disposal patterns of local residents. A full-service regional convenience center will provide all currently available disposal services, while local centers will provide those services consistent with the local usage patterns. The regionalization of the disposal areas within the county will account for travel distances, population, capacity of regional sites, and volume of waste anticipated. Regardless, the County will attempt to maintain the current level of service at all convenience centers so that all county residents have convenient access to waste disposal.

**D. SOLID WASTE TRANSFER STATION**

As stated in *Section IV – Existing Solid Waste Management*, Anderson County is host to one (1) solid waste transfer station within the County, Waste Management's Pendleton Transfer Station. With the development of the Anderson Regional Landfill seventy-five (75)-acre lateral expansion, it is anticipated that most of the municipal solid waste generated by residents of the County will be disposed of within this facility or transported elsewhere via the Pendleton Transfer Station. Exhibit H illustrates the two (2) aforementioned solid waste facilities. As demonstrated in this exhibit, the Pendleton Transfer Station is approximately twenty (20) miles from the municipal solid waste landfill, Anderson Regional Landfill. The privately operated Pendleton Transfer Station is also located near a moderately populated area, south of the Town of Pendleton and Clemson University. This facility, owned and operated by Waste Management, Inc. of South Carolina, utilizes other Waste Management facilities for the disposal of municipal solid wastes. Anderson

County acknowledges the fact that competition in industry leads to lower prices and improved service. Therefore, it is the opinion of the County that new publicly or privately owned transfer stations proposed within Anderson County be permissible, provided they comply with this Plan, meet requirements set forth by the Act, as amended, and comply with applicable ordinances enforced by the County.

**E. SOLID WASTE PROCESSING FACILITIES**

There are four (4) Solid Waste Processing Facilities currently mentioned in *Section IV – Existing Solid Waste Management*. Of these facilities, only the Anderson Regional Materials Recovery Facility, owned and operated by the County, accepts municipal solid waste. The remaining processing facilities do not collect municipal solid waste. Anderson County encourages the continued recycling efforts of these processing facilities.

Anderson County recognizes the need for Material Recovery Facilities to increase recycling rates within the County and does not prohibit the development of these facilities. A new or replacement facility must comply with applicable ordinances enforced by the County and is subject to host fees established by the County for the disposal of out-of county waste.

**F. MUNICIPAL SOLID WASTE (MSW) LANDFILLS**

According to SCDHEC's Demonstration-of-Need Regulation (R 61-107.17), the Anderson Regional Landfill's recent lateral expansion is designated as a regional disposal facility for municipal solid waste in the upstate of South Carolina. As illustrated in Exhibit I, the seventy-five (75)-mile planning radius, on which the demonstration-of-need was determined, prohibited the

**LEGEND**

Landfill ▲

Solid Waste Transfer Stations ■



**ANDERSON COUNTY  
MUNICIPAL SOLID WASTE FACILITIES**



**EXHIBIT H**

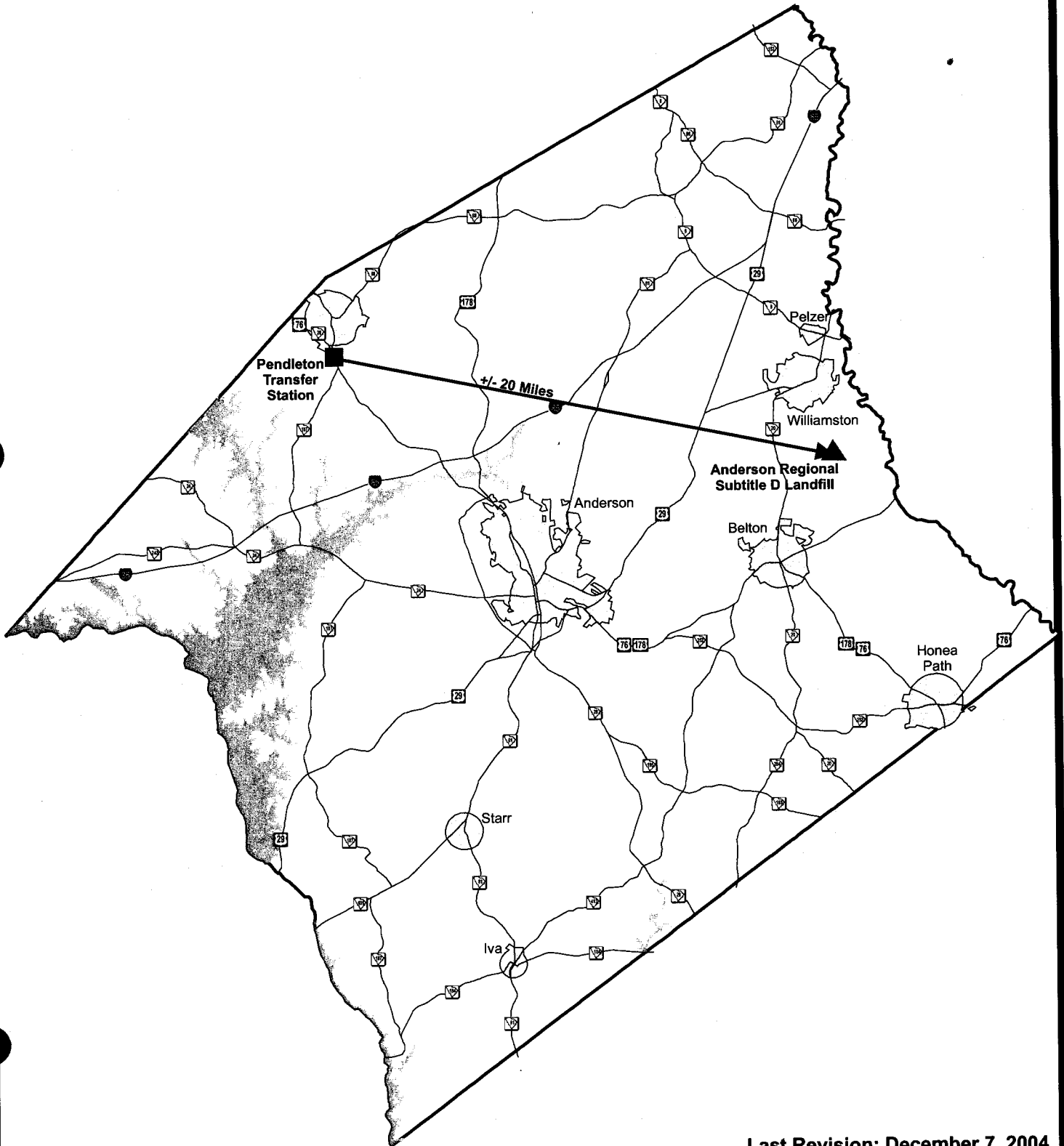

**Last Revision: December 7, 2004**



# South Carolina Municipal Solid Waste Landfills (MSWLF)



EXHIBIT I

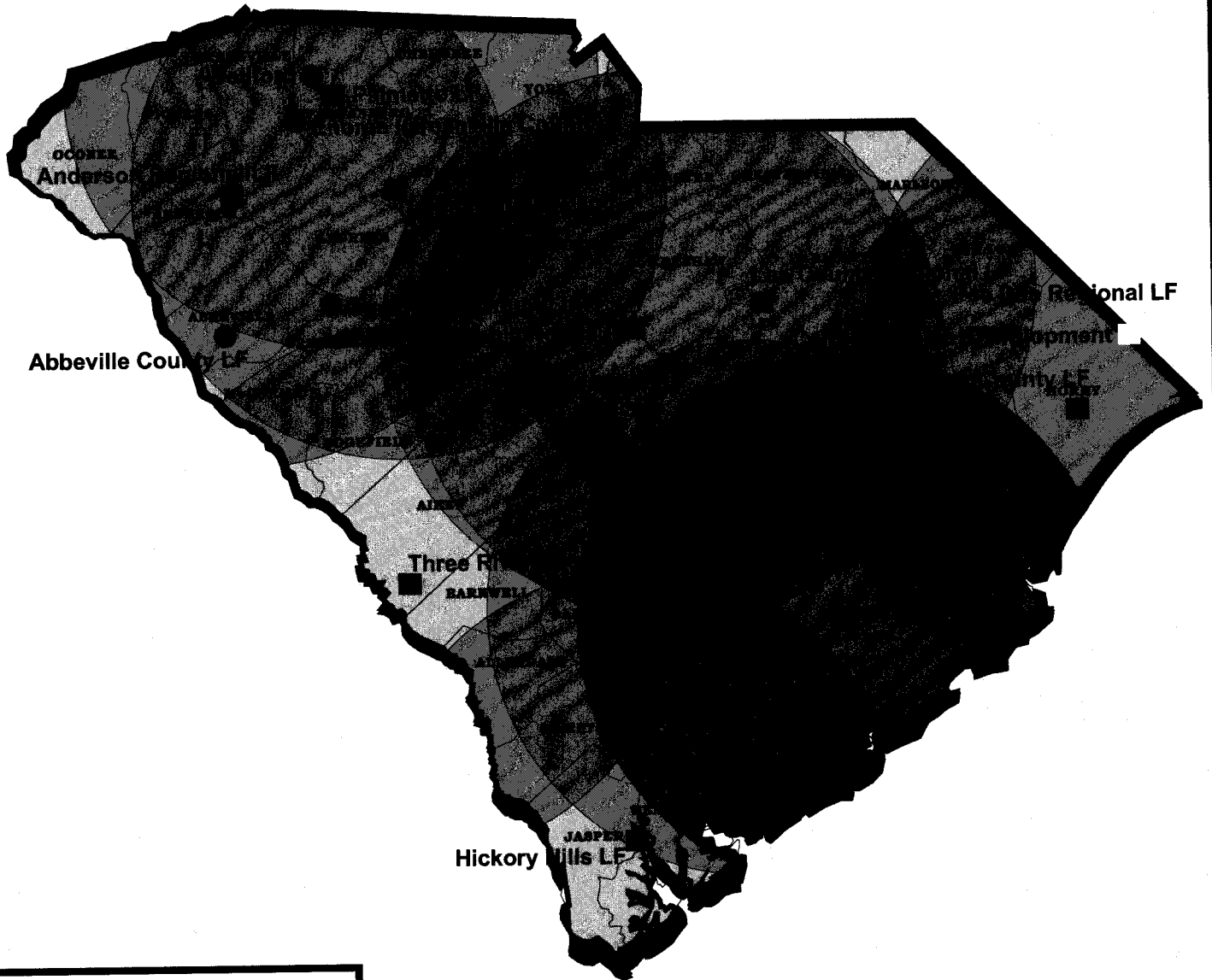

### LEGEND

Proposed MSWLF



In County MSWLF



In/Out of County MSWLF



75 Mile Radius  
(In-out of County Only)



Last Revision: December 7, 2004

development of any additional Subtitle D Landfills within the County, except for the replacement of the Anderson Regional Landfill when it reaches capacity. Anderson County has reserved capacity at the Anderson Regional Landfill for an expanse of twenty (20) years. Under the current disposal rates, the Anderson Regional Landfill will have available capacity for approximately forty (40) years. Therefore, there is no need for additional municipal solid waste disposal capacity within the County.

**G. SLUDGE MONOFILLS**

Sludge generated in the County is currently transported for disposal at the Anderson Regional Landfill. Anderson County does not prohibit the development of new and/or replacement sludge monofills complying with SCDHEC regulations.

**H. INCINERATOR ASH MONOFILLS**

There are no permanent solid waste incinerators located within the County. The lack of significant volume of incinerator ash indicates the lack of need for any incinerator ash monofills within the County. Anderson County prohibits the development of new or replacement incinerator ash monofills.

**I. CONSTRUCTION, DEMOLITION, & LAND-CLEARING DEBRIS (C&D)  
LANDFILLS**

According to the 2003 Solid Waste Management Annual Report published by SCDHEC, approximately 52,247 tons of C&D debris was disposed of in landfills within Anderson County. In addition, approximately 17,266 tons of C&D debris was recycled. Exhibit J illustrates a ten (10) mile radius around Anderson County's commercial C&D landfills. Anderson County has prepared the following statements as to the development of new and replacement Construction, Demolition, and Land-Clearing Debris Landfills within the County.

ANDERSON COUNTY  
CONSTRUCTION, DEMOLITION, & LAND CLEARING  
(C&D) LANDFILLS



EXHIBIT J

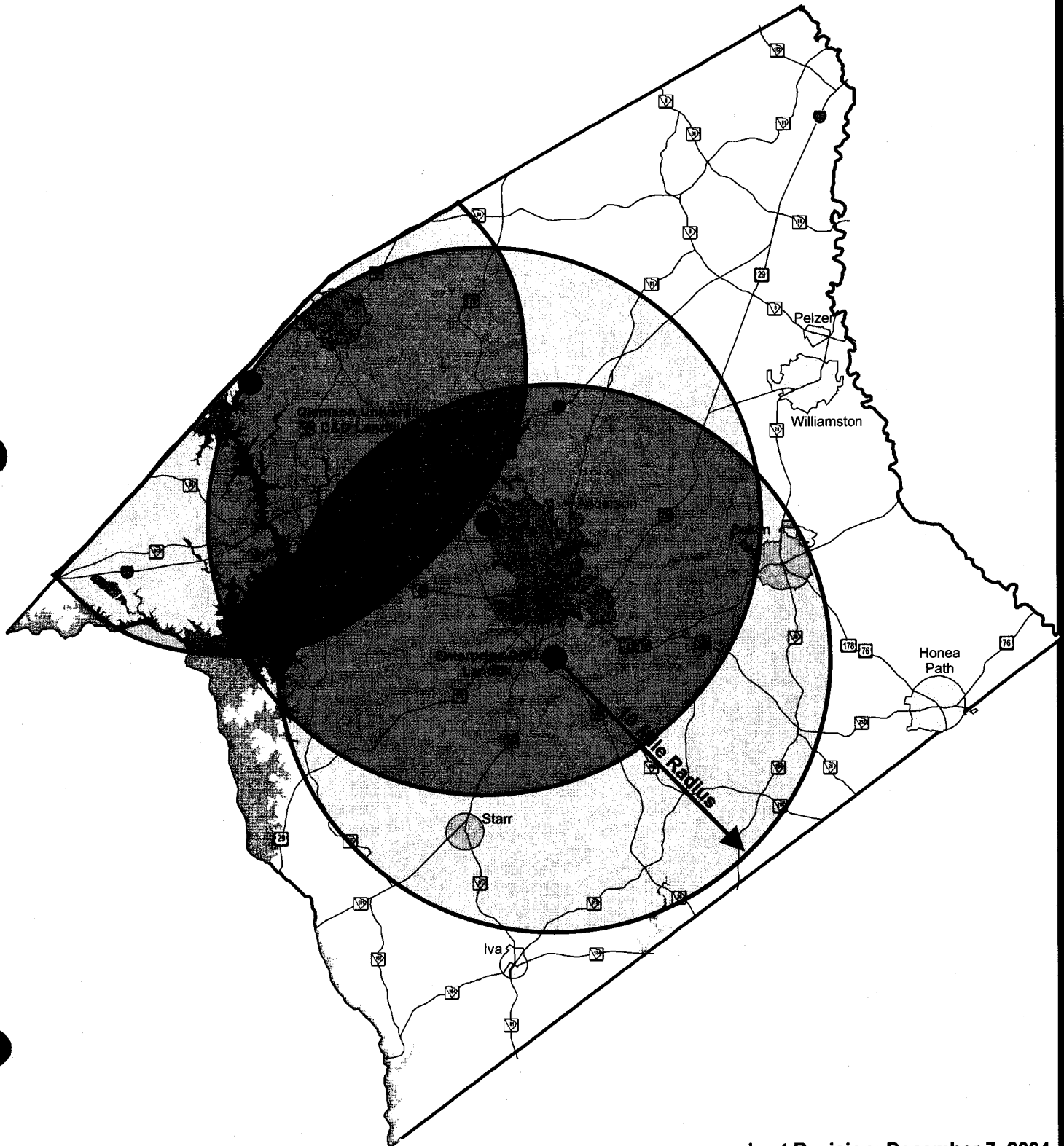

Last Revision: December 7, 2004

**Part I C&D Landfills**

Due to the nature of Part I, short-term C&D Landfills, Anderson County will permit the development of these facilities, provided they meet all the permitting and pertinent ordinances established by both the County and SCDHEC.

**Part II C&D Landfills**

Part II C&D Landfills are effective in retaining valuable municipal landfill space. However, the County would like to see a strong effort made into the reduction (chipping/grinding) and recycling (composting) of suitable materials. Currently three (3) Part II C&D Landfills are located within Anderson County. Two (2) of the three (3) privately owned facilities, Shaw Grading – Thompson Site and Miller Construction Company, utilize the facilities for disposal of land-clearing debris and yard trash generated from business conducted by each company, respectively.

Anderson County does not limit the development of new or replacement Part II C&D Landfills, but does suggest that any new or replacement facilities implement reduction and/or recycling programs into daily operational activities.

**Part III C&D Landfills**

Part III C&D Landfills are those facilities accepting construction, demolition, and land-clearing debris associated with permanent industrial establishment. There are currently no permitted Part III C&D Landfills located within Anderson County. Anderson County will permit such a facility, should an industry located within the County request the development, or a current industry elect to develop, a Part III C&D landfill. Any facility is subject to applicable ordinances enforced by the County, as well as requirements for regulatory permitting through SCDHEC.

**Part IV C&D Landfills**

Part IV C&D Landfills are permitted landfill facilities that aren't expressly classified under Parts I, II, or III of SCDHEC Regulations. There are currently three (3) operational Part IV C&D Landfills. Exhibit J illustrates these three (3) facilities and the ten (10) mile planning radius outlined in SCDHEC Demonstration-of-Need Regulation 61-107.17. However, the Clemson University Landfill doesn't accept waste from entities other than Clemson University. This landfill is required to be classified as a Part IV C&D due to the fact that C&D waste is transported across county lines for disposal.

The Anderson County Starr C&D Landfill recently permitted expansion is expected to reach capacity in more than the twenty (20) year planning term of this document, providing adequate disposal capacity for the residents of Anderson County. In addition, the recently opened Enterprise Materials Handling C&D Landfill increases the current disposal capacity within the County. No new or replacement Part IV C&D Landfills are permissible in Anderson County. Expansion facilities are permissible provided the landfill satisfies the constraints of the applicable ordinances enforced by the County, as well as requirements for regulatory permitting through SCDHEC.

Anderson County reserves the right to collect host fees from any entity disposing of out-of-county waste at facilities within the County.

**J. INDUSTRIAL SOLID WASTE (ISW) LANDFILLS**

The County has no plans to develop a publicly owned and operated solid waste landfill at the time. The County limits Industrial Solid Waste Landfills (Class 1, Class 2, & Class 3) from being developed within the County. The planning radius of a commercial ISW Landfill is seventy-five (75) miles, as illustrated in Exhibit K. According to SCDHEC's 2003 Solid Waste Annual Report, approximately 27,378 tons of ISW generated within Anderson County, was disposed in ISW Landfills. The two (2) commercial ISW Landfills located

# South Carolina Commercial Industrial Solid Waste Landfills



EXHIBIT K

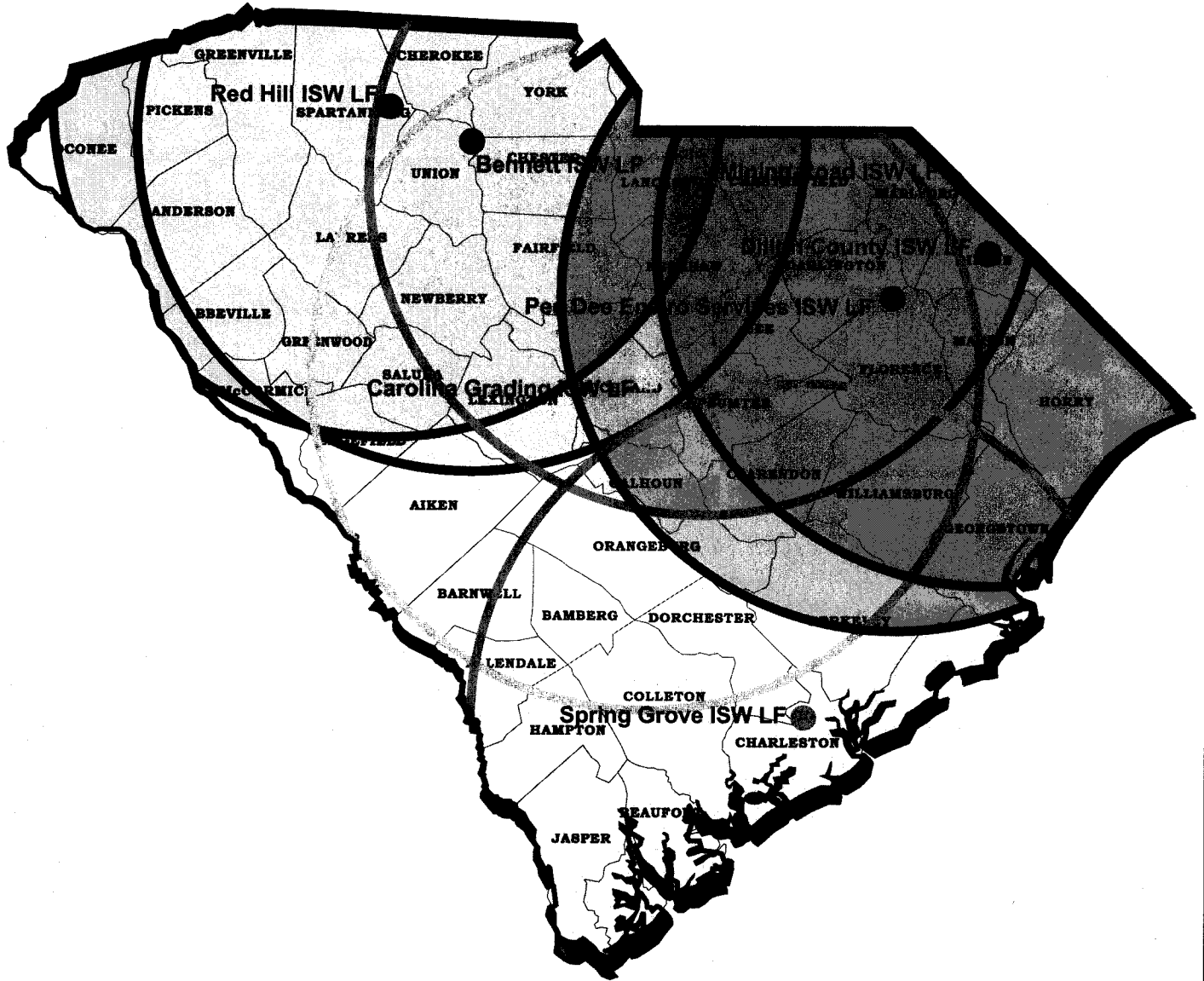

**LEGEND**

Class 1 ISW Landfills 

75 Mile Radius 

within seventy-five (75) miles of Anderson County are the Red Hill ISW Landfill and Bennett ISW Landfill.

**K. SOLID WASTE INCINERATORS**

The County has no plans to design, permit, or construct a publicly owned municipal solid waste incinerator within Anderson County. Anderson County currently has sufficient capacity available in existing MSW Landfills for disposal of municipal solid waste and therefore will not allow the development of municipal solid waste incinerators within the County. However, temporary air curtain incinerators may be permissible in severe debris generating events, such as significant tornadoes, earthquakes, destructive winter storms, and wide spread fires. Extreme conditions warranting emergency response actions may allow temporary facilities in accordance with disaster areas identified by the State of South Carolina Governor's Office. Anderson County prohibits the development of municipal solid waste incinerators at this time.

**L. COMPOSTING & WOOD CHIPPING/SHREDDING FACILITIES**

As stated in *Section IV – Existing Solid Waste Management*, three (3) composting and wood-chipping/shredding facilities are located in Anderson County; the City of Anderson, Town of Honea Path, and Town of Williamston. The County is considering the development of a County owned and operated composting facility to serve the residents. The County is committed to the concept of composting in an effort to reuse our natural resources and conserve landfill space. Anderson County encourages the development of properly permitted composting and wood-chipping/shredding facilities.

**M. USED OIL COLLECTION & PROCESSING FACILITIES**

As stated in *Section IV – Existing Solid Waste Management*, the County collects used oil at its convenience centers and other locations throughout the County. As new convenience centers are required due to an increasing

population, Anderson County will include additional used oil collection locations, in conjunction with new convenience centers. Through the County's participating in Santee Cooper's GOFER program, all used oil is transported and processed at an out-of-county facility. Anderson County does not limit the development of new oil processing facilities within the County but plans to continue participation in the GOFER program.

**N. WASTE TIRE HAULERS, COLLECTION FACILITIES, PROCESSING FACILITIES & DISPOSAL FACILITIES**

There is a currently one (1) registered waste tire hauler in Anderson County (Upstate Junk Processing, Inc.). Future Waste Tire Haulers are permissible.

Waste tires collected at the Anderson Regional Materials Recovery Facility are transported for recycling by Anderson Tire Recycling, a privately owned tire processing company. Anderson Tire is currently the only facility permitted for the processing and/or disposal of waste tires in Anderson County. The County encourages the processing and recycling of waste tires in order to reduce disposal requirements for these materials.

Anderson County prohibits the development of any new or replacement or expansion waste tire disposal facilities within Anderson County.

**O. RESEARCH, DEVELOPMENT, & DEMONSTRATION (RD&D) PERMITS**

The County is considering the development of Landfill Gas to Energy projects at the closed Starr and Pendleton MSW Landfills. These projects would utilize the methane generated at the landfills for energy to operate possible on-site greenhouse or nearby industries. Anderson Regional Landfill, LLC is exploring the possibility of developing an alliance with Clemson University and Anderson County for a landfill gas to energy project.



Anderson County supports the development of new technology to improve the efficiency and environmental friendliness of solid waste management. As new technology and grant money become available in the future, the County will further evaluate the possibility of pursuing an RD&D permit from SCDHEC. Entities privately pursuing a RD&D permit from SCDHEC are encouraged to communicate with the Anderson County Environmental Services Division to ensure that the facility meets the standards and expectations of the County.

**P. LAND APPLICATION OF SOLID WASTE PERMITS**

Anderson County does not plan on pursuing any permits for the land application of Solid Waste. The County would consider supporting the practice of land application of solid waste provided that the owner and /or operator meet all the requirements of SCDHEC and the process is sensitive to environmental issues.

**Q. RECYCLING PROGRAMS**

Anderson County intends to continue its effort to expand the current recycling program implemented throughout the County:

- Improving recycling collection facilities at its convenience centers through better signage and layouts, in addition to the increased training for attendants at the centers.
- Expanding the type of materials collected for recycling when market conditions indicate.
- Promote the practice of backyard composting to reduce the amount of food and yard waste being landfilled.
- Support the municipal curbside recycling programs with ongoing training, educational materials, and publicity.
- Encourage private haulers to offer recycling in conjunction with general trash pick-up services.
- Expand existing recycling education efforts by increasing outreach to the business community. Anderson County will evaluate the possibility

of allowing commercial businesses to dispose of recyclables at local convenience centers.

- Continue the “buy recycled” efforts at government offices and encourage local entities to do the same.
- Encourage the location of additional recycling related services and facilities.

**R. SPECIAL WASTES**

Anderson County owned facilities do not currently accept, nor will accept in the future, any type of special wastes at its solid waste management facilities. Handling methods required by these materials increase the cost of disposal and are considered by Anderson County the responsibility of the owner to ensure these materials are properly disposed. Anderson Regional Landfill, LLC will accept special wastes at the Anderson Regional Landfill in accordance with the Special Waste Plan enforced at the facility.

**S. HOUSEHOLD HAZARDOUS MATERIALS (HHM)**

The County supports the separation of Household Hazardous Materials (HHM) from the municipal solid waste stream; however, the County does not currently have a Household Hazardous Waste Program in place.

**T. IMPORT & EXPORT OF WASTES**

Anderson County, as host to the Anderson Regional Landfill, will continue to accept waste imported from other South Carolina Counties, provided adequate capacity is maintained for the disposal of in-county waste. The County reserves the right to collect host fees on all wastes imported into facilities within the political borders of Anderson County. The County will continue to allow the export of waste to permitted facilities by registered private waste companies.

**VI. GOALS, POLICIES, STRATEGIES, & BARRIERS**

Anderson County strives to provide a safe, beautiful, and environmentally friendly atmosphere for its citizens. Anderson County views solid waste management as a necessary public service to promote development similarly to potable water, reliable wastewater service, and electrical power. By setting goals, creating policies, developing strategies and identifying barriers, Anderson County will successfully provide the level of service its citizens deserve. To increase the awareness of solid waste issues in the community, the County has identified characteristics of a successful program. An effective solid waste management system addresses reduction, recycling, educational programs, available grant information, and dedicated, knowledgeable staff willing to communicate the County's expectations for solid waste management.

**A. REDUCTION GOALS**

In June 2000, the solid waste management goals outlined in the Act were revised as follows: "It is the goal of this State to reduce, on a statewide per capita basis, the amount of municipal solid waste being generated to 3.5 pounds per day not later than June 30, 2005". In addition, the following definition was amended stating "municipal solid waste includes, but is not limited to, wastes that are durable goods, not-durable goods, containers and packaging, food scraps, yard trimmings, and miscellaneous inorganic wastes from residential, commercial, institutional, and industrial sources including, but not limited to, appliances, automobile tires, old newspapers, clothing, disposable tableware, office and classroom paper, wood pallets, and cafeteria wastes. Municipal solid waste does not include solid wastes from other sources including, but not limited to, construction and demolition debris, auto bodies, municipal sludges, combustion ash, and industrial process waste that also might be disposed of in municipal waste landfills or incinerators".

In order for the County to meet the 3.5 pound per day per capita waste generation reduction goal, the amount of waste generated within the County must be reduced by its citizens, businesses, and organizations. Speaking engagements, tours of solid waste management facilities, newspaper articles, displays, and conferences are some of the methods of source reduction that Anderson County will consider. Continued education efforts in this area will increase the rate of reduction of items disposed in landfills. The public must become better informed of the benefits of source reduction and the various ways in which residents can help in this endeavor. By separating out a greater percentage of recyclable aluminum, glass, paper, cardboard, and plastic, the County's waste stream can be further reduced. In addition, the County's waste stream could be greatly reduced through the development of an extensive composting program. County residents must become aware of alternative methods of disposal such as reusing and repairing old items such as lawnmowers, tools, etc., as well as donating items such as clothing, mattresses, furniture, etc. to local charitable organizations. The County's source reduction education will also focus on utilizing and buying recycled products.

**B. RECYCLING GOALS**

In June 2000, the solid waste management goals outlined in the Act were revised as follows: "It is the goal of this State to recycle, on a statewide basis, at least thirty-five percent (35%), calculated by weight, of the municipal solid waste stream generated in this State no later than June 30, 2005".

The County currently has in place a voluntary countywide residential recycling program utilizing a system of convenience and recycling centers and four (4) municipal curbside collection programs. To meet and hopefully exceed the thirty-five percent (35%) recycling goal established in this Act, more residents would have to choose to separate recyclables from their trash. Toward this end, private trash haulers have a key role to play since many persons already paying

for trash collection may not be willing to drive separately to the convenience and recycling centers to dispose of recyclable materials.

In order to achieve the thirty-five percent (35%) recycling goal established in the Act, more County businesses must also elect to recycle. The County intends to work with the business community to help them understand how recycling can save them money and to help them identify their recycling possibilities. The County is in the process of considering whether to provide access to convenience centers and recycling centers for the business community to dispose of recyclables.

**C. POLICIES**

Anderson County abides by the rules and regulations set forth by SCDHEC and the State of South Carolina in terms of solid waste management. In addition, Anderson County has issued a Land Use Ordinance for the County. All proposed solid waste facilities located within the County must abide by this Ordinance as well as all SCDHEC and State regulations protecting the health and safety of Anderson County citizens.

**D. STRATEGIES**

Anderson County incorporates numerous strategies to help conserve natural resources, save energy, and reduce the need to build landfills and incinerators. These strategies include educational programs to promote recycling, litter prevention, and waste reduction, applying for government grants promoting reduction and recycling, and providing access to solid waste and recycling personnel.

**1. Educational Programs**

The County's Solid Waste and Recycling Department, in conjunction with Keep America Beautiful of Anderson County, has established

educational programs addressing recycling, litter prevention, and waste reduction.

**Recycling Education Center**

The County's recycling education initiatives are an indispensable part of the County's recycling program. These initiatives include neighborhood, civic, school and business presentations, public awareness campaigns, workshops, theme days, displays at community events, and facility tours. Anchoring the County's recycling education program is the ongoing development of a Recycling Education Center. This "center" includes several facilities and displays, including a staffed recycling-only drop off site open seven days a week, an information center with exhibits suitable for indoor classroom use and meetings, an outdoor covered pavilion for larger group meetings and presentations, a turf demonstration developed in cooperation with Clemson University, and a composting display featuring a variety of backyard compost bins and techniques. Additional outdoor exhibits are in development.

Its location near the Anderson Sports and Entertainment Complex makes the Recycling Education Center an ideal location for day-long community events such as the annual Grinding of the Green, composting demonstrations and bin sales, and summer education for youth.

**Keep America Beautiful (KAB) of Anderson County**

The Keep America Beautiful (KAB) of Anderson County, officially recognized and established in the County in July 2000 by ordinance 2000-018, is a non-profit organization under the authority of the County with the purpose of education and empowering governments, businesses, and residents in the County to improve the environment through a grassroots effort in beautification, litter prevention, and waste reduction.

Anderson County

The KAB consists of more than 100 volunteers working alongside several County offices to change residents' habits and attitudes toward waste disposal. The KAB is involved in the community through the following programs and activities:

- *Business Protecting the Environment:* This program involves asking area businesses to evaluate their cleanup and waste disposal practices on an annual basis.
- *Deeds of Pride:* A countywide cleanup and beautification effort each April and October.
- *Freedom Weekend Aloft Anti-litter Campaign:* Volunteers distribute litterbags and anti-litter messages to Freedom Weekend Aloft participants. Hot Air Balloon Aloft reports illegal dumpsites.
- *Tarp Campaign:* Encourages County residents to cover their loads to lessen roadside litter.

The KAB promotes the anti-litter message in County schools using the KIDS program. The KIDS program includes anti-litter art contests, America Recycles Day, recycled scarecrow construction at the County fairgrounds, and the Tree Legacy program associated with Arbor Day. The KAB is also pursuing the Tree City USA designation for all municipalities in the County. The KAB is establishing an Adopt-A-Spot program, participates in the State's Adopt-A-Highway program, as well as sponsoring a yard beautification program.

The South Carolina Office of Solid Waste Reduction and Recycling was created by the Act and is part of the Division of Solid Waste Planning and Recycling. The Office of Solid Waste Reduction and Recycling, in accordance with the Act, provides educational, technical, and grant assistance to local governments, schools, colleges, universities, and general public regarding solid waste management issues. The County

will work with the Office of Reduction and Recycling to obtain assistance with their public education campaign and grant preparation.

**2. Grants**

SCDHEC has awarded the County grants for the preparing of recycling flyers, waste oil collection equipment, and educational materials. The County will continue pursuing solid waste assistance grants from SCDHEC in an effort to improve the recycling programs throughout the County.

**3. Technical Assistance**

Contacts for information concerning municipal solid waste management, recycling, and source reduction are as follows:

Anderson County Environmental Services Division

Mr. Vic Carpenter, Environmental Services Director  
Mr. David Scott, Environmental Engineering Manager  
Telephone: (864) 260-1001  
Facsimile: (864) 260-1002  
E-mail: [vcarpenter@andersoncountysc.org](mailto:vcarpenter@andersoncountysc.org)  
[dscott@andersoncountysc.org](mailto:dscott@andersoncountysc.org)

Anderson County Solid Waste & Recycling Department

Mr. Greg Smith, Solid Waste Manager  
Telephone: (864) 260-1001  
Facsimile: (864) 260-1002

Keep America Beautiful (KAB) of Anderson County

Ms. Michelle Strange, Coordinator  
Telephone: (864) 260-1004  
Facsimile: (864) 260-1002  
E-mail: [mstrange@andersoncountysc.org](mailto:mstrange@andersoncountysc.org)

Department of Health and Environmental Control

Office of Solid Waste Reduction and Recycling  
1-800-SOUSEIT (1-800-768-7348)



**E. BARRIERS**

The County realizes that there are many barriers restricting recycling, and are attempting to alleviate these barriers and continue to promote recycling within the County. The following barriers are faced by both the public and private sectors in Anderson County, making increasing the recycling rate within the County difficult:

- **Low Tipping Fees** – South Carolina's average tipping fee, \$36 per ton, is one of the lowest in the nation. These low disposal fees for municipal solid waste make separating recyclables a time consuming service that is not cost effective. Raising tipping fees may convince some individuals to consider separating recyclables. However, Anderson County must find a balance between these fees and the ability of the residents to pay. As increases in disposal fees will directly impact these citizens.
- **Lack of Funding** – Lack of funding from local, state, and federal sources may lead to fewer improvements to existing infrastructure as well as the possibility of cutting recycling services. To combat this, the County must apply for grants, as available, and consider these expenditures when deciding the budget.
- **Lack of Markets** – The lack of markets for certain recyclables means low prices for these materials resulting in these types of recyclables being dropped from many recycling services. The County will continue to observe and investigate future markets for recyclables and implement the collection of these materials when the market indicates.
- **Lack of Awareness** – Despite all that has been done to promote recycling, a large percentage of the population does not see recycling as an issue. Anderson County provides its residents with numerous educational opportunities and programs to promote recycling in the County and will continue to promote recycling to its residents.
- **Lack of Regulatory Requirements** – All recycling programs operating in the state are voluntary, including those in Anderson County. Through educating its residents and providing recycling opportunities, Anderson County promotes the participation in recycling programs.

- **MSW Generated Business** - Recycling efforts have focused primarily on residential programs, despite the fact that businesses are estimated to generate more than fifty percent (50%) of the State's municipal solid waste. Businesses are provided with cheap disposal options, which provide little incentive to reduce their wastes. Businesses are included as a part of the County's recycling education program, to allow them to evaluate their waste disposal practices on an annual basis. Additionally, Anderson County is considering providing access to businesses at the convenience center for recycling.
- **Lack of Accountability** – Until the recent promotion of recycling, local governments have held the responsibility for the end-of-life costs of managing materials. No incentive had been given for producers, sellers, and consumers to reduce the waste associated with products. Through recycling education, Anderson County has promoted recycling to these groups.

These barriers contribute to low recycling rates and high disposal rates. Anderson County is dedicated to adhering and exceeding the standards established in the Act. To accomplish these goals, Anderson County will have to address these barriers and attempt to overcome each by using education, knowledge, and innovation.

**VII. PLAN REVISION & CONSISTENCY WITH WASTE MANAGEMENT PLANS**

Anderson County, in accordance with SCDHEC requirements, submits the proper documentation regarding solid waste disposal in its Annual Progress Reports, and has prepared the Anderson County Solid Waste Management Plan. Anderson County, in its efforts to stay current with available information and continually improve its services, reserves the right to review and revise the Anderson County Solid Waste Management Plan.

**A. ANNUAL PROGRESS REPORTS**

Section 44-96-60 of the Code requires SCDHEC to submit to the Governor and General Assembly, a comprehensive report on solid waste management in South Carolina by the end of each calendar year. Therefore, SCDHEC requires all counties, including Anderson County, to submit an Annual Progress Report to the Department by October 1<sup>st</sup> of each year. The Annual Progress Report must contain at a minimum:

1. Any revisions to the solid waste management plan previously submitted by the County;
2. The amount of waste disposed of at municipal solid waste disposal facilities during the previous year by type of waste;
3. The percentage reduction each year in solid waste disposal at municipal solid waste facilities;
4. The amount, type, and percentage of materials that were recycled, if any, during the previous year;
5. The percentage of the population participating in various types of source separation, recovery, or recycling activities during the previous year; and
6. A description of the source separation, recovery, or recycling activities or all of the above activities attempted, if any, their success rates, the reason for their success or failure, and a description of such activities which are ongoing.

**B. REVISIONS TO THE ANDERSON COUNTY SOLID WASTE MANAGEMENT PLAN**

This Plan will be reviewed annually by the Anderson County Environmental Services Division to ensure consistency with the South Carolina Solid Waste Management Plan. Upon recommendation of the Environmental Services Division, proposed revisions to the Plan will be submitted to Anderson County Council for consideration, public comment and subsequent approval by Resolution.

Each page of the Anderson County Solid Waste Management Plan should clearly identify the name, page number, and date of last revision. Once a revision to the Plan has been approved by Anderson County Council, the modified portion of the Plan or the entire document as necessary, will be submitted to SCDHEC by the Administrator or Environmental Service Division Director. Accompanying the revised report will be a cover letter containing the following information:

- date of which the revisions are to take effect,
- documentation on the local approval process.

0905  
VII-2

In the event only amended sections are submitted, also include:

- instructions on how the revisions are to be inserted into the Plan currently on file with SCDHEC (which pages to replace).

Revisions not submitted by the Anderson County Administrator or Director of the Environmental Services Division should be revoked.

**C. CONSISTENCY DETERMINATIONS & DEMONSTRATION-OF-NEED REQUIREMENTS**

In accordance with South Carolina Regulation 61-107.17, "Solid Waste Management: Demonstration-of-Need", a permit applicant proposing to

construct a new, replacement or expand an existing municipal solid waste landfill, a C&D landfill, and an industrial solid waste landfill, or a municipal solid waste incinerator in the County must provide SCDHEC with the following information:

- A. The longitude and latitude coordinates for the proposed new facility of proposed expansion; and,
- B. The proposed disposal rate for the proposed new facility or for the proposed expansion of the existing facility.

Detailed plans and specifications are not required for SCDHEC to make a factual determination of need. SCDHEC will make a determination of need based on the following:

“Where there are at least two (2) commercial disposal facilities under separate ownership within the planning area that meet the disposal needs for the area, e.g., that accept special waste and, if applicable, are capable of handling additional tonnage, no new disposal capacity will be allowed”.

The following planning areas are used by SCDHEC for determining need:

Municipal Solid Waste Landfills	75-mile radius
Industrial Solid Waste Landfills	75-mile radius
Municipal Solid Waste Incinerators	75-mile radius
Industrial Solid Waste Incinerators	75-mile radius
Construction, Demolition, and Land-Clearing Debris (C&D) Landfills (Part IV)	10-mile radius

Exhibits I, J, and K illustrate the planning areas for existing facilities which have an impact on proposed facilities or facility expansions in Anderson County.

In addition to satisfying the determination of need requirements, a proposed solid waste facility must also obtain a Consistency Determination stating that

the proposed facility is consistent with the local solid waste management plan. Prior to SCDHEC issuing a Notice to Proceed with the planning of a solid waste management facility, SCDHEC will prepare a Preliminary Determination of Consistency. The host county will be informed of the preliminary determination in writing. The county is to submit relevant written comments back to SCDHEC regarding the county's position on the preliminary determination. If a response is not submitted within fifteen (15) days of receipt of SCDHEC's correspondence, SCDHEC will proceed with the preliminary decision. If a written response is submitted by the county, SCDHEC and the county will attempt to resolve the decision. If an agreement is not made within thirty (30) days of receipt of the initial written notice from SCDHEC, SCDHEC will proceed with the initial determination. If an agreement is reached, different from the initial determination, SCDHEC will notify the applicant in writing.

The three (3) preliminary determinations of consistency issued by SCDHEC are "consistent", "inconsistent" and "not inconsistent". If a preliminary determination of "inconsistent" is issued by SCDHEC, the facility, as submitted to SCDHEC, is not permitted. A preliminary determination of "not inconsistent" enables the applicant to proceed with the permitting process required by SCDHEC. However, the facility is still subject to Final Determination of Consistency. A "consistent" preliminary determination will be followed by a "Notice to Proceed" presented to the applicant. A facility issued a preliminary determination of "consistent" is still subject to Final Determination of Consistency.

For facilities deemed by SCDHEC "consistent" or "not inconsistent" during the preliminary determination, the final consistency determination shall be made by SCDHEC on the day the final permit is issued. The final determination shall be based on the county's plan of record on that date. If the final determination is

Anderson County

“consistent” and **all** technical concerns have been resolved, a permit will be issued to the applicant. If deemed “not consistent” the permit will be denied on such basis.

Any applicant seeking a permit to construct a solid waste management facility within the County must obtain a favorable determination of consistency in regards with the Anderson County Solid Waste Management Plan. It is the permit applicant’s responsibility to ensure consistency with the Plan. To be consistent with the Plan, a facility must be in the best interest of the County, based on a factual determination of specific criteria included in the Plan, and must conform with the same principals outlined in Section 44-96-20(B) of the Act, as amended, and meet the criteria specified in the local Plan.

**Chapter 58 SOLID WASTE\***

**Chapter 58 SOLID WASTE\***

**\*Cross references: Waste disposal systems in mobile home parks, § 50-96.**

**State law references: Garbage collection and disposal in counties, S.C. Code 1976, § 44-55-1010 et seq.**

**Article I. In General**

Sec. 58-1. Material recovery facilities; procedures for use; fees, rates.

Secs. 58-2-58-35. Reserved.

**Article II. Department of Solid Waste and Recycling**

Sec. 58-36. Designated; manager.

Secs. 58-37-58-60. Reserved.

**Article III. Landfill**

**Division 1. Generally**

Sec. 58-61. Definitions.

Sec. 58-62. Violations; penalties.

Secs. 58-63-58-80. Reserved.

**Division 2. Permit**

Sec. 58-81. Required.

Sec. 58-82. Approval; hearing.

Sec. 58-83. Conditions of issuance.



**ARTICLE I. IN GENERAL**

Page 1 of 1

**ARTICLE I. IN GENERAL****Sec. 58-1. Material recovery facilities; procedures for use; fees, rates.**

The county administrator and the county recycling coordinator are hereby directed to establish and organize the county's material recovery facilities in such a manner, to establish such procedures for the use of the county's material recovery facilities, and to set such fee and rate schedules for the use of the county's material recovery facilities so that such material recovery facilities will be self-supporting, in the broad, general sense; and equitably and evenly supported by all users and classes of users of the material recovery facilities. The administrator, and recycling coordinator are further directed to keep the council advised as to the progress in accomplishing these requirements and to bring before the council, for approval and implementation, the rate and fee schedules required by this section.

(Ord. No. 365, § 1, 1-5-93)

**Secs. 58-2-58-35. Reserved.**

**ARTICLE III. LANDFILLS**

Page 1 of 2

**ARTICLE III. LANDFILLS****DIVISION 1. GENERALLY****Sec. 58-61. Definitions.**

The following words, terms and phrases, when used in this article, shall have the meanings ascribed to them in this section, except where the context clearly indicates a different meaning:

*Landfill* means a method of disposing of solid waste on land without creating pollution, nuisances, or hazards to public health and safety, and, for purposes of this article, includes all equipment, locations, facilities and personnel necessary or incidental to the operation of the county's landfill(s), including but not limited to landfills, transfer stations, convenience stations, dumpsters, or portable landfills, or material recovery facilities.

*Solid waste* means garbage, refuse, litter, rubbish or any material resulting from industrial, commercial, agricultural or residential activities not disposable by means of a sewerage system operated in accordance with state regulations.

(Ord. No. 200, § III, 6-17-86)

**Cross references:** Definitions generally, § 1-2.

**Sec. 58-62. Violations; penalties.**

(a) Whenever the county solid waste department finds that any person is in violation of any permit, regulation, standard or requirement under this article the department may issue an order requiring such person to comply with such permit, regulation, standard or requirement or the department may request that the county attorney bring civil action for injunctive relief in the appropriate court; or, the department may request that the county attorney bring civil enforcement action under subsection (b) of this section. Violation of any court order issued pursuant to this section shall be deemed contempt of the issuing court and punishable therefor as provided by law. The department may also invoke civil penalties as provided in this section for violation of the provisions of this chapter, including any order, permit, regulation or standard. Any person against whom a civil penalty is invoked by the department may appeal the decision of the department to the court of common pleas for the county. None of the provisions of this subsection shall in any way limit any other enforcement or punishment.

(b) Any person who violates any provision of this article shall be liable for a civil penalty not to exceed \$5,000.00 per day of violation.

(c) Any person who willfully violates any provision of this article shall be deemed guilty of a misdemeanor and upon conviction shall be punished in accordance with section 1-7.

(Ord. No. 200, § V, 6-17-86)

**Secs. 58-63--58-80. Reserved.**

**DIVISION 2. PERMIT**

**ARTICLE III. LANDFILLS**

Page 2 of 2

**Sec. 58-81. Required.**

No solid waste shall be disposed of in landfills situated in the county by any nonresident person or entity, county, municipality, special purpose district, or political subdivision created, organized or existing under the laws of this state or any other state without a permit first being issued by the solid waste department and being duly approved by the county council.

(Ord. No. 200, § I, 6-17-86)

**Sec. 58-82. Approval; hearing.**

Approval of a permit under this division by the county council shall be had by the nonresident entity or person filing a petition with the clerk of the county council and a public hearing being held prior to the issuance of the approval by the council.

(Ord. No. 200, § II, 6-17-86)

**Sec. 58-83. Conditions of issuance.**

If a permit is issued under this division the permittee shall abide by and comply with all regulations issued by the county solid waste department.

(Ord. No. 200, § IV, 6-17-86)

**ARTICLE II. DEPARTMENT OF SOLID WASTE AND RECYCLING**

Page 1 of 1

**ARTICLE II. DEPARTMENT OF SOLID WASTE AND RECYCLING****Sec. 58-36. Designated; manager.**

The solid waste authority is hereby designated as a department of county government and shall be known as the department of solid waste and recycling with the manager reporting directly to the county environmental services director.

(Ord. No. 298, § 2, 1-23-90)

Secs. 58-37-58-60. Reserved.

**APPENDIX A  
ANDERSON COUNTY  
SOLID WASTE ORDINANCE**

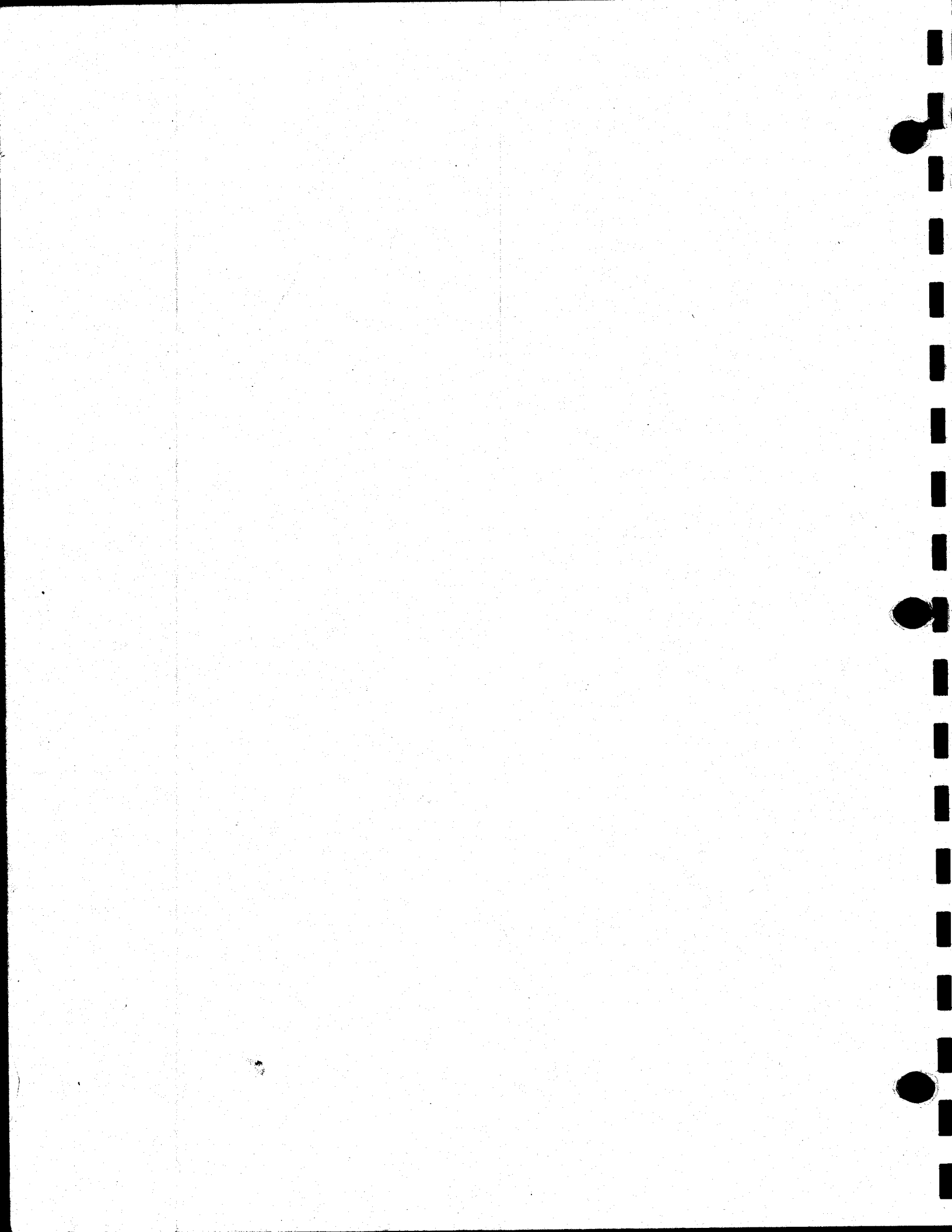

<b>Greenpointe Landfill Adjoining Properties</b>		
<b>TMS#</b>	<b>Owner</b>	<b>Address</b>
138-00-05-004	Debra Lynn Sheridan Life Estate	818 Hamlin Road, Easley, South Carolina 29642
138-00-05-003	Timothy Allen Moore	828 Hamlin Road, Easley, South Carolina 29642
138-00-05-001	Timothy Allen Moore	828 Hamlin Road, Easley, South Carolina 29642
138-00-05-002	Timothy Allen Moore	828 Hamlin Road, Easley, South Carolina 29642
138-00-04-016	Thomas T. Gaede & Lauren M. McNally	778 Hendricks Road, Easley, South Carolina 29642
138-00-04-015	Douglas J. Martin & Anne H. Martin	118 Alpen Road, Easley, South Carolina 29642
138-00-04-010	Brian Speedy & Michelle Speedy	858 Hamlin Road, Easley, South Carolina 29642
138-00-04-014	Brett F. Stansell & Angela L. Stansell	102 Indigo Lane, Easley, South Carolina 29642
164-00-02-037	Tony M. Todd & Jean Todd	606 Hendricks Road, Easley, South Carolina 29642
164-00-02-038	Jamie S. Nix	544 Hendricks Road, Easley, South Carolina 29642
164-00-02-001	Curtis Jackson, Jr.	104 Oldfield Court, Lexington, South Carolina 29072
164-00-02-061	Michelle Jackson	309 Delaine Woods Drive, Irmo, South Carolina 29063
164-00-02-060	Lenora Jackson Simpson	125 A Karen Court, Bridgeport, Connecticut 06606
164-00-02-059	John Jackson	541 Mildred Street, Anderson, South Carolina 29621

### Greenpointe Landfill Adjoining Properties

TMS#	Owner	Address
164-00-02-058	Jackson Aquillious	100 Acquillions Lane, Easley, South Carolina 29642
164-00-02-057	Curtis Jackson, Jr.	104 Old Field Court, Lexington, South Carolina 29072
164-05-01-167	Avendell Homeowners Association, Inc.	Post Office Box 1827, Greenville, South Carolina 29602
164-00-02-034	Walter R. Meece & Katie S. Meece	406 Wilderness Trail, Liberty, South Carolina 29657
164-00-02-035	Donne H. Crawford	408 Wilderness Trail, Liberty, South Carolina 29657
165-00-04-054	James W. Cruse, Jr.	430B Wilderness Trail, Liberty, South Carolina 29657
165-00-04-053	James W. Cruse, Jr.	430B Wilderness Trail, Liberty, South Carolina 29657
165-00-04-052	Jerry R. Turner & Carter D. Turner	1730 Geer Highway, Travelers Rest, South Carolina 29690
165-00-04-051	Becky Jeanette Halbert	504 Wilderness Trail, Liberty, South Carolina 29657
165-00-04-011	Morris R. Smith & Morine N. Smith	141 Lydia Drive, Liberty, South Carolina 29657
165-00-04-010	Stanley R. Gallimore & Delores S. Gallimore	142 Lydia Drive, Liberty, South Carolina 29657
165-00-04-001	Sherry Faye Carter	410 Hamlin Road, Liberty, South Carolina 29657
138-00-03-048	Lonnie Allen Suddeth	415 Hamlin Road, Liberty, South Carolina 29657
138-00-03-008	Garth B. Davis & Sherry D. Alexander	503 Hamlin Road, Easley, South Carolina 29642
138-00-03-007	Smith Carvery Ann W. & A Michael Smith	817 Hamlin Road, Easley, South Carolina 29642





Application for Permit to Construct a Solid Waste Management System
Bureau of Land and Waste Management

Submit to: Division of Mining and Solid Waste Permitting, Bureau of Land and Waste Management
SC Department of Health and Environmental Control, 2600 Bull Street, Columbia, SC 29201-1708
(Please Print or Type)

I. Name of project: Greenpointe Class Two C&D Landfill Expansion

II. Physical location (Directions to project - use street names, county road numbers, etc.):
500 Hamlin Road, Easley, South Carolina 29642 County: Anderson

Latitude and longitude (nearest 15 seconds) or UTM coordinates:
34°43'36.12"N 82°36'43.56"W

III. In accordance with Title 44, Chapter 96 of the Code of Laws of South Carolina, 1976, as amended, I hereby make application, on behalf of the party(ies) whose name(s) appears below, for a permit to construct and operate the following type of solid waste management project (describe):
Class II Construction and Debris Greenpointe Landfill Expansion, located along Hamlin Road, in Anderson County, SC

IV. Facility name, mailing address: Greenpointe Landfill
500 Hamlin Road, Easley, South Carolina 29642 Telephone number: (864) 223-0100

V. Operator's name, mailing address (if different from name of facility owner):
Mr. Radford Jenkins Telephone number: (864) 304-9275

VI. Landowner's name, mailing address (if different from name of facility or operator):
Wasteco, Inc. Telephone number: (864) 223-0100

VII. I have placed my signature and seal upon the documents submitted with this application signifying that I accept responsibility for the information and/or design contained therein. Additional submittals where required will also bear my signature and seal, signifying that I accept responsibility for the information and/or design contained therein.
Engineer's name (print): Ryan T. Ohmer Signature: [Signature] Registered Professional Engineer
S.C. Registration No: 35683

VIII. I have read this application and all attached documents. I agree to the requirements and conditions that are contained in it. Also, I agree to the admission of properly authorized persons at all reasonable hours for the purpose of sampling and inspection.
Name of Facility Representative (print): Radford Jenkins Signature: [Signature]
Facility Representative's title: U.P. Date: 10-10-19
Name of Operator Representative (print): (If different from facility representative) Signature:
Operator Representative's title: Date:
Name of Landowner (print): (if different from facility or operator representative) Signature:
Date:

**POST-CLOSURE CARE ESTIMATE  
FOR THE  
GREENPOINTE CLASS II C&D LANDFILL  
CELL ONE  
October 2, 2019**

TASK	UNIT	QUANTITY	ANNUAL QUANTITY	UNIT COST	ESTIMATED ANNUAL COSTS	ESTIMATED COSTS FOR REMAINING TERM OF CARE PERIOD <sup>1</sup>
<b>GROUNDWATER (Post-Closure 20 Year Period 2038 Through 2058*)</b>						
Semiannual Groundwater Class II C&D Sampling & Analysis	EA	6	1	\$ 700.00	\$ 4,000.00	\$ 114,000.00
Semiannual Groundwater Class II C&D Monitoring Report	EA	1	1	\$ 8,500.00	\$ 8,500.00	\$ 228,500.00
Annual Groundwater Class II C&D Sampling & Analysis	EA	6	1	\$ 700.00	\$ 4,000.00	\$ 114,000.00
Annual Groundwater Class II C&D Monitoring Report	EA	1	1	\$ 9,000.00	\$ 9,000.00	\$ 251,000.00
Repair/Replacement Groundwater Monitoring Well (1 Event Each)	EA	2	1	\$ 5,000.00	\$ 10,000.00	\$ 10,000.00
<b>Groundwater Subtotal</b>					<b>\$ 25,500.00</b>	<b>\$ 707,500.00</b>
<b>INSPECTION OF MAINTENANCE AND COVER (THROUGH 2058)</b>						
Maintenance of Cover (Mowing, Repair, and Re-vegetation)	AC	30	2	\$ 335.00	\$ 20,000.00	\$ 548,000.00
Annual Visual Observation	LS	1	1	\$ 1,000.00	\$ 1,000.00	\$ 45,500.00
<b>I &amp; M Subtotal</b>					<b>\$ 21,000.00</b>	<b>\$ 593,500.00</b>
<b>OTHER ITEMS</b>						
Annual NPDES Permitting (Sampling & Review)	LS	1	1	\$ 3,500.00	\$ 3,500.00	\$ 93,500.00
Preliminary Engineering Report - NPDES Permit (1 Event)	LS	1	1	\$ 6,000.00	\$ 6,000.00	\$ 6,000.00
Final Engineering Report - NPDES Permit (1 Event)	LS	1	1	\$ 8,000.00	\$ 8,000.00	\$ 8,000.00
Erosion and Sediment Control	LS	1	1	\$ 6,000.00	\$ 6,000.00	\$ 160,000.00
Stormwater Basin Maintenance	EA	3	2	\$ 2,500.00	\$ 15,000.00	\$ 411,000.00
<b>Other Items Subtotal</b>					<b>\$ 38,500.00</b>	<b>\$ 678,500.00</b>
<b>SUBTOTAL</b>					<b>\$ 85,000.00</b>	<b>\$ 1,979,500.00</b>
Contingency					\$ 8,500.00	\$ 198,000.00
<b>TOTAL</b>					<b>\$ 93,500.00</b>	<b>\$ 2,177,500.00</b>

Notes:

1. Estimates account for fluctuations caused by inflation of 2-1/2% during the 20-year post closure care period beginning in 2038.
2. Estimates are based on the current SCDHEC Regulation 61-107.19 effective May 23, 2008.
3. Estimate associated with NPDES Permitting Services anticipates services being required until end of closure period for C&D Landfill through 2058 and does not include provisions for coordination and completion of additional services associated with permit limit exceedence.

\* Assuming a 30-Year Lifetime for the Landfill and that waste placement began in 2008.

**POST-CLOSURE CARE ESTIMATE  
FOR THE  
GREENPOINTE CLASS II C&D LANDFILL  
CELL TWO  
October 2, 2019**

TASK	UNIT	QUANTITY	ANNUAL QUANTITY	UNIT COST	ESTIMATED ANNUAL COSTS	ESTIMATED COSTS FOR REMAINING TERM OF CARE PERIOD <sup>1</sup>
<b>GROUNDWATER (Post-Closure 20 Year Period 2051 Through 2071*)</b>						
Semiannual Groundwater Class II C&D Sampling & Analysis	EA	4	1	\$ 1,300.00	\$ 5,000.00	\$ 126,000.00
Semiannual Groundwater Class II C&D Monitoring Report	EA	1	1	\$ 14,000.00	\$ 14,000.00	\$ 314,500.00
Annual Groundwater Class II C&D Sampling & Analysis	EA	4	1	\$ 1,300.00	\$ 5,000.00	\$ 126,000.00
Annual Groundwater Class II C&D Monitoring Report	EA	1	1	\$ 15,000.00	\$ 15,000.00	\$ 346,000.00
Repair/Replacement Groundwater Monitoring Well (1 Event Each)	EA	2	1	\$ 5,000.00	\$ 10,000.00	\$ 10,000.00
<b>Groundwater Subtotal</b>					<b>\$ 39,000.00</b>	<b>\$ 912,500.00</b>
<b>INSPECTION OF MAINTENANCE AND COVER (THROUGH 2071)</b>						
Maintenance of Cover (Mowing, Repair, and Re-vegetation)	AC	18	2	\$ 550.00	\$ 20,000.00	\$ 453,000.00
Annual Visual Observation	LS	1	1	\$ 3,000.00	\$ 3,000.00	\$ 63,000.00
<b>I &amp; M Subtotal</b>					<b>\$ 23,000.00</b>	<b>\$ 516,000.00</b>
<b>OTHER ITEMS</b>						
Annual NPDES Permitting (Sampling & Review)	LS	1	1	\$ 3,500.00	\$ 3,500.00	\$ 129,000.00
Preliminary Engineering Report - NPDES Permit (1 Event)	LS	1	1	\$ 6,000.00	\$ 6,000.00	\$ 6,000.00
Final Engineering Report - NPDES Permit (1 Event)	LS	1	1	\$ 8,000.00	\$ 8,000.00	\$ 8,000.00
Erosion and Sediment Control	LS	1	1	\$ 6,000.00	\$ 6,000.00	\$ 220,500.00
Stormwater Basin Maintenance	EA	3	2	\$ 3,500.00	\$ 21,000.00	\$ 566,500.00
<b>Other Items Subtotal</b>					<b>\$ 23,500.00</b>	<b>\$ 930,000.00</b>
<b>SUBTOTAL</b>					<b>\$ 85,500.00</b>	<b>\$ 2,358,500.00</b>
Contingency					\$ 8,500.00	\$ 236,000.00
<b>TOTAL</b>					<b>\$ 94,000.00</b>	<b>\$ 2,594,500.00</b>

Notes:

1. Estimates account for fluctuations caused by inflation of 2-1/2% during the 20-year post closure care period beginning in 2051.
2. Estimates are based on the current SCDHEC Regulation 61-107.19 effective May 23, 2008.
3. Estimate associated with NPDES Permitting Services anticipates services being required until end of closure period for C&D Landfill through 2071 and does not include provisions for coordination and completion of additional services associated with permit limit exceedence.

\* Assuming a 13-Year Lifetime for the Landfill and that waste placement will begin in 2038.

Greenpointe Construction and Demolition Debris Landfill (Cell 1)  
Preliminary Cost Estimate  
Anderson County  
South Carolina

C&D Landfill Cell One - Closure					
No.	Quantity	Unit	Item Description	Unit Price	Total
1	78,000	SY	Fine Grading Cover Slopes	\$5.00	\$ 390,000
2	760	LF	12" HDPE Pipe (Single Wall)	\$40.00	\$ 30,400
3	200	SY	Outlet Protection	\$60.00	\$ 12,000
4	78,000	SY	Erosion Control Matting	\$3.00	\$ 234,000
5	30	AC	Grassing	\$3,500.00	\$ 105,000
				<b>Subtotal:</b>	<b>\$ 771,400</b>
				Contingency:	\$ 73,100
				Surveying:	\$ 17,500
				Engineering Design:	\$ 78,000
				Bidding and Award:	\$ 7,500
				Construction Administration/Observation:	\$ 62,000
				<b>Total:</b>	<b>\$ 1,009,500</b>

Notes:

1. All costs are 2019 costs based on \$53/barrel for crude oil.
2. Unit cost for earthwork assumes that finish grade elevations will be within one (1) foot of permitted elevations and that no import or removal of material is necessary.
3. The costs included within are for both labor and materials.
4. Total cost values based on assumption of yearly inflation rate of 2-1/2%.
5. Remaining life expectancy of C&D Landfill is approximately nineteen (19) years.

Greenpointe Construction and Demolition Debris Landfill (Cell 2)  
Preliminary Cost Estimate  
Anderson County  
South Carolina

C&D Landfill Cell Two - Closure					
No.	Quantity	Unit	Item Description	Unit Price	Total
1	50,000	SY	Fine Grading Cover Slopes	\$5.00	\$ 250,000
2	280	LF	12" HDPE Pipe (Single Wall)	\$40.00	\$ 11,200
3	125	SY	Outlet Protection	\$60.00	\$ 7,500
4	50,000	SY	Erosion Control Matting	\$3.00	\$ 150,000
5	18	AC	Grassing	\$3,500.00	\$ 63,000
				<b>Subtotal:</b>	<b>\$ 481,700</b>
				Contingency:	\$ 45,800
				Surveying:	\$ 17,500
				Engineering Design:	\$ 50,000
				Bidding and Award:	\$ 4,500
				Construction Administration/Observation:	\$ 40,000
				<b>Total:</b>	<b>\$ 639,500</b>

Notes:

1. All costs are 2019 costs based on \$53/barrel for crude oil.
2. Unit cost for earthwork assumes that finish grade elevations will be within one (1) foot of permitted elevations and that no import or removal of material is necessary.
3. The costs included within are for both labor and materials.
4. Total cost values based on assumption of yearly inflation rate of 2-1/2%.
5. Remaining life expectancy of C&D Landfill is approximately thirteen (13) years.

# SITE HYDROGEOLOGIC CHARACTERIZATION REPORT EXPANSION AREA

GREENPOINTE CLASS 2 LANDFILL  
500 HAMLIN ROAD  
EASLEY, ANDERSON COUNTY,  
SOUTH CAROLINA  
SC SOLID WASTE PERMIT #LF2-00001

**Prepared For:**  
Greenpointe Landfill, LLC  
P.O. Box 8028  
Greenville, South Carolina 29604

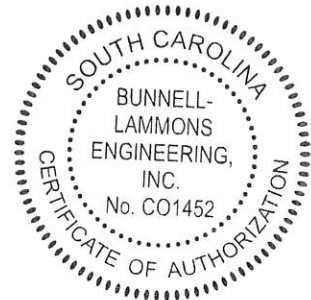

BLE Project Number J18-11684-02

May 16, 2019



**BLE**

**BUNNELL  
LAMMONS  
ENGINEERING**

6004 Ponders Court | Greenville, SC 29615  
864.288.1265 864.288.4330 info@blecorp.com  
**BLECORP.COM**



**BUNNELL  
LAMMONS  
ENGINEERING**

May 16, 2019

Mr. Radford Jenkins  
Greenpoint Landfill, LLC  
PO Box 8028  
Greenville, South Carolina, 29604-8028

Attention: Mr. Radford Jenkins

Subject: **Site Hydrogeologic Characterization Report – Expansion Area  
Greenpoint Class 2 Landfill**  
SC Solid Waste Permit # LF2-00001  
500 Hamlin Road  
Easley, Anderson County, South Carolina  
BLE Project Number J18-11684-02

Dear Mr. Jenkins:

Bunnell Lammons Engineering, Inc. (BLE) is pleased to present this *Site Hydrogeologic Characterization Report* for the proposed expansion to the Greenpoint Class 2 Landfill located in Anderson County, South Carolina. This report is being submitted in general accordance with South Carolina Department of Health and Environmental Control (SCDHEC) Regulation R. 61-107.19, Part IV [Class 2 Landfills] Subpart B [Locations Restrictions] and portions of D [Design Criteria].

We appreciate the opportunity to serve as your geological and geotechnical consultant on this project and look forward to continuing to work with you at the Greenpoint Class 2 Landfill. If you have any questions, please contact us at (864) 288-1265.

Sincerely,

BUNNELL LAMMONS ENGINEERING, INC.

  
Daniel P. Osbourne, P.G.  
Senior Hydrogeologist  
Registered, South Carolina #2376



  
Mark S. Preddy, P.G.  
Senior Hydrogeologist  
Registered, South Carolina #1111

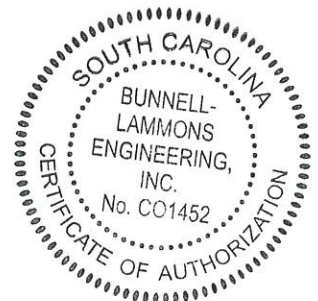
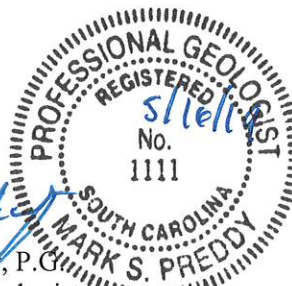



## TABLE OF CONTENTS

<b>1.0</b>	<b>PROJECT INFORMATION .....</b>	<b>1</b>
<b>2.0</b>	<b>GEOLOGIC SETTING AND LITERATURE REVIEW .....</b>	<b>2</b>
2.1	Regional Geology .....	2
2.2	Regional Hydrogeology .....	2
2.3	Physiographic and Topographic Setting .....	3
2.4	Soil Survey.....	3
<b>3.0</b>	<b>FIELD INVESTIGATION METHODOLOGY.....</b>	<b>4</b>
3.1	Area Reconnaissance .....	4
3.2	Site Reconnaissance.....	4
3.3	Groundwater Investigation.....	4
3.4	Soil Laboratory Testing .....	5
<b>4.0</b>	<b>RESULTS OF INVESTIGATION .....</b>	<b>6</b>
4.1	Area Reconnaissance .....	6
4.2	Subsurface Conditions .....	6
4.3	Soil Laboratory Testing Results.....	6
4.4	Site Hydrogeology .....	7
4.4.1	Precipitation Data and Seasonal Groundwater Level Trends .....	7
4.4.2	Water Table Elevation and Groundwater Flow Direction .....	8
4.4.3	Influences to Groundwater Levels .....	8
4.4.4	Hydraulic Coefficients and Groundwater Flow Velocity .....	8
4.4.4.1	Hydraulic Conductivity.....	9
4.4.4.2	Hydraulic Gradient.....	9
4.4.4.3	Effective Porosity and Specific Yield.....	9
4.4.4.4	Groundwater Flow Velocity .....	9
<b>5.0</b>	<b>LOCATION RESTRICTIONS.....</b>	<b>10</b>
5.1	Buffer Zones .....	10
5.1.1	Nearby Residences and Public Facilities .....	10
5.1.2	Floodplains.....	10
5.1.3	Wetlands .....	10
5.1.4	Site Access.....	10
5.1.5	Property Boundaries.....	11
5.1.6	Surface Water Bodies .....	11
5.1.7	Residential Wells .....	11
5.1.8	Utilities.....	11
5.2	Airport Safety .....	12
<b>6.0</b>	<b>BIBLIOGRAPHY .....</b>	<b>13</b>



**Tables**

Table 1	Piezometer and Piezotube Survey Information
Table 2	Piezometer Construction Details
Table 3	Groundwater Depth and Elevation Data
Table 4	Summary of In-Situ Hydraulic Testing – Slug Test Results
Table 5	Summary of Laboratory Results
Table 6	Interstitial Groundwater Flow Velocity Calculations

**Figures**

Figure 1	Site Location Map
Figure 2	Proposed Expansion Area
Figure 3	Potentiometric Surface Map – January 31, 2019
Figure 4	Composite High Potentiometric Surface Map
Figure 5	Geologic Profile A-A'
Figure 6	Geologic Profile B-B'
Figure 7	Geologic Profile C-C'

**Appendices**

Appendix A	SCDHEC Work Plan Approval Letter
Appendix B	Piezometer Installation Procedures and Boring Logs
Appendix C	Slug Test Procedures and Data
Appendix D	Soil Laboratory Test Procedures and Results
Appendix E	Historical Precipitation Data Summary

## 1.0 PROJECT INFORMATION

The existing Greenpointe Class 2 Landfill is located on about nine miles north of Williamston, at 500 Hamlin Road in Anderson County, South Carolina (**Figure 1**). The landfill is identified as South Carolina Solid Waste Permit #LF2-00001. Greenpointe Landfill, LLC (GPL) operates the landfill and is currently evaluating the possibility of an expansion outside the existing approximate 20-acre landfill footprint. The proposed expansion areas consist of approximately 8 acres located adjacent to the west of the side of the current landfill area (Expansion Area A) and approximately 15 acres located roughly 500-feet to the east of the current landfill area (Expansion Area B). The proposed expansion areas were not part of the facility's original solid waste permit. The proposed expansion will result in a total landfill area of approximately 43 acres (**Figure 2**). The proposed expansion footprint and base grades have been preliminarily designed by Alliance Consulting Engineers (Alliance). The new landfill footprint would include two new sediment ponds and a new, approximately 23-acre soil borrow area.

Previous geological studies performed at the site include:

- *Construction, Demolition, and Land Clearing Debris Landfill Plan for the Greenpointe C&D Landfill Site, Revision 3*, Davis & Floyd Inc., May 2008.
- *Groundwater Detection Monitoring Plan*, David & Floyd Inc., August 2009.
- *Revised Groundwater Detection Monitoring Plan*, HRP Associates Inc., April 2015.
- *Semiannual Groundwater Monitoring Reports*, March 2010-Present.

A *Site Hydrogeologic Characterization Study Work Plan* (Work Plan), dated September 20, 2017 was prepared by BLE to address SCDHEC Regulation R.61-107.19, Part IV [Class 2 Landfills], Subpart B [Locations Restrictions] and portions of D [Design Criteria]. The Work Plan included the proposed scope of work, general methodologies, and boring layout for this detailed site hydrogeologic characterization report contained herein. SCDHEC approved the hydrogeological Work Plan on October 17, 2017 (see **Appendix A**).

## 2.0 GEOLOGIC SETTING AND LITERATURE REVIEW

### 2.1 Regional Geology

The subject site is located within the Inner Piedmont Belt of the Piedmont Physiographic Province (Piedmont) and is generally characterized by weathered residual material overlying crystalline bedrock that occurs in northeast-southwest trending geologic belts. The bedrock in the area of the site consists primarily of migmatitic granitoid gneiss (*Horton and Dicken 2001*).

The typical residual soil profile in the Piedmont consists of clayey and silty soils near the surface, where soil weathering is more advanced. The residual soil profile generally becomes coarser with depth. The near surface clayey and silty soils are underlain by micaceous sandy silts and silty sands. Residual soil zones develop by the *in-situ* chemical weathering of bedrock and are commonly referred to as “saprolite.” Saprolite usually consists of sand with lesser amounts of silt, clay, and large rock fragments. The thickness of the saprolite in the Piedmont ranges from a few feet to more than 100 feet.

A transitional zone of partially weathered rock is normally found below the saprolite and overlying the parent bedrock. Partially weathered rock is defined, for engineering purposes, as residual material with standard penetration resistance (ASTM 1586) in excess of 100 blows per foot (bpf). Fractures, joints, and the presence of less resistant rock types facilitate weathering. Consequently, the profile of the partially weathered rock and hard rock is quite irregular and erratic, even over short horizontal distances. Also, it is not unusual to find lenses and boulders of hard rock and zones of partially weathered rock within the soil mantle, well above the general bedrock level.

### 2.2 Regional Hydrogeology

Groundwater in the Piedmont usually occurs as unconfined, water-table aquifers in four primary geologic zones: 1) alluvial soils deposited in flood plains of streams and rivers; 2) residual soil (saprolite); 3) partially weathered rock; and 4) fractured bedrock (*Horton and Zullo 1991*). These zones are typically interconnected through open fractures and pore spaces. The configuration of the water-table aquifer generally resembles the local topography.

In the alluvial/residual soil and partially weathered rock zones, groundwater is stored within the pore spaces and is released to the underlying bedrock through gravity drainage. Groundwater within the bedrock zone occurs primarily in fracture voids. Generally, fractures within the bedrock are very small, but may extend to several hundred feet and may intersect other fractures forming complex, interconnected fracture networks.

Infiltration of precipitation to recharge the water-table aquifer is primarily affected by rainfall intensity and duration, soil characteristics (lithology), pre-existing soil moisture conditions, temperature (evaporation), plant uptake (transpiration), and separation between ground surface and the unconfined water-table. Seasonal high water-tables are typically observed during the late winter and early spring months of the year when maximum infiltration efficiency occurs due to lower temperatures and less plant transpiration (i.e. many plants are dormant). Seasonal low water-tables are typically observed during the summer and fall months when minimum infiltration efficiency occurs due to higher temperatures and greater plant transpiration.

### 2.3 Physiographic and Topographic Setting

The topography of the site generally consists of rolling hills and ravines. The highest site elevations, which are approximately 900 feet above mean sea level (msl), are located in the northern portion of the existing landfill. In the proposed expansion area, the highest elevations (860 feet msl) are located in northeastern corner of the proposed expansion (*USGS Topographic Maps, 7.5 Minute Series, Easley, Five Forks, Liberty, and Piercetown Quadrangles*). The lowest site elevations, which are about 800 feet msl, are located in the central southern portion of the Site, in a wetland area (*U.S. Department of Interior, National Wetland Inventory Map*). The total relief across the site is approximately 100 feet.

The site is primarily covered by hardwood and pine timber of varying ages and logging trails extend throughout the site along the higher elevations and ridgelines. The surface drainage pattern at the site is generally composed of short, linear, interconnected drainage features which drain primarily toward the center of the Site, between the existing Class 2 landfill and the proposed expansion area. The flow converges into an unnamed tributary in the center of the site that flows southward toward Pickens Creek. The site is located within the Three and Twenty Creek Watershed, which is ultimately part of the Savannah River Basin (*SCDHEC Bureau of Water, Watershed Atlas*).

### 2.4 Soil Survey

Soil survey data for the site prepared by the United States Department of Agriculture (USDA) and Natural Resources Conservation Service (NRCS) were reviewed to obtain additional information on the surficial soils at the proposed expansion site. The dominant soil series present across the site are Cecil, Hiwassee, Wilkes, and Cataula. The following Soil Series information was obtained from the USDA *Soil Survey of Anderson County, South Carolina*, along with the official soil series descriptions (<http://soils.usda.gov/technical/classification.html>).

The Cecil Series consist generally of well drained, moderately permeable sandy loam and clay soils that occur on ridges and side slopes of the Piedmont uplands. These soils are formed in residuum that is derived from the weathering of felsic, igneous, and high-grade metamorphic rocks. Slopes typically range from 0 to 25 percent.

The Hiwassee Series consists generally of very deep, well drained soils on high stream terraces in the Piedmont. These soils formed in old alluvium derived from felsic and mafic rocks. Slopes range from 0 to 25 percent.

The Wilkes Series consist generally of well drained, moderately to low permeable sandy loam, clay, and clay loam soils that occur in the uplands of the Piedmont. These soils are formed in residuum that is derived from the weathering of intermediate and mafic crystalline rocks. Slopes typically range from 4 to 60 percent.

The Cataula Series soils consist primarily of moderately well drained, low permeable sandy loam and clay underlain by sandy clay loam and clay loam at depth, are formed in residuum that is derived from the weathering of metamorphic and igneous rocks of the Piedmont. Cataula Series soils are characterized by dense, brittle, horizontal layers of alternating sandy clay loam and clay loam present from approximately 27 to 55 inches below ground surface (at the type section) and are often cross-cut by vertical strata of clay and clay loam. Slopes typically range from 2 to 25 percent.

### 3.0 FIELD INVESTIGATION METHODOLOGY

A *Site Hydrogeologic Characterization Study Work Plan* (Work Plan), dated September 20, 2017 was prepared by BLE to address SCDHEC Regulation R.61-107.19, Part IV [Class 2 Landfills], Subpart B [Locations Restrictions] and portions of D [Design Criteria]. The Work Plan included the proposed scope of work, general methodologies, and boring layout for this detailed site hydrogeologic characterization report contained herein. SCDHEC approved the hydrogeological Work Plan on October 17, 2017 (see **Appendix A**).

A discussion of the project investigative methodology is provided below. The field activities reported below were performed under the direction of a South Carolina licensed geologist.

#### 3.1 Area Reconnaissance

An area reconnaissance was performed by Alliance Consulting Engineers (Alliance). The reconnaissance included areas within 1,000-feet of the facility boundary to locate residences, day-care centers, schools, churches, hospitals, and publicly-owned parks. Additionally, the reconnaissance included the location of public and private drinking water supplies, including reservoirs and wells within 100-feet of the site boundaries.

#### 3.2 Site Reconnaissance

A BLE geologist traversed the site on foot monthly between January 2018 and January 2019 to observe springs, drainage features, rock outcrops, and other features that may affect site suitability or the ability to monitor groundwater quality effectively at the site.

#### 3.3 Groundwater Investigation

Twelve (12) new piezometers (PZ-14 through PZ-25) were installed in the proposed expansion area between December 4, 2017 through March 23, 2018 to monitor water table elevations and further characterize the study area hydrogeology. These are in addition to eleven (11) pre-existing piezometers associated with the existing Class 2 landfill. Boring logs for the newly installed piezometers are provided in **Appendix B**. Survey information is presented on **Table 1** and piezometer construction details are summarized on **Table 2**.

Water levels were measured in the twelve (12) new piezometers and nine (9) of the eleven (11) pre-existing piezometers on a monthly basis from January 2018 through January 2019. The two (2) pre-existing piezometers that were not sampled had been abandoned prior to March 2010. The historical groundwater levels are summarized on **Table 3**.

Field permeability (slug) tests were performed on five (5) piezometers in the expansion area to measure the *in situ* hydraulic conductivity of different units of the water table aquifer. Slug test data are presented in **Appendix C** and are summarized on **Table 4**.

To determine if the unnamed on-site stream is discharging or recharging four (4) piezotubes (PT-1 through PT-4) were installed in the streambeds to observe baseflow discharges. The piezotubes consist of 3/4-inch inside diameter (1-inch outside diameter) galvanized steel pipe with an expendable tip. The piezotubes were driven using a manual hammer approximately two feet below the base of the stream channel. Once the desired depth was reached, the piezotube was retracted approximately 1/4-foot. Then a steel rod was inserted through the piezotube to the top of the expendable tip. The expendable tip was then dislodged from

the base of the piezotube by hammering the steel rod. The bottom of the piezotube was thereby exposed, allowing the inflow of groundwater. The steel rod was then removed and the piezotube was checked to make sure that groundwater had entered the piezotube. After the water levels had stabilized, the water elevation inside the tubes was compared to the stream water elevation and ground elevation outside the tubes to determine that the streams are recharging or discharging.

The piezometers and piezotubes are only for investigation use and not intended be part of the permanent groundwater monitoring system. Prior to cell construction, the piezometers may be abandoned in accordance with applicable SCDHEC regulations.

### 3.4 Soil Laboratory Testing

Laboratory tests were conducted to confirm the field classifications and quantify pertinent engineering soil properties. Soil samples were collected using split-spoon samplers, Shelby tubes (undisturbed), and from the auger cuttings (bulk samples). The laboratory tests were performed in general accordance with applicable ASTM specifications, where available. Brief descriptions of the test procedures are included in **Appendix D**. Soil laboratory results are included in **Appendix D** and are summarized in **Table 5**.

## 4.0 RESULTS OF INVESTIGATION

### 4.1 Area Reconnaissance

An area reconnaissance was performed by Alliance and will be submitted under a separate cover. At the time of this report, Alliance has not notified BLE of any residences, day-care centers, schools, churches, hospitals, or publicly-owned parks within 1,000-feet of the facility boundary. In addition, BLE has not been notified of any public or private drinking water supplies, including reservoirs and wells within 100-feet of the site boundaries.

### 4.2 Subsurface Conditions

Twelve (12) new soil test borings (PZ-14 through PZ-25) were performed on the expansion area. In general, the borings were advanced between 14 and 40 feet below the ground surface. Auger refusal was encountered in one boring, PZ-24, at a depth of 14 feet below ground surface. The soils encountered while drilling were alluvial sediments or residual soils derived from the in-place chemical weathering of the underlying gneiss and schist bedrock in the surrounding region.

Alluvial soils are present along the floodplain of the unnamed tributary in the center of the site, which defines the western boundary of the expansion area. Where encountered during drilling (PZ-14 and PZ-15), these soils consisted of very soft and very micaceous sandy-silt. Field and laboratory USCS classifications of these soils are SM and SC-SM. Where encountered, this component ranges in thickness from 3.0 to 4.0 feet. Standard penetration resistance values (N-values) range from weight of the hammer to 1, indicating a very loose average consistency.

The shallow residual soil component consists of slightly micaceous sandy-silts, silty-sand, clayey-sand, and high plasticity clays. Field and laboratory USCS classifications of these soils are SM, SC, MH, CH, and SW-SM. The shallow residual soil component grades with depth into a deeper residual soil component that is coarser-grained, less plastic, micaceous sandy-silt, sandy-silty-clay and silty-sand, which extends to the borehole termination depth or the depth of the partially weathered rock and/or auger refusal. Field and laboratory USCS classifications of these soils are mostly CL and SM. N-values for residual soils were 13 or less, indicating a loose average consistency.

Subsurface geology in the proposed expansion area is shown on three cross sections designated A-A', B-B' and C-C' (**Figure 5, Figure 6 and Figure 7**). Soil boring logs showing visual descriptions of the soil strata encountered are included in **Appendix B**.

### 4.3 Soil Laboratory Testing Results

Laboratory testing of soil samples was performed to measure pertinent engineering and hydrogeologic parameters. Four (4) undisturbed (Shelby tube) samples and 10 split spoon samples were tested in the laboratory. The test results are summarized on **Table 5** and the test procedures and data sheets are included in **Appendix D**. Laboratory results of the different soil components are described below.

Testing results of the samples collected from the alluvial component consisted of:

- Natural moisture content values ranging from 15.4 to 53.3 percent;
- Liquid Limit (LL) values ranging from 21 to 55;
- Plasticity Index (PI) values ranging from 5 to 6;
- Average gravel, sand, silt, and clay contents of 0.8, 68.7, 15.8, and 14.6 percent, respectively;
- Total porosity values ranging from 40.8 to 41.9 percent; and

- Effective porosity values ranging from 18.6 to 19.1 percent.

Testing results of the samples collected from the shallow residual soil component consisted of:

- Natural moisture content values ranging from 7.3 to 39.8 percent;
- LL values ranging from 35 to 83;
- PI values ranging from 2 to 45;
- Average gravel, sand, silt, and clay contents of 0.9, 52.3, 15.2, and 31.6 percent, respectively;
- Hydraulic conductivity values ranging from  $9.8 \times 10^{-7}$  to  $8.1 \times 10^{-4}$  cm/sec;
- Total porosity values ranging from 35.1 to 57.2 percent; and
- Effective porosity values ranging from 19.5 to 26.6 percent.

Testing results of the samples collected from the deeper residual soil component consisted of:

- Natural moisture content values ranging from 32.6 to 41.2 percent;
- LL values ranging from 39 to 49;
- PI values ranging from 6 to 14;
- Average gravel, sand, silt, and clay contents of 0.4, 56.7, 28.6, and 14.3 percent, respectively;
- Total porosity values ranging from 42.3 to 48.9 percent; and
- Effective porosity values ranging from 18.6 to 26.6 percent.

#### 4.4 Site Hydrogeology

Twelve (12) new piezometers and four (4) new piezotubes were installed on the expansion area at locations shown on **Figure 3**. Additionally, there are nine (9) pre-existing piezometers associated with the existing Class 2 landfill. The water-table aquifer consists of the residual saprolitic soil. In the lower elevation areas the thin alluvial sediments in the drainages also make up a small portion of the water table aquifer. These units are hydraulically connected and thus comprise a single unconfined aquifer, although recharge rates, flow rates and storativity differ between the units based on the unique geologic conditions of each zone. The configuration of the water table surface is a subdued replica of the ground surface (**Figure 3**). Generally, shallow groundwater flows toward the south. A description of the hydrogeologic conditions at the site is provided below.

##### 4.4.1 Precipitation Data and Seasonal Groundwater Level Trends

The relationship between precipitation and groundwater level trends at the site was evaluated from 2010 to 2018. Historical groundwater elevations are summarized in **Table 3**. The following sources of data were used to evaluate the seasonal high water level at the site:

1. Historical National Oceanic and Atmospheric Administration (NOAA) precipitation data were obtained to establish seasonal trends for the Anderson County area (<https://www.ncdc.noaa.gov/cdo-web/datasets.html>);
2. Historical water level measurements from March 2010 to January 2019 from piezometers for the existing landfill and expansion area.

Historical NOAA monthly precipitation data were obtained from weather station US1SCP0014 for the period of January 2013 through December 2018 and are summarized in **Appendix E**. The data are summarized seasonally such that January-March represents *winter*, April-June represents *spring*, July-September represents *summer*, and October-December represents *fall*.



Based on the NOAA precipitation data, the winter and spring months experienced the most precipitation in the general area of landfill. Additionally, the winter and spring months typically experience maximum water infiltration efficiency to recharge the uppermost aquifer because the effects of evapotranspiration are limited (i.e., cooler weather and less plant uptake). Because of these natural trends, the amount of groundwater recharge and subsequent increase in the water table level is typically greatest during winter and spring months of January through June.

#### 4.4.2 Water Table Elevation and Groundwater Flow Direction

Groundwater level elevations were measured in the new piezometers and piezotubes on the expansion area and the piezometers around the existing landfill from January 2018 to January 2019 (**Table 3**). In addition, semi-annual groundwater elevations measurements from March 2010 to September 2017 for piezometers around the existing landfill are also provided on **Table 3**. A Composite High Groundwater Potentiometric Surface Map (**Figure 4**) was prepared representing the composite potentiometric surface of the highest groundwater elevation measured from each piezometer, monitoring well, and piezotube from March 2010 to January 2019.

The groundwater elevation varied across the site from a minimum elevation of 795.86 feet above msl (PZ-4) in September 2018 to 839.39 feet above msl (PZ-20) in January 2019. Of the 25 groundwater measuring points (21 piezometers and 4 piezotubes) all but four of them (PZ-1, PZ-24, PT-2, and PT-3) had their highest recorded groundwater elevation during the January 2019 sampling event.

Groundwater at the existing landfill site and the expansion area flows toward the south and has a configuration similar to natural topography as indicated on the January 3, 2019 potentiometric surface map (**Figure 3**). Overall, there is a north-south trending topographic low traversing through the center of the site. Likewise, groundwater flows from the current landfill and the proposed expansion area toward the center of the site.

Groundwater flow is through the soil matrix, the weathered fracture openings, and the bedrock fractures. Recharge to the unconfined aquifer occurs at the higher elevations. Based on the data collected from the 4 piezotubes, groundwater discharge occurs on site into the perennial streams and wetlands.

#### 4.4.3 Influences to Groundwater Levels

Natural influences on groundwater levels at the site are a result of the combined effects of precipitation and evapotranspiration. Seasonal high-water levels typically occur during the late winter and spring months, and seasonal low water levels typically occur during the fall months.

Currently, no manmade activities exist on the expansion area that could significantly influence the groundwater levels in the uppermost aquifer. As landfill cell construction proceeds onto the expansion area, groundwater infiltration and recharge to the water table aquifer will be limited, resulting in lower groundwater levels.

#### 4.4.4 Hydraulic Coefficients and Groundwater Flow Velocity

The velocity of groundwater flow is derived from the equation (*Fetter 2001*):

$$V = \frac{Ki}{n_e}$$

Where

$V$  is the flow velocity;  
 $K$  is the hydraulic conductivity;  
 $i$  is the hydraulic gradient; and  
 $n_e$  is the effective porosity.

Estimated values for these parameters are provided below and summarized on **Tables 4, 5, and 6**.

#### 4.4.4.1 Hydraulic Conductivity

Hydraulic conductivity is defined as the ability of the aquifer material to conduct water under a hydraulic gradient. Five (5) slug tests were performed in piezometers in the expansion area (PZ-15, PZ-16, PZ-18, PZ-20, and PZ-23) to measure the in situ hydraulic conductivity of the water-bearing zone of the water-table aquifer (**Table 4**). The slug test results were evaluated using the *Bouwer and Rice Method (1976)* for partially-penetrating wells in an unconfined aquifer (**Appendix C**).

Based on the slug test results from across the expansion area, hydraulic conductivity measurements range from  $2.67 \times 10^{-5}$  cm/sec (PZ-18) to  $1.10 \times 10^{-3}$  cm/sec (PZ-23).

#### 4.4.4.2 Hydraulic Gradient

The hydraulic gradient is determined by dividing the difference in potentiometric head elevations at two locations by the horizontal distance between those locations along the direction of groundwater flow. Hydraulic gradients were measured from the January 3, 2019 water level measurements (**Figure 3**).

The steepest hydraulic gradient measured in the study area is approximately 0.065 ft/ft (near PZ-17 and PZ-18) and the shallowest hydraulic gradient measured in the study area is approximately 0.021 ft/ft (near PZ-11 and PZ-12).

#### 4.4.4.3 Effective Porosity and Specific Yield

Effective porosity is the volume of void spaces through which water or other fluids can travel in soil divided by the total volume of the soil. Effective porosity can be assumed to be approximately equal to specific yield. Specific yield is defined as the ratio of the volume of water that drains from saturated sediment owing to the attraction of gravity to the total volume of soil. The laboratory grain size analyses were used to derive values for specific yield and effective porosity (**Table 5** and **Appendix D**).

Based on soil laboratory data and published geologic literature, effective porosity measurements are as follows for the site:

- 18.6% to 19.1% (average = 18.9%) in the alluvium;
- 19.5% to 26.6% (average = 23.3%) in shallow residual soil; and
- 18.6% to 19.5% (average = 19.1%) in the deep residual soil.

#### 4.4.4.4 Groundwater Flow Velocity

Based on the hydraulic parameters and data provided above, the horizontal movement of groundwater across the site is approximately 0.0266 to 0.502 (average 0.0931) feet/day.

The maximum and minimum values for each unit represent a range of values using available data. **Table 6** summarizes the groundwater flow velocity calculations.

## 5.0 LOCATION RESTRICTIONS

BLE has performed an evaluation of location restrictions as required by SCDHEC regulation *R.61-107.19, Part IV [Class 2 Landfills], Subpart B [Location Restrictions]* with regards to buffers and airport safety. The results of our evaluation are provided below and follow the indicated subheadings from the SCDHEC regulations.

### 5.1 Buffer Zones

#### 5.1.1 Nearby Residences and Public Facilities

*“The boundary of the fill area shall not be located within 1,000 feet of any residence, school, day-care center, church, hospital, or publicly owned recreational park area. The Department will determine whether the new landfill or expansion of an existing landfill meets this requirement prior to the publication of the Notice of Intent to File a Permit Application pursuant to Part I, Section D.1 of this Regulation.”*

A vehicular reconnaissance was performed by Alliance along the roads within 1000 feet surrounding the Greenpointe Landfill and the proposed expansion area. It is BLE’s understanding that the reconnaissance did not locate any to locate residences, day-care centers, schools, churches, hospitals, or publicly-owned parks within 1,000-feet of the Greenpointe Landfill or the proposed expansion area. We understand that Alliance will provide documentation for this Rule separate from this report.

#### 5.1.2 Floodplains

*“A landfill located in a 100-year floodplain shall demonstrate that engineering measures have been incorporated into the landfill design to ensure the landfill will not restrict the flow of the 100-year flood, reduce the temporary water storage capacity of the flood plain, minimize potential for floodwaters coming into contact with waste, or result in the washout of solid waste so as to pose a hazard to human health or the environment.”*

Portions of Pickens Creek along the southern property boundary of the proposed expansion area are prone to the 100-year flood according to the Federal Emergency Management Agency. Therefore, the design of the proposed waste disposal area will consider the location of the 100-year floodplain, and no landfill facilities or structures will be located in the 100-year floodplain. The approximate extent of the 100-year floodplain as defined by F&S Surveyors, Engineers and Planners, Inc. (F&S) is shown in **Figure 3**.

#### 5.1.3 Wetlands

*“The landfill shall be in compliance with applicable requirements concerning wetlands imposed by the U.S. Army Corps of Engineers, the U.S. Environmental Protection Agency, and the Department.”*

Two (2) wetland areas have been identified in the central portion of the Site, between the current landfill and the proposed expansion area. The design of the proposed waste disposal area will consider the wetland areas and maintain appropriate buffer setbacks, unless they can be mitigated. A map showing the approximate extent of the two wetland areas as defined by F&S is provided in **Figure 3**.

#### 5.1.4 Site Access

*“Access to the landfill shall be controlled through the use of fences, gates, berms, natural barriers, or other means to prevent promiscuous dumping and unauthorized access.”*

Access to the active landfill area and the proposed expansion area is currently controlled to prevent unauthorized access.

#### 5.1.5 Property Boundaries

*“The boundary of the fill area shall not be located within 100 feet of any property line. An exemption may be issued by the Department upon receipt of written approval from adjacent property owners.”*

The design of the landfill waste units on the proposed expansion area will not be within the 100-foot limit from any property boundary not under control by the landfill.

#### 5.1.6 Surface Water Bodies

*“The boundary of the fill area shall not be located within 200 feet of any surface water that holds visible water for greater than six consecutive months, excluding drainage ditches, sedimentation ponds and other operational features on the site”.*

The design of the landfill waste units on the proposed expansion area will be closer than 200-feet from any surface water that holds visible water for greater than six consecutive months, excluding ditches, sediment ponds, and other operational features on the Site. Surface water bodies would include portions of Pickens Creek along the southern property boundary of the proposed expansion area and the two (2) wetland areas have been identified in the central portion of the Site, between the current landfill and the proposed expansion area.

#### 5.1.7 Residential Wells

*“The boundary of the fill area shall not be located within 100 feet of any drinking water well. A greater buffer may be required for compliance with the Department's Bureau of Water requirements.”*

A vehicular reconnaissance was performed by Alliance along the roads within 100 feet surrounding the Greenpointe Landfill and the proposed expansion area. It is BLE's understanding that no residences were identified within 100-feet of the existing landfill or the proposed expansion area that utilize a drinking water well. We understand that Alliance will provide documentation for this Rule separate from this report.

#### 5.1.8 Utilities

*“Waste material shall not be placed on or within any property rights-of-way or 50 feet of underground or above ground utility equipment or structures, i.e., water lines, sewer lines, storm drains, telephone lines, electric lines, natural gas lines, etc., without the written approval of the impacted utility.”*

Based on the 2018 F&S survey, an underground telephone right-of-way runs across the proposed expansion area (**Figure 3**). The design of the landfill waste units on the proposed expansion area, as prepared by Alliance, should not be within the 50-foot limit from the telephone utility right-of-way. This restriction can be mitigated if the telephone utility right-of-way and any associated underground telephone lines are relocated outside of the waste cell footprint.

No other utility right-of-way is located within 50-feet of the proposed expansion area.

## 5.2 Airport Safety

*“a. Owners/operators of all Class Two landfills located within 10,000 feet of any runway end used by turbojet aircraft or within 5,000 feet of any airport runway end used by only piston-type aircraft shall demonstrate that the units are designed and operated so that the Class Two landfill does not pose a bird hazard to aircraft.*

*b. Owners/operators proposing to site new Class Two landfills and lateral expansions located within a five mile radius of any airport runway end used by turbojet or piston-type aircraft shall notify the affected airport and the Federal Aviation Administration (FAA).”*

A search of: 1) the Atlanta Sectional Aeronautical Chart prepared by the National Oceanic and Atmospheric Association; 2) the FAA Aeronautical Information Services (AIS) online database of airports; and 3) Google Earth identified the following as the closest airport to the existing Greenpointe Landfill and the proposed expansion area:

- Davis Field (location identifier: 4SC4) is a private airport with a grass landing strip located approximately 4.9 miles northwest of the existing Greenpointe Landfill property. Davis Field does not have a control tower.

## 6.0 BIBLIOGRAPHY

- Bouwer, H. and Rice, R.C., 1976, *A slug test method for determining hydraulic conductivity of unconfined aquifers with completely or partially penetrating wells*, Water Resources Research, Vol. 12, No. 3, pp. 423-428.
- Bunnell-Lammons Engineering, Inc., September 20, 2017, *Site Hydrogeologic Characterization Work Plan*, BLE Project Number J17-11684-01.
- Davis & Floyd Inc., May 2008, *Construction, Demolition, and Land Clearing Debris Landfill Plan for the Greenpointe C&D Landfill Site, Revision 3*, Davis & Floyd Inc. Job Number 11967.00.
- David & Floyd Inc., August 2009, *Groundwater Detection Monitoring Plan*, Davis & Floyd Inc. Job Number 11967.00.
- Fetter, C.W., 2001, *Applied Hydrogeology (Fourth Edition)*: Merrill Publishing Company, Columbus, Ohio.
- Horton, J.W., and Dicken, C.L., 2001, *Preliminary Geologic Map of the Appalachian Piedmont and Blue Ridge, South Carolina Segment*; United States Geological Survey Open-File Report 01-298, CD.
- Horton, J.W. and Zullo, V.A., 1991, *The Geology of the Carolinas: Carolina Geological Society fifteenth anniversary volume*: The University of Tennessee Press, Knoxville, TN.
- HRP Associates Inc., April 13, 2015. *Revised Groundwater Detection Monitoring Plan*, HRP Associates Inc., Job Number GRE4713.GW.
- National Oceanic and Atmospheric Association, Atlanta Sectional Aeronautical Chart, 102<sup>nd</sup> Edition effective February 28, 2019 to August 15, 201
- National Wetlands Inventory Map; United States Department of the Interior, Fish, and Wildlife Service, Interactive internet database search
- South Carolina Department of Health and Environmental Control, April 26, 2002, *South Carolina Well Standards* (Regulations 61-71).
- United States Department of Agriculture Soil Conservation Service and Natural Resources Conservation Service, Official Soil Series Descriptions, <http://soils.usda.gov/technical/classification/osd/index.html>.
- United States Geological Survey Topographic Maps, 7.5 Minute Series, Easley, Five Forks, Liberty, and Piercetown, Quadrangles

# TABLES

**TABLE 1****PIEZOMETER AND PIEZOTUBE SURVEY INFORMATION****Greenpointe Class 2 Landfill Expansion****Anderson County, South Carolina****BLE Project Number J18-11684-02**

<b>Piezometer/ Piezotube</b>	<b>Ground Elevation</b>	<b>TOC Elevation</b>	<b>Northing</b>	<b>Easting</b>
<b>PZ-1</b>	854.49	857.20	1,057,386.75	1,515,103.91
<b>PZ-2</b>	Abandoned			
<b>PZ-4</b>	801.48	804.60	1,055,843.89	1,515,590.01
<b>PZ-5</b>	824.88	828.20	1,056,313.38	1,515,034.12
<b>PZ-6</b>	819.61	822.90	1,056,778.38	1,514,650.57
<b>PZ-8</b>	813.31	816.30	1,056,479.69	1,515,281.11
<b>PZ-9</b>	Abandoned			
<b>PZ-10</b>	822.29	824.80	1,056,716.39	1,515,042.50
<b>PZ-11</b>	812.11	814.90	1,056,827.47	1,515,794.01
<b>PZ-12</b>	806.82	810.00	1,056,554.68	1,515,876.86
<b>PZ-13</b>	811.82	815.10	1,056,564.40	1,515,617.61
<b>PZ-14</b>	822.99	826.25	1,057,354.99	1,516,013.96
<b>PZ-15</b>	813.03	816.27	1,056,971.77	1,516,053.21
<b>PZ-16</b>	816.24	819.63	1,057,015.20	1,516,206.93
<b>PZ-17</b>	809.76	811.68	1,056,788.52	1,516,339.33
<b>PZ-18</b>	824.02	827.72	1,057,009.87	1,516,522.87
<b>PZ-19</b>	837.05	840.74	1,057,141.47	1,516,807.54
<b>PZ-20</b>	847.19	850.06	1,057,390.47	1,516,845.82
<b>PZ-21</b>	833.02	835.09	1,057,294.79	1,516,442.61
<b>PZ-22</b>	846.99	850.09	1,057,671.60	1,516,281.36
<b>PZ-23</b>	834.58	837.68	1,057,503.88	1,516,156.35
<b>PZ-24</b>	821.40	824.65	1,056,494.33	1,517,089.11
<b>PZ-25</b>	819.71	822.88	1,056,927.02	1,517,190.59
<b>PT-1</b>	816.50	819.89	1,057,273.51	1,515,828.01
<b>PT-2</b>	813.11	814.99	1,057,105.30	1,515,923.82
<b>PT-3</b>	805.62	808.01	1,056,815.16	1,516,052.71
<b>PT-4</b>	802.05	804.63	1,056,561.94	1,516,226.81

**NOTES:**

1. Measurements are in feet; elevations are relative to mean sea level (msl).
2. Northings and Eastings are referenced to the South Carolina Grid.
3. Surveying was performed by F&S Surveyors of Anderson, South Carolina.
4. TOC = Top Of Casing (PVC pipe).



**TABLE 2****PIEZOMETER CONSTRUCTION DETAILS**

**Greenpointe Class 2 Landfill Expansion  
Anderson County, South Carolina  
BLE Project Number J18-11684-02**

Piezometer/ Piezotube	Ground Elev.	TOC Elev.	Auger Refusal		Total Depth	Screened Interval	
			Depth	Elevation		Depth	Elevation
<b>PZ-1</b>	854.49	857.20	>38.8	<815.7	38.81	40.43 - 50.43	814.1 - 804.1
<b>PZ-2</b>	Abandoned						
<b>PZ-4</b>	801.48	804.60	>32.2	<769.3	62.20	52.00 - 62.00	749.5 - 739.5
<b>PZ-5</b>	824.88	828.20	>28.6	<796.3	28.62	38.20 - 48.20	786.7 - 776.7
<b>PZ-6</b>	819.61	822.90	>49.5	<770.1	49.51	39.26 - 49.26	780.4 - 770.4
<b>PZ-8</b>	813.31	816.30	>19.4	<793.9	19.42	48.18 - 58.18	765.1 - 755.1
<b>PZ-9</b>	Abandoned						
<b>PZ-10</b>	822.29	824.80	>22.2	<800.1	22.23	43.91 - 53.91	778.4 - 768.4
<b>PZ-11</b>	812.11	814.90	>23.3	<788.8	23.32	42.15 - 52.15	770.0 - 760.0
<b>PZ-12</b>	806.82	810.00	23.2	783.60	23.22	44.75 - 54.75	762.1 - 752.1
<b>PZ-13</b>	811.82	815.10	>23.4	<788.4	23.38	47.32 - 57.32	764.5 - 754.5
<b>PZ-14</b>	822.99	826.25	>11.2	<811.8	11.20	1.00 - 11.00	822.0 - 812.0
<b>PZ-15</b>	813.03	816.27	>11.7	<801.3	11.70	1.50 - 11.50	811.5 - 801.5
<b>PZ-16</b>	816.24	819.63	>12.3	<803.9	12.30	2.10 - 12.10	814.1 - 804.1
<b>PZ-17</b>	809.76	811.68	>19.0	<790.8	19.00	8.80 - 18.80	801.0 - 791.0
<b>PZ-18</b>	824.02	827.72	>17.1	<806.9	17.10	6.90 - 16.90	817.1 - 807.1
<b>PZ-19</b>	837.05	840.74	>23.3	<813.8	23.30	13.10 - 23.10	824.0 - 814.0
<b>PZ-20</b>	847.19	850.06	>25.5	<821.7	25.50	15.30 - 25.30	831.9 - 821.9
<b>PZ-21</b>	833.02	835.09	>15.6	<817.4	15.60	5.40 - 15.40	827.6 - 817.6
<b>PZ-22</b>	846.99	850.09	>22.5	<824.5	22.50	12.30 - 22.30	834.7 - 824.7
<b>PZ-23</b>	834.58	837.68	>22.5	<812.1	22.50	12.30 - 22.30	822.3 - 812.3
<b>PZ-24</b>	821.40	824.65	14.0	807.40	14.00	3.80 - 13.80	817.6 - 807.6
<b>PZ-25</b>	819.71	822.88	>24.1	<795.6	24.10	13.90 - 23.90	805.8 - 795.8

**NOTES:**

1. Measurements are in feet; elevations are relative to mean sea level (msl).
2. TOC = Top Of Casing
3. Depths are in feet below ground surface.

TABLE 3  
GROUNDWATER DEPTH AND ELEVATION DATA  
Greenpointe Class 2 Landfill Expansion  
Anderson County, South Carolina  
BLE Project Number J18-11684-02

Piezometer/ Piezotube	Ground Elevation	TOC Elevation	Groundwater Elevation Data																			Maximum Elevation	Minimum Elevation	Head Difference																									
			3/9/10	8/19/10	3/21/11	8/11/11	3/16/12	9/11/12	3/4/13	9/10/13	2/26/14	8/19/14	3/5/15	9/9/15	3/15/16	8/30/16	3/9/17	9/5/17	1/24/18	2/22/18	3/14/18				5/1/18	6/13/18	6/29/18	7/31/18	8/31/18	9/19/18	10/30/18	11/26/18	1/3/19																
PZ-1	854.49	857.20	830.04	828.23	827.34	826.79	827.37	826.61	827.10	830.05	830.57	829.93	830.85	830.10	832.77	831.45	830.55	830.28	829.87	830.56	830.78	830.95	831.15	830.99	830.59	830.41	830.02	829.56	830.44	831.59	832.77	826.61	6.16																
PZ-2															Abandoned																																		
PZ-4	801.48	804.60	NM	NM	NM	NM	NM	NM	NM	NM	NM	NM	NM	NM	NM	NM	NM	NM	797.45	798.03	798.30	798.00	797.45	797.32	796.45	796.21	795.86	796.13	798.32	800.51	800.51	795.86	4.65																
PZ-5	824.88	828.20	NM	NM	NM	NM	NM	NM	NM	NM	NM	NM	NM	NM	800.03	804.76	799.45	Dry	Dry	800.53	802.20	802.95	802.40	803.67	803.23	802.36	802.22	801.45	800.58	802.81	806.68	806.68	799.45	7.23															
PZ-6	819.61	822.90	NM	NM	NM	NM	NM	NM	NM	NM	NM	NM	NM	NM	NM	NM	NM	NM	818.20	818.10	818.53	817.68	816.04	815.31	813.64	813.45	812.19	813.61	818.88	819.19	819.19	812.19	7.00																
PZ-8	813.31	816.30	NM	NM	NM	NM	NM	NM	NM	NM	NM	NM	NM	NM	798.88	803.49	799.54	800.01	799.52	800.82	803.23	803.74	803.25	803.00	802.34	800.76	800.23	799.99	799.06	802.92	809.32	798.88	10.44																
PZ-9															Abandoned																																		
PZ-10	822.29	824.80	815.92	809.44	814.45	808.84	815.32	812.42	816.09	815.58	816.63	812.35	817.03	811.80	816.29	811.20	814.09	811.86	814.50	816.13	816.23	816.00	815.33	814.59	813.52	813.48	812.69	812.68	816.08	817.78	817.78	808.84	8.94																
PZ-11	812.11	814.90	NM	NM	NM	NM	NM	NM	NM	NM	NM	NM	NM	NM	807.57	809.19	807.61	808.64	809.20	809.39	809.46	809.57	809.07	808.92	807.97	807.73	808.06	808.12	809.56	810.30	810.30	807.52	2.78																
PZ-12	806.82	810.00	NM	NM	NM	NM	NM	NM	NM	NM	NM	NM	NM	NM	797.94	800.84	798.15	799.71	798.01	800.37	801.24	801.33	801.05	800.47	800.15	798.99	798.59	798.38	798.77	801.23	803.08	803.08	797.94	5.14															
PZ-13	811.82	815.10	NM	NM	NM	NM	NM	NM	NM	NM	NM	NM	NM	NM	798.39	801.66	798.19	799.60	798.45	800.09	801.91	802.14	801.82	801.62	800.77	799.72	799.39	798.68	798.73	801.41	805.30	805.30	798.19	7.11															
PZ-14	822.99	826.25	NP	NP	NP	NP	NP	NP	NP	NP	NP	NP	NP	NP	NP	NP	NP	NP	822.18	822.35	822.42	822.20	821.78	821.92	821.15	820.92	821.51	821.59	822.54	822.87	822.92	820.92	1.95																
PZ-15	813.03	816.27	NP	NP	NP	NP	NP	NP	NP	NP	NP	NP	NP	NP	NP	NP	NP	NP	811.33	811.62	811.57	811.35	810.62	812.78	810.53	809.68	809.53	809.69	810.11	811.59	812.38	809.53	2.85																
PZ-16	816.24	819.63	NP	NP	NP	NP	NP	NP	NP	NP	NP	NP	NP	NP	NP	NP	NP	NP	815.19	815.49	815.82	815.61	814.03	813.81	812.15	811.84	811.48	812.84	815.52	815.83	815.83	811.48	4.35																
PZ-17	809.76	811.68	NP	NP	NP	NP	NP	NP	NP	NP	NP	NP	NP	NP	NP	NP	NP	NP	802.29	803.04	803.48	803.48	802.49	801.78	800.56	800.12	799.36	799.81	803.08	804.17	804.17	799.36	4.81																
PZ-18	824.02	827.72	NP	NP	NP	NP	NP	NP	NP	NP	NP	NP	NP	NP	NP	NP	NP	NP	817.89	821.04	821.66	821.17	816.50	815.18	814.11	813.82	813.47	813.83	820.84	822.70	822.70	813.47	9.23																
PZ-19	837.05	840.74	NP	NP	NP	NP	NP	NP	NP	NP	NP	NP	NP	NP	NP	NP	NP	NP	822.58	825.32	825.84	826.10	824.78	823.45	821.95	821.35	820.73	819.65	823.51	827.98	827.98	819.65	8.33																
PZ-20	847.19	850.06	NP	NP	NP	NP	NP	NP	NP	NP	NP	NP	NP	NP	NP	NP	NP	NP	829.95	833.55	834.86	835.66	834.92	833.52	831.29	830.26	828.93	827.70	832.53	839.39	839.39	827.70	11.69																
PZ-21	833.02	835.09	NP	NP	NP	NP	NP	NP	NP	NP	NP	NP	NP	NP	NP	NP	NP	NP	827.67	829.11	829.45	829.58	828.46	827.28	825.31	824.62	823.08	823.32	828.19	836.45	836.45	823.08	7.37																
PZ-22	846.99	850.09	NP	NP	NP	NP	NP	NP	NP	NP	NP	NP	NP	NP	NP	NP	NP	NP	833.41	834.15	834.55	834.57	834.35	834.03	833.59	833.35	833.01	832.99	834.15	835.95	835.95	832.99	2.96																
PZ-23	834.58	837.68	NP	NP	NP	NP	NP	NP	NP	NP	NP	NP	NP	NP	NP	NP	NP	NP	828.68	829.72	829.67	829.58	828.86	828.48	828.01	827.91	827.79	828.03	829.75	831.53	831.53	827.79	3.74																
PZ-24	821.40	824.65	NP	NP	NP	NP	NP	NP	NP	NP	NP	NP	NP	NP	NP	NP	NP	NP	NP	NP	NP	NP	NP	Dry	Dry	Dry	Dry	Dry	Dry	808.54	808.54	808.54	0.00																
PZ-25	819.71	822.88	NP	NP	NP	NP	NP	NP	NP	NP	NP	NP	NP	NP	NP	NP	NP	NP	NP	NP	NP	NP	NP	NP	NP	NP	NP	NP	NP	NP	NP	NP	NP	NP															
PT-1	816.50	819.89	NP	NP	NP	NP	NP	NP	NP	NP	NP	NP	NP	NP	NP	NP	NP	NP	817.12	817.10	817.12	817.02	816.88	817.23	816.75	816.90	816.90	816.88	817.17	817.37	817.37	816.75	0.62																
PT-2	813.11	814.99	NP	NP	NP	NP	NP	NP	NP	NP	NP	NP	NP	NP	NP	NP	NP	NP	813.65	813.52	813.63	813.57	813.51	814.14	813.53	813.41	813.46	813.53	813.60	813.79	814.14	813.41	0.73																
PT-3	805.62	808.01	NP	NP	NP	NP	NP	NP	NP	NP	NP	NP	NP	NP	NP	NP	NP	NP	806.04	805.89	806.22	806.65	807.01	807.27	807.04	807.21	807.39	807.76	807.89	807.89	807.57	807.89	805.89	2.00															
PT-4	802.05	804.63	NP	NP	NP	NP	NP	NP	NP	NP	NP	NP	NP	NP	NP	NP	NP	NP	802.06	802.16	802.17	802.13	801.88	802.21	801.60	801.34	802.07	802.04	802.11	802.26	802.26	801.34	0.92																

Piezometer/ Piezotube	Ground Elevation	TOC Elevation	Depth to Water Below Ground Surface																													
			3/9/10	8/19/10	3/21/11	8/11/11	3/16/12	9/11/12	3/4/13	9/10/13	2/26/14	8/19/14	3/5/15	9/9/15	3/15/16	8/30/16	3/9/17	9/5/17	1/24/18	2/22/18	3/14/18	5/1/18	6/13/18	6/29/18	7/31/18	8/31/18	9/19/18	10/30/18	11/26/18	1/3/19		
PZ-1	854.49	857.20	24.45	26.26	27.15	27.70	27.12	27.88	27.39	24.44	23.92	24.56	23.64	24.39	21.72	23.04	23.94	24.21	24.62	23.93	23.71	23.54	23.34	23.50	23.90	24.47	24.93	24.05	22.90			
PZ-2	Abandoned																															
PZ-4	801.48	804.60	NM	NM	NM	NM	NM	NM	NM	NM	NM	NM	NM	NM	NM	NM	NM	NM	4.03	3.45	3.18	3.48	4.03	4.16	5.03	5.27	5.62	5.35	3.16	0.97		
PZ-5	824.88	828.20	NM	NM	NM	NM	NM	NM	NM	NM	NM	NM	NM	NM	24.85	20.12	25.43	Dry	Dry	24.35	22.68	21.93	22.48	21.21	21.65	22.52	22.66	23.43	24.30	22.07	18.20	
PZ-6	819.61	822.90	NM	NM	NM	NM	NM	NM	NM	NM	NM	NM	NM	NM	NM	NM	NM	NM	1.41	1.51	1.08	1.93	3.57	4.30	5.97	6.16	7.42	6.00	0.73	0.42		
PZ-8	813.31	816.30	NM	NM	NM	NM	NM	NM	NM	NM	NM	NM	NM	NM	14.43	9.82	13.77	13.30	13.79	12.49	10.08	9.57	10.06	10.31	10.97	12.55	13.08	13.32	14.25	10.39	3.99	
PZ-9	Abandoned																															
PZ-10	822.29	824.80	6.37	12.85	7.84	13.45	6.97	9.87	6.20	6.71	5.66	9.94	5.26	10.49	6.00	11.09	8.20	10.43	7.79	6.16	6.06	6.29	6.96	7.70	8.77	8.81	9.60	9.61	6.21	4.51		
PZ-11	812.11	814.90	NM	NM	NM	NM	NM	NM	NM	NM	NM	NM	NM	NM	4.54	2.92	4.50	3.47	4.59	2.91	2.72	2.65	2.54	3.04	3.19	4.14	4.38	4.05				

**TABLE 4**

**SUMMARY OF IN-SITU HYDRAULIC TESTING - SLUG TEST RESULTS**

Greenpointe Class 2 Landfill Expansion

Anderson County, South Carolina

BLE Project Number J18-11684-02

Piezometer	Method	Data Type	Hydrogeologic Unit	Hydraulic Conductivity (K)		
				ft/min	cm/sec	ft/day
PZ-15	Bouwer-Rice (1976)	Falling Head	Residuuum	1.00E-03	5.09E-04	1.441
PZ-16	Bouwer-Rice (1976)	Falling Head	Residuuum	1.03E-04	5.21E-05	0.148
PZ-18	Bouwer-Rice (1976)	Falling Head	Residuuum	5.26E-05	2.67E-05	0.076
PZ-20	Bouwer-Rice (1976)	Falling Head	Residuuum	2.76E-04	1.40E-04	0.397
PZ-23	Bouwer-Rice (1976)	Falling Head	Residuuum	2.16E-03	1.10E-03	3.11
<b>Residuuum</b>						
	Maximum Hydraulic Conductivity			2.16E-03	1.10E-03	3.106
	Geometric Mean Hydraulic Conductivity			3.17E-04	1.61E-04	0.457
	Minimum Hydraulic Conductivity			5.26E-05	2.67E-05	0.0757

**NOTES:**

1. K = Hydraulic Conductivity
2. The data were reduced and the hydraulic conductivities calculated using SuperSlug Version 3.2.

**TABLE 5**

**SUMMARY OF LABORATORY RESULTS**

Greenpointe Class 2 Landfill Expansion

Anderson County, South Carolina

BLE Project Number J18-11684-02

Boring	Split Spoon Depth (ft)	Shelby Tube Depth (ft)	Soil Unit	Nat. Moisture Content (%)	Hydraulic Cond. (cm/sec)	Atterberg Limits			Porosity (%)		Grain Size (% by wt)				USCS
						PL	LL	PI	Total	Effective	Gravel	Sand	Silt	Clay	
PZ-14	1.0 - 2.5	-	Alluvium	53.3%	-	49	55	6	41.9%	19.1%	0.0%	68.7%	15.6%	15.7%	SM
PZ-15	3.5 - 5.0	-	Alluvium	15.4%	-	16	21	5	40.8%	18.6%	1.6%	68.8%	16.0%	13.6%	SC-SM
PZ-15	18.5 - 20.0	-	Shallow Residuum	18.5%	-	34	38	4	38.7%	23.6%	6.7%	75.3%	13.1%	4.9%	SM
PZ-16	-	1.5 - 4.0	Shallow Residuum	37.4%	9.8E-07	38	77	39	51.1%	20.4%	0.2%	42.2%	21.2%	36.4%	MH
PZ-17	-	3.0 - 5.0	Shallow Residuum	25.8%	2.3E-07	30	74	44	46.6%	18.6%	0.0%	41.4%	13.9%	44.7%	CH
PZ-18	6.0 - 7.5	-	Shallow Residuum	26.5%	-	32	67	35	55.1%	22.0%	0.0%	33.5%	17.3%	49.2%	CH
PZ-18	28.5 - 30.0	-	Deeper Residuum	32.6%	-	25	39	14	46.5%	18.6%	0.0%	43.9%	34.8%	21.3%	CL
PZ-20	-	10.0 - 12.0	Shallow Residuum	39.8%	2.2E-06	37	51	14	48.9%	19.5%	1.1%	28.1%	30.8%	40.0%	MH
PZ-20	28.5 - 30.0	-	Deeper Residuum	41.2%	-	35	47	12	42.8%	19.5%	1.1%	59.7%	25.5%	13.7%	SM
PZ-21	1.0 - 2.5	-	Shallow Residuum	32.9%	-	38	83	45	57.2%	22.9%	0.5%	29.3%	15.4%	54.8%	MH
PZ-22	-	3.5 - 5.5	Shallow Residuum	11.1%	8.1E-04	33	35	2	40.0%	24.4%	0.0%	89.0%	4.5%	6.5%	SW-SM
PZ-23	6.0 - 7.5	-	Shallow Residuum	25.8%	-	32	59	27	35.1%	26.6%	1.0%	51.4%	13.2%	34.4%	SM
PZ-24	13.5 - 14	-	Shallow Residuum	7.3%	-	NP	NP	NP	40.3%	24.6%	3.0%	82.3%	10.2%	4.5%	SM
PZ-25	28.5 - 30.0	-	Deeper Residuum	40.2%	-	43	49	6	42.3%	19.2%	0.0%	66.5%	25.5%	8.0%	SM

**NOTES:**

1. Effective Porosity (Specific Yield) is based on grain size analyses and Figure 4.11 (Fetter, 1994). ANS = *Area of No Samples*
2. The effective porosity and total porosity was calculated using methodology presented in the EPA's Composite Model for Leachate Migration with Transformation Products Dated April 2003.
3. USCS = Unified Soil Classification System. Refer to **Appendix B** for a description of the abbreviations.

**TABLE 6**

**INTERSTITIAL GROUNDWATER FLOW VELOCITY CALCULATIONS**

Greenpointe Class 2 Landfill Expansion  
Anderson County, South Carolina  
BLE Project Number J18-11684-02

Geologic Unit	Velocity Calculation	Hydraulic Conductivity (K) (feet per day)	Hydraulic Gradient (i) (unitless)	Effective Porosity ( $n_e$ ) (unitless)	Groundwater Flow Velocity (V) (feet per day)
<b>Residuum</b>	Max $K$ , Max $n_e$ , & Min $i$	3.106	0.021	0.266	<b>0.2452</b>
	Geometric Mean $K$ , and Average $n_e$ & $i$	0.457	0.043	0.211	<b>0.0931</b>
	Max $K$ , and Average $n_e$ & $i$	3.106	0.043	0.266	<b>0.502</b>
	Min $K$ , Min $n_e$ , & Max $i$	0.076	0.065	0.186	<b>0.0266</b>

**Notes:**

- Groundwater Flow Velocity is derived from  $V = Ki/n_e$ , where:  
V = Groundwater Flow Velocity, K = Hydraulic Conductivity, i = Hydraulic Gradient, and  $n_e$  = Effective Porosity.
- The hydraulic conductivity values in the Residuum are from slug tests (**Table 4**).
- The effective porosity was calculated using methodology presented in the EPAs Composite Model for Leachate Migration with Transformation Products Dated April 2003.
- Hydraulic gradient information is from the Potentiometric Surface Map -January 2019 (**Figure 3**).  
The steepest hydraulic gradient measured in the study area is approximately 0.065 ft/ft (near PZ-17 and PZ-18).  
The shallowest hydraulic gradient measured in the study area is approximately 0.021 ft/ft (near PZ-11 and PZ-12).

# FIGURES

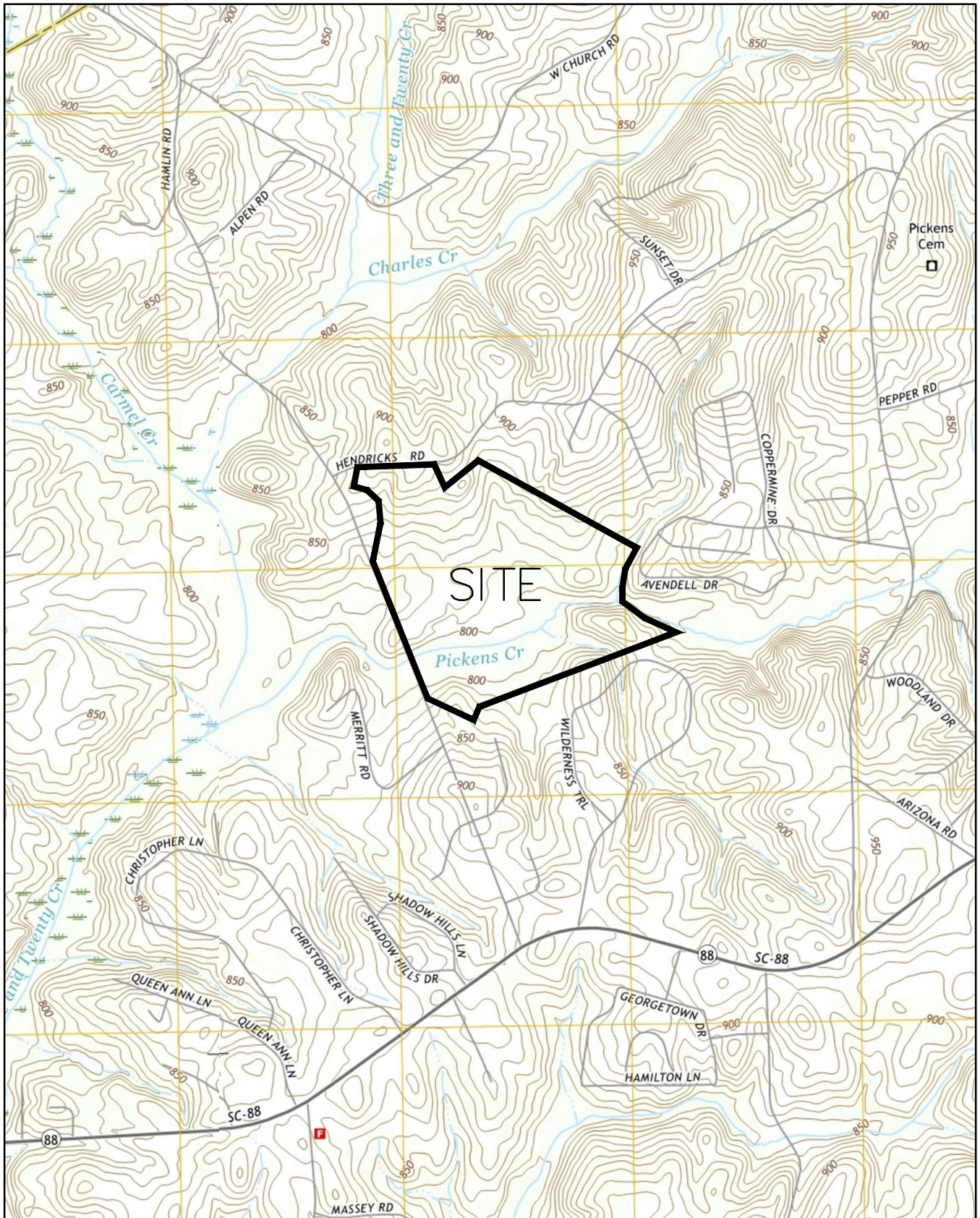

REFERENCE:  
USGS TOPOGRAPHIC MAP, 7.5 MINUTE SERIES,  
EASLEY, FIVE FORKS, LIBERTY AND PIERCETOWN, S.C.  
QUADRANGLES, 2014, 2017, 2014 AND 2014.

DRAWN:	KLW	DATE:	4-26-19
CHECKED:	DPO	CAD:	GREENPOINTE-02SLM
APPROVED:	DBB	JOB NO:	J18-11684-02

**BLE** | **BUNNELL  
LAMMONS  
ENGINEERING**

6004 Ponders Court, Greenville, SC 29615  
Phone: (864) 288-1265 Fax: (864) 288-4430

SITE LOCATION MAP  
GREEN POINTE CLASS 2 LANDFILL  
EASLEY, SOUTH CAROLINA

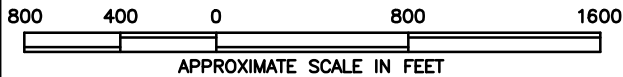
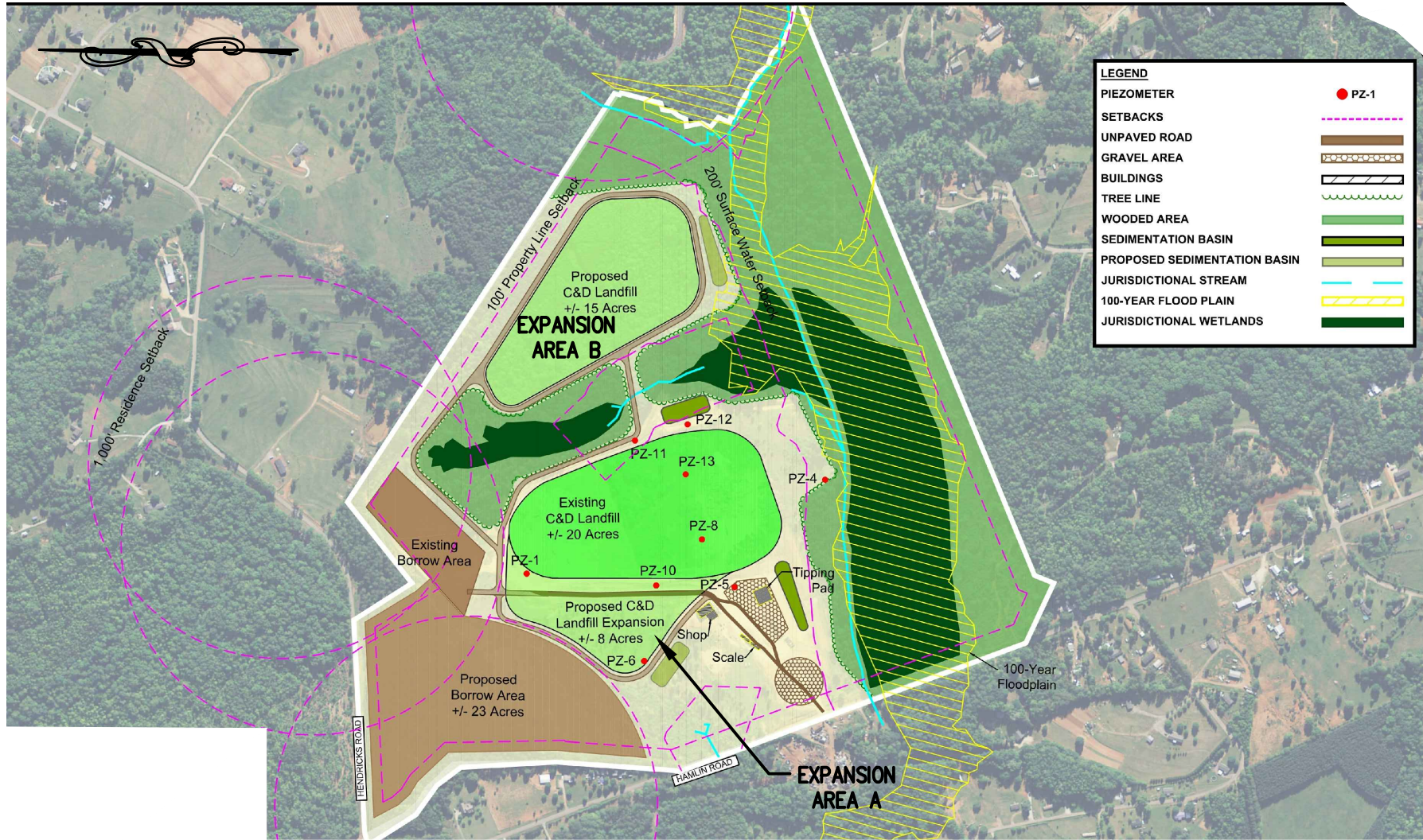

REFERENCE:  
DRAWING TITLED "MASTER DEVELOPMENT PLAN" BY  
ALLIANCE CONSULTING ENGINEERS, INC. DATED JANUARY 13, 2017.

DRAWN:	ACE	DATE:	4-26-19
CHECKED:	DPO	CAD:	GREENPOINTE-02PEA
APPROVED:	DBB	JOB NO:	J18-11684-02

**BLE** | **BUNNELL  
LAMMONS  
ENGINEERING**  
6004 Ponders Court, Greenville, SC 29615  
Phone: (864) 288-1265 Fax: (864) 288-4430

PROPOSED EXPANSION AREAS  
GREENPOINTE CLASS 2 LANDFILL  
EASLEY, SOUTH CAROLINA

FIGURE

**2**



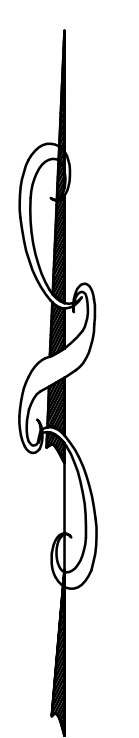
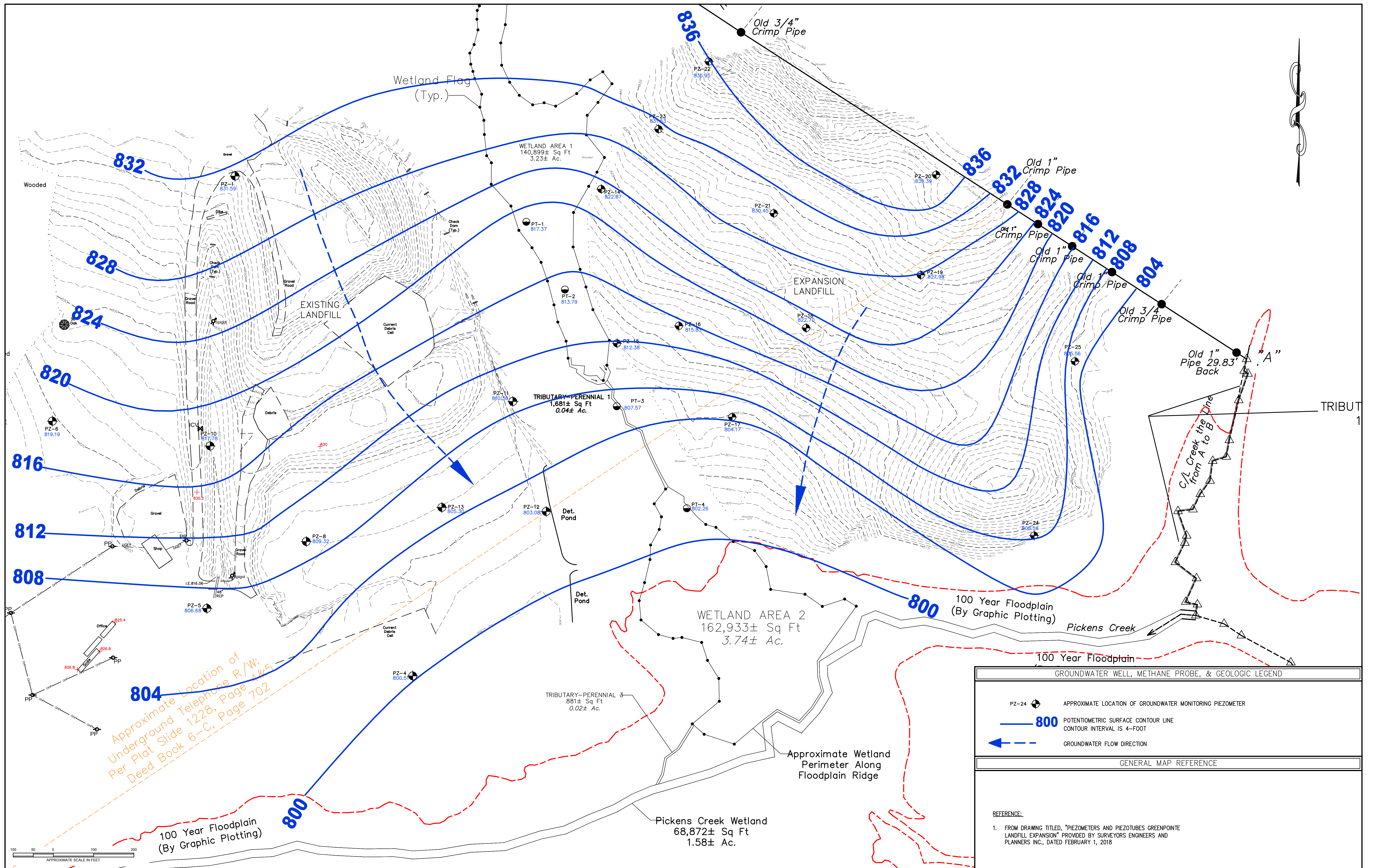

Approximate Location of  
Underground Telephone R/W:  
Per Plat Slide 1228, Page 4&5  
Deed Book 6-C, Page 702

**GROUNDWATER WELL, METHANE PROBE, & GEOLOGIC LEGEND**

- PZ-24 APPROXIMATE LOCATION OF GROUNDWATER MONITORING PIEZOMETER
- 800** POTENTIOMETRIC SURFACE CONTOUR LINE  
CONTOUR INTERVAL IS 4-FOOT
- GROUNDWATER FLOW DIRECTION

**GENERAL MAP REFERENCE**

**REFERENCE:**

- FROM DRAWING TITLED, "PIEZOMETERS AND PIEZOTUBES GREENPOINTE LANDFILL EXPANSION" PROVIDED BY SURVEYORS ENGINEERS AND PLANNERS INC., DATED FEBRUARY 1, 2018

REVISIONS		
No.	DESCRIPTION	BY

<b>DRAWN:</b> IAI	<b>DATE:</b> 4-22-19
<b>CHECKED:</b> DPO	<b>CAD FILE:</b> GREENPOINTE-02WIM019
<b>APPROVED:</b>	<b>JOB NO:</b> J18-11684-02

**BLE** BUNNELL LAMMONS ENGINEERING

6004 Ponders Court, Greenville, SC 29615  
Phone: (864) 288-1265 Fax: (864) 288-4430

POTENTIOMETRIC SURFACE MAP - JANUARY 31, 2019  
GREENPOINTE CLASS II LANDFILL  
ANDERSON COUNTY, SOUTH CAROLINA



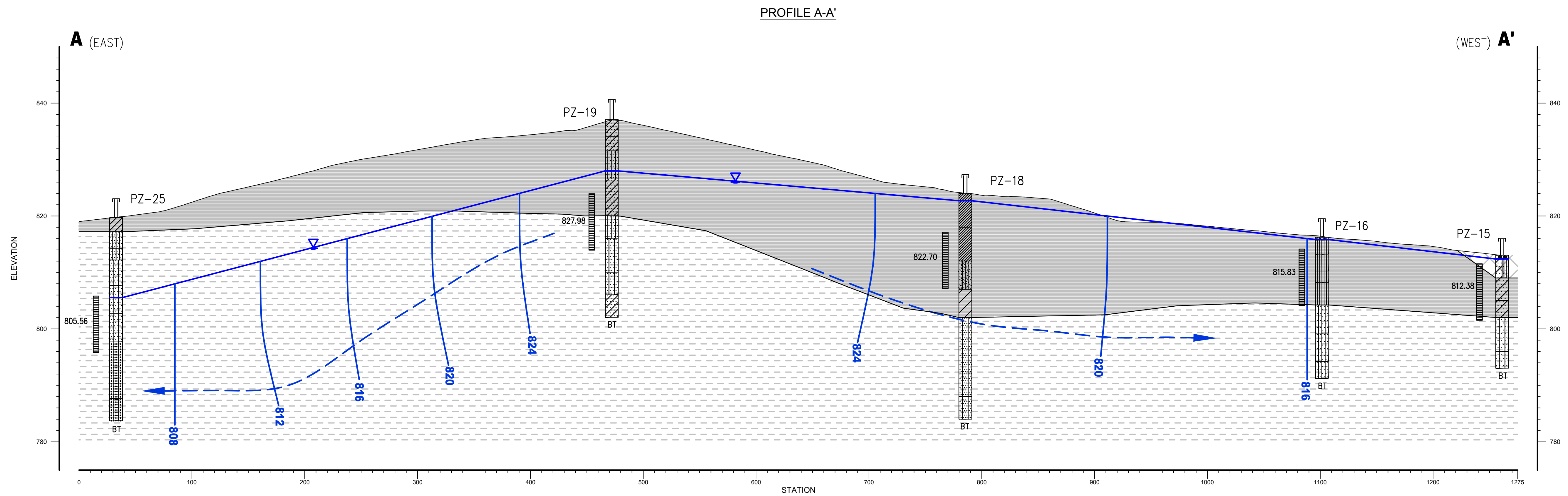

#### PROFILE LEGEND

- EXISTING TOPOGRAPHY
- GROUNDWATER
- SANDY CLAY
- SILTY SAND
- SANDY SILT
- CLAY
- HIGH PLASTICITY CLAY
- CLAYEY SILT
- SAND
- PARTIALLY WEATHERED ROCK
- WATER TABLE SURFACE ON 1-3-19
- 808 EQUIPOTENTIAL LINES (FEET) CONTOUR INTERVAL=4 FEET
- GROUNDWATER FLOW DIRECTION
- BT BORING TERMINATED
- UPPER RESIDUAL SOIL; CLAYEY SAND, CLAYEY SILT AND SILTY CLAY (SC, ML, CH)
- DEEPER RESIDUAL SOIL, SAND SILT AND SILTY SAND (ML, SM)

HORIZONTAL SCALE: 1"=50'  
VERTICAL SCALE: 1"=10'

#### SITE LEGEND

- EXISTING TOPOGRAPHY 1'
- EXISTING TOPOGRAPHY 5'
- ACTIVE CROSS SECTION
- INACTIVE CROSS SECTION
- PIEZOMETERS

#### REFERENCES

- FROM DRAWING TITLED, "PIEZOMETERS AND PIEZOTUBES GREENPOINTE LANDFILL EXPANSION" PROVIDED BY SURVEYORS ENGINEERS AND PLANNERS INC., DATED FEBRUARY 1, 2018

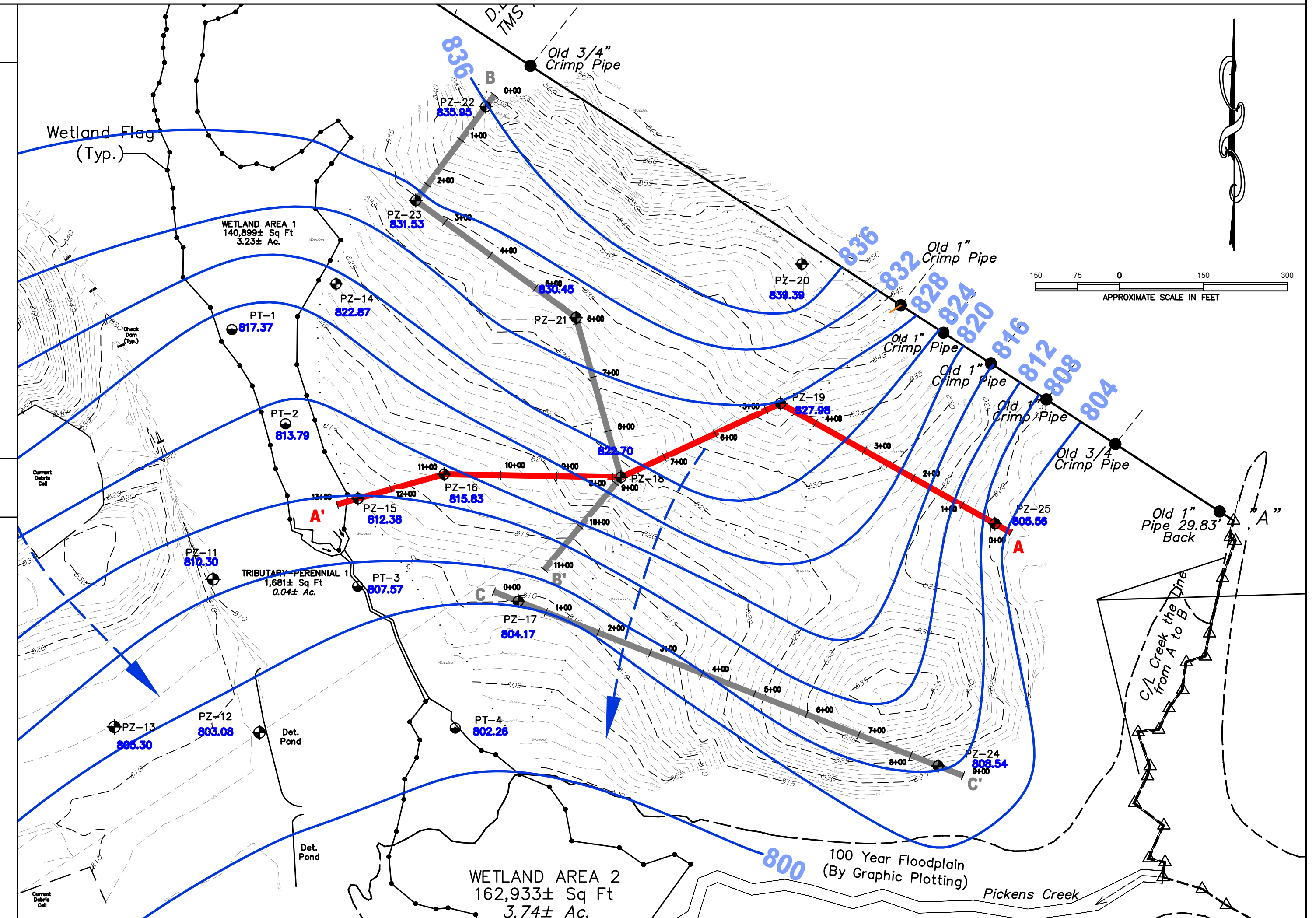

No.	REVISIONS DESCRIPTION	BY

DRAWN: IAI	DATE: 2-26-19
CHECKED: DPO	CAD FILE: GREENPOINTE-02CSLP
APPROVED:	JOB NO: J18-11684-02

**BLE BUNNELL LAMMONS ENGINEERING**  
6004 Ponders Court, Greenville, SC 29615  
Phone: (864) 288-1265 Fax: (864) 288-4430

GEOLOGIC PROFILE A-A'  
GREENPOINTE CLASS II LANDFILL  
ANDERSON COUNTY, SOUTH CAROLINA

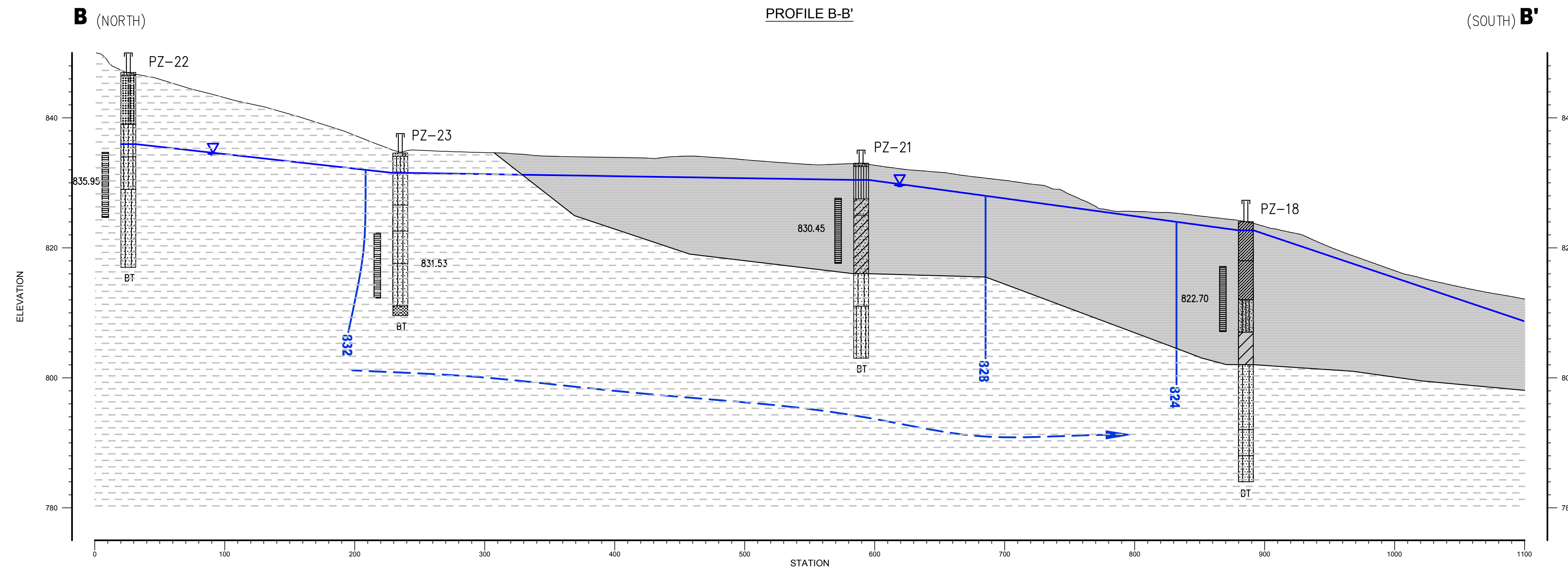

PROFILE LEGEND

- EXISTING TOPOGRAPHY
- GROUNDWATER
- SANDY CLAY
- SILTY SAND
- SANDY SILT
- CLAY
- HIGH PLASTICITY CLAY
- CLAYEY SILT
- SAND
- PARTIALLY WEATHERED ROCK
- WATER TABLE SURFACE ON 1-3-19
- 808 EQUIPOTENTIAL LINES (FEET) CONTOUR INTERVAL=4 FEET
- GROUNDWATER FLOW DIRECTION
- BT BORING TERMINATED
- UPPER RESIDUAL SOIL; CLAYEY SAND, CLAYEY SILT AND SILTY CLAY (SC, ML, CH)
- DEEPER RESIDUAL SOIL, SAND SILT AND SILTY SAND (ML, SM)

HORIZONTAL SCALE: 1"=50'  
VERTICAL SCALE: 1"=10'

SITE LEGEND

- EXISTING TOPOGRAPHY
- ACTIVE CROSS SECTION
- INACTIVE CROSS SECTION
- PIEZOMETERS

REFERENCES

- FROM DRAWING TITLED, "PIEZOMETERS AND PIEZOTUBES GREENPOINTE LANDFILL EXPANSION" PROVIDED BY SURVEYORS ENGINEERS AND PLANNERS INC., DATED FEBRUARY 1, 2018

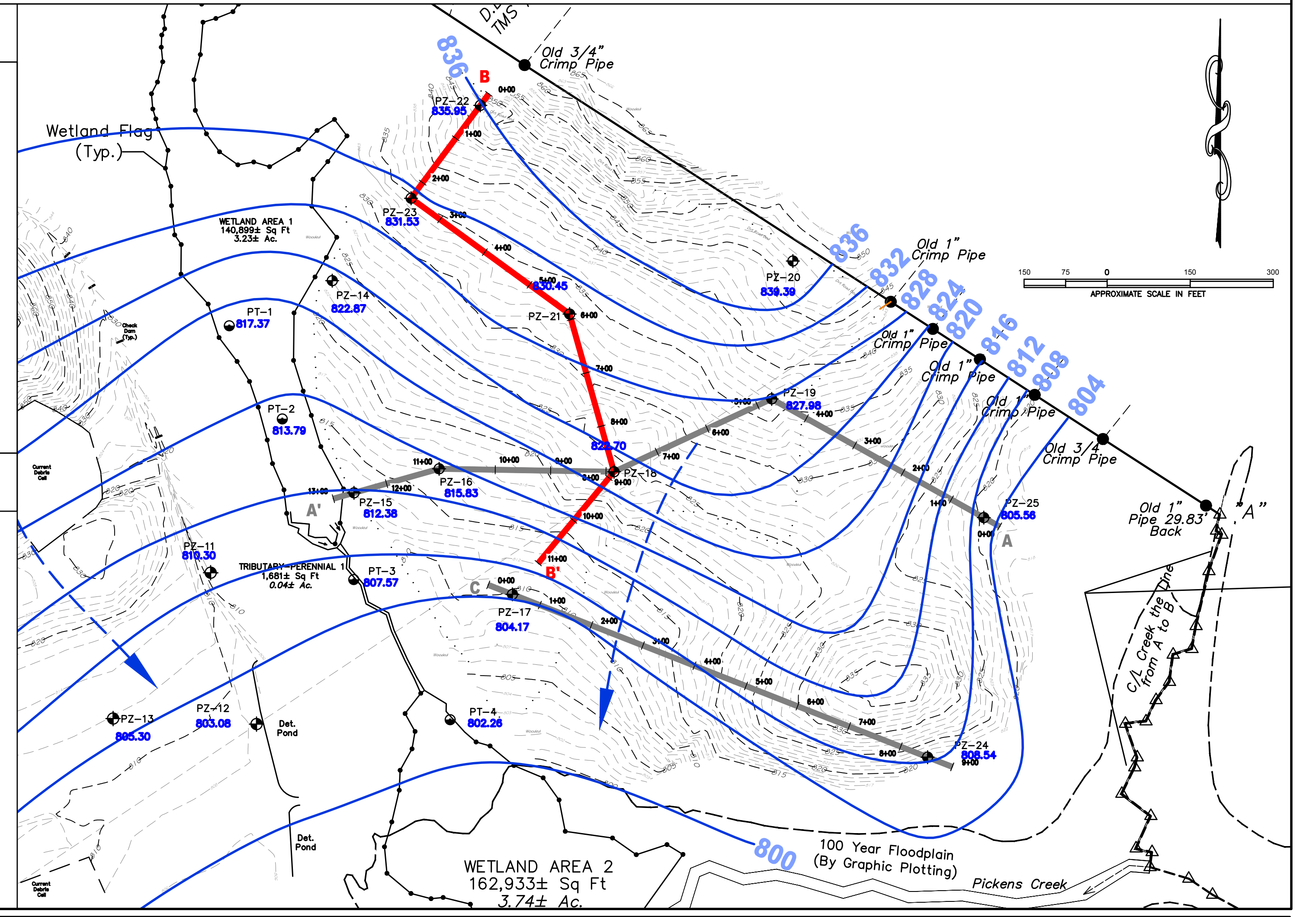

No.	REVISIONS DESCRIPTION	BY

DRAWN: IAI	DATE: 2-26-19
CHECKED: DPO	CAD FILE: GREENPOINTE-02CSLP
APPROVED:	JOB NO: J18-11684-02

**BLE** BUNNELL LAMMONS ENGINEERING  
6004 Ponders Court, Greenville, SC 29615  
Phone: (864) 288-1265 Fax: (864) 288-4430

GEOLOGIC PROFILE B-B'  
GREENPOINTE CLASS II LANDFILL  
ANDERSON COUNTY, SOUTH CAROLINA

PROFILE C-C'

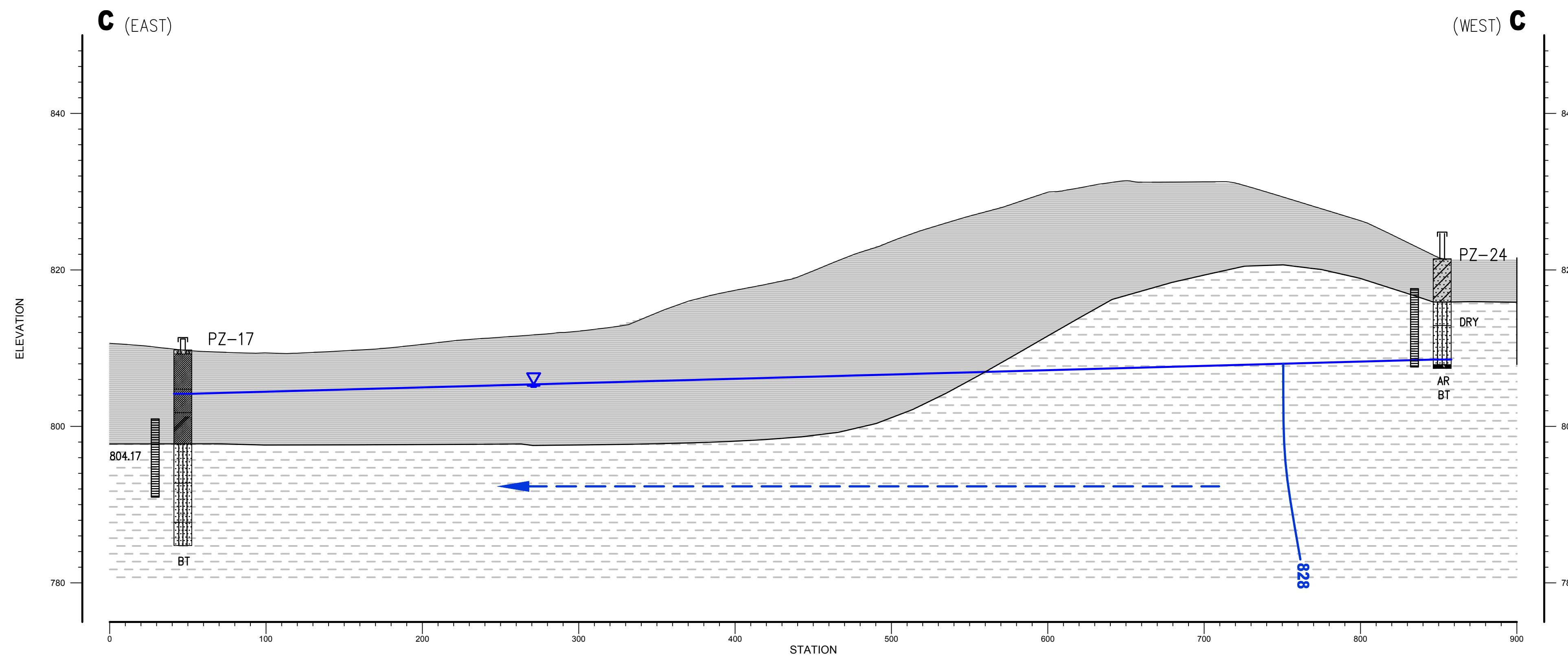

PROFILE LEGEND

- EXISTING TOPOGRAPHY
- GROUNDWATER
- SANDY CLAY
- SAND
- SILTY SAND
- PARTIALLY WEATHERED ROCK
- SANDY SILT
- WATER TABLE SURFACE ON 1-3-19
- CLAY
- 808 EQUIPOTENTIAL LINES (FEET) CONTOUR INTERVAL=4 FEET
- GROUNDWATER FLOW DIRECTION
- HIGH PLASTICITY CLAY
- BT BORING TERMINATED
- CLAYEY SILT
- UPPER RESIDUAL SOIL; CLAYEY SAND, CLAYEY SILT AND SILTY CLAY (SC, ML, CH)
- DEEPER RESIDUAL SOIL, SAND SILT AND SILTY SAND (ML, SM)

HORIZONTAL SCALE: 1"=50'  
VERTICAL SCALE: 1"=10'

SITE LEGEND

- EXISTING TOPOGRAPHY 1'
- 5'
- ACTIVE CROSS SECTION
- INACTIVE CROSS SECTION
- PIEZOMETERS

REFERENCES

- FROM DRAWING TITLED, "PIEZOMETERS AND PIEZOTUBES GREENPOINTE LANDFILL EXPANSION" PROVIDED BY SURVEYORS ENGINEERS AND PLANNERS INC., DATED FEBRUARY 1, 2018

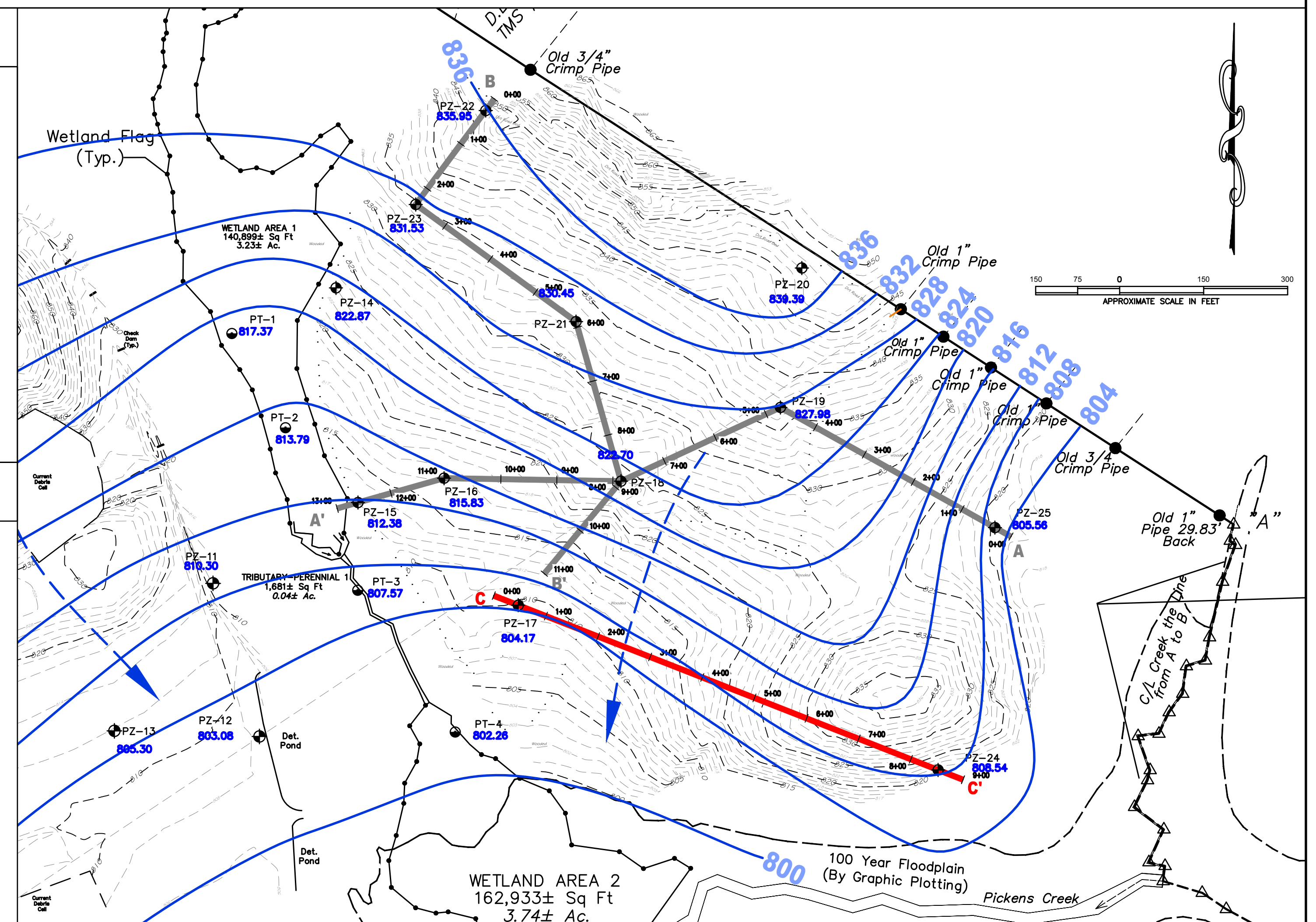

No.	REVISIONS DESCRIPTION	BY

DRAWN: IAI	DATE: 2-26-19
CHECKED: DPO	CAD FILE: GREENPOINTE-02CSLP
APPROVED:	JOB NO: J18-11684-02

**BLE** | **BUNNELL LAMMONS ENGINEERING**  
 6004 Ponders Court, Greenville, SC 29615  
 Phone: (864) 288-1265 Fax: (864) 288-4430

GEOLOGIC PROFILE C-C'  
 GREENPOINTE CLASS II LANDFILL  
 ANDERSON COUNTY, SOUTH CAROLINA

**APPENDIX A**  
**SCDHEC Work Plan Approval Letter**



October 17, 2017

Mr. Radford Jenkins  
Greenpointe, LLC  
PO Box 8028  
Greenville, SC 29604-8028

Re: Workplan for site Hydrogeologic Characterization Study  
Osbourne to Oberly, dated September 20, 2017  
Greenpointe Class 2 Landfill  
Solid Waste Permit #LF2-00001  
Anderson County

Dear Mr. Jenkins:

The referenced document has been reviewed with regards to the requirements of R.61-107.19 Part IV Subpart E of the South Carolina Solid Waste Management Regulations and Solid Waste Permit #LF2-00001.

The workplan to characterize the proposed expansion area is approved. Please find the enclosed well installation permit to install the ten (10) piezometers.

If you have any questions regarding this, please feel free to contact me at (803) 898-1398 or oberlydj@dhec.sc.gov.

Sincerely,

A handwritten signature in blue ink, appearing to read "Dan Oberly", is written over a horizontal line.

David Oberly, II, Hydrogeologist  
Solid Waste Permitting and Monitoring Section  
Division of Mining and Solid Waste Management  
Bureau of Land and Waste Management

Encl. Well installation approval MW-11279

cc: Juli Blalock, Manager, SWPMS  
Bryan Ball, Upstate Region EQC (Anderson)  
Daniel Osbourne, P.G., Bunnell-Lammons Engineering, Inc. dan.osbourne@blecorp.com

Bureau File #21126

## Monitoring Well Approval

**Approval is hereby granted to:** Mr. Radford Jenkins

**Facility:** Greenpointe Class 2 Landfill

**Solid Waste Permit #:** LF2-00001

**County:** Anderson

This approval is for the installation of ten (10) wells. The wells are to be installed in accordance with the September 20, 2017 correspondence and to be constructed within the surficial aquifer for the intended purpose of monitoring groundwater quality and/or water levels at the referenced facility.

**Please note that R.61-71 requires the following:**

1. All wells shall be drilled, constructed, and abandoned by a South Carolina certified well driller per R.61-71.D.1.
2. All wells shall be properly developed per R.61-71.H.2.d. A Water Well Record Form (DHEC 1903) or other form provided or approved by the Department shall be completed for each well and submitted within 30 days after well completion or abandonment unless another schedule has been approved by the Department. The form should contain the "as-built" construction details and all other information required by R.61-71.H.1.f
3. All analytical data and water levels obtained from each monitoring well shall be submitted to the author of this approval within 30 days of receipt of laboratory results unless another schedule has been approved by the Department as required by R.61-71.H.1.d.
4. All monitoring wells shall be labeled as required by R.61-71.H.2.c.
5. If any of the information provided to the Department changes, David Oberly, II (803-898-1398 or OBERLYDJ@dhec.sc.gov) and the regional Solid Waste Inspector Bryan Ball at 864-260-5585 twenty-four (24) hours prior to planned well construction as required by R.61-71.H.1.a.
6. All temporary monitoring wells shall be abandoned within 5 days of borehole completion using appropriate methods as required by R.61-71.H.4.c.

This approval is pursuant to the provisions of Section 44-55-40 of the 1976 South Carolina Code of Laws and R.61-71 of the South Carolina Well Standards and Regulations, dated April 26, 2002.

**Date of Issuance:** September 20, 2017

**Approval #:** MW-11279

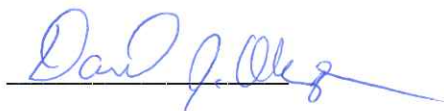

David Oberly, II, Hydrogeologist  
Solid Waste Permitting and Monitoring Section  
Division of Mining and Solid Waste Management  
Bureau of Land and Waste Management



**APPENDIX B**  
**Piezometer Installation Procedures and Boring Logs**

# KEY TO SOIL CLASSIFICATIONS AND CONSISTENCY DESCRIPTIONS

BUNNELL-LAMMONS ENGINEERING, INC.  
GREENVILLE, SOUTH CAROLINA

## Penetration Resistance\* Blows per Foot

SANDS  
0 to 4  
5 to 10  
11 to 20  
21 to 30  
31 to 50  
over 50

## Relative Density

Very Loose  
Loose  
Firm  
Very Firm  
Dense  
Very Dense

## Particle Size Identification

Boulder: Greater than 300 mm  
Cobble: 75 to 300 mm  
Gravel:  
Coarse - 19 to 75 mm  
Fine - 4.75 to 19 mm  
Sand:  
Coarse - 2 to 4.75 mm  
Medium - 0.425 to 2 mm  
Fine - 0.075 to 0.425 mm  
Silt & Clay: Less than 0.075 mm

## Penetration Resistance\* Blows per Foot

SILTS and CLAYS  
0 to 2  
3 to 4  
5 to 8  
9 to 15  
16 to 30  
31 to 50  
over 50

## Consistency

Very Soft  
Soft  
Firm  
Stiff  
Very Stiff  
Hard  
Very Hard

\*ASTM D 1586

## KEY TO DRILLING SYMBOLS



Grab Sample



Split Spoon Sample



Undisturbed Sample

NR = No reaction to HCL

NA = Not applicable

NS = No sample



Groundwater Table at Time of Drilling



Groundwater Table 24 Hours after Completion of Drilling

## KEY TO SOIL CLASSIFICATIONS



Well-graded Gravel  
GW

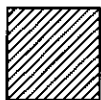

Low Plasticity Clay  
CL

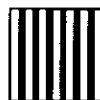

Clayey Silt  
MH

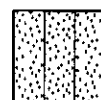

Silty Sand  
SM



Poorly-graded Gravel  
GP

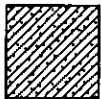

Sandy Clay  
CLS

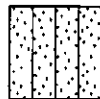

Sandy Silt  
MLS



Topsoil  
TOPSOIL



Partially Weathered Rock  
BLDRCBBL

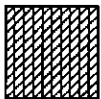

Silty Clay  
CL-ML

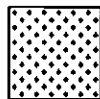

Sand  
SW

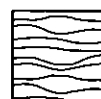

Liquid Sludge  
SLUDGE

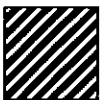

High Plasticity Clay  
CH

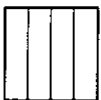

Silt  
ML

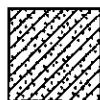

Clayey Sand  
SC

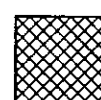

Fill  
FILL

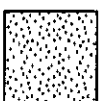

Poorly Graded Sand  
SP

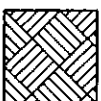

Bedrock  
BEDROCK

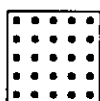

Waste  
WOOD



**BUNNELL-LAMMONS  
ENGINEERING, INC.**  
GEOTECHNICAL AND ENVIRONMENTAL  
CONSULTANTS

**GROUNDWATER MONITORING WELL NO. PZ-14**

PROJECT: Greenpointe Class 2 Landfill

PROJECT NO.: J17-11684-02

CLIENT: Greenpointe Landfill, LLC

START: 12-4-17 END: 12-4-17

LOCATION: Easley, South Carolina

ELEVATION: 822.99

DRILLER: Landprobe, R. Banks

LOGGED BY: R. Doherty

DRILLING METHOD: CME 750; 4-1/4 inch hollow stem auger

DEPTH TO - WATER> INITIAL:  $\nabla$  1.5 AFTER 24 HOURS:  $\nabla$  1.5 CAVING:  $\otimes$

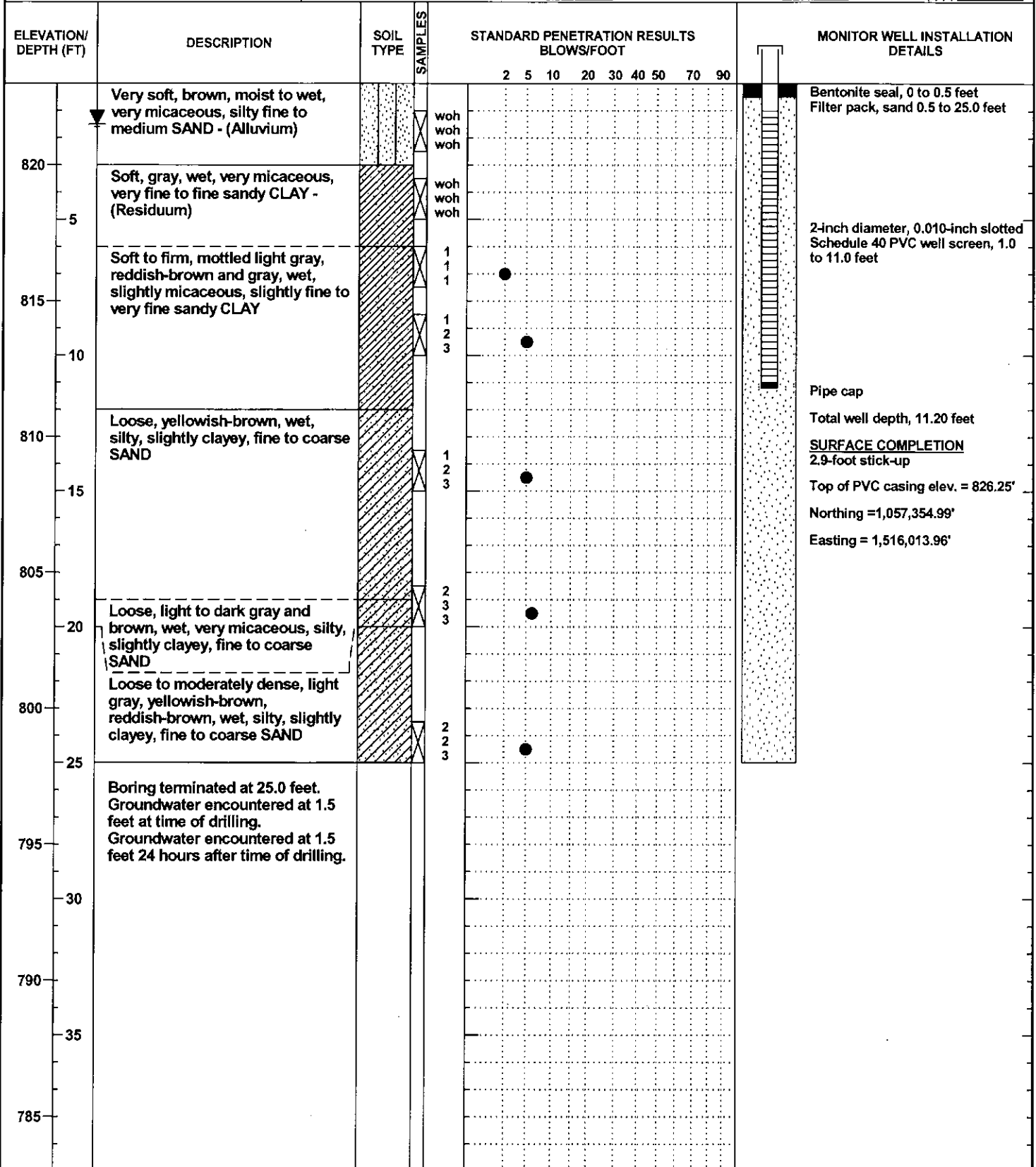



**BUNNELL-LAMMONS  
ENGINEERING, INC.**  
GEOTECHNICAL AND ENVIRONMENTAL  
CONSULTANTS

**GROUNDWATER MONITORING WELL NO. PZ-15**

PROJECT: Greenpointe Class 2 Landfill

PROJECT NO.: J17-11684-02

CLIENT: Greenpointe Landfill, LLC

START: 12-5-17 END: 12-5-17

LOCATION: Easley, South Carolina

ELEVATION: 813.03

DRILLER: Landprobe, R. Banks

LOGGED BY: R. Doherty

DRILLING METHOD: CME 750; 4-1/4 inch hollow stem auger

DEPTH TO - WATER> INITIAL: ▽ 2.7 AFTER 24 HOURS: ▽ 2.11 CAVING: ▨

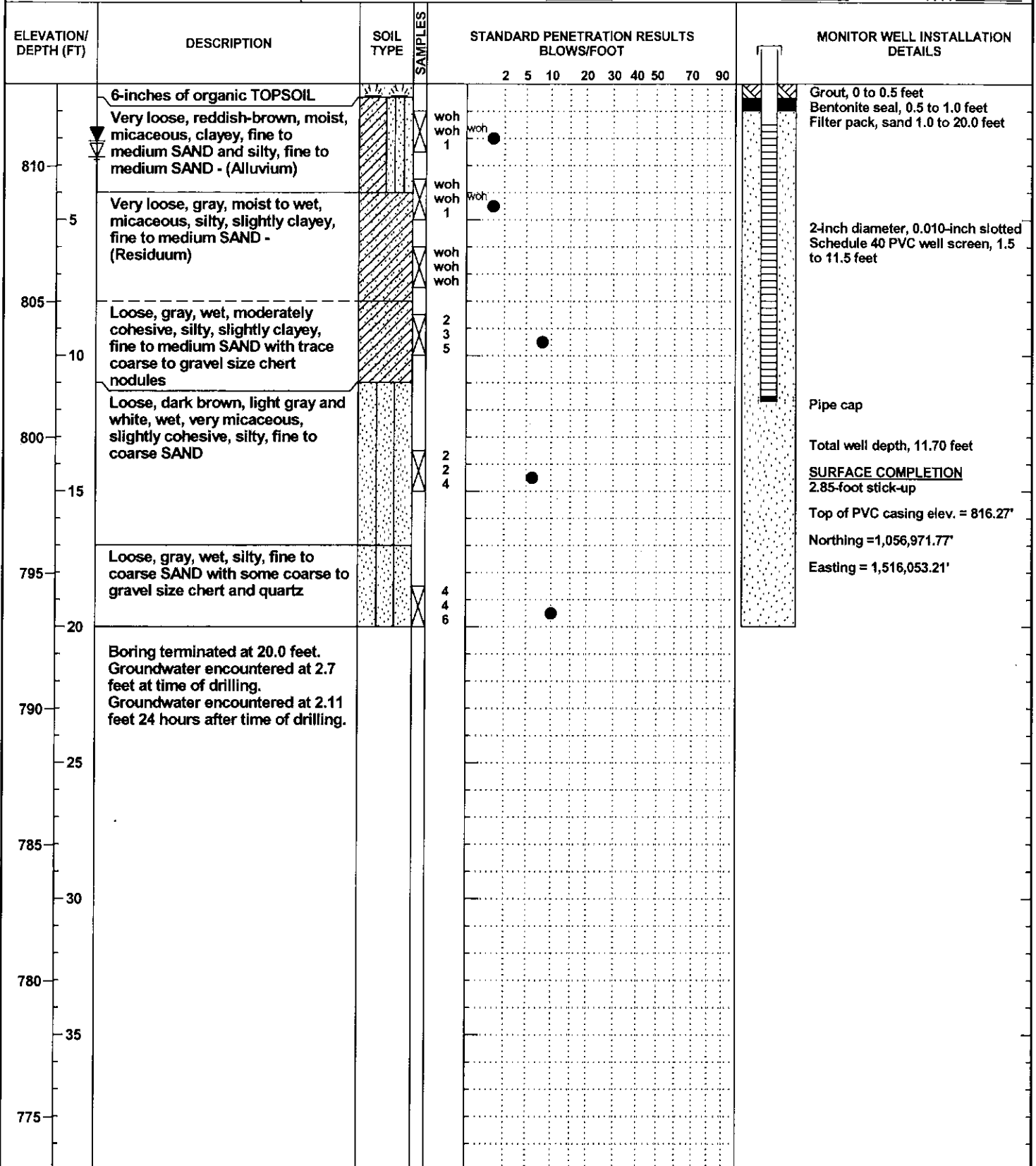



**BUNNELL-LAMMONS  
ENGINEERING, INC.**  
GEOTECHNICAL AND ENVIRONMENTAL  
CONSULTANTS

### GROUNDWATER MONITORING WELL NO. PZ-16

PROJECT: Greenpointe Class 2 Landfill

PROJECT NO.: J17-11684-02

CLIENT: Greenpointe Landfill, LLC

START: 12-5-17 END: 12-5-17

LOCATION: Easley, South Carolina

ELEVATION: 816.24

DRILLER: Landprobe, R. Banks

LOGGED BY: R. Doherty

DRILLING METHOD: CME 750; 4-1/4 inch hollow stem auger

DEPTH TO - WATER> INITIAL:  $\nabla$  8.2 AFTER 24 HOURS:  $\nabla$  1.5 CAVING:

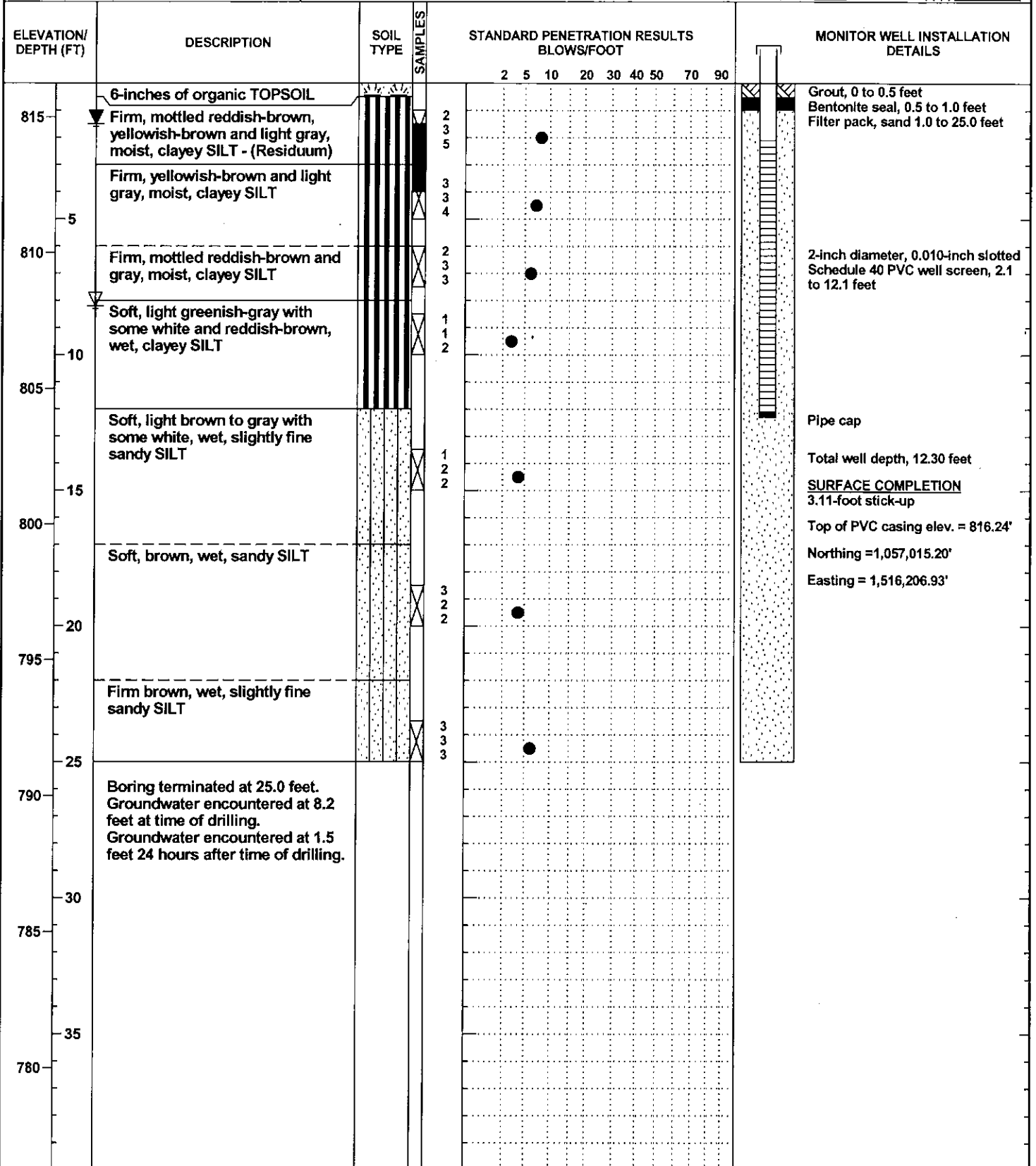



**BUNNELL-LAMMONS  
ENGINEERING, INC.**  
GEOTECHNICAL AND ENVIRONMENTAL  
CONSULTANTS

**GROUNDWATER MONITORING WELL NO. PZ-17**

PROJECT: Greenpointe Class 2 Landfill PROJECT NO.: J17-11684-02  
 CLIENT: Greenpointe Landfill, LLC START: 12-5-17 END: 12-5-17  
 LOCATION: Easley, South Carolina ELEVATION: 809.76  
 DRILLER: Landprobe, R. Banks LOGGED BY: R. Doherty  
 DRILLING METHOD: CME 750; 4-1/4 inch hollow stem auger  
 DEPTH TO - WATER> INITIAL: ▽ 10.14 AFTER 24 HOURS: ▼ 8.0 CAVING > ⊗

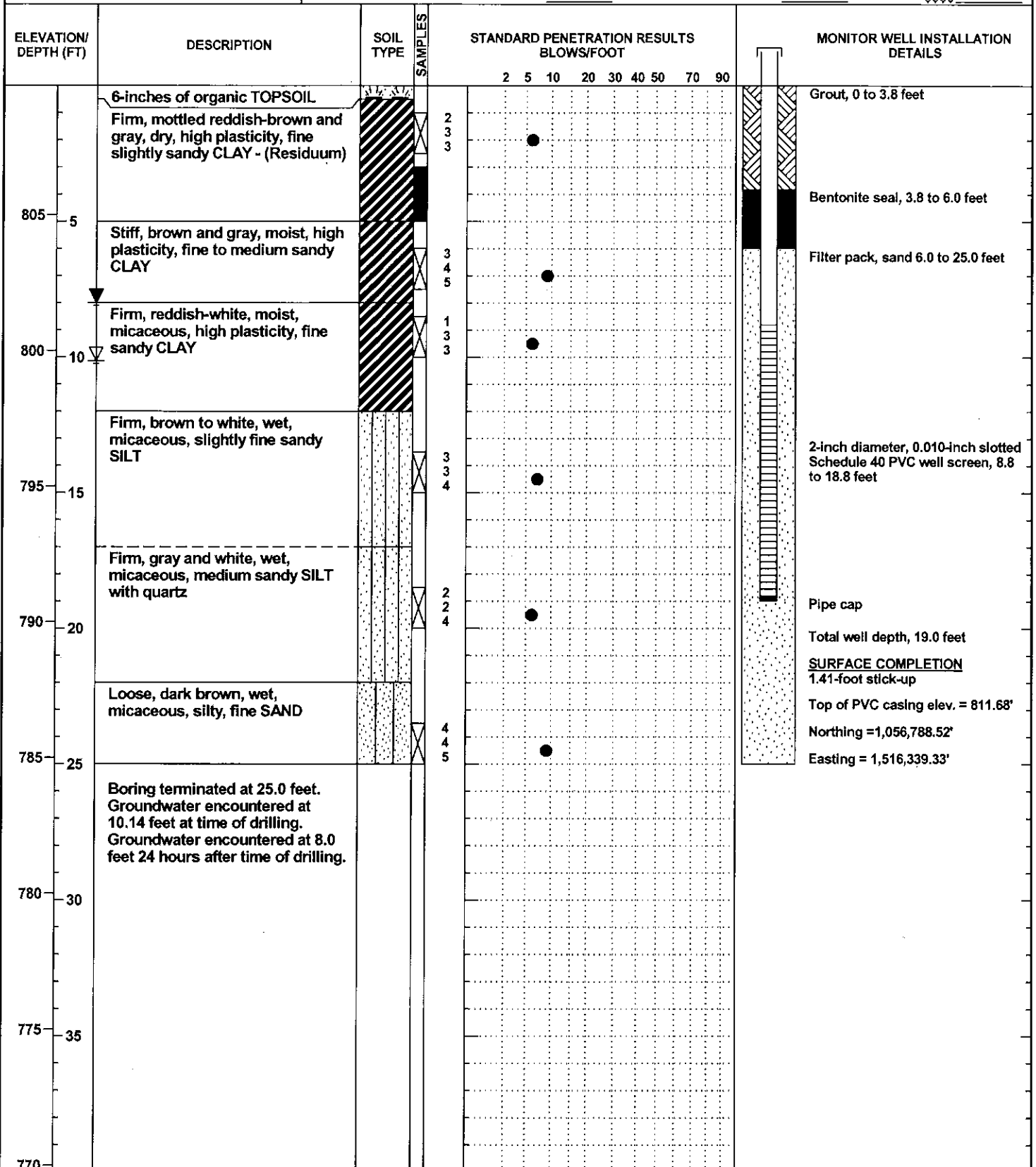

GEOT. WELL 11684-02.GPJ 5/14/19



**BUNNELL-LAMMONS  
ENGINEERING, INC.**  
GEOTECHNICAL AND ENVIRONMENTAL  
CONSULTANTS

**GROUNDWATER MONITORING WELL NO. PZ-18**

PROJECT: Greenpointe Class 2 Landfill

PROJECT NO.: J17-11684-02

CLIENT: Greenpointe Landfill, LLC

START: 12-5-17 END: 12-5-17

LOCATION: Easley, South Carolina

ELEVATION: 824.02

DRILLER: Landprobe, R. Banks

LOGGED BY: R. Doherty

DRILLING METHOD: CME 750; 4-1/4 inch hollow stem auger

DEPTH TO - WATER> INITIAL: ▽ 10.2 AFTER 24 HOURS: ▽ 5.8 CAVING> ☒

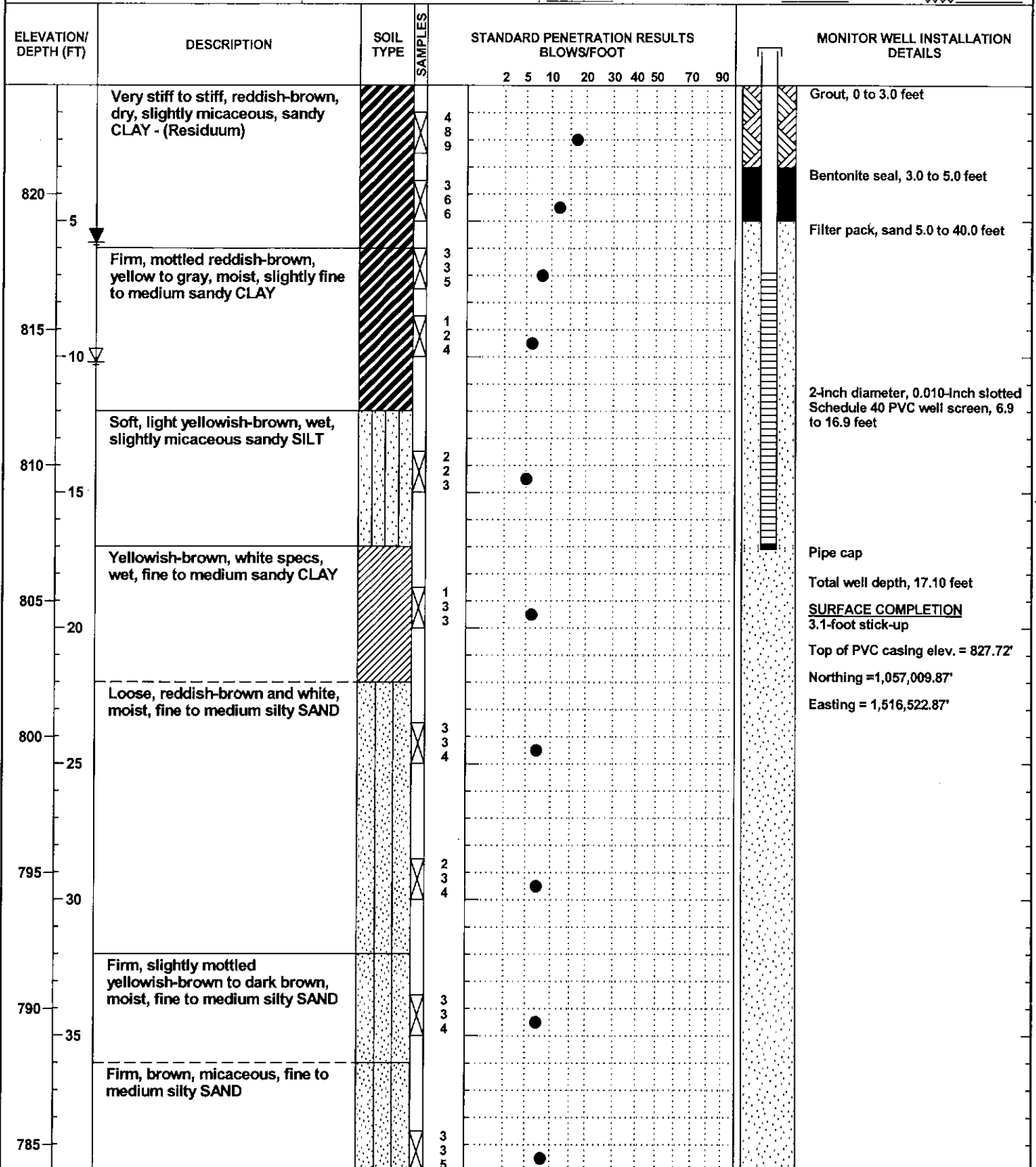

GROUNDWATER MONITORING WELL NO. PZ-18

Sheet 1 of 2

GEOT. WELL 11684-02.GPJ 5/14/19



**BUNNELL-LAMMONS  
ENGINEERING, INC.**  
GEOTECHNICAL AND ENVIRONMENTAL  
CONSULTANTS

**GROUNDWATER MONITORING WELL NO. PZ-18**

PROJECT: Greenpointe Class 2 Landfill PROJECT NO.: J17-11684-02  
 CLIENT: Greenpointe Landfill, LLC START: 12-5-17 END: 12-5-17  
 LOCATION: Easley, South Carolina ELEVATION: 824.02  
 DRILLER: Landprobe, R. Banks LOGGED BY: R. Doherty  
 DRILLING METHOD: CME 750; 4-1/4 inch hollow stem auger  
 DEPTH TO - WATER> INITIAL: ∇ 10.2 AFTER 24 HOURS: ∇ 5.8 CAVING> ☒

ELEVATION/ DEPTH (FT)	DESCRIPTION	SOIL TYPE	SAMPLES	STANDARD PENETRATION RESULTS BLOWS/FOOT								MONITOR WELL INSTALLATION DETAILS									
				2	5	10	20	30	40	50	70		90								
780	Boring terminated at 40.0 feet. Groundwater encountered at 10.2 feet at time of drilling. Groundwater encountered at 5.8 feet 24 hours after time of drilling.																				
775																					
770																					
765																					
760																					
755																					
750																					
745																					

GEOI WELL 11684-02.GPJ 5/14/19





**BUNNELL-LAMMONS  
ENGINEERING, INC.**  
GEOTECHNICAL AND ENVIRONMENTAL  
CONSULTANTS

**GROUNDWATER MONITORING WELL NO. PZ-19**

PROJECT: Greenpointe Class 2 Landfill

PROJECT NO.: J17-11684-02

CLIENT: Greenpointe Landfill, LLC

START: 12-6-17 END: 12-6-17

LOCATION: Easley, South Carolina

ELEVATION: 837.05

DRILLER: Landprobe, R. Banks

LOGGED BY: R. Doherty

DRILLING METHOD: CME 750; 4-1/4 inch hollow stem auger

DEPTH TO - WATER> INITIAL:  $\nabla$  15.25 AFTER 24 HOURS:  $\nabla$  28.16 CAVING:  $\otimes$

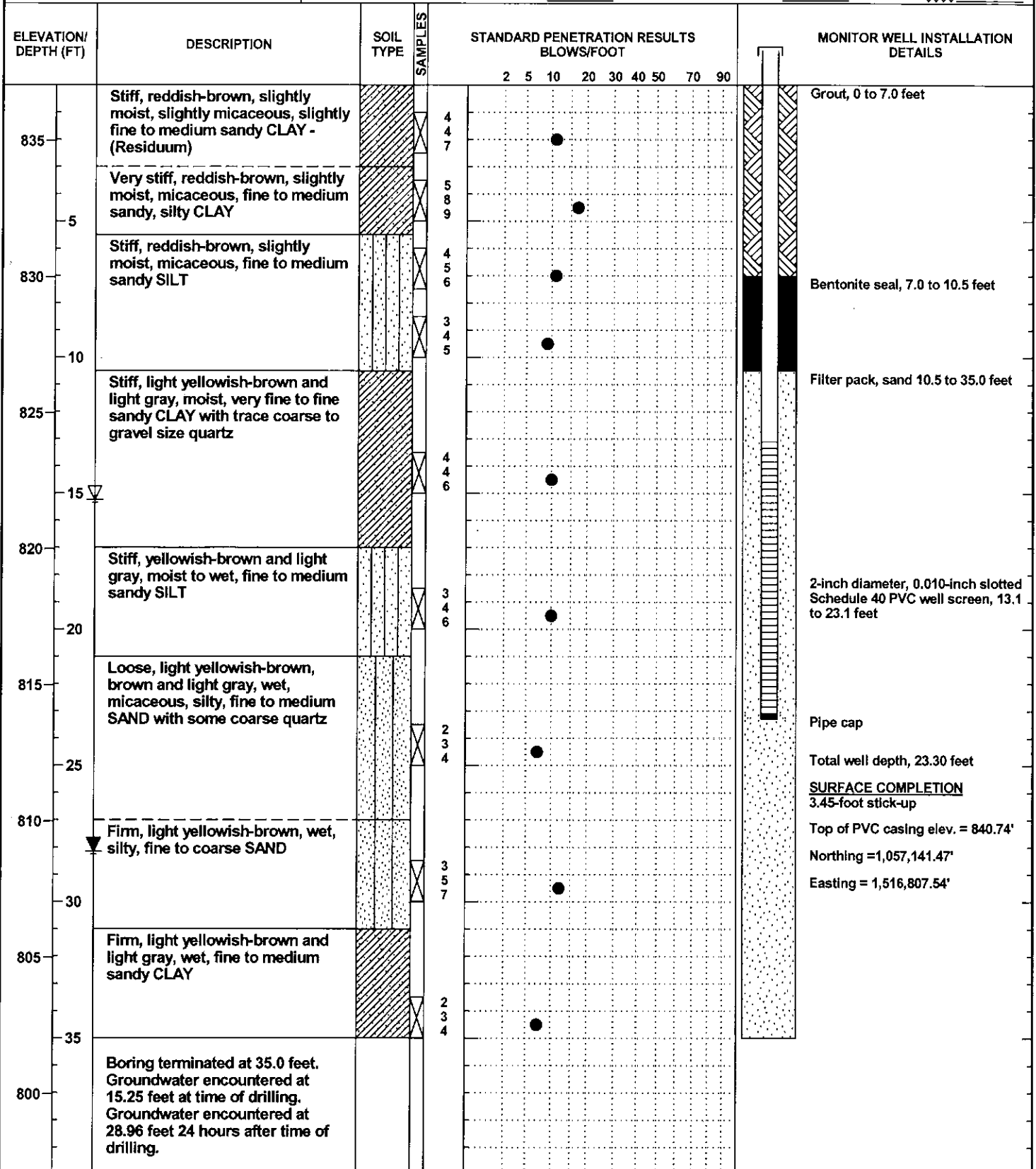

GEO. WELL 11684-02.GPJ 5/14/19



**BUNNELL-LAMMONS  
ENGINEERING, INC.**  
GEOTECHNICAL AND ENVIRONMENTAL  
CONSULTANTS

**GROUNDWATER MONITORING WELL NO. PZ-20**

PROJECT: Greenpointe Class 2 Landfill

PROJECT NO.: J17-11684-02

CLIENT: Greenpointe Landfill, LLC

START: 12-6-17 END: 12-18-17

LOCATION: Easley, South Carolina

ELEVATION: 847.19

DRILLER: Landprobe, R. Banks

LOGGED BY: R. Doherty

DRILLING METHOD: CME 750; 4-1/4 inch hollow stem auger

DEPTH TO - WATER> INITIAL:  $\nabla$  17.70 AFTER 24 HOURS:  $\nabla$  20.11 CAVING:

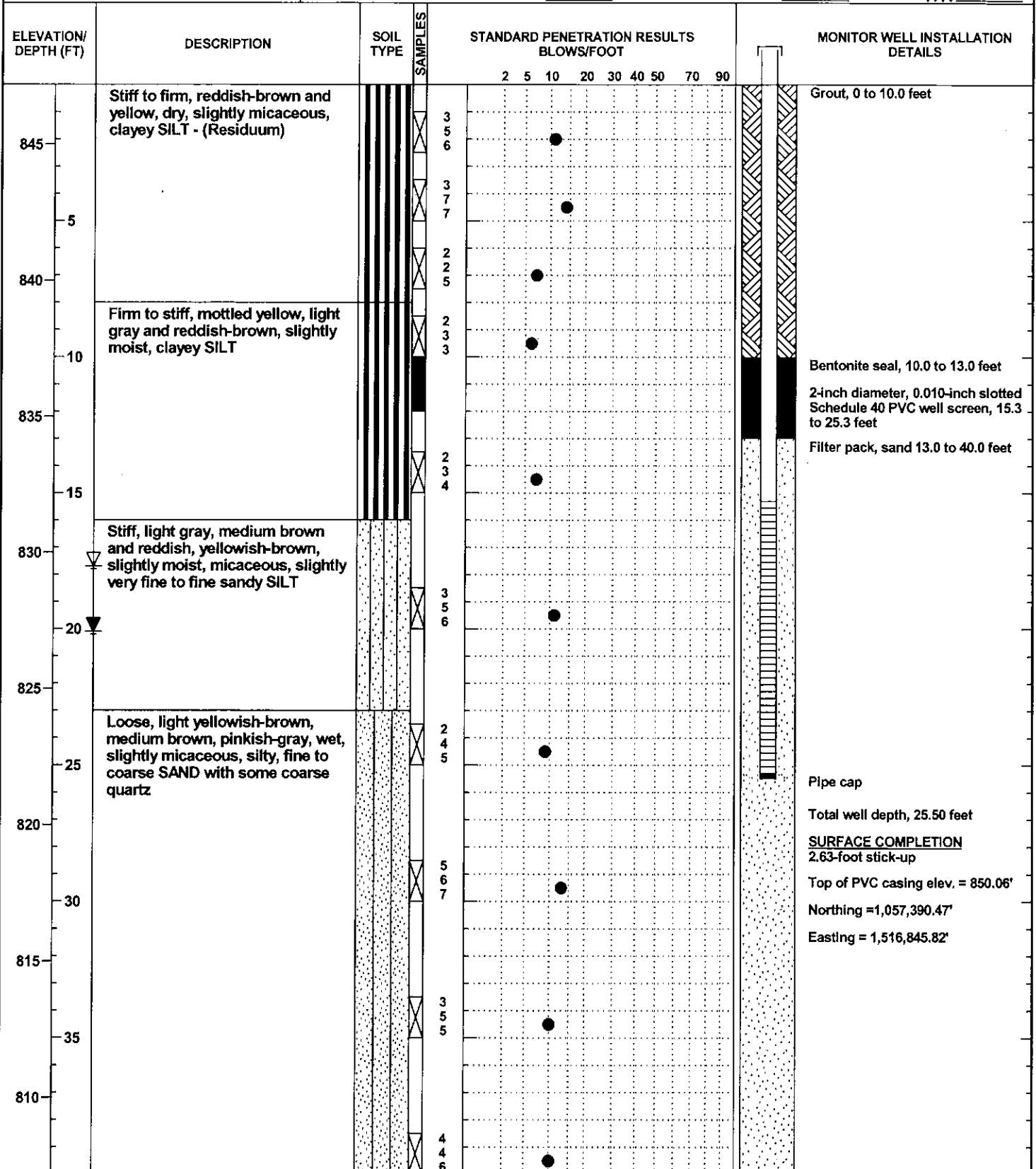

GEOI\_WELL\_11684-02.GPJ 5/14/19



**BUNNELL-LAMMONS  
ENGINEERING, INC.**  
GEOTECHNICAL AND ENVIRONMENTAL  
CONSULTANTS

**GROUNDWATER MONITORING WELL NO. PZ-20**

PROJECT: Greenpointe Class 2 Landfill  
 CLIENT: Greenpointe Landfill, LLC  
 LOCATION: Easley, South Carolina  
 DRILLER: Landprobe, R. Banks  
 DRILLING METHOD: CME 750; 4-1/4 inch hollow stem auger  
 DEPTH TO - WATER> INITIAL:  $\nabla$  17.70 AFTER 24 HOURS:  $\nabla$  20.11 CAVING>  $\otimes$

PROJECT NO.: J17-11684-02  
 START: 12-6-17 END: 12-18-17  
 ELEVATION: 847.19  
 LOGGED BY: R. Doherty

ELEVATION/ DEPTH (FT)	DESCRIPTION	SOIL TYPE	SAMPLES	STANDARD PENETRATION RESULTS BLOWS/FOOT								MONITOR WELL INSTALLATION DETAILS			
				2	5	10	20	30	40	50	70		90		
805	Boring terminated at 40.0 feet. Groundwater encountered at 17.70 feet at time of drilling. Groundwater encountered at 20.11 feet 24 hours after time of drilling.														
800															
795															
790															
785															
780															
775															
770															
765															
760															
755															
750															
745															
740															
735															
730															
725															
720															
715															
710															

GEOT WELL 11684-02.GPJ 5/14/19



**BUNNELL-LAMMONS  
ENGINEERING, INC.**  
GEOTECHNICAL AND ENVIRONMENTAL  
CONSULTANTS

**GROUNDWATER MONITORING WELL NO. PZ-21**

PROJECT: Greenpointe Class 2 Landfill

PROJECT NO.: J17-11684-02

CLIENT: Greenpointe Landfill, LLC

START: 12-18-17 END: 12-18-17

LOCATION: Easley, South Carolina

ELEVATION: 833.02

DRILLER: Landprobe, R. Banks

LOGGED BY: R. Doherty

DRILLING METHOD: CME 750; 4-1/4 inch hollow stem auger

DEPTH TO - WATER> INITIAL:  $\nabla$  5.7 AFTER 24 HOURS:  $\nabla$  7.42 CAVING:

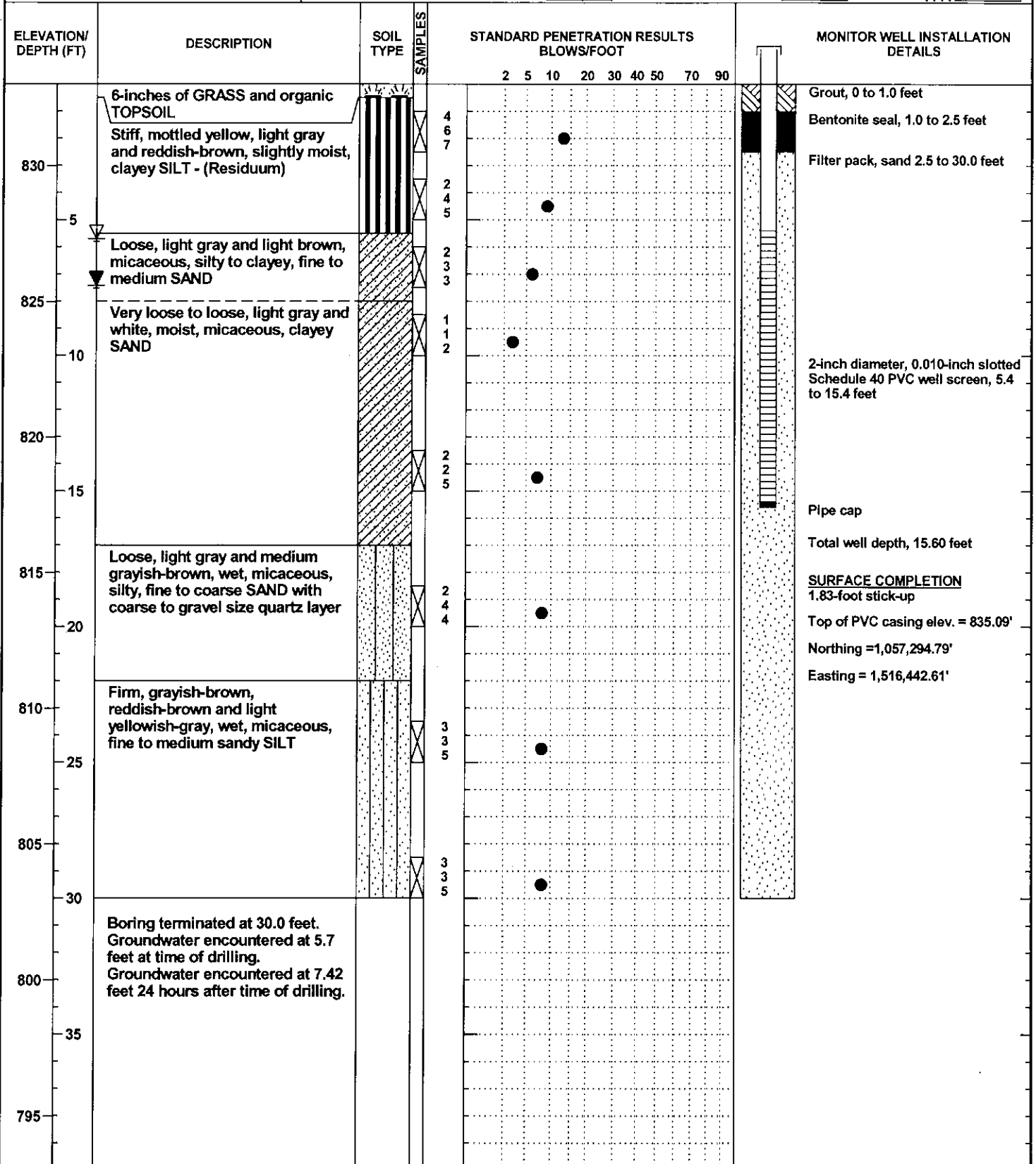

GEO. WELL 11684-02.GPJ 5/14/19



**BUNNELL-LAMMONS  
ENGINEERING, INC.**  
GEOTECHNICAL AND ENVIRONMENTAL  
CONSULTANTS

## GROUNDWATER MONITORING WELL NO. PZ-22

PROJECT: <u>Greenpointe Class 2 Landfill</u>	PROJECT NO.: <u>J17-11684-02</u>
CLIENT: <u>Greenpointe Landfill, LLC</u>	START: <u>12-18-17</u> END: <u>12-18-17</u>
LOCATION: <u>Easley, South Carolina</u>	ELEVATION: <u>846.99</u>
DRILLER: <u>Landprobe, R. Banks</u>	LOGGED BY: <u>R. Doherty</u>
DRILLING METHOD: <u>CME 750; 4-1/4 inch hollow stem auger</u>	
DEPTH TO - WATER> INITIAL: ▽ 13.88 AFTER 24 HOURS: ▽ 16.69 CAVING> ☒	

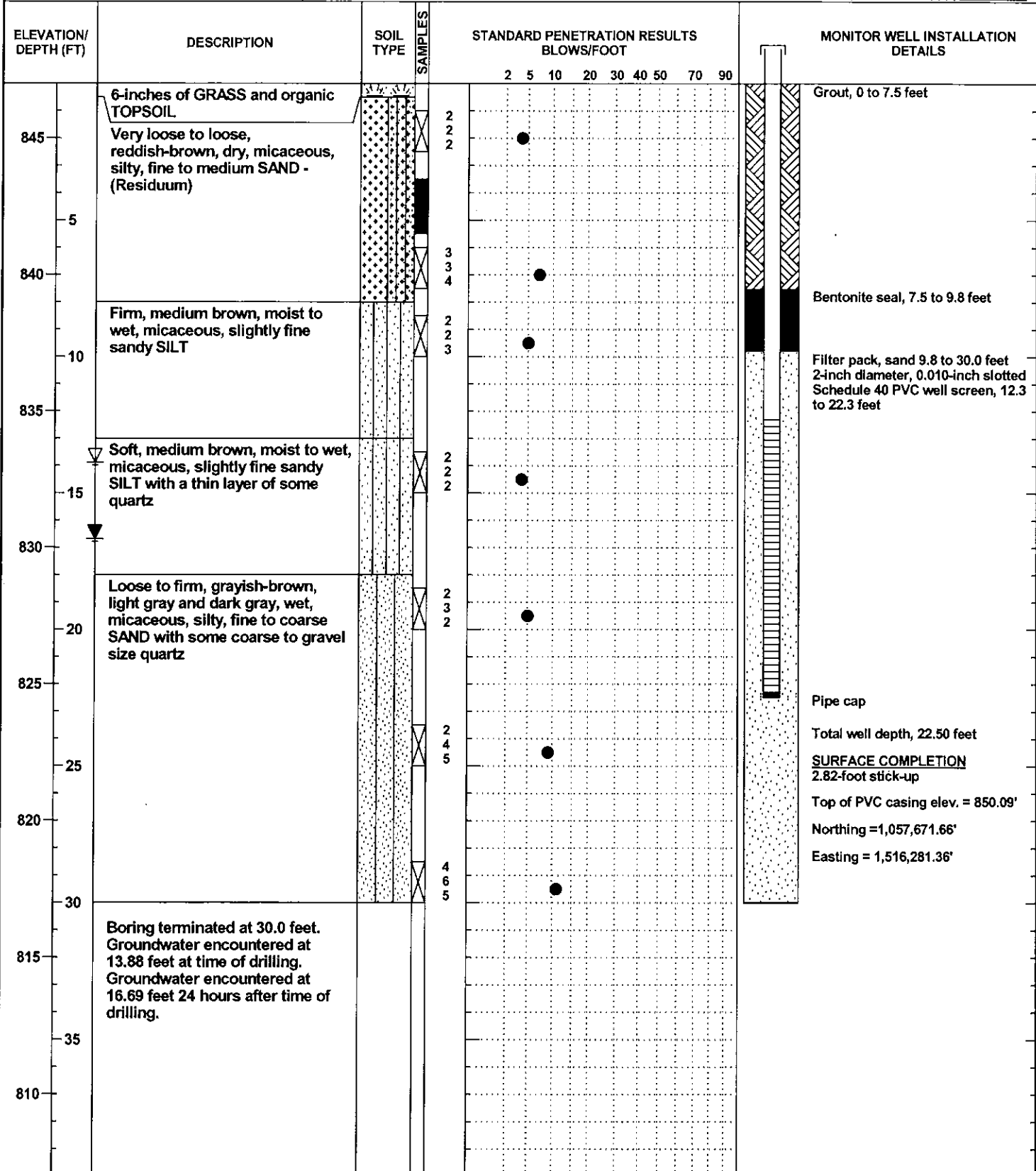

GEOT\_WELL\_11684-02.GPJ\_5/14/19



**BUNNELL-LAMMONS  
ENGINEERING, INC.**  
GEOTECHNICAL AND ENVIRONMENTAL  
CONSULTANTS

**GROUNDWATER MONITORING WELL NO. PZ-23**

PROJECT: Greenpointe Class 2 Landfill

PROJECT NO.: J17-11684-02

CLIENT: Greenpointe Landfill, LLC

START: 12-19-17 END: 12-19-17

LOCATION: Easley, South Carolina

ELEVATION: 834.58

DRILLER: Landprobe, R. Banks

LOGGED BY: R. Doherty

DRILLING METHOD: CME 750; 4-1/4 inch hollow stem auger

DEPTH TO - WATER> INITIAL:  $\nabla$  4.82 AFTER 24 HOURS:  $\nabla$  9.0 CAVING:  $\otimes$

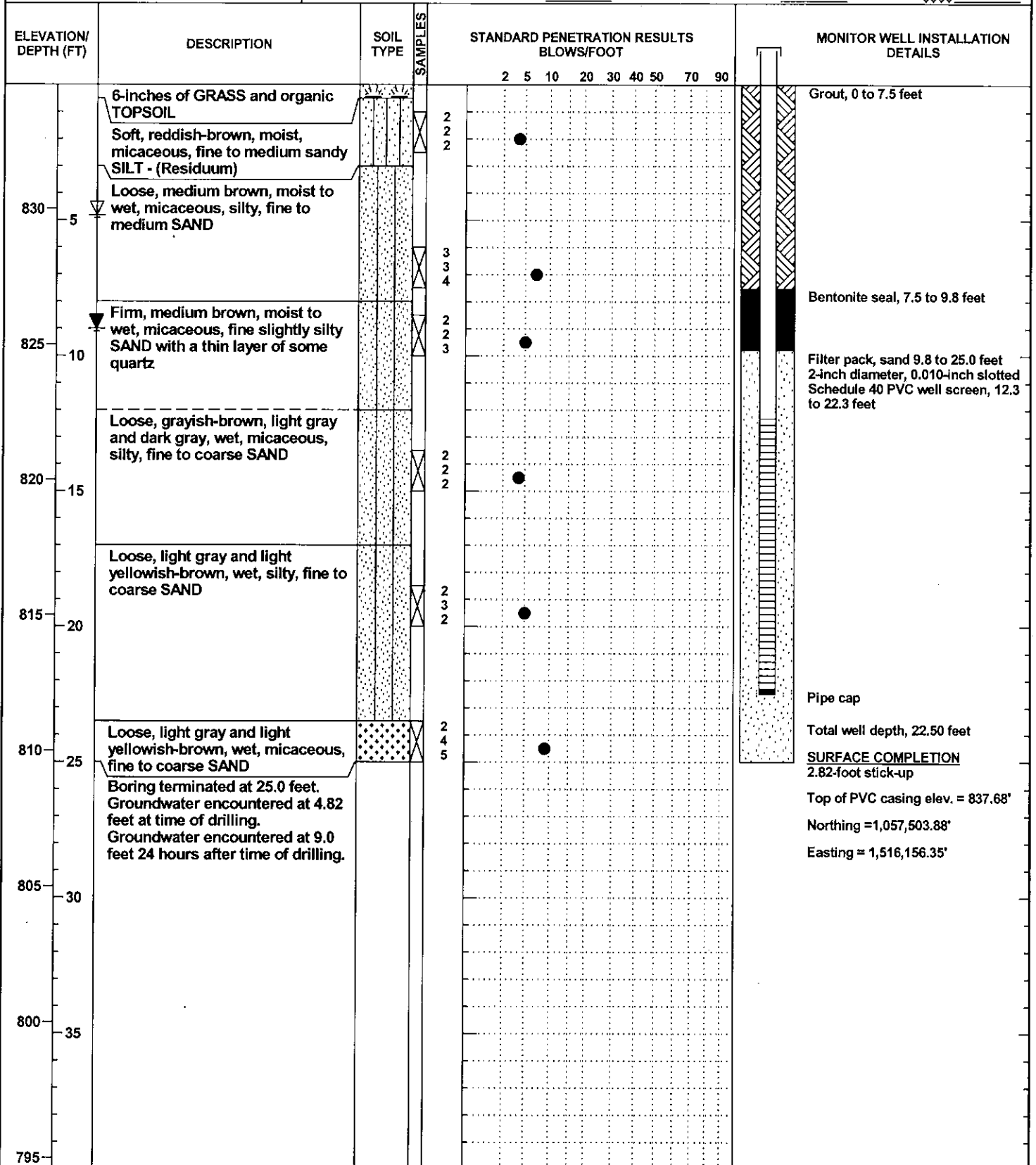

GEOI\_WELL\_11684-02.GPJ 5/14/19



**BUNNELL-LAMMONS  
ENGINEERING, INC.**  
GEOTECHNICAL AND ENVIRONMENTAL  
CONSULTANTS

### GROUNDWATER MONITORING WELL NO. PZ-24

PROJECT: Greenpointe Class 2 Landfill

PROJECT NO.: J17-11684-02

CLIENT: Greenpointe Landfill, LLC

START: 3-22-18 END: 3-23-18

LOCATION: Easley, South Carolina

ELEVATION: 821.40

DRILLER: Landprobe, S. Dyer

LOGGED BY: B.P. Davis

DRILLING METHOD: CME 750; 4-1/4 inch hollow stem auger

DEPTH TO - WATER> INITIAL: ▽ 13.11 AFTER 24 HOURS: ▽ 13.13 CAVING> ☒

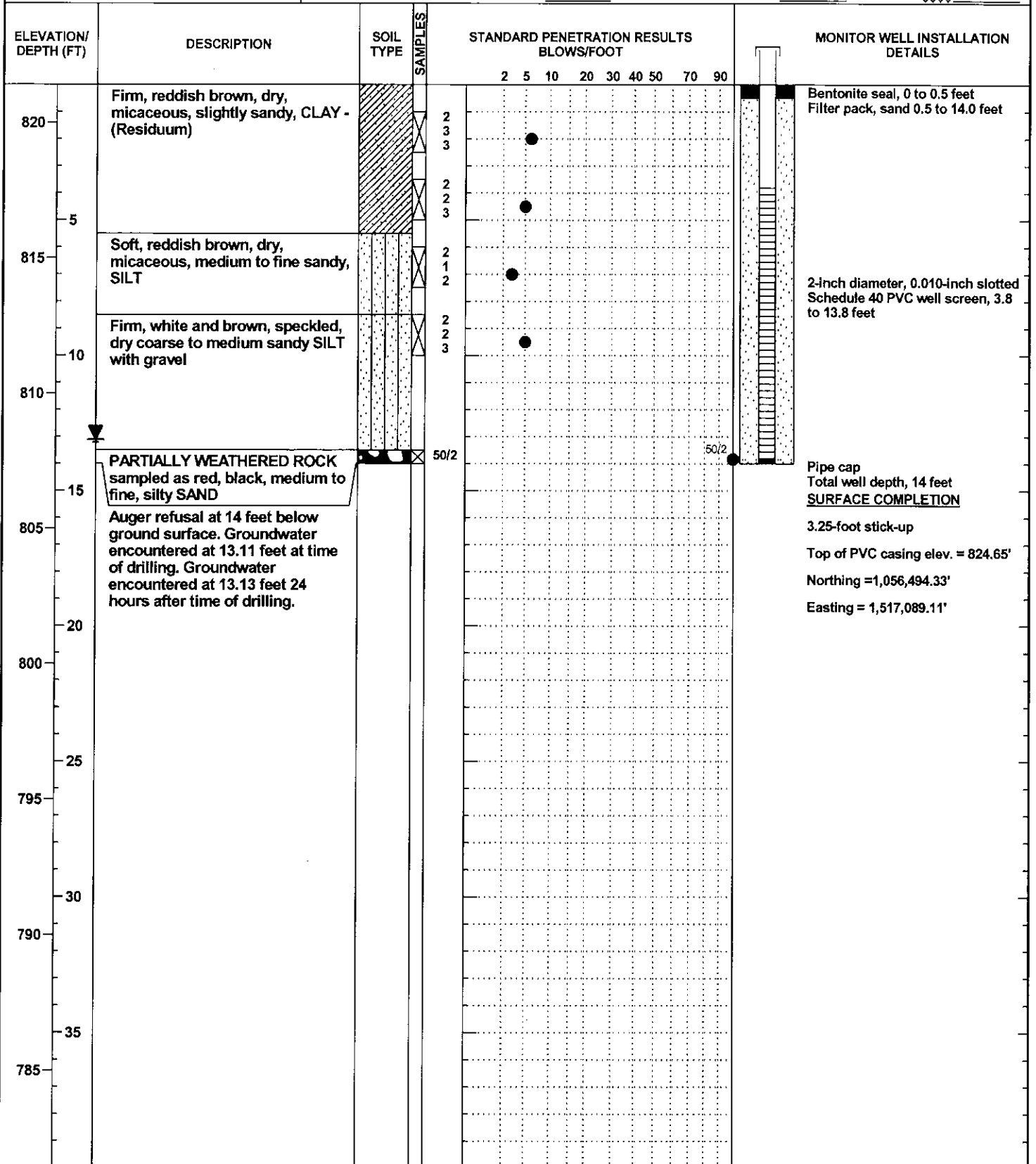

GEOI WELL\_11684-02.GPJ 5/14/19



**BUNNELL-LAMMONS  
ENGINEERING, INC.**  
GEOTECHNICAL AND ENVIRONMENTAL  
CONSULTANTS

**GROUNDWATER MONITORING WELL NO. PZ-25**

PROJECT: Greenpointe Class 2 Landfill  
 CLIENT: Greenpointe Landfill, LLC  
 LOCATION: Easley, South Carolina  
 DRILLER: Landprobe, S. Dyer  
 DRILLING METHOD: CME 750; 4-1/4 inch hollow stem auger  
 DEPTH TO - WATER> INITIAL: 16.2 AFTER 24 HOURS: 18.87 CAVING: X

PROJECT NO.: J17-11684-02  
 START: 3-23-18 END: 3-23-18  
 ELEVATION: 819.71  
 LOGGED BY: M. Parks

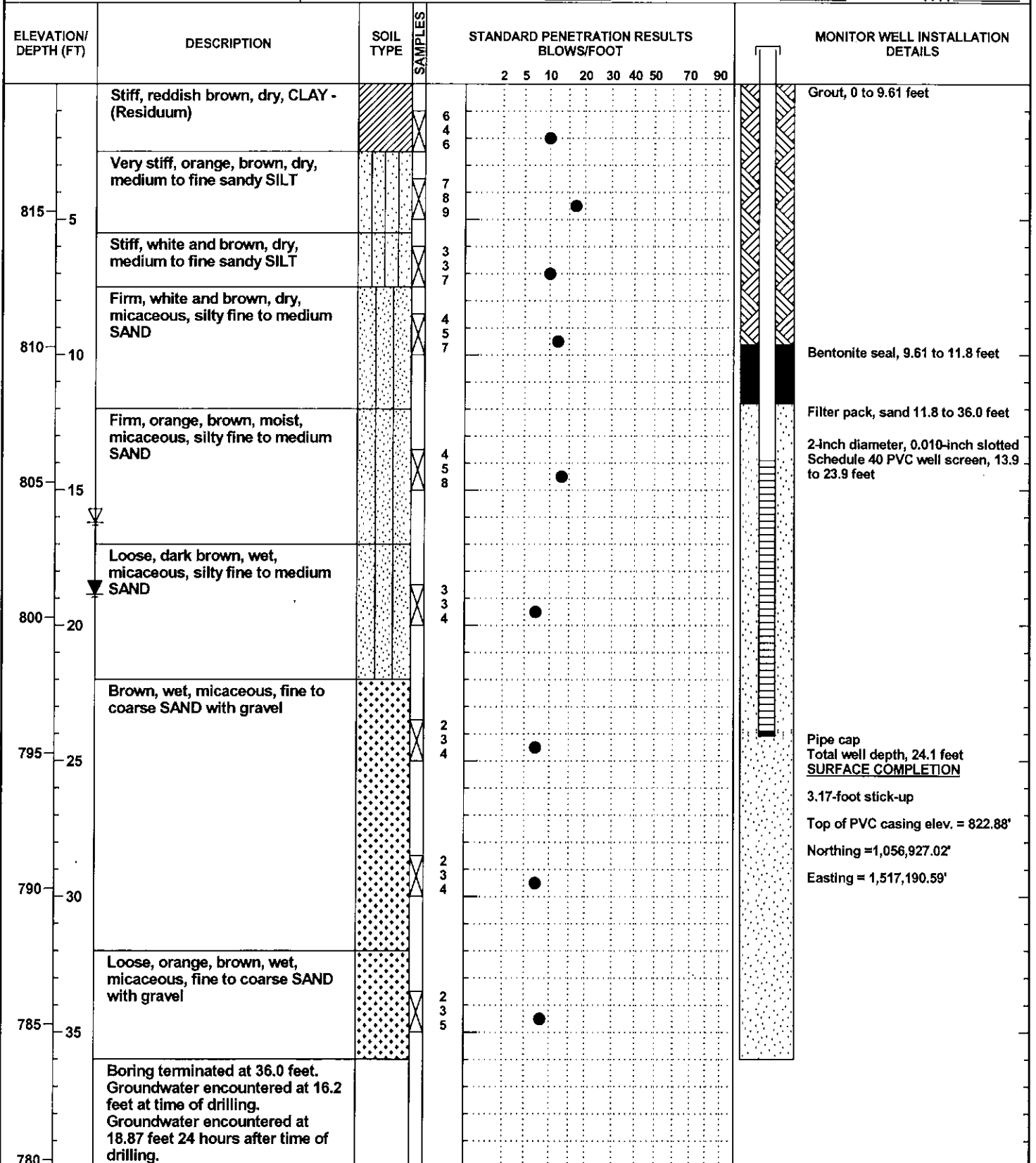

GEOT\_WELL\_11684-02.GPJ 5/14/19



**APPENDIX C**  
**Slug Test Procedures and Data**

## APPENDIX C

### SLUG TEST PROCEDURES AND RESULTS

Slug tests were performed in the field to estimate the average hydraulic conductivity of the formation materials. Hydraulic conductivity is a constant of proportionality relating to the ease with which a fluid passes through a porous medium. These data were used to estimate the groundwater flow velocities of groundwater beneath the site. The field procedure was as follows:

- Measure the static groundwater elevation in the well to be tested.
- Affect an instantaneous change to the static water level in the well by removing a known volume of water.
- Measure the rate at which the water level recovers to its original level (see attachments).

The resulting slug test data (time versus water level) was reduced and hydraulic conductivity values were calculated using the Bouwer and Rice Method for partially penetrating wells in unconfined aquifers.

# Falling Head Slug Test 1/24/18

Greenpointe Landfill Anderson, SC

# Bouwer and Rice Graph

PZ-15

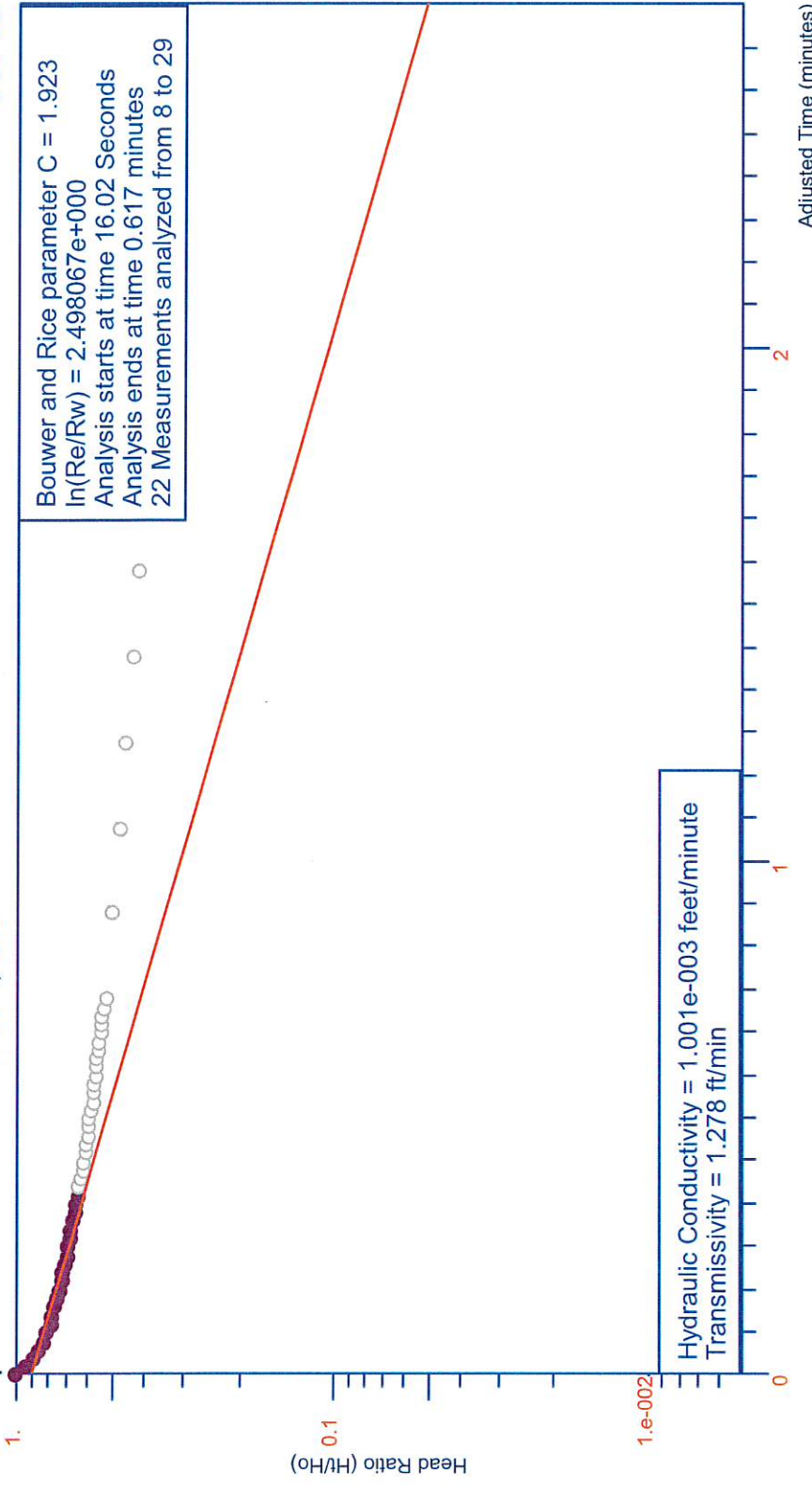

Project Number: 11684-02 for Greenpointe Landfill  
Analysis by Starpoint Software

Ho is 0.1786 Meters at 16.02 Seconds

**Falling Head Slug Test**

Site Name: Greenpointe Landfill  
 Location: Anderson, SC  
 Test Date: 1/24/18  
 Client: Greenpointe Landfill  
 Project Number: 11684-02  
 Import File: \\blegvlsvr1\SolidWasteProjects\Greenpointe LF, Anderson, SC\11684-02 Site Hydr

---

Well Label: PZ-15  
 Aquifer Thickness: 2.908 Meters  
 Screen Length: 2.908 Meters  
 Casing Radius: 2.54e-002 Meters  
 Effective Radius: 0.1048 Meters  
 Static Water Level: 0. Meters  
 Water Table to Screen Bottom: 2.908 Meters  
 Anisotropy Ratio: 2.  
 Time Adjustment: 16.02 Seconds

Test starts with trial 0

There are 62 time and drawdown measurements

Maximum head is 0.5803 Meters

Minimum head is 0. Meters

---

Trial	Time (minutes)	Adjusted Time (minutes)	Drawdown (Meters)	Head (Meters)	Head Ratio
1	0.15	-0.117	0.5803	0.5803	1.
2	0.167	-0.1	0.3264	0.3264	0.5625
3	0.183	-8.4e-002	0.3371	0.3371	0.5809
4	0.2	-6.7e-002	0.2838	0.2838	0.489
5	0.217	-5.e-002	0.2521	0.2521	0.4343
6	0.233	-3.4e-002	0.2246	0.2246	0.3871
7	0.25	-1.7e-002	0.1963	0.1963	0.3382
8	0.267	0.	0.1786	0.1786	0.3078
9	0.283	1.6e-002	0.1667	0.1667	0.2873
10	0.3	3.3e-002	0.1585	0.1585	0.2731
11	0.317	5.e-002	0.1527	0.1527	0.2631
12	0.333	6.6e-002	0.1469	0.1469	0.2532
13	0.35	8.3e-002	0.1433	0.1433	0.2468
14	0.367	1.e-001	0.1396	0.1396	0.2405
15	0.383	0.116	0.1375	0.1375	0.2369
16	0.4	0.133	0.135	0.135	0.2327
17	0.417	0.15	0.1326	0.1326	0.2285
18	0.433	0.166	0.1302	0.1302	0.2243
19	0.45	0.183	0.1289	0.1289	0.2222
20	0.467	0.2	0.128	0.128	0.2206
21	0.483	0.216	0.1256	0.1256	0.2164
22	0.5	0.233	0.1244	0.1244	0.2143
23	0.517	0.25	0.1231	0.1231	0.2122
24	0.533	0.266	0.1207	0.1207	0.208
25	0.55	0.283	0.1207	0.1207	0.208
26	0.567	0.3	0.1186	0.1186	0.2043
27	0.583	0.316	0.1173	0.1173	0.2022
28	0.6	0.333	0.1161	0.1161	0.2001
29	0.617	0.35	0.1149	0.1149	0.198
30	0.633	0.366	0.1137	0.1137	0.1959
31	0.65	0.383	0.1125	0.1125	0.1938
32	0.667	0.4	0.11	0.11	0.1896
33	0.683	0.416	0.1103	0.1103	0.1901

## Greenpointe Landfill

34	0.7	0.433	0.1091	0.1091	0.188
35	0.717	0.45	0.1079	0.1079	0.1859
36	0.733	0.466	0.1067	0.1067	0.1838
37	0.75	0.483	0.1055	0.1055	0.1817
38	0.767	0.5	0.1055	0.1055	0.1817
39	0.783	0.516	0.1042	0.1042	0.1796
40	0.8	0.533	0.103	0.103	0.1775
41	0.817	0.55	0.1018	0.1018	0.1754
42	0.833	0.566	0.1018	0.1018	0.1754
43	0.85	0.583	0.1009	0.1009	0.1738
44	0.867	0.6	9.967e-002	9.967e-002	0.1717
45	0.883	0.616	9.967e-002	9.967e-002	0.1717
46	0.9	0.633	9.845e-002	9.845e-002	0.1696
47	0.917	0.65	9.845e-002	9.845e-002	0.1696
48	0.933	0.666	9.723e-002	9.723e-002	0.1675
49	0.95	0.683	9.601e-002	9.601e-002	0.1654
50	0.967	0.7	9.601e-002	9.601e-002	0.1654
51	0.983	0.716	9.479e-002	9.479e-002	0.1633
52	1.	0.733	9.357e-002	9.357e-002	0.1612
53	1.167	0.9	8.9e-002	8.9e-002	0.1534
54	1.333	1.066	8.413e-002	8.413e-002	0.145
55	1.5	1.233	8.077e-002	8.077e-002	0.1392
56	1.667	1.4	7.712e-002	7.712e-002	0.1329
57	1.833	1.566	7.468e-002	7.468e-002	0.1287
58	2.	1.733	7.224e-002	7.224e-002	0.1245
59	2.167	1.9	7.132e-002	7.132e-002	0.1229
60	2.333	2.066	7.01e-002	7.01e-002	0.1208
61	2.5	2.233	6.889e-002	6.889e-002	0.1187
62	2.667	2.4	6.767e-002	6.767e-002	0.1166

---

# Falling Head Slug Test 1/24/18

Greenpointe Landfill Anderson, SC

# Bouwer and Rice Graph

PZ-16

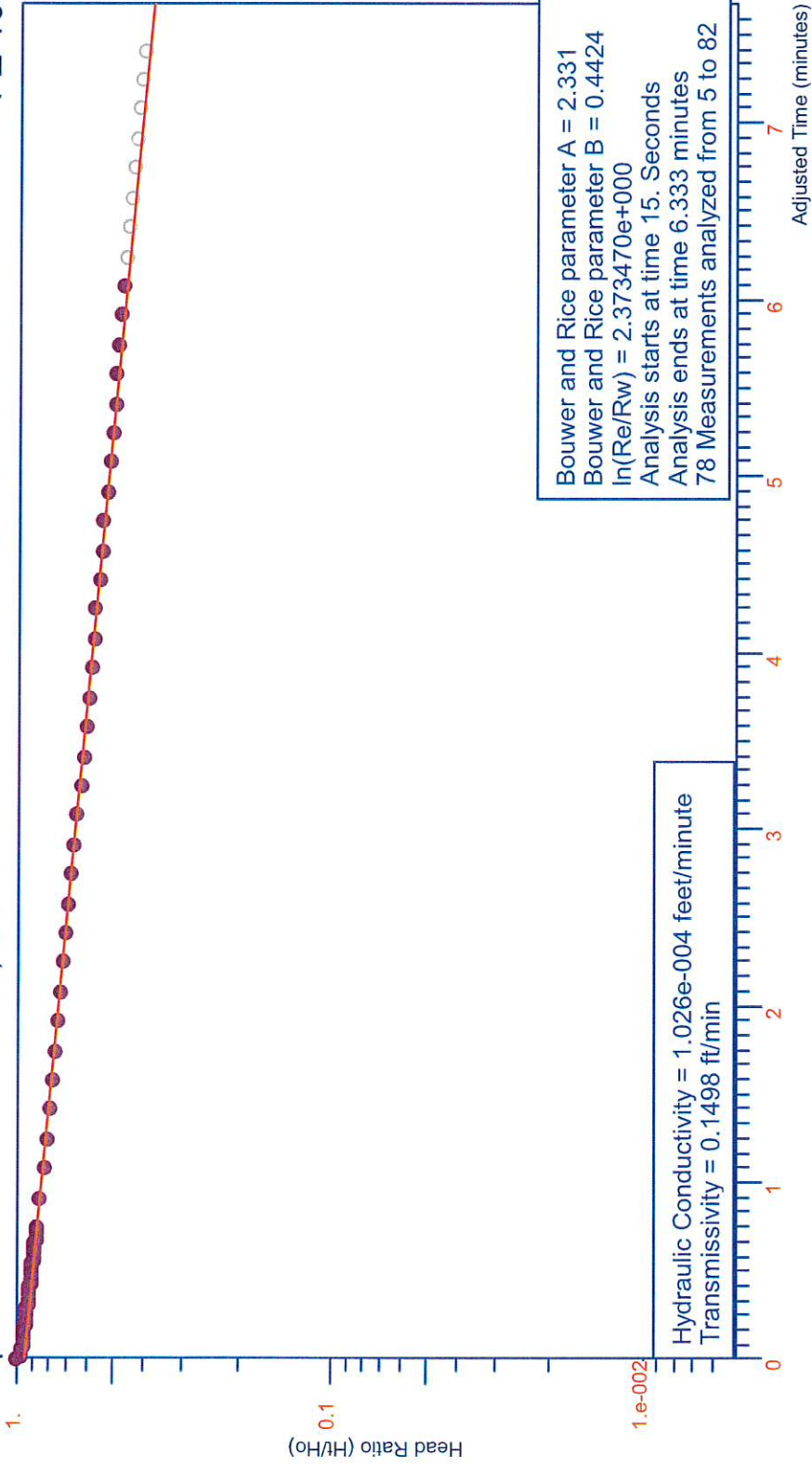

Project Number: 11684-02 for Greenpointe Landfill  
Analysis by Starpoint Software

Ho is 0.6498 Meters at 15. Seconds

**Falling Head Slug Test**

Site Name: Greenpointe Landfill  
 Location: Anderson, SC  
 Test Date: 1/24/18  
 Client: Greenpointe Landfill  
 Project Number: 11684-02  
 Import File: \\blegvlsvr1\SolidWasteProjects\Greenpointe LF, Anderson, SC\11684-02 Site Hydr

Well Label: PZ-16  
 Aquifer Thickness: 3.325 Meters  
 Screen Length: 3.048 Meters  
 Casing Radius: 2.54e-002 Meters  
 Effective Radius: 0.1048 Meters  
 Static Water Level: 0, Meters  
 Water Table to Screen Bottom: 3.048 Meters  
 Anisotropy Ratio: 2.  
 Time Adjustment: 15. Seconds

Test starts with trial 0

There are 90 time and drawdown measurements

Maximum head is 1.023 Meters

Minimum head is 0. Meters

Trial	Time (minutes)	Adjusted Time (minutes)	Drawdown (Meters)	Head (Meters)	Head Ratio
1	0.183	-6.7e-002	1.023	1.023	1.
2	0.2	-5.e-002	0.8864	0.8864	0.8662
3	0.217	-3.3e-002	0.6983	0.6983	0.6825
4	0.233	-1.7e-002	0.6014	0.6014	0.5877
5	0.25	0.	0.6498	0.6498	0.6351
6	0.267	1.7e-002	0.6264	0.6264	0.6122
7	0.283	3.3e-002	0.6334	0.6334	0.619
8	0.3	5.e-002	0.6276	0.6276	0.6133
9	0.317	6.7e-002	0.6276	0.6276	0.6133
10	0.333	8.3e-002	0.6239	0.6239	0.6098
11	0.35	1.e-001	0.6227	0.6227	0.6086
12	0.367	0.117	0.6203	0.6203	0.6062
13	0.383	0.133	0.6194	0.6194	0.6053
14	0.4	0.15	0.6181	0.6181	0.6041
15	0.417	0.167	0.6169	0.6169	0.6029
16	0.433	0.183	0.6145	0.6145	0.6005
17	0.45	0.2	0.612	0.612	0.5982
18	0.467	0.217	0.6108	0.6108	0.597
19	0.483	0.233	0.6087	0.6087	0.5949
20	0.5	0.25	0.6075	0.6075	0.5937
21	0.517	0.267	0.605	0.605	0.5913
22	0.533	0.283	0.6038	0.6038	0.5901
23	0.55	0.3	0.6026	0.6026	0.5889
24	0.567	0.317	0.6014	0.6014	0.5877
25	0.583	0.333	0.5992	0.5992	0.5856
26	0.6	0.35	0.598	0.598	0.5845
27	0.617	0.367	0.5968	0.5968	0.5833
28	0.633	0.383	0.5944	0.5944	0.5809
29	0.65	0.4	0.5931	0.5931	0.5797
30	0.667	0.417	0.5919	0.5919	0.5785
31	0.683	0.433	0.591	0.591	0.5776
32	0.7	0.45	0.5886	0.5886	0.5752
33	0.717	0.467	0.5874	0.5874	0.574

Greenpointe Landfill

34	0.733	0.483	0.5849	0.5849	0.5716
35	0.75	0.5	0.5837	0.5837	0.5704
36	0.767	0.517	0.5825	0.5825	0.5693
37	0.783	0.533	0.5816	0.5816	0.5684
38	0.8	0.55	0.5803	0.5803	0.5672
39	0.817	0.567	0.5779	0.5779	0.5648
40	0.833	0.583	0.5767	0.5767	0.5636
41	0.85	0.6	0.5755	0.5755	0.5624
42	0.867	0.617	0.5743	0.5743	0.5612
43	0.883	0.633	0.5721	0.5721	0.5591
44	0.9	0.65	0.5709	0.5709	0.5579
45	0.917	0.667	0.5697	0.5697	0.5567
46	0.933	0.683	0.5685	0.5685	0.5556
47	0.95	0.7	0.5672	0.5672	0.5544
48	0.967	0.717	0.566	0.566	0.5532
49	0.983	0.733	0.5636	0.5636	0.5508
50	1.	0.75	0.5627	0.5627	0.5499
51	1.167	0.917	0.5496	0.5496	0.5371
52	1.333	1.083	0.5365	0.5365	0.5243
53	1.5	1.25	0.5246	0.5246	0.5127
54	1.667	1.417	0.5142	0.5142	0.5025
55	1.833	1.583	0.5035	0.5035	0.4921
56	2.	1.75	0.4929	0.4929	0.4817
57	2.167	1.917	0.4834	0.4834	0.4724
58	2.333	2.083	0.474	0.474	0.4632
59	2.5	2.25	0.4645	0.4645	0.454
60	2.667	2.417	0.4551	0.4551	0.4447
61	2.833	2.583	0.4456	0.4456	0.4355
62	3.	2.75	0.4374	0.4374	0.4275
63	3.167	2.917	0.4292	0.4292	0.4194
64	3.333	3.083	0.4206	0.4206	0.4111
65	3.5	3.25	0.4124	0.4124	0.403
66	3.667	3.417	0.4042	0.4042	0.395
67	3.833	3.583	0.3972	0.3972	0.3881
68	4.	3.75	0.3889	0.3889	0.3801
69	4.167	3.917	0.3816	0.3816	0.373
70	4.333	4.083	0.3746	0.3746	0.3661
71	4.5	4.25	0.3685	0.3685	0.3601
72	4.667	4.417	0.3603	0.3603	0.3521
73	4.833	4.583	0.3545	0.3545	0.3464
74	5.	4.75	0.3487	0.3487	0.3408
75	5.167	4.917	0.3414	0.3414	0.3336
76	5.333	5.083	0.3344	0.3344	0.3268
77	5.5	5.25	0.3286	0.3286	0.3211
78	5.667	5.417	0.3225	0.3225	0.3152
79	5.833	5.583	0.3167	0.3167	0.3095
80	6.	5.75	0.3118	0.3118	0.3047
81	6.167	5.917	0.306	0.306	0.2991
82	6.333	6.083	0.2999	0.2999	0.2931
83	6.5	6.25	0.2941	0.2941	0.2875
84	6.667	6.417	0.2893	0.2893	0.2827
85	6.833	6.583	0.2835	0.2835	0.277
86	7.	6.75	0.2786	0.2786	0.2723
87	7.167	6.917	0.274	0.274	0.2678
88	7.333	7.083	0.2694	0.2694	0.2633
89	7.5	7.25	0.2646	0.2646	0.2586
90	7.667	7.417	0.26	0.26	0.2541



# Falling Head Slug Test 1/24/18

Greenpointe Landfill Anderson, SC

# Bouwer and Rice Graph

PZ-18

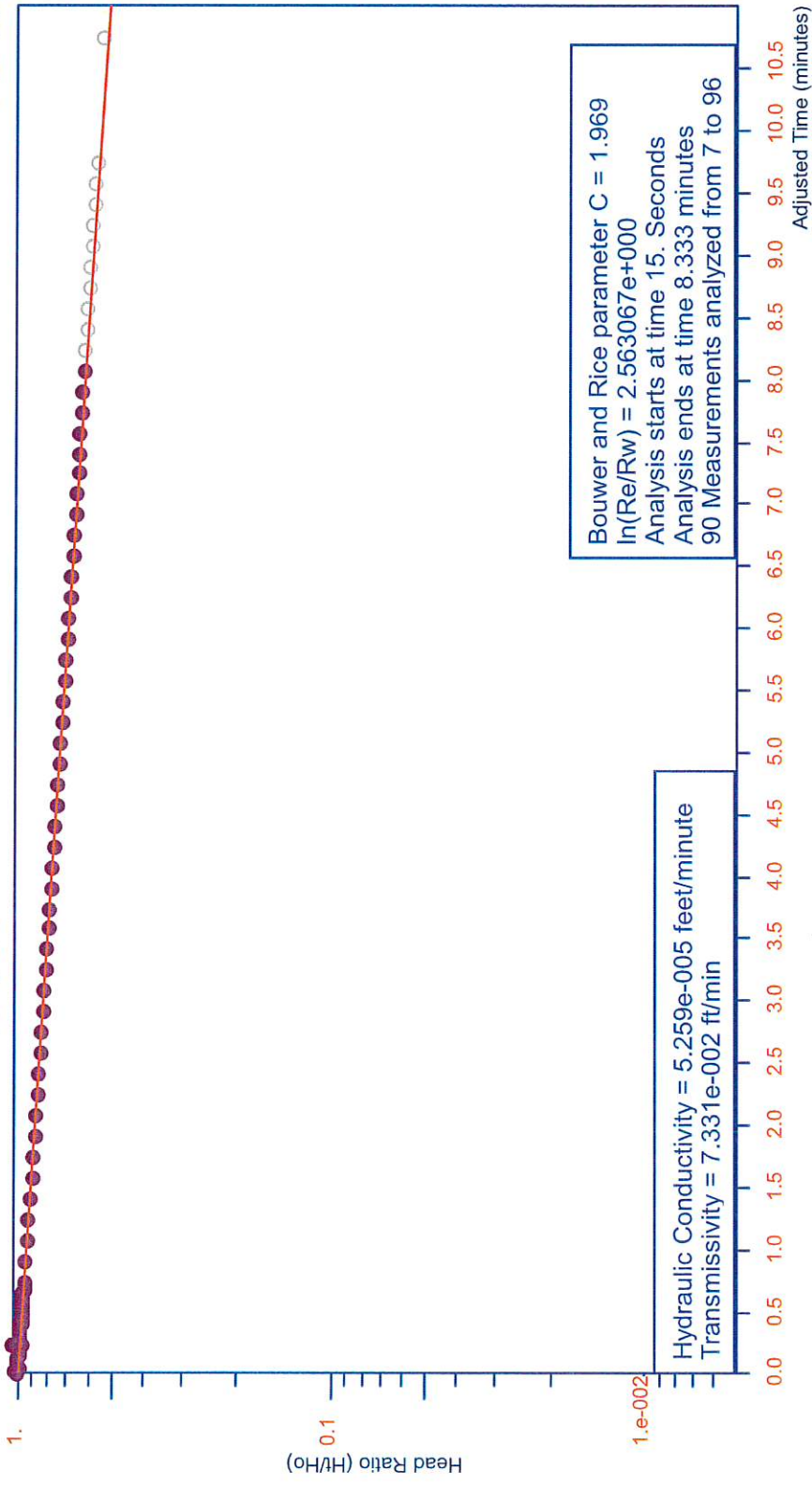

Project Number: 11684-02 for Greenpointe Landfill  
Analysis by Starpoint Software

**Falling Head Slug Test**

Site Name: Greenpointe Landfill  
 Location: Anderson, SC  
 Test Date: 1/24/18  
 Client: Greenpointe Landfill  
 Project Number: 11684-02  
 Import File: \\blegvlsvr1\SolidWasteProjects\Greenpointe LF, Anderson, SC\11684-02 Site Hydr

Well Label: PZ-18  
 Aquifer Thickness: 3.176 Meters  
 Screen Length: 3.048 Meters  
 Casing Radius: 2.54e-002 Meters  
 Effective Radius: 0.1048 Meters  
 Static Water Level: 0. Meters  
 Water Table to Screen Bottom: 3.176 Meters  
 Anisotropy Ratio: 2.  
 Time Adjustment: 15. Seconds

Test starts with trial 0

There are 107 time and drawdown measurements

Maximum head is 0.8946 Meters

Minimum head is 0. Meters

Trial	Time (minutes)	Adjusted Time (minutes)	Drawdown (Meters)	Head (Meters)	Head Ratio
1	0.15	-0.1	0.8946	0.8946	1.
2	0.167	-8.3e-002	0.8617	0.8617	0.9632
3	0.183	-6.7e-002	0.5685	0.5685	0.6354
4	0.2	-5.e-002	0.6334	0.6334	0.708
5	0.217	-3.3e-002	0.5721	0.5721	0.6395
6	0.233	-1.7e-002	0.5791	0.5791	0.6474
7	0.25	0.	0.5721	0.5721	0.6395
8	0.267	1.7e-002	0.5685	0.5685	0.6354
9	0.283	3.3e-002	0.5767	0.5767	0.6446
10	0.3	5.e-002	0.5614	0.5614	0.6276
11	0.317	6.7e-002	0.5651	0.5651	0.6317
12	0.333	8.3e-002	0.566	0.566	0.6327
13	0.35	1.e-001	0.5639	0.5639	0.6303
14	0.367	0.117	0.5639	0.5639	0.6303
15	0.383	0.133	0.5639	0.5639	0.6303
16	0.4	0.15	0.5627	0.5627	0.629
17	0.417	0.167	0.5614	0.5614	0.6276
18	0.433	0.183	0.5602	0.5602	0.6262
19	0.45	0.2	0.5602	0.5602	0.6262
20	0.467	0.217	0.5569	0.5569	0.6225
21	0.483	0.233	0.5852	0.5852	0.6542
22	0.5	0.25	0.5426	0.5426	0.6065
23	0.517	0.267	0.559	0.559	0.6249
24	0.533	0.283	0.5569	0.5569	0.6225
25	0.55	0.3	0.5569	0.5569	0.6225
26	0.567	0.317	0.5557	0.5557	0.6211
27	0.583	0.333	0.5557	0.5557	0.6211
28	0.6	0.35	0.5544	0.5544	0.6198
29	0.617	0.367	0.5532	0.5532	0.6184
30	0.633	0.383	0.5532	0.5532	0.6184
31	0.65	0.4	0.5532	0.5532	0.6184
32	0.667	0.417	0.552	0.552	0.617
33	0.683	0.433	0.5508	0.5508	0.6157

## Greenpointe Landfill

34	0.7	0.45	0.5508	0.5508	0.6157
35	0.717	0.467	0.5499	0.5499	0.6147
36	0.733	0.483	0.5499	0.5499	0.6147
37	0.75	0.5	0.5486	0.5486	0.6133
38	0.767	0.517	0.5486	0.5486	0.6133
39	0.783	0.533	0.5474	0.5474	0.6119
40	0.8	0.55	0.5474	0.5474	0.6119
41	0.817	0.567	0.5462	0.5462	0.6106
42	0.833	0.583	0.5462	0.5462	0.6106
43	0.85	0.6	0.545	0.545	0.6092
44	0.867	0.617	0.5438	0.5438	0.6078
45	0.883	0.633	0.5438	0.5438	0.6078
46	0.9	0.65	0.5438	0.5438	0.6078
47	0.917	0.667	0.5426	0.5426	0.6065
48	0.933	0.683	0.5413	0.5413	0.6051
49	0.95	0.7	0.5416	0.5416	0.6055
50	0.967	0.717	0.5404	0.5404	0.6041
51	0.983	0.733	0.5404	0.5404	0.6041
52	1.	0.75	0.5392	0.5392	0.6027
53	1.167	0.917	0.5331	0.5331	0.5959
54	1.333	1.083	0.5285	0.5285	0.5908
55	1.5	1.25	0.5224	0.5224	0.584
56	1.667	1.417	0.5166	0.5166	0.5775
57	1.833	1.583	0.5109	0.5109	0.571
58	2.	1.75	0.506	0.506	0.5656
59	2.167	1.917	0.5014	0.5014	0.5605
60	2.333	2.083	0.4965	0.4965	0.555
61	2.5	2.25	0.492	0.492	0.5499
62	2.667	2.417	0.4862	0.4862	0.5434
63	2.833	2.583	0.4825	0.4825	0.5394
64	3.	2.75	0.4779	0.4779	0.5342
65	3.167	2.917	0.4718	0.4718	0.5274
66	3.333	3.083	0.4685	0.4685	0.5237
67	3.5	3.25	0.4636	0.4636	0.5182
68	3.667	3.417	0.4599	0.4599	0.5141
69	3.833	3.583	0.4554	0.4554	0.509
70	4.	3.75	0.4508	0.4508	0.5039
71	4.167	3.917	0.4459	0.4459	0.4985
72	4.333	4.083	0.4426	0.4426	0.4947
73	4.5	4.25	0.4377	0.4377	0.4893
74	4.667	4.417	0.4343	0.4343	0.4855
75	4.833	4.583	0.4295	0.4295	0.4801
76	5.	4.75	0.4258	0.4258	0.476
77	5.167	4.917	0.4225	0.4225	0.4722
78	5.333	5.083	0.4176	0.4176	0.4668
79	5.5	5.25	0.4139	0.4139	0.4627
80	5.667	5.417	0.4106	0.4106	0.4589
81	5.833	5.583	0.4069	0.4069	0.4549
82	6.	5.75	0.4023	0.4023	0.4497
83	6.167	5.917	0.3987	0.3987	0.4457
84	6.333	6.083	0.395	0.395	0.4416
85	6.5	6.25	0.3917	0.3917	0.4378
86	6.667	6.417	0.388	0.388	0.4337
87	6.833	6.583	0.3844	0.3844	0.4296
88	7.	6.75	0.381	0.381	0.4259
89	7.167	6.917	0.3773	0.3773	0.4218
90	7.333	7.083	0.3737	0.3737	0.4177

Greenpointe Landfill

91	7.5	7.25	0.3703	0.3703	0.414
92	7.667	7.417	0.3667	0.3667	0.4099
93	7.833	7.583	0.3642	0.3642	0.4072
94	8.	7.75	0.3609	0.3609	0.4034
95	8.167	7.917	0.3572	0.3572	0.3993
96	8.333	8.083	0.3539	0.3539	0.3956
97	8.5	8.25	0.3514	0.3514	0.3928
98	8.667	8.417	0.349	0.349	0.3901
99	8.833	8.583	0.3453	0.3453	0.386
100	9.	8.75	0.342	0.342	0.3823
101	9.167	8.917	0.3396	0.3396	0.3796
102	9.333	9.083	0.3359	0.3359	0.3755
103	9.5	9.25	0.3325	0.3325	0.3717
104	9.667	9.417	0.3301	0.3301	0.369
105	9.833	9.583	0.3264	0.3264	0.3649
106	10.	9.75	0.3243	0.3243	0.3625
107	11.	10.75	0.3079	0.3079	0.3441

---

# Falling Head Slug Test 1/24/18

Greenpointe Landfill Anderson, SC

# Bouwer and Rice Graph

PZ-20

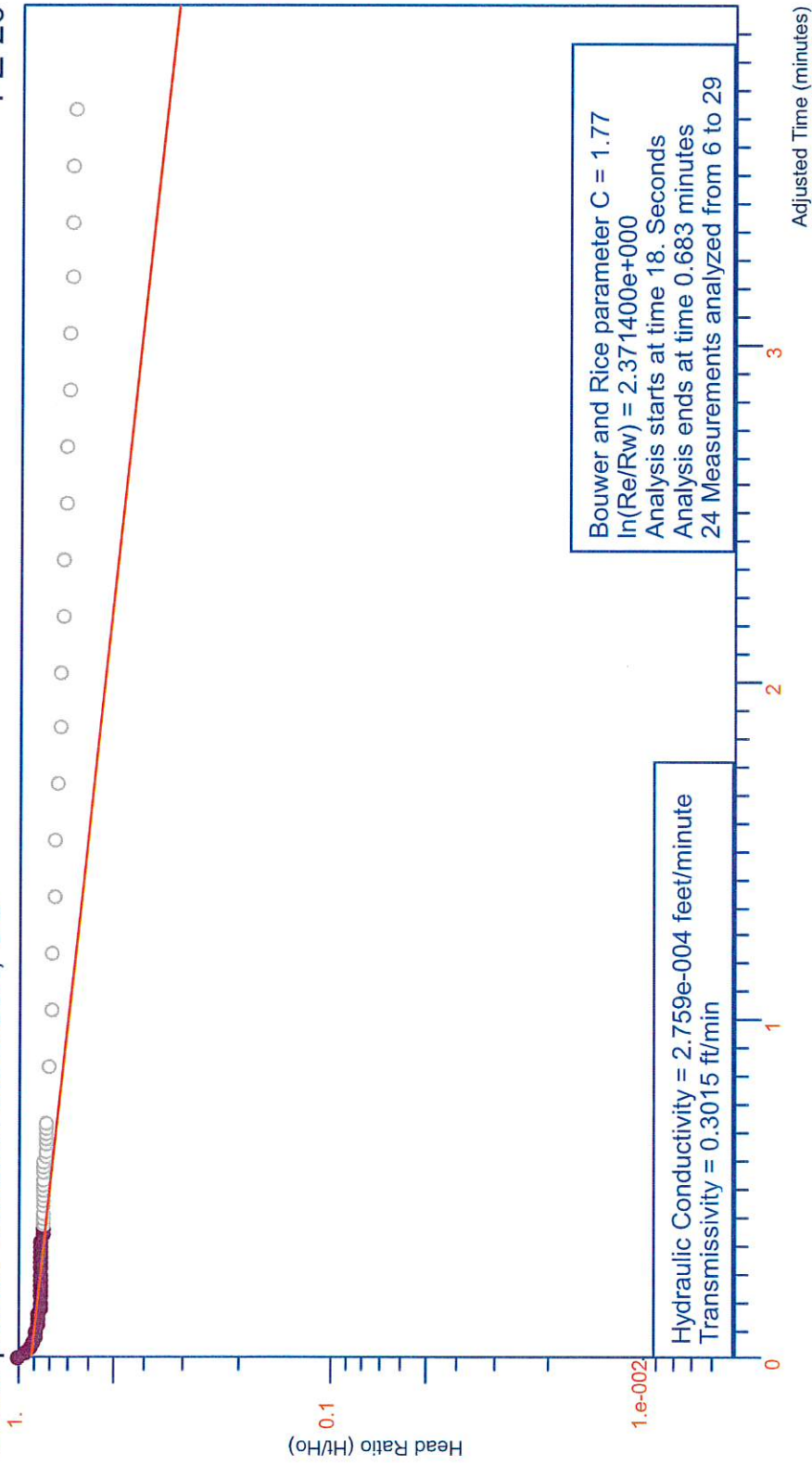

Project Number: 11684-02 for Greenpointe Landfill  
Analysis by Starpoint Software

Ho is 0.2012 Meters at 18. Seconds

**Falling Head Slug Test**

Site Name: Greenpointe Landfill  
 Location: Anderson, SC  
 Test Date: 1/24/18  
 Client: Greenpointe Landfill  
 Project Number: 11684-02  
 Import File: \\blegvlsvr1\SolidWasteProjects\Greenpointe LF, Anderson, SC\11684-02 Site Hydr

Well Label: PZ-20  
 Aquifer Thickness: 2.49 Meters  
 Screen Length: 2.49 Meters  
 Casing Radius: 2.54e-002 Meters  
 Effective Radius: 0.1048 Meters  
 Static Water Level: 0. Meters  
 Water Table to Screen Bottom: 2.49 Meters  
 Anisotropy Ratio: 2.  
 Time Adjustment: 18. Seconds

Test starts with trial 0

There are 66 time and drawdown measurements

Maximum head is 0.8855 Meters

Minimum head is 0. Meters

Trial	Time (minutes)	Adjusted Time (minutes)	Drawdown (Meters)	Head (Meters)	Head Ratio
1	0.217	-8.3e-002	0.8855	0.8855	1.
2	0.233	-6.7e-002	0.4185	0.4185	0.4726
3	0.25	-5.e-002	0.2923	0.2923	0.3301
4	0.267	-3.3e-002	0.2496	0.2496	0.2819
5	0.283	-1.7e-002	0.2213	0.2213	0.2499
6	0.3	0.	0.2012	0.2012	0.2272
7	0.317	1.7e-002	0.1905	0.1905	0.2151
8	0.333	3.3e-002	0.1835	0.1835	0.2072
9	0.35	5.e-002	0.1798	0.1798	0.2031
10	0.367	6.7e-002	0.1777	0.1777	0.2007
11	0.383	8.3e-002	0.1765	0.1765	0.1993
12	0.4	0.1	0.1753	0.1753	0.1979
13	0.417	0.117	0.174	0.174	0.1966
14	0.433	0.133	0.174	0.174	0.1966
15	0.45	0.15	0.1728	0.1728	0.1952
16	0.467	0.167	0.1728	0.1728	0.1952
17	0.483	0.183	0.1728	0.1728	0.1952
18	0.5	0.2	0.1728	0.1728	0.1952
19	0.517	0.217	0.1728	0.1728	0.1952
20	0.533	0.233	0.1716	0.1716	0.1938
21	0.55	0.25	0.1716	0.1716	0.1938
22	0.567	0.267	0.1716	0.1716	0.1938
23	0.583	0.283	0.1704	0.1704	0.1924
24	0.6	0.3	0.1716	0.1716	0.1938
25	0.617	0.317	0.1704	0.1704	0.1924
26	0.633	0.333	0.1704	0.1704	0.1924
27	0.65	0.35	0.1704	0.1704	0.1924
28	0.667	0.367	0.1695	0.1695	0.1914
29	0.683	0.383	0.1695	0.1695	0.1914
30	0.7	0.4	0.1695	0.1695	0.1914
31	0.717	0.417	0.1683	0.1683	0.19
32	0.733	0.433	0.1683	0.1683	0.19
33	0.75	0.45	0.1683	0.1683	0.19

Greenpointe Landfill

34	0.767	0.467	0.1683	0.1683	0.19
35	0.783	0.483	0.1683	0.1683	0.19
36	0.8	0.5	0.1683	0.1683	0.19
37	0.817	0.517	0.167	0.167	0.1886
38	0.833	0.533	0.167	0.167	0.1886
39	0.85	0.55	0.167	0.167	0.1886
40	0.867	0.567	0.167	0.167	0.1886
41	0.883	0.583	0.167	0.167	0.1886
42	0.9	0.6	0.1658	0.1658	0.1873
43	0.917	0.617	0.1658	0.1658	0.1873
44	0.933	0.633	0.1658	0.1658	0.1873
45	0.95	0.65	0.1658	0.1658	0.1873
46	0.967	0.667	0.1658	0.1658	0.1873
47	0.983	0.683	0.1646	0.1646	0.1859
48	1.	0.7	0.1646	0.1646	0.1859
49	1.167	0.867	0.1625	0.1625	0.1835
50	1.333	1.033	0.16	0.16	0.1807
51	1.5	1.2	0.1588	0.1588	0.1793
52	1.667	1.367	0.1567	0.1567	0.1769
53	1.833	1.533	0.1554	0.1554	0.1756
54	2.	1.7	0.153	0.153	0.1728
55	2.167	1.867	0.1506	0.1506	0.1701
56	2.333	2.033	0.1494	0.1494	0.1687
57	2.5	2.2	0.1484	0.1484	0.1676
58	2.667	2.367	0.146	0.146	0.1649
59	2.833	2.533	0.1448	0.1448	0.1635
60	3.	2.7	0.1436	0.1436	0.1621
61	3.167	2.867	0.1423	0.1423	0.1608
62	3.333	3.033	0.1411	0.1411	0.1594
63	3.5	3.2	0.1402	0.1402	0.1583
64	3.667	3.367	0.1402	0.1402	0.1583
65	3.833	3.533	0.139	0.139	0.157
66	4.	3.7	0.1378	0.1378	0.1556

---

# Falling Head Slug Test 1/24/18

Greenpointe Landfill Anderson, SC

# Bouwer and Rice Graph

PZ-23

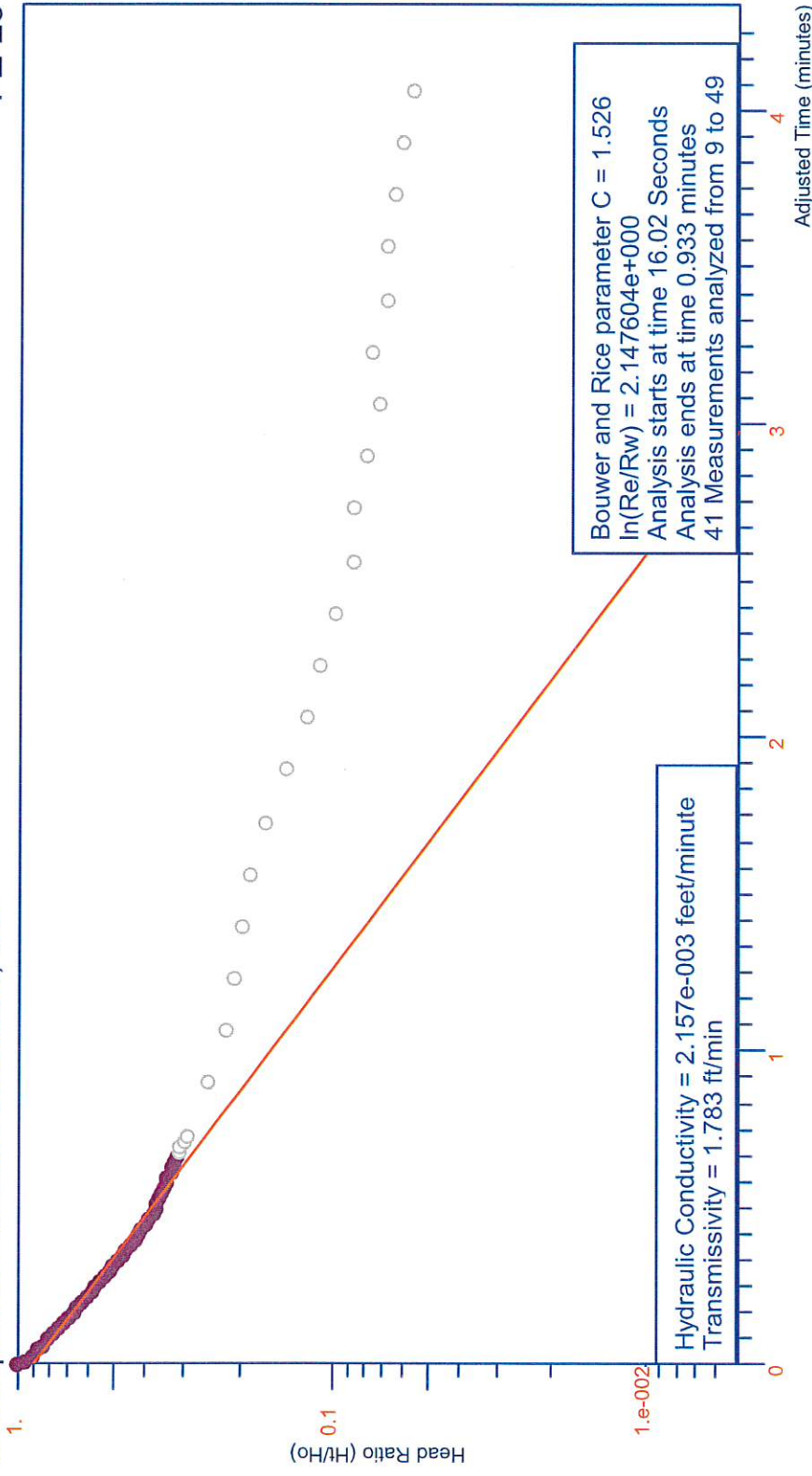

Project Number: 11684-02 for Greenpointe Landfill  
Analysis by Starpoint Software



**Falling Head Slug Test**

Site Name: Greenpointe Landfill  
 Location: Anderson, SC  
 Test Date: 1/24/18  
 Client: Greenpointe Landfill  
 Project Number: 11684-02  
 Import File: \\blegvlsvr1\SolidWasteProjects\Greenpointe LF, Anderson, SC\11684-02 Site Hydr

Well Label: PZ-23  
 Aquifer Thickness: 1.884 Meters  
 Screen Length: 1.884 Meters  
 Casing Radius: 2.54e-002 Meters  
 Effective Radius: 0.1048 Meters  
 Static Water Level: 0. Meters  
 Water Table to Screen Bottom: 1.884 Meters  
 Anisotropy Ratio: 2.  
 Time Adjustment: 16.02 Seconds

Test starts with trial 0

There are 73 time and drawdown measurements

Maximum head is 0.791 Meters

Minimum head is 0. Meters

Trial	Time (minutes)	Adjusted Time (minutes)	Drawdown (Meters)	Head (Meters)	Head Ratio
1	0.133	-0.134	0.791	0.791	1.
2	0.15	-0.117	0.4907	0.4907	0.6204
3	0.167	-0.1	0.5807	0.5807	0.7341
4	0.183	-8.4e-002	0.492	0.492	0.622
5	0.2	-6.7e-002	0.4246	0.4246	0.5368
6	0.217	-5.e-002	0.3819	0.3819	0.4829
7	0.233	-3.4e-002	0.349	0.349	0.4412
8	0.25	-1.7e-002	0.3264	0.3264	0.4127
9	0.267	0.	0.3088	0.3088	0.3904
10	0.283	1.6e-002	0.2923	0.2923	0.3696
11	0.3	3.3e-002	0.2792	0.2792	0.353
12	0.317	5.e-002	0.2673	0.2673	0.338
13	0.333	6.6e-002	0.2569	0.2569	0.3249
14	0.35	8.3e-002	0.2475	0.2475	0.3129
15	0.367	1.e-001	0.2381	0.2381	0.301
16	0.383	0.116	0.2295	0.2295	0.2902
17	0.4	0.133	0.2237	0.2237	0.2829
18	0.417	0.15	0.2143	0.2143	0.2709
19	0.433	0.166	0.2073	0.2073	0.262
20	0.45	0.183	0.2003	0.2003	0.2532
21	0.467	0.2	0.1929	0.1929	0.2439
22	0.483	0.216	0.1871	0.1871	0.2366
23	0.5	0.233	0.1814	0.1814	0.2293
24	0.517	0.25	0.1753	0.1753	0.2216
25	0.533	0.266	0.1695	0.1695	0.2143
26	0.55	0.283	0.1646	0.1646	0.2081
27	0.567	0.3	0.1588	0.1588	0.2008
28	0.583	0.316	0.1542	0.1542	0.195
29	0.6	0.333	0.1481	0.1481	0.1873
30	0.617	0.35	0.1436	0.1436	0.1815
31	0.633	0.366	0.1399	0.1399	0.1769
32	0.65	0.383	0.1353	0.1353	0.1711
33	0.667	0.4	0.1317	0.1317	0.1665

Greenpointe Landfill

34	0.683	0.416	0.128	0.128	0.1618
35	0.7	0.433	0.1247	0.1247	0.1576
36	0.717	0.45	0.121	0.121	0.153
37	0.733	0.466	0.1186	0.1186	0.1499
38	0.75	0.483	0.1152	0.1152	0.1457
39	0.767	0.5	0.1128	0.1128	0.1426
40	0.783	0.516	0.1116	0.1116	0.141
41	0.8	0.533	0.1091	0.1091	0.138
42	0.817	0.55	0.1082	0.1082	0.1368
43	0.833	0.566	0.107	0.107	0.1353
44	0.85	0.583	0.1045	0.1045	0.1322
45	0.867	0.6	0.1033	0.1033	0.1306
46	0.883	0.616	0.1009	0.1009	0.1276
47	0.9	0.633	9.967e-002	9.967e-002	0.126
48	0.917	0.65	9.754e-002	9.754e-002	0.1233
49	0.933	0.666	9.632e-002	9.632e-002	0.1218
50	0.95	0.683	9.51e-002	9.51e-002	0.1202
51	0.967	0.7	9.388e-002	9.388e-002	0.1187
52	0.983	0.716	9.144e-002	9.144e-002	0.1156
53	1.	0.733	9.022e-002	9.022e-002	0.1141
54	1.167	0.9	7.742e-002	7.742e-002	9.788e-002
55	1.333	1.066	6.675e-002	6.675e-002	8.439e-002
56	1.5	1.233	6.309e-002	6.309e-002	7.977e-002
57	1.667	1.4	6.066e-002	6.066e-002	7.669e-002
58	1.833	1.566	5.73e-002	5.73e-002	7.245e-002
59	2.	1.733	5.029e-002	5.029e-002	6.358e-002
60	2.167	1.9	4.328e-002	4.328e-002	5.472e-002
61	2.333	2.066	3.719e-002	3.719e-002	4.701e-002
62	2.5	2.233	3.383e-002	3.383e-002	4.277e-002
63	2.667	2.4	3.018e-002	3.018e-002	3.815e-002
64	2.833	2.566	2.682e-002	2.682e-002	3.391e-002
65	3.	2.733	2.682e-002	2.682e-002	3.391e-002
66	3.167	2.9	2.438e-002	2.438e-002	3.083e-002
67	3.333	3.066	2.195e-002	2.195e-002	2.775e-002
68	3.5	3.233	2.317e-002	2.317e-002	2.929e-002
69	3.667	3.4	2.073e-002	2.073e-002	2.62e-002
70	3.833	3.566	2.073e-002	2.073e-002	2.62e-002
71	4.	3.733	1.951e-002	1.951e-002	2.466e-002
72	4.167	3.9	1.859e-002	1.859e-002	2.351e-002
73	4.333	4.066	1.737e-002	1.737e-002	2.197e-002

**APPENDIX D**  
**Soil Laboratory Test Procedures and Results**

## APPENDIX D

### SOIL LABORATORY TEST PROCEDURES

#### MOISTURE CONTENT AND UNIT WEIGHT

An undisturbed sample is trimmed in the laboratory into a right circular cylinder approximately three to six inches long. The dimensions and weight of the specimen are determined and the total unit weight calculated. Moisture contents are determined from representative portions of the specimen. The soil is dried to a constant weight in an oven at 100 degrees C and the loss of moisture during the drying process is measured. From this data, the moisture content and dry unit weight are computed.

#### ATTERBERG LIMITS

The Atterberg Limits Tests, Liquid Limit (LL), and Plastic Limit (PL), are performed to aid in the classification of soils and to determine the plasticity and volume change characteristics of the materials. The Liquid Limit is the minimum moisture content at which a soil will flow as a heavy viscous fluid. The Plastic Limit is the minimum moisture content at which the solid behaves as a plastic material. The Plasticity Index (PI) is the numeric difference of Liquid Limit and the Plastic Limit and indicates the range of moisture content over which a soil remains plastic. These tests are performed in accordance with ASTM D 4318.

#### PARTICLE SIZE DISTRIBUTION

The distribution of soils coarser than the No. 200 (75-um) sieve is determined by passing a representative specimen through a standard set of nested sieves. The weight of material retained on each sieve is determined and the percentage retained (or passing) is calculated. A specimen may be washed through only the No. 200 sieve, if the full range of particle sizes is not required. The percentage of material passing the No. 200 sieve is reported. The distribution of materials finer than No. 200 sieve is determined by use of the hydrometer. The particle sizes and distribution are computed from the time rate of settlement of the different size particles while suspended in water. These tests are performed in accordance with ASTM D 421, D 422, and D 1140.

#### HYDRAULIC CONDUCTIVITY

The ease with which water flows through a soil is characterized by its hydraulic conductivity. Two general test methods are employed depending on the soil type.

The **Constant Head** method is used for coarse-grained materials (sands and gravels). The sample is confined in permeameter chamber while water is allowed to flow through it from a constant head level. The quantity of water flowing through the specimen in a given time period is used to calculate the hydraulic conductivity. See ASTM D 2434 for a complete description of this test.

Fine-grained materials (silts and clays) require the use of a **Flexible Wall Permeameter**. The sample is prepared in a similar manner as in the triaxial compression test. It is encased in a rubber membrane and placed inside a permeameter chamber. The specimen is backpressure saturated and allowed to consolidate under a specified effective stress. Water is then forced through the specimen under a controlled hydraulic gradient. The quantity of water flowing into the sample in a

given time period is used to calculate the hydraulic conductivity. This test is performed in general accordance with ASTM D 5084.

### **CONSOLIDATION**

A single section of the undisturbed sample was extruded from its sampling tube for consolidation testing. The sample was then trimmed into a disc 2.4 inches in diameter and 1 inch thick. The disc was confined in a stainless steel ring and sandwiched between porous plates. It was then subjected to incrementally increasing vertical loads and the resulting deformations measured with a micrometer dial gauge. The test results are presented in the form of a pressure versus percent strain curve on the accompanying Consolidation Test sheet.

### **TRIAXIAL SHEAR**

Several sections of the undisturbed sample were extruded from their sampling tubes for triaxial shear testing. The sections were then trimmed into cylinders 2.4 inches in diameter and encased in rubber membranes. Each was then placed in a compression chamber and confined by all around water pressure. An increasing axial load was then applied until the sample failed in shear. The test results are presented in the form of Stress-Strain Curves and Mohr Diagrams on the accompanying Triaxial Shear Test sheets.

**HYDRAULIC CONDUCTIVITY TEST REPORT**  
 CONSTANT VOLUME APPARATUS (ASTM D 5084)

PROJECT: GREENPOINT LANDFILL  
 PROJECT NO.: J17-11684-02  
 DATE RECEIVED: 12-20-17

TESTED BY: JOHN MATHEW  
 CHECKED BY: PAUL YARBER

SAMPLE NO. <u>PZ-16</u>	SAMPLE LOCATION: <u>2.0-4.0'</u>
TYPE <u>UNDISTURBED</u>	SAMPLE DESCRIPTION: <u>YELLOWISH BROWN FL.-MED. SANDY ELASTIC SILT</u>

**SAMPLE DIMENSIONS AND PROPERTIES**

ITEM	INITIAL		FINAL	
	inches	centimeters	inches	centimeters
Sample Length	2.923	7.424	2.893	7.348
Sample Diameter	2.861	7.267	2.838	7.209
Length/Diameter Ratio		1.02		
Moisture Content (%)	WW= 180.4 DW= 131.1	37.6	WW= 241.8 DW= 177.0	36.6
Sample Wet Weight (grams)	548.4		547.7	
Wet Density (pcf)	111.2		114.0	
Dry Density (pcf)	80.8		83.5	
Saturation (%)	93		97	

**HYDRAULIC CONDUCTIVITY TESTING MEASUREMENT**  
 (PERMOMETER)

Chamber Pressure (psi)	70	Influent Pressure (psi)	60	Effluent Pressure (psi)	60	B-Value	0.96			
Reset (Y/N)	Date	Clock Time	Elapsed Time	HA <sub>OUT</sub> (cm)	HA <sub>IN</sub> (cm)	Temp °C	Gradient	K (cm/sec)	Temp Correction	K <sub>20°C</sub> (cm/sec)
Y	12-21-17	2:45:40		4.7	1.99	22.0	5			
	12-21-17	2:47:51	0:02:11	4.0	2.02	22.0	4	1.0E-06	0.953	9.9E-07
	12-21-17	2:48:14	0:02:34	3.9	2.03	22.0	4	1.0E-06	0.953	9.8E-07
	12-21-17	2:48:40	0:03:00	3.8	2.03	22.0	3	1.0E-06	0.953	9.7E-07
	12-21-17	2:49:05	0:03:25	3.7	2.03	22.0	3	1.0E-06	0.953	9.7E-07

**HYDRAULIC CONDUCTIVITY (K<sub>20°C</sub>)      9.8E-07      cm/sec**

**HYDRAULIC CONDUCTIVITY TEST REPORT**  
 CONSTANT VOLUME APPARATUS (ASTM D 5084)

PROJECT: GREENPOINT LANDFILL  
 PROJECT NO.: J17-11684-02  
 DATE RECEIVED: 12-20-17

TESTED BY: JOHN MATHEW  
 CHECKED BY: PAUL YARBER

SAMPLE NO. <u>PZ-17</u>	SAMPLE LOCATION: <u>3.0-5.0'</u>
TYPE <u>UNDISTURBED</u>	SAMPLE DESCRIPTION: <u>GREY YELLOW &amp; BROWN FL-MED. SANDY CLAY</u>

**SAMPLE DIMENSIONS AND PROPERTIES**

ITEM	INITIAL		FINAL	
	inches	centimeters	inches	centimeters
Sample Length	2.967	7.536	2.952	7.498
Sample Diameter	2.856	7.254	2.854	7.249
Length/Diameter Ratio		1.04		
Moisture Content (%)	WW= 157.1 DW= 124.9	25.8	WW= 225.5 DW= 176.5	27.8
Sample Wet Weight (grams)	615.0		621.3	
Wet Density (pcf)	123.3		125.3	
Dry Density (pcf)	98.0		98.1	
Saturation (%)	TESTED SG= 2.71	96	104	

**HYDRAULIC CONDUCTIVITY TESTING MEASUREMENT**  
 (PERMOMETER)

Chamber Pressure (psi)	70	Influent Pressure (psi)	60	Effluent Pressure (psi)	60	B-Value	0.96			
Reset (Y/N)	Date	Clock Time	Elapsed Time	HA <sub>OUT</sub> (cm)	HA <sub>IN</sub> (cm)	Temp °C	Gradient	K (cm/sec)	Temp Correction	K <sub>20°C</sub> (cm/sec)
Y	12-22-17	8:26:33		7.7	1.87	21.0	10			
	12-22-17	8:31:52	0:05:19	6.8	1.91	21.0	9	2.4E-07	0.976	2.3E-07
	12-22-17	8:32:31	0:05:58	6.7	1.91	21.0	8	2.4E-07	0.976	2.3E-07
	12-22-17	8:33:12	0:06:39	6.6	1.92	21.0	8	2.4E-07	0.976	2.3E-07
	12-22-17	8:34:00	0:07:27	6.5	1.92	21.0	8	2.4E-07	0.976	2.3E-07

**HYDRAULIC CONDUCTIVITY (K<sub>20°C</sub>)      2.3E-07      cm/sec**

**HYDRAULIC CONDUCTIVITY TEST REPORT**  
 CONSTANT VOLUME APPARATUS (ASTM D 5084)

PROJECT: GREENPOINT LANDFILL  
 PROJECT NO.: J17-11684-02  
 DATE RECEIVED: 12-20-17

TESTED BY: JOHN MATHEW  
 CHECKED BY: PAUL YARBER

SAMPLE NO. <u>PZ-20</u>	SAMPLE LOCATION: <u>10.0-12.0'</u>
TYPE <u>UNDISTURBED</u>	SAMPLE DESCRIPTION: <u>YELLOW &amp; BROWN FL.-MED. SANDY ELASTIC SILT</u>

**SAMPLE DIMENSIONS AND PROPERTIES**

ITEM	INITIAL		FINAL	
	inches	centimeters	inches	centimeters
Sample Length	2.896	7.356	2.865	7.277
Sample Diameter	2.851	7.242	2.844	7.224
Length/Diameter Ratio		1.02		
Moisture Content (%)	WW= 174.8 DW= 123.8	41.2	WW= 174.4 DW= 122.7	42.1
Sample Wet Weight (grams)	534.8		534.8	
Wet Density (pcf)	110.2		111.9	
Dry Density (pcf)	78.0		78.8	
Saturation (%)	TESTED SG= 2.71	96	100	

**HYDRAULIC CONDUCTIVITY TESTING MEASUREMENT**  
 (PERMOMETER)

Chamber Pressure (psi)	70	Influent Pressure (psi)	60	Effluent Pressure (psi)	60	B-Value	0.96			
Reset (Y/N)	Date	Clock Time	Elapsed Time	HA <sub>OUT</sub> (cm)	HA <sub>IN</sub> (cm)	Temp °C	Gradient	K (cm/sec)	Temp Correction	K <sub>20°C</sub> (cm/sec)
Y	12-22-17	8:51:52		7.5	1.88	21.0	10			
	12-22-17	8:53:21	0:01:29	5.5	1.96	21.0	6	2.2E-06	0.976	2.2E-06
	12-22-17	8:53:33	0:01:41	5.3	1.97	21.0	6	2.2E-06	0.976	2.2E-06
	12-22-17	8:53:52	0:02:00	5.0	1.98	21.0	6	2.2E-06	0.976	2.2E-06
	12-22-17	8:54:06	0:02:14	4.8	1.99	21.0	5	2.2E-06	0.976	2.2E-06

**HYDRAULIC CONDUCTIVITY (K<sub>20°C</sub>)      2.2E-06      cm/sec**



**HYDRAULIC CONDUCTIVITY TEST REPORT**  
 CONSTANT VOLUME APPARATUS (ASTM D 5084)

PROJECT: GREENPOINT LANDFILL  
 PROJECT NO.: J17-11684-02  
 DATE RECEIVED: 12-20-17

TESTED BY: JOHN MATHEW  
 CHECKED BY: PAUL YARBER

SAMPLE NO.	<u>PZ-22</u>	SAMPLE LOCATION:	<u>3.0-5.0'</u>
TYPE	<u>UNDISTURBED</u>	SAMPLE DESCRIPTION:	<u>BROWN SILTY FL-MED. SAND</u>

**SAMPLE DIMENSIONS AND PROPERTIES**

ITEM	INITIAL		FINAL	
	inches	centimeters	inches	centimeters
Sample Length	2.873	7.297	2.863	7.272
Sample Diameter	2.845	7.226	2.824	7.173
Length/Diameter Ratio		1.01		
Moisture Content (%)	WW= 200.2    DW= 180.2	11.1	WW= 198.0    DW= 158.0	25.3
Sample Wet Weight (grams)	513.8		574.5	
Wet Density (pcf)	107.2		122.0	
Dry Density (pcf)	96.5		97.4	
Saturation (%)	41		96	

**HYDRAULIC CONDUCTIVITY TESTING MEASUREMENT**  
 FALLING HEAD TEST

Confining Pressure (psi)		Influent Pressure (psi)		Effluent Pressure (psi)		B-Value								
90.2		80.2		80.0		0.95								
Date	Clock Time		Elapsed Time seconds	Pipet Readings				Head		Temp °C	Gradient	K (cm/sec)	Temp Correction	K <sub>20°C</sub> (cm/sec)
	Start	End		Initial		Final		Initial cm	Final cm					
12-28-17	10:47:00	10:47:12	12	1.0	23.0	3.0	21.0	40.092	35.360	21.0	5	8.0E-04	0.976	7.8E-04
12-28-17	10:47:12	10:47:25	13	3.0	21.0	5.0	19.0	35.360	30.629	21.0	5	8.4E-04	0.976	8.2E-04
12-28-17	10:47:25	10:47:40	15	5.0	19.0	7.0	17.0	30.629	25.897	21.0	5	8.5E-04	0.976	8.3E-04
12-28-17	10:47:40	10:47:58	18	7.0	17.0	9.0	15.0	25.897	21.165	21.0	5	8.5E-04	0.976	8.3E-04
				Pipet Length, cm		28.390	28.390							
				Pipet Volume, cc		24	24							
				Cross-sectional Area of Pipet, cm <sup>2</sup>		0.8454	0.8454							

**HYDRAULIC CONDUCTIVITY (K<sub>20°C</sub>)                      8.1E-04    cm/sec**

# LIQUID AND PLASTIC LIMITS TEST REPORT

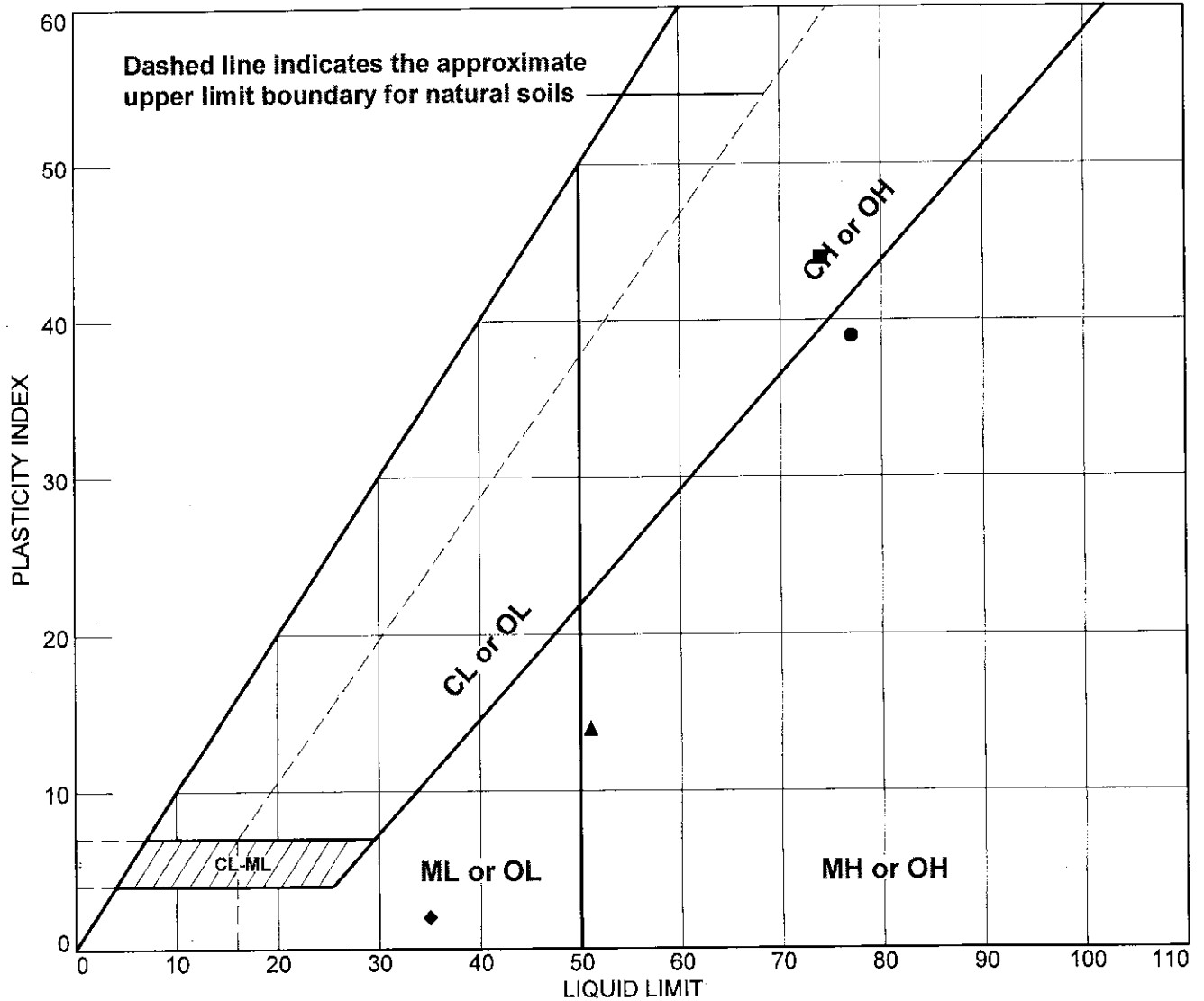

SOIL DATA								
SYMBOL	SOURCE	SAMPLE NO.	DEPTH	NATURAL WATER CONTENT (%)	PLASTIC LIMIT (%)	LIQUID LIMIT (%)	PLASTICITY INDEX (%)	USCS
●	Boring	PZ-16 A	2.0-4.0	37.4	38	77	39	MH
■	Boring	PZ-17 A	3.0-5.0	25.8	30	74	44	CH
▲	Boring	PZ-20 A	10.0-12.0	41.2	37	51	14	MH
◆	Boring	PZ-22 A	3.0-5.0	11.1	33	35	2	SM

**Bunnell Lammons Engineering, Inc.**

**Client:** Greenpoint Landfill, LLC

**Project:** Greenpoint Landfill

**Greenville, SC**

**Project No.:** 11684-02

**Figure**

**HYDRAULIC CONDUCTIVITY TEST REPORT**  
 CONSTANT VOLUME APPARATUS (ASTM D 5084)

PROJECT: GREENPOINT LANDFILL  
 PROJECT NO.: J17-11684-02  
 DATE RECEIVED: 1-3-19

TESTED BY: JOHN MATHEW  
 CHECKED BY: PAUL YARBER

SAMPLE NO. <u>PZ-16</u>	SAMPLE LOCATION: <u>1.5-4.0</u>
TYPE <u>UNDISTURBED</u>	SAMPLE DESCRIPTION: <u>GREY &amp; BROWN FL.-MED. SANDY CLAY</u>

**SAMPLE DIMENSIONS AND PROPERTIES**

ITEM	INITIAL		FINAL	
	inches	centimeters	inches	centimeters
Sample Length	2.984	7.579	2.988	7.590
Sample Diameter	2.841	7.216	2.834	7.198
Length/Diameter Ratio		1.05		
Moisture Content (%)	WW= 162.3 DW= 127.7	27.1	WW= 201.5 DW= 151.6	32.9
Sample Wet Weight (grams)	569.7		582.9	
Wet Density (pcf)	114.7		117.8	
Dry Density (pcf)	90.3		88.6	
Saturation (%)	86		101	

**HYDRAULIC CONDUCTIVITY TESTING MEASUREMENT**  
 (PERMOMETER)

Chamber Pressure (psi)	70	Influent Pressure (psi)	60	Effluent Pressure (psi)	60	B-Value	0.96			
Reset (Y/N)	Date	Clock Time	Elapsed Time	HA <sub>OUT</sub> (cm)	HA <sub>IN</sub> (cm)	Temp °C	Gradient	K (cm/sec)	Temp Correction	K <sub>20°C</sub> (cm/sec)
Y	1-7-19	2:42:07		5.0	2.19	23.0	5			
	1-7-19	2:42:28	0:00:21	4.0	2.23	23.0	3	9.9E-06	0.931	9.2E-06
	1-7-19	2:42:44	0:00:37	3.5	2.25	23.0	2	9.8E-06	0.931	9.1E-06
	1-7-19	2:43:09	0:01:02	3.0	2.27	23.0	2	9.8E-06	0.931	9.1E-06
	1-7-19	2:43:35	0:01:28	2.7	2.28	23.0	1	9.7E-06	0.931	9.1E-06

**HYDRAULIC CONDUCTIVITY (K<sub>20°C</sub>)      9.1E-06      cm/sec**

**HYDRAULIC CONDUCTIVITY TEST REPORT**  
 CONSTANT VOLUME APPARATUS (ASTM D 5084)

PROJECT: GREENPOINT LANDFILL  
 PROJECT NO.: J17-11684-02  
 DATE RECEIVED: 1-3-19

TESTED BY: JOHN MATHEW  
 CHECKED BY: PAUL YARBER

SAMPLE NO. <u>PZ-17</u>	SAMPLE LOCATION: <u>3.0-5.0</u>
TYPE <u>UNDISTURBED</u>	SAMPLE DESCRIPTION: <u>GREY &amp; BROWN FL.-MED. SANDY CLAY</u>

**SAMPLE DIMENSIONS AND PROPERTIES**

ITEM	INITIAL		FINAL	
	inches	centimeters	inches	centimeters
Sample Length	2.975	7.557	2.975	7.557
Sample Diameter	2.871	7.292	2.857	7.257
Length/Diameter Ratio		1.04		
Moisture Content (%)	WW= 167.0 DW= 131.4	27.1	WW= 217.5 DW= 169.7	28.2
Sample Wet Weight (grams)	609.1		619.0	
Wet Density (pcf)	120.5		123.6	
Dry Density (pcf)	94.8		96.5	
Saturation (%)	94		102	

**HYDRAULIC CONDUCTIVITY TESTING MEASUREMENT**  
 (PERMOMETER)

Chamber Pressure (psi)	70	Influent Pressure (psi)	60	Effluent Pressure (psi)	60	B-Value	0.96			
Reset (Y/N)	Date	Clock Time	Elapsed Time	HA <sub>OUT</sub> (cm)	HA <sub>IN</sub> (cm)	Temp °C	Gradient	K (cm/sec)	Temp Correction	K <sub>20°C</sub> (cm/sec)
Y	1-7-19	2:55:03		7.9	2.07	23.0	10			
	1-7-19	3:02:23	0:07:20	7.0	2.11	23.0	8	1.7E-07	0.931	1.6E-07
	1-7-19	3:03:23	0:08:20	6.9	2.11	23.0	8	1.7E-07	0.931	1.6E-07
	1-7-19	3:04:25	0:09:22	6.8	2.12	23.0	8	1.7E-07	0.931	1.6E-07
	1-7-19	3:05:24	0:10:21	6.7	2.12	23.0	8	1.7E-07	0.931	1.6E-07

**HYDRAULIC CONDUCTIVITY (K<sub>20°C</sub>)      1.6E-07      cm/sec**

**HYDRAULIC CONDUCTIVITY TEST REPORT**  
 CONSTANT VOLUME APPARATUS (ASTM D 5084)

PROJECT: GREENPOINT LANDFILL  
 PROJECT NO.: J17-11684-02  
 DATE RECEIVED: 1-3-19

TESTED BY: JOHN MATHEW  
 CHECKED BY: PAUL YARBER

SAMPLE NO. <u>PZ-20</u>	SAMPLE LOCATION: <u>10.0-12.0</u>
TYPE <u>UNDISTURBED</u>	SAMPLE DESCRIPTION: <u>YELLOWISH BROWN FL.-MED. SANDY ELSTIC SILT</u>

**SAMPLE DIMENSIONS AND PROPERTIES**

ITEM	INITIAL		FINAL	
	inches	centimeters	inches	centimeters
Sample Length	2.995	7.607	2.991	7.597
Sample Diameter	2.856	7.254	2.858	7.259
Length/Diameter Ratio		1.05		
Moisture Content (%)	WW= 168.6 DW= 120.6	39.8	WW= 227.9 DW= 161.4	41.2
Sample Wet Weight (grams)	541.2		556.7	
Wet Density (pcf)	107.5		110.5	
Dry Density (pcf)	76.9		78.3	
Saturation (%)	91		98	

**HYDRAULIC CONDUCTIVITY TESTING MEASUREMENT**  
 (PERMOMETER)

Chamber Pressure (psi)	70	Influent Pressure (psi)	60	Effluent Pressure (psi)	60	B-Value	0.96			
Reset (Y/N)	Date	Clock Time	Elapsed Time	HA <sub>OUT</sub> (cm)	HA <sub>IN</sub> (cm)	Temp °C	Gradient	K (cm/sec)	Temp Correction	K <sub>20°C</sub> (cm/sec)
Y	1-7-19	3:12:41		7.9	2.07	23.0	10			
	1-7-19	3:13:12	0:00:31	7.0	2.11	23.0	8	2.5E-06	0.931	2.3E-06
	1-7-19	3:13:33	0:00:52	6.5	2.13	23.0	8	2.4E-06	0.931	2.3E-06
	1-7-19	3:13:46	0:01:05	6.2	2.14	23.0	7	2.5E-06	0.931	2.3E-06
	1-7-19	3:14:24	0:01:43	5.5	2.17	23.0	6	2.4E-06	0.931	2.2E-06

**HYDRAULIC CONDUCTIVITY (K<sub>20°C</sub>)      2.3E-06      cm/sec**

**HYDRAULIC CONDUCTIVITY TEST REPORT**  
 CONSTANT VOLUME APPARATUS (ASTM D 5084)

PROJECT: GREENPOINT LANDFILL  
 PROJECT NO.: J17-11684-02  
 DATE RECEIVED: 1-3-19

TESTED BY: JOHN MATHEW  
 CHECKED BY: PAUL YARBER

SAMPLE NO. <u>PZ-22</u>	SAMPLE LOCATION: <u>3.5-5.5</u>
TYPE <u>UNDISTURBED</u>	SAMPLE DESCRIPTION: <u>BROWN SILTY FL.-MED. SAND</u>

**SAMPLE DIMENSIONS AND PROPERTIES**

ITEM	INITIAL		FINAL	
	inches	centimeters	inches	centimeters
Sample Length	2.923	7.424	2.837	7.206
Sample Diameter	2.839	7.211	2.835	7.201
Length/Diameter Ratio		1.03		
Moisture Content (%)	WW= 156.9    DW= 140.5	11.7	WW= 222.6    DW= 165.8	34.3
Sample Wet Weight (grams)	461.6		543.6	
Wet Density (pcf)	95.0		115.6	
Dry Density (pcf)	85.1		86.1	
Saturation (%)	32		96	

**HYDRAULIC CONDUCTIVITY TESTING MEASUREMENT**  
 FALLING HEAD TEST

Confining Pressure (psi) <u>70.2</u>		Influent Pressure (psi) <u>60.2</u>		Effluent Pressure (psi) <u>60.0</u>		B-Value <u>0.96</u>								
Date	Clock Time		Elapsed Time seconds	Pipet Readings				Head		Temp °C	Gradient	K (cm/sec)	Temp Correction	K <sub>20°C</sub> (cm/sec)
	Start	End		Initial		Final		Initial cm	Final cm					
1-14-19	11:35:20	11:35:27	7	1.0	23.0	3.0	21.0	40.092	35.361	21.0	5	1.3E-03	0.976	1.3E-03
1-14-19	11:35:27	11:35:35	8	3.0	21.0	5.0	19.0	35.361	30.629	21.0	5	1.3E-03	0.976	1.3E-03
1-14-19	11:35:35	11:35:44	9	5.0	19.0	7.0	17.0	30.629	25.897	21.0	5	1.4E-03	0.976	1.4E-03
1-14-19	11:35:44	11:35:55	11	7.0	17.0	9.0	15.0	25.897	21.166	21.0	5	1.4E-03	0.976	1.3E-03
			Pipet Length, cm	28.390	28.390									
			Pipet Volume, cc	24	24									
			Cross-sectional Area of Pipet, cm <sup>2</sup>	0.8454	0.8454									

**HYDRAULIC CONDUCTIVITY (K<sub>20°C</sub>)      1.3E-03    cm/sec**

# LIQUID AND PLASTIC LIMITS TEST REPORT

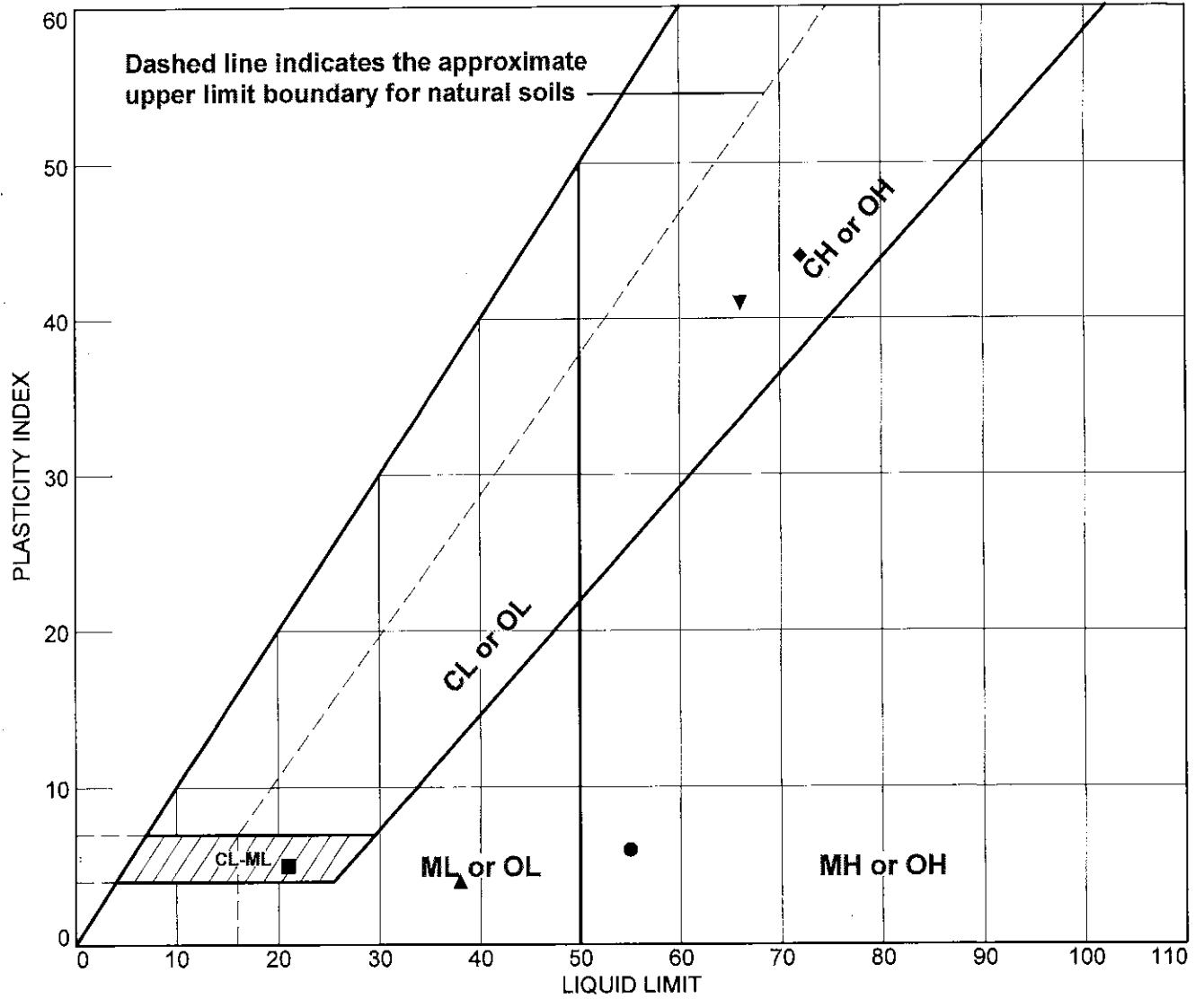

SOIL DATA								
SYMBOL	SOURCE	SAMPLE NO.	DEPTH	NATURAL WATER CONTENT (%)	PLASTIC LIMIT (%)	LIQUID LIMIT (%)	PLASTICITY INDEX (%)	USCS
●	Boring	PZ-14	1.0-2.5	53.3	49	55	6	SM
■	Boring	PZ-15	3.5-5.0	15.4	16	21	5	SC-SM
▲	Boring	PZ-15	18.5-20.0	18.5	34	38	4	SM
◆	Boring	PZ-16	1.5-4.0	27.1	28	72	44	CH
▼	Boring	PZ-17	3.0-5.0	27.1	25	66	41	CH

**Bunnell Lammons Engineering, Inc.**

**Client:** Greenpoint Landfill, LLC

**Project:** Greenpoint Landfill

**Greenville, SC**

**Project No.:** 11684-02

**Figure**

# LIQUID AND PLASTIC LIMITS TEST REPORT

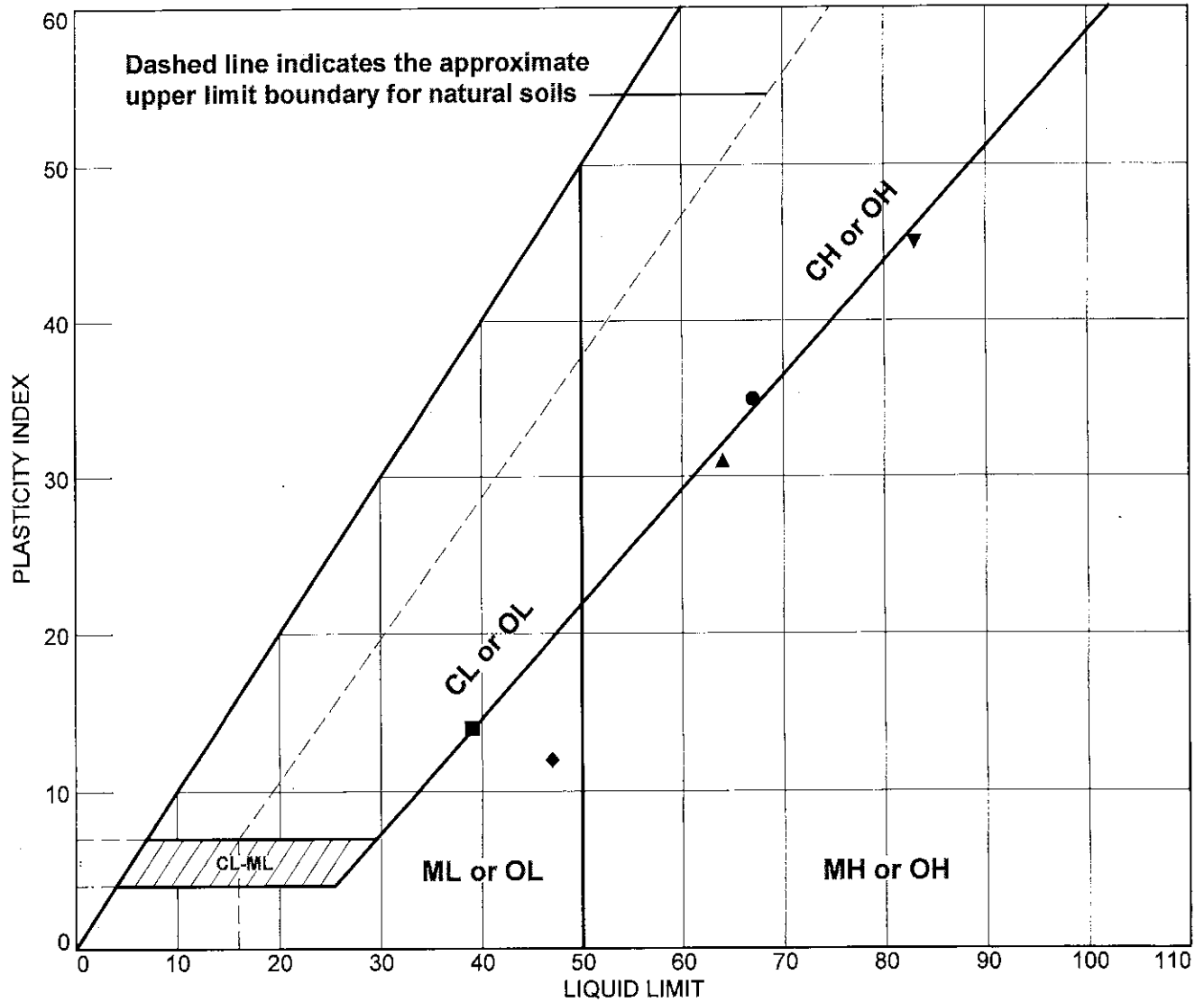

SOIL DATA								
SYMBOL	SOURCE	SAMPLE NO.	DEPTH	NATURAL WATER CONTENT (%)	PLASTIC LIMIT (%)	LIQUID LIMIT (%)	PLASTICITY INDEX (%)	USCS
●	Boring	PZ-18	6.0-7.5	26.5	32	67	35	CH
■	Boring	PZ-18	28.5-30.0	32.6	25	39	14	CL
▲	Boring	PZ-20	10.0-12.0	39.8	33	64	31	MH
◆	Boring	PZ-20	28.5-30.0	26.7	35	47	12	SM
▼	Boring	PZ-21	1.0-2.5	32.9	38	83	45	MH

**Bunnell Lammons Engineering, Inc.**

**Client:** Greenpoint Landfill, LLC

**Project:** Greenpoint Landfill

**Greenville, SC**

**Project No.:** 11684-02

**Figure**



# LIQUID AND PLASTIC LIMITS TEST REPORT

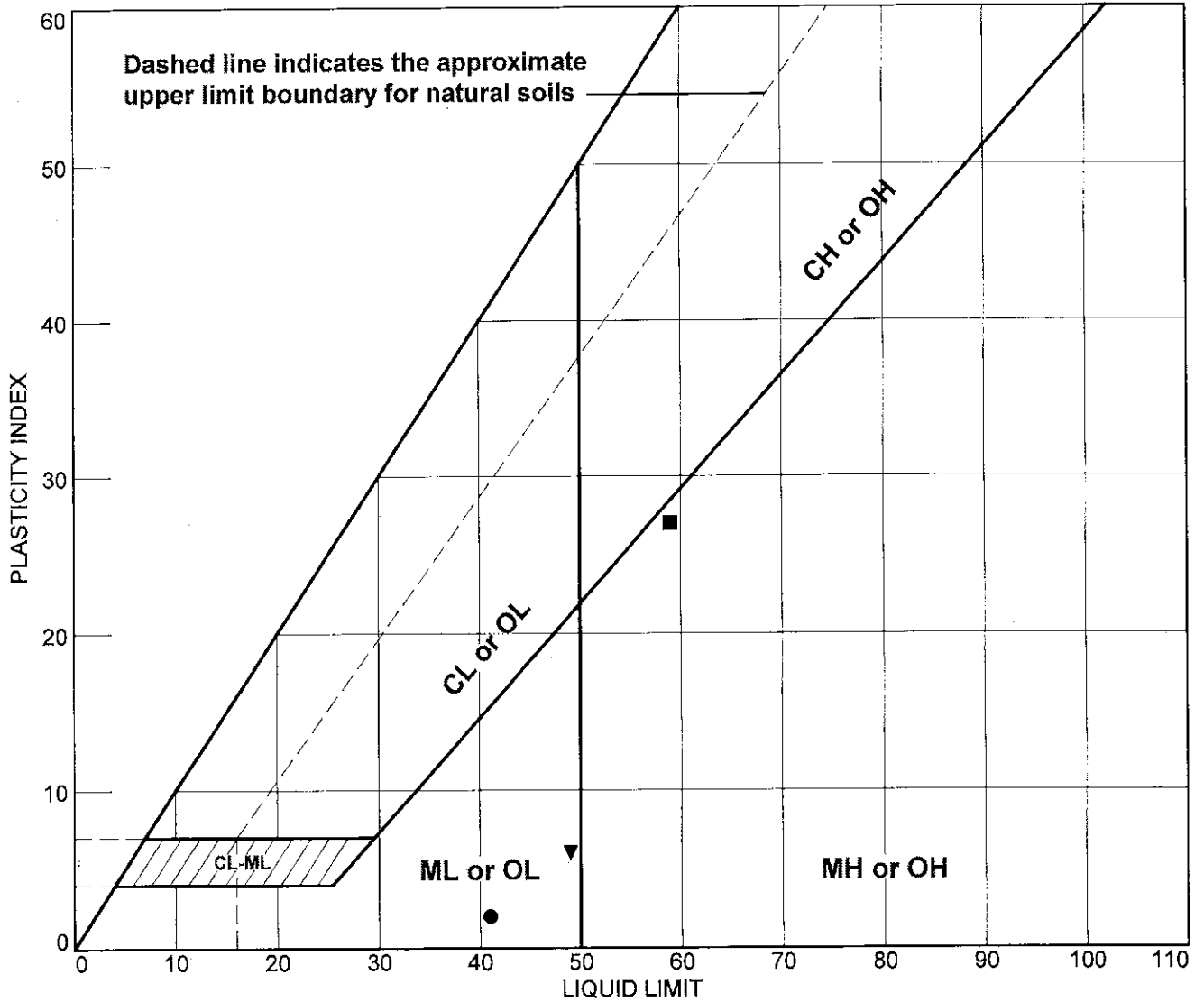

SOIL DATA								
SYMBOL	SOURCE	SAMPLE NO.	DEPTH	NATURAL WATER CONTENT (%)	PLASTIC LIMIT (%)	LIQUID LIMIT (%)	PLASTICITY INDEX (%)	USCS
●	Boring	PZ-22	3.5-5.5	11.5	39	41	2	SW-SM
■	Boring	PZ-23	6.0-7.5	25.8	32	59	27	SM
▲	Boring	PZ-24A	13.5-15.0	7.3	NP	NV	NP	SM
◆	Boring	PZ-24A	18.5-19.0	7.2	NP	28	NP	SM
▼	Boring	PZ-25	28.5-30.0	40.2	43	49	6	SM

**Bunnell Lammons Engineering, Inc.**  
 Greenville, SC

**Client:** Greenpoint Landfill, LLC  
**Project:** Greenpoint Landfill  
**Project No.:** 11684-02

**Figure**

# Particle Size Distribution Report

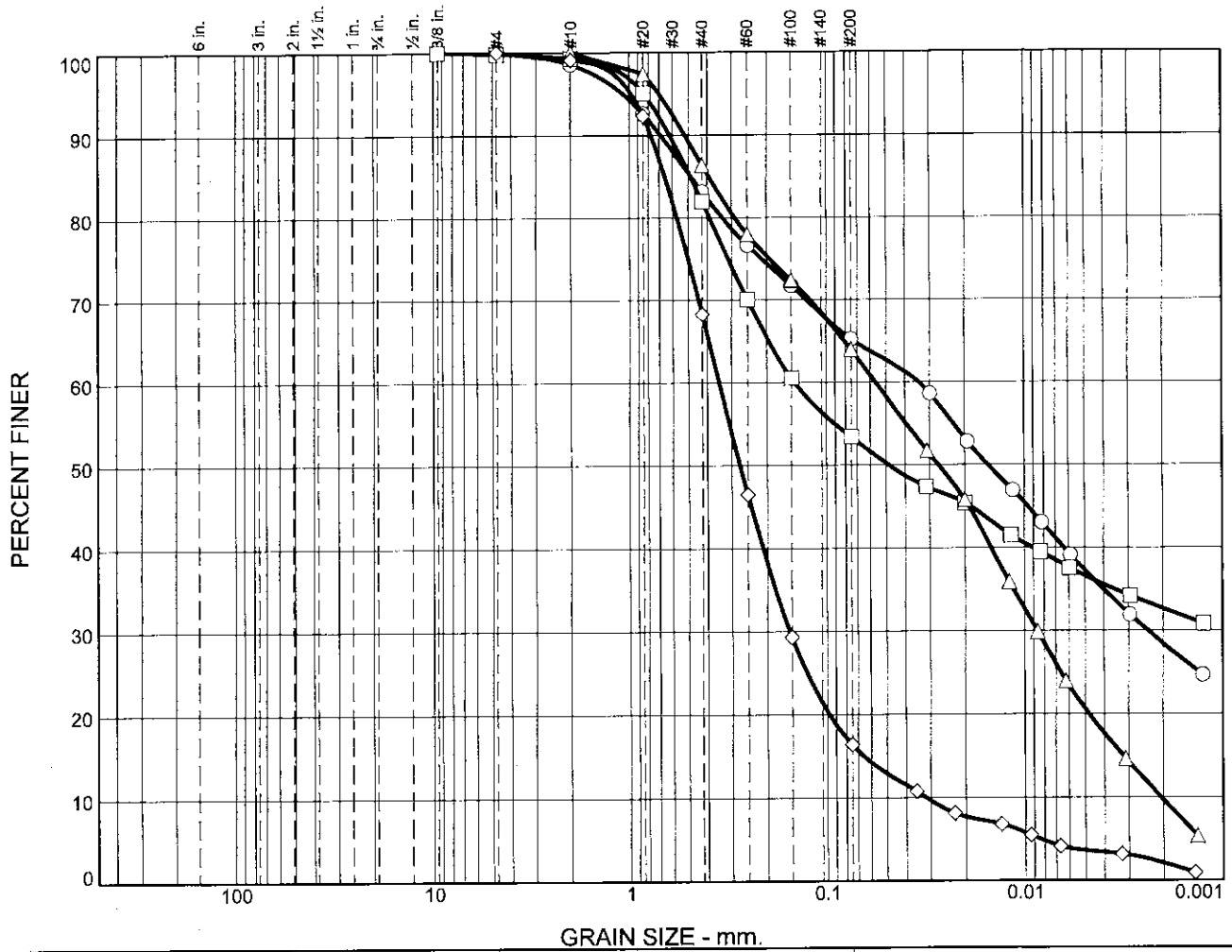

	% +3"	% Gravel		% Sand			% Fines	
		Coarse	Fine	Coarse	Medium	Fine	Silt	Clay
○	0.0	0.0	0.0	1.4	15.4	18.0	27.9	37.3
□	0.0	0.0	0.2	0.5	17.3	28.6	16.8	36.6
△	0.0	0.0	0.0	0.0	13.6	22.4	43.4	20.6
◇	0.0	0.0	0.0	0.9	30.8	51.9	12.8	3.6

SOIL DATA					
SYMBOL	SOURCE	SAMPLE NO.	DEPTH (ft.)	Material Description	USCS
○	Boring	PZ-16 A	2.0-4.0	Yellowish brown fi.-med. sandy elastic SILT	MH
□	Boring	PZ-17 A	3.0-5.0	Grey, yellow & brown fi.-med. sandy CLAY	CH
△	Boring	PZ-20 A	10.0-12.0	Yellow & brown fi.-med. sandy elastic SILT	MH
◇	Boring	PZ-22 A	3.0-5.0	Brown silty fi.-med. SAND	SM

# Particle Size Distribution Report

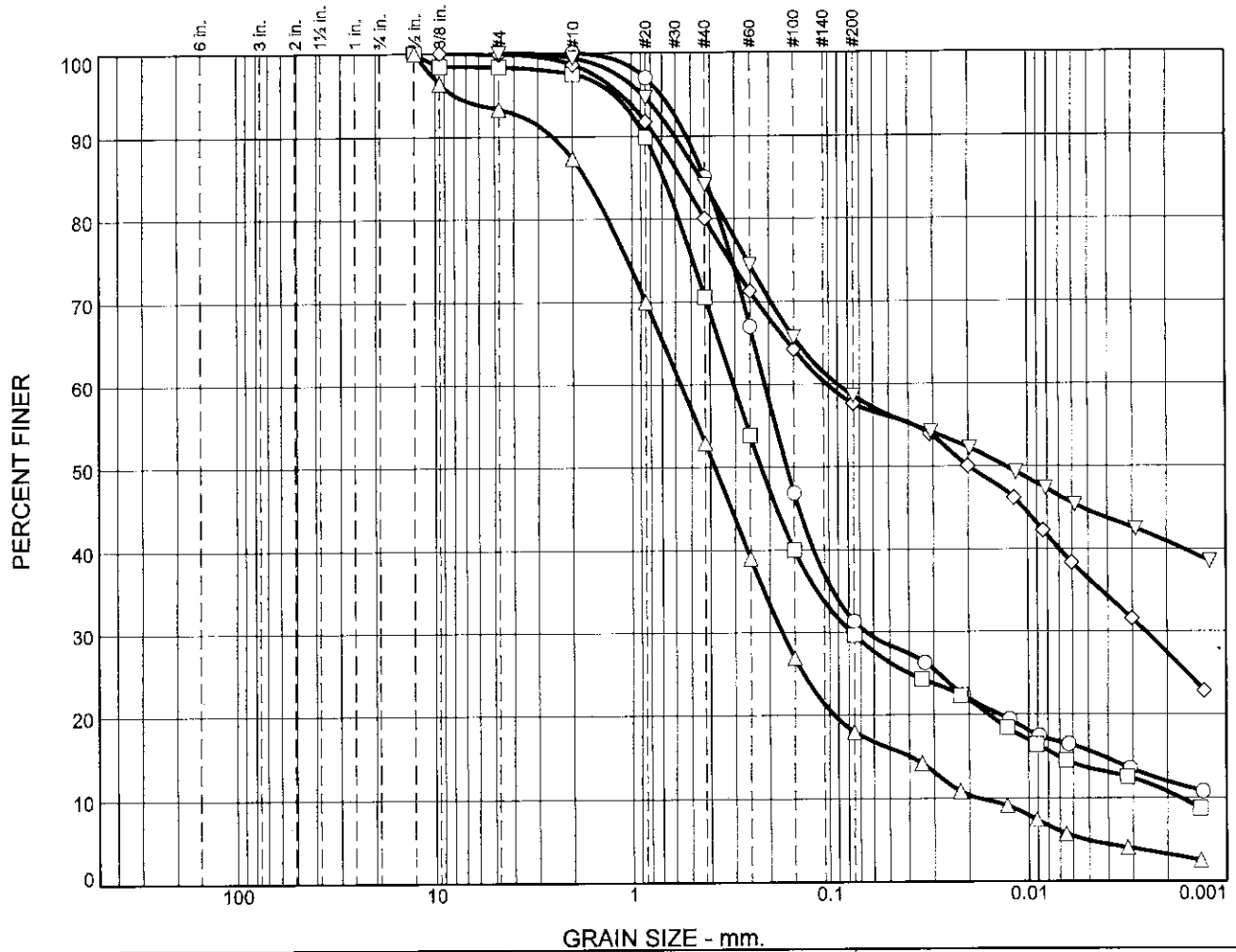

	% +3"	% Gravel		% Sand			% Fines	
		Coarse	Fine	Coarse	Medium	Fine	Silt	Clay
○	0.0	0.0	0.0	0.0	15.0	53.7	15.6	15.7
□	0.0	0.0	1.6	0.9	26.9	41.0	16.0	13.6
△	0.0	0.0	6.7	5.9	34.5	34.9	13.1	4.9
◇	0.0	0.0	0.2	1.2	18.5	22.5	21.2	36.4
▽	0.0	0.0	0.0	0.6	15.3	25.5	13.9	44.7

SOIL DATA					
SYMBOL	SOURCE	SAMPLE NO.	DEPTH (ft.)	Material Description	USCS
○	Boring	PZ-14	1.0-2.5	Dark brown silty fi.-med. SAND	SM
□	Boring	PZ-15	3.5-5.0	Brown & grey silty clayey fi.-med. SAND	SC-SM
△	Boring	PZ-15	18.5-20.0	Grey silty fi.-co. SAND	SM
◇	Boring	PZ-16	1.5-4.0	Grey & brown fi.-med. sandy CLAY	CH
▽	Boring	PZ-17	3.0-5.0	Grey & brown fi.-med. sandy CLAY	CH

# Particle Size Distribution Report

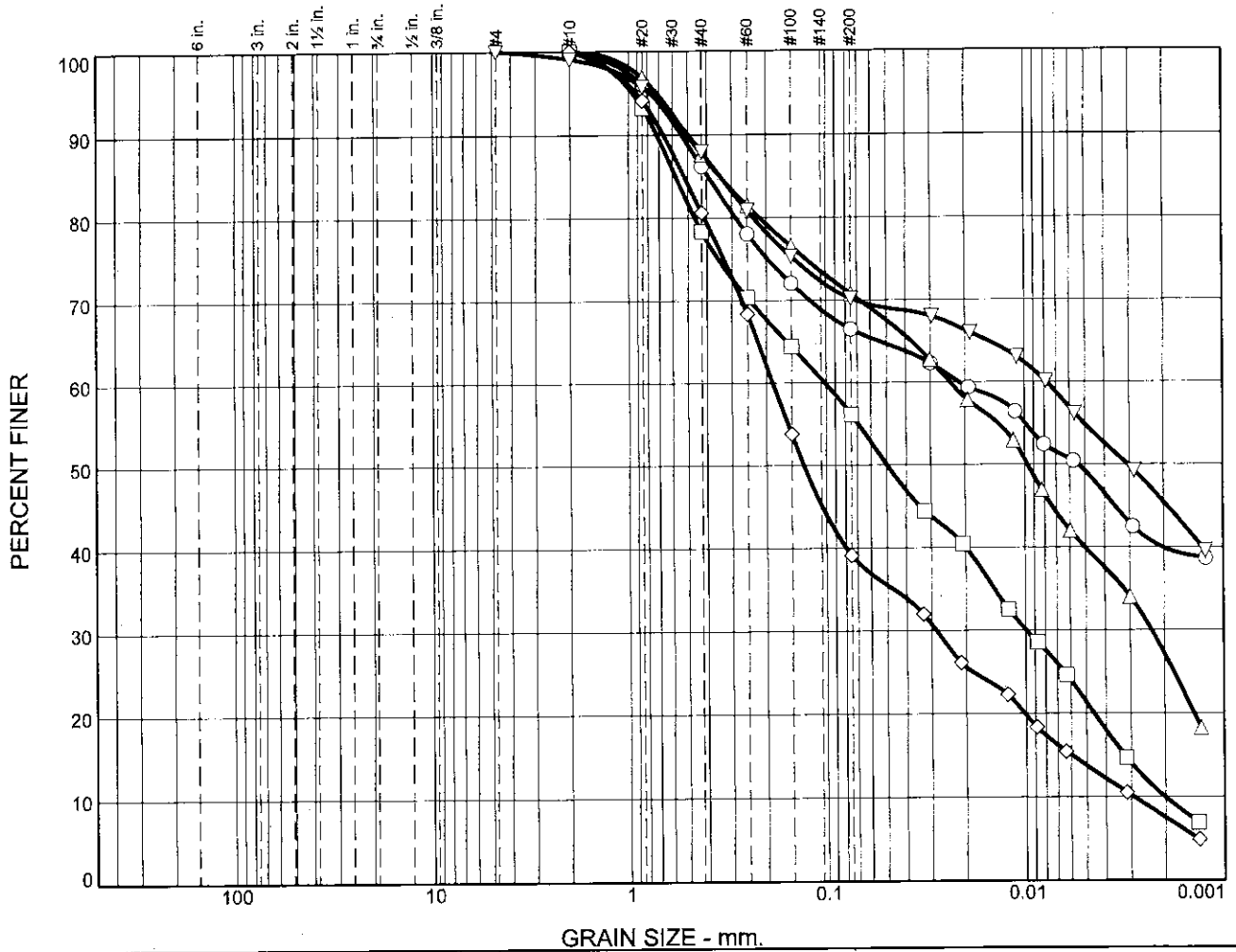

	% +3"	% Gravel		% Sand			% Fines	
		Coarse	Fine	Coarse	Medium	Fine	Silt	Clay
○	0.0	0.0	0.0	0.0	13.7	19.8	17.3	49.2
□	0.0	0.0	0.0	0.0	21.6	22.3	34.8	21.3
△	0.0	0.0	0.0	0.0	12.3	16.9	30.8	40.0
◇	0.0	0.0	0.0	0.0	19.4	41.4	25.5	13.7
▽	0.0	0.0	0.0	1.0	11.0	17.8	15.4	54.8

SOIL DATA					
SYMBOL	SOURCE	SAMPLE NO.	DEPTH (ft.)	Material Description	USCS
○	Boring	PZ-18	6.0-7.5	Reddish brown fi.-med. sandy CLAY	CH
□	Boring	PZ-18	28.5-30.0	Light brown fi.-med. sandy CLAY	CL
△	Boring	PZ-20	10.0-12.0	Yellowish brown fi.-med. sandy elastic SILT	MH
◇	Boring	PZ-20	28.5-30.0	White & brown silty fi.-med. SAND	SM
▽	Boring	PZ-21	1.0-2.5	Light grey & brown fi.-med. sandy elastic SILT	MH

**Bunnell Lammons Engineering, Inc.**  
Greenville, SC

**Client:** Greenpoint Landfill, LLC  
**Project:** Greenpoint Landfill  
**Project No.:** 11684-02

**Figure**

# Particle Size Distribution Report

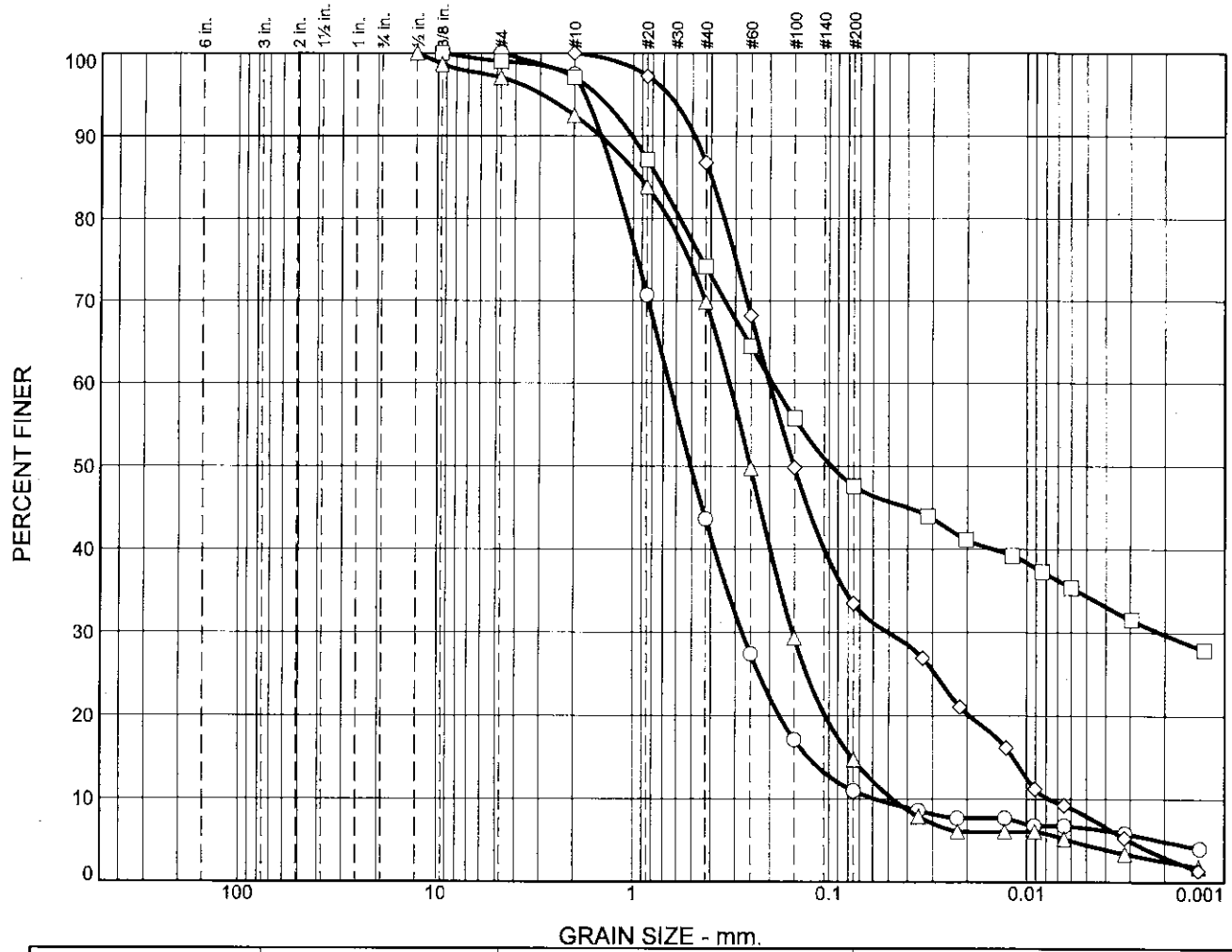

	% +3"	% Gravel		% Sand			% Fines	
		Coarse	Fine	Coarse	Medium	Fine	Silt	Clay
○	0.0	0.0	0.0	2.5	53.8	32.7	4.5	6.5
□	0.0	0.0	1.0	1.9	22.9	26.6	13.2	34.4
△	0.0	0.0	3.0	4.5	22.6	55.2	10.2	4.5
◇	0.0	0.0	0.0	0.0	13.2	53.3	25.5	8.0

SOIL DATA					
SYMBOL	SOURCE	SAMPLE NO.	DEPTH (ft.)	Material Description	USCS
○	Boring	PZ-22	3.5-5.5	Brown silty fi.-med. SAND	SW-SM
□	Boring	PZ-23	6.0-7.5	Reddish brown silty fi.-med. SAND	SM
△	Boring	PZ-24	13.5-14.0	Grey silty fi.-med. SAND	SM
◇	Boring	PZ-25	28.5-30.0	Dark brown silty fi.-med. SAND	SM

APPENDIX E  
Historical Precipitation Data Summary

**TABLE E**  
**MONTHLY PRECIPITATION DATA 2013 TO 2018**  
**Greenpointe Class II Landfill Expansion**  
**Anderson County, South Carolina**  
**BLE Project Number J18-11684-02**

MONTH	Year						Monthly Avg.
	2013	2014	2015	2016	2017	2018	
January	7.31	3.13	1.71	2.3	3.55	3.19	3.53
February	4.01	3.15	4.29	4.27	1.61	5.05	3.73
March	3.4	3.75	2.7	1.1	3.26	4.29	3.08
April	4.83	2.21	2.57	2.57	6.63	5.41	4.04
May	5.49	2.51	4.11	2.98	4.01	3.88	3.83
June	6.7	5.14	4.28	1.98	2.59	4.04	4.12
July	8.71	2.09	1.83	2.75	0.62	1.95	2.99
August	5.39	4.03	4.6	4.52	5.35	0.71	4.10
September	3.22	1.9	4.23	0.04	2.97	3.66	2.67
October	2.07	2.75	3.04	0	3.39	4.52	2.63
November	3.24	4.69	6.86	0.91	0.24	8.56	4.08
December	5.01	2.89	3.48	1.89	1.86	5.5	3.44
SEASON							Seasonal Avg.
Winter	<b>14.72</b>	10.03	8.7	7.67	8.42	12.53	10.35
Spring	<b>17.02</b>	9.86	10.96	7.53	13.23	13.33	11.99
Summer	<b>17.32</b>	8.02	10.66	7.31	8.94	6.32	9.76
Fall	10.32	10.33	13.38	2.8	5.49	<b>18.58</b>	10.15
YEAR							Yearly Avg.
Yearly Totals	59.38	38.24	43.70	25.31	36.08	50.76	42.25

**Notes:**

1. Data Source: NOAA, public information
2. Data updated through December 2018

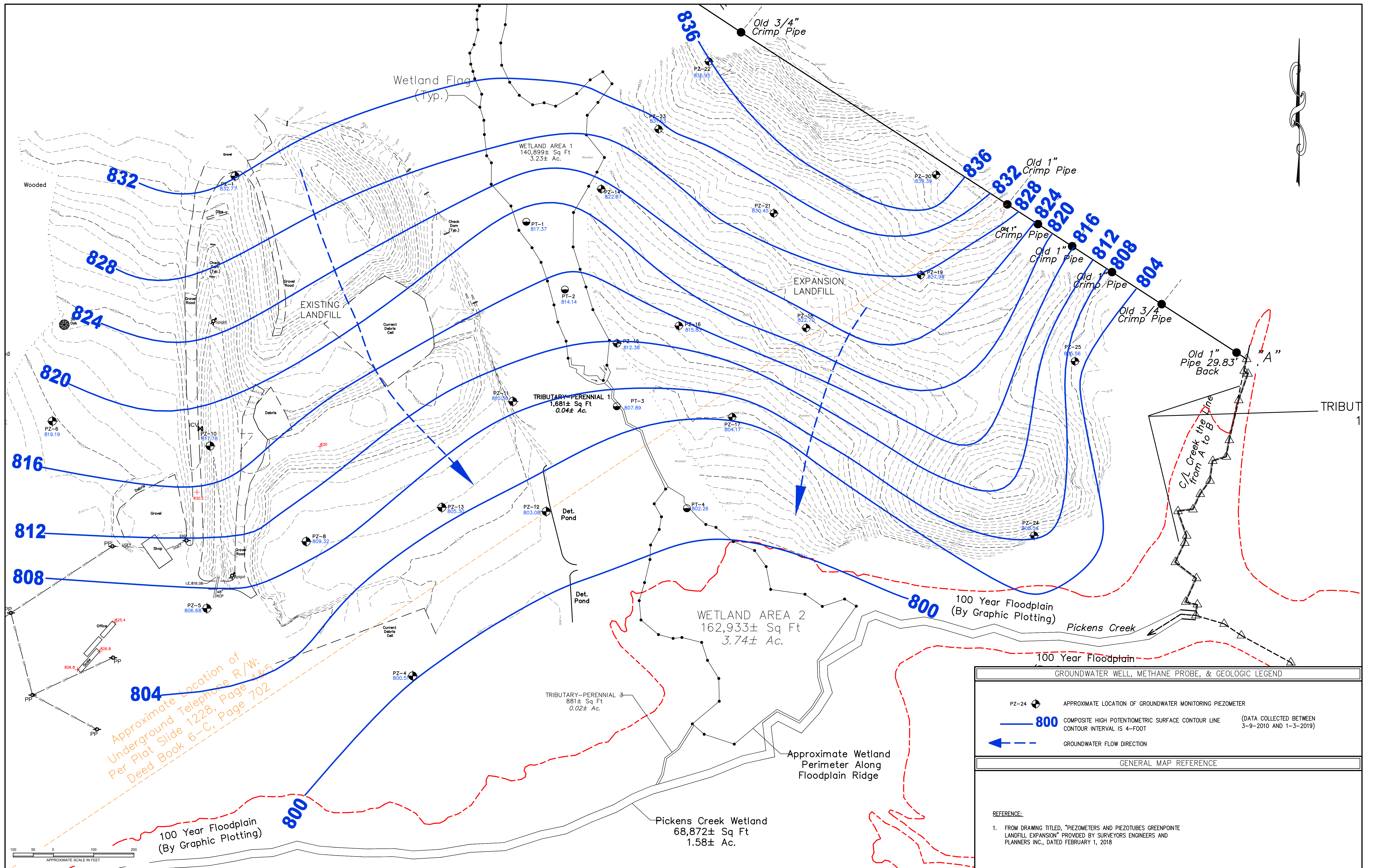

No.	REVISIONS DESCRIPTION	BY

<b>DRAWN:</b> IAI	<b>DATE:</b> 4-22-19
<b>CHECKED:</b> DPO	<b>CAD FILE:</b> GREENPOINTE-02WIMFIG4
<b>APPROVED:</b>	<b>JOB NO:</b> J18-11684-02

**BLE** **BUNNELL LAMMONS ENGINEERING**

6004 Ponders Court, Greenville, SC 29615  
Phone: (864) 288-1265 Fax: (864) 288-4430

COMPOSITE HIGH GROUNDWATER POTENTIOMETRIC SURFACE MAP  
GREENPOINTE CLASS II LANDFILL  
ANDERSON COUNTY, SOUTH CAROLINA



# KEY TO SOIL CLASSIFICATIONS AND CONSISTENCY DESCRIPTIONS

BUNNELL-LAMMONS ENGINEERING, INC.  
GREENVILLE, SOUTH CAROLINA

## Penetration Resistance\* Blows per Foot

SANDS  
0 to 4  
5 to 10  
11 to 20  
21 to 30  
31 to 50  
over 50

## Relative Density

Very Loose  
Loose  
Firm  
Very Firm  
Dense  
Very Dense

## Particle Size Identification

Boulder: Greater than 300 mm  
Cobble: 75 to 300 mm  
Gravel:  
Coarse - 19 to 75 mm  
Fine - 4.75 to 19 mm  
Sand:  
Coarse - 2 to 4.75 mm  
Medium - 0.425 to 2 mm  
Fine - 0.075 to 0.425 mm  
Silt & Clay: Less than 0.075 mm

## Penetration Resistance\* Blows per Foot

SILTS and CLAYS  
0 to 2  
3 to 4  
5 to 8  
9 to 15  
16 to 30  
31 to 50  
over 50

## Consistency

Very Soft  
Soft  
Firm  
Stiff  
Very Stiff  
Hard  
Very Hard

\*ASTM D 1586

## KEY TO DRILLING SYMBOLS



Grab Sample



Split Spoon Sample



Undisturbed Sample

NR = No reaction to HCL

NA = Not applicable

NS = No sample



Groundwater Table at Time of Drilling



Groundwater Table 24 Hours after Completion of Drilling

## KEY TO SOIL CLASSIFICATIONS



Well-graded Gravel  
GW

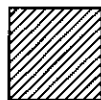

Low Plasticity Clay  
CL



Clayey Silt  
MH

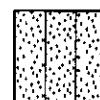

Silty Sand  
SM



Poorly-graded Gravel  
GP



Sandy Clay  
CLS

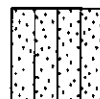

Sandy Silt  
MLS



Topsoil  
TOPSOIL



Partially Weathered Rock  
BLDRCBBL

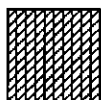

Silty Clay  
CL-ML

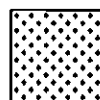

Sand  
SW

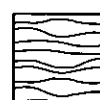

Liquid Sludge  
SLUDGE

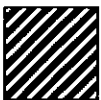

High Plasticity Clay  
CH



Silt  
ML

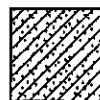

Clayey Sand  
SC



Fill  
FILL

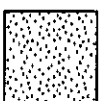

Poorly Graded Sand  
SP

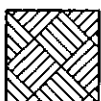

Bedrock  
BEDROCK

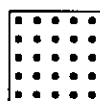

Waste  
WOOD



**BUNNELL-LAMMONS  
ENGINEERING, INC.**  
GEOTECHNICAL AND ENVIRONMENTAL  
CONSULTANTS

**GROUNDWATER MONITORING WELL NO. PZ-14**

PROJECT: Greenpointe Class 2 Landfill

PROJECT NO.: J17-11684-02

CLIENT: Greenpointe Landfill, LLC

START: 12-4-17 END: 12-4-17

LOCATION: Easley, South Carolina

ELEVATION: 822.99

DRILLER: Landprobe, R. Banks

LOGGED BY: R. Doherty

DRILLING METHOD: CME 750; 4-1/4 inch hollow stem auger

DEPTH TO - WATER> INITIAL: ▽ 1.5 AFTER 24 HOURS: ▽ 1.5 CAVING: ☒

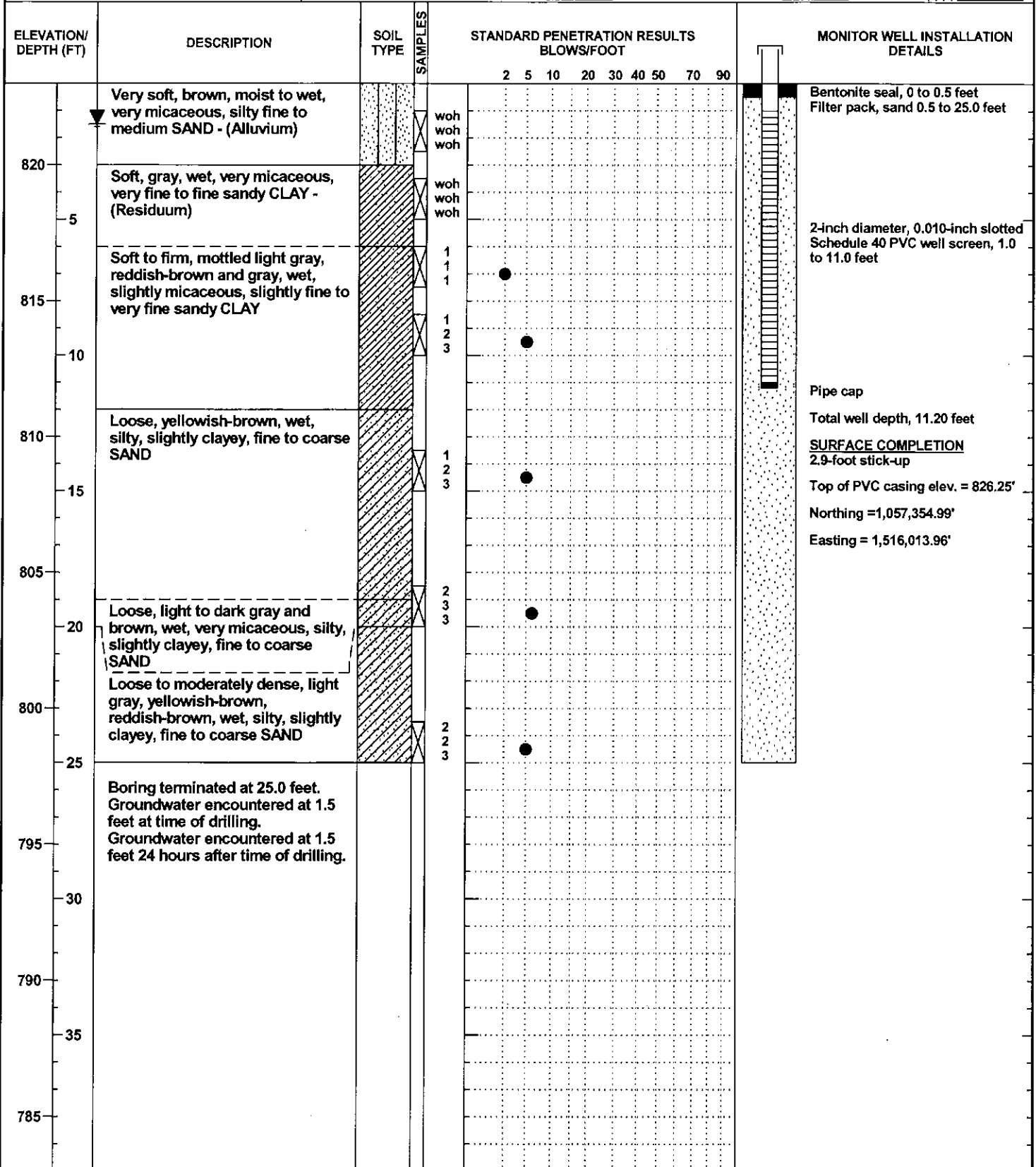

GEOI WELL 11684-02.GPJ 5/14/19



**BUNNELL-LAMMONS  
ENGINEERING, INC.**  
GEOTECHNICAL AND ENVIRONMENTAL  
CONSULTANTS

**GROUNDWATER MONITORING WELL NO. PZ-15**

PROJECT: Greenpointe Class 2 Landfill

PROJECT NO.: J17-11684-02

CLIENT: Greenpointe Landfill, LLC

START: 12-5-17 END: 12-5-17

LOCATION: Easley, South Carolina

ELEVATION: 813.03

DRILLER: Landprobe, R. Banks

LOGGED BY: R. Doherty

DRILLING METHOD: CME 750; 4-1/4 inch hollow stem auger

DEPTH TO - WATER> INITIAL: ▽ 2.7 AFTER 24 HOURS: ▽ 2.11 CAVING >

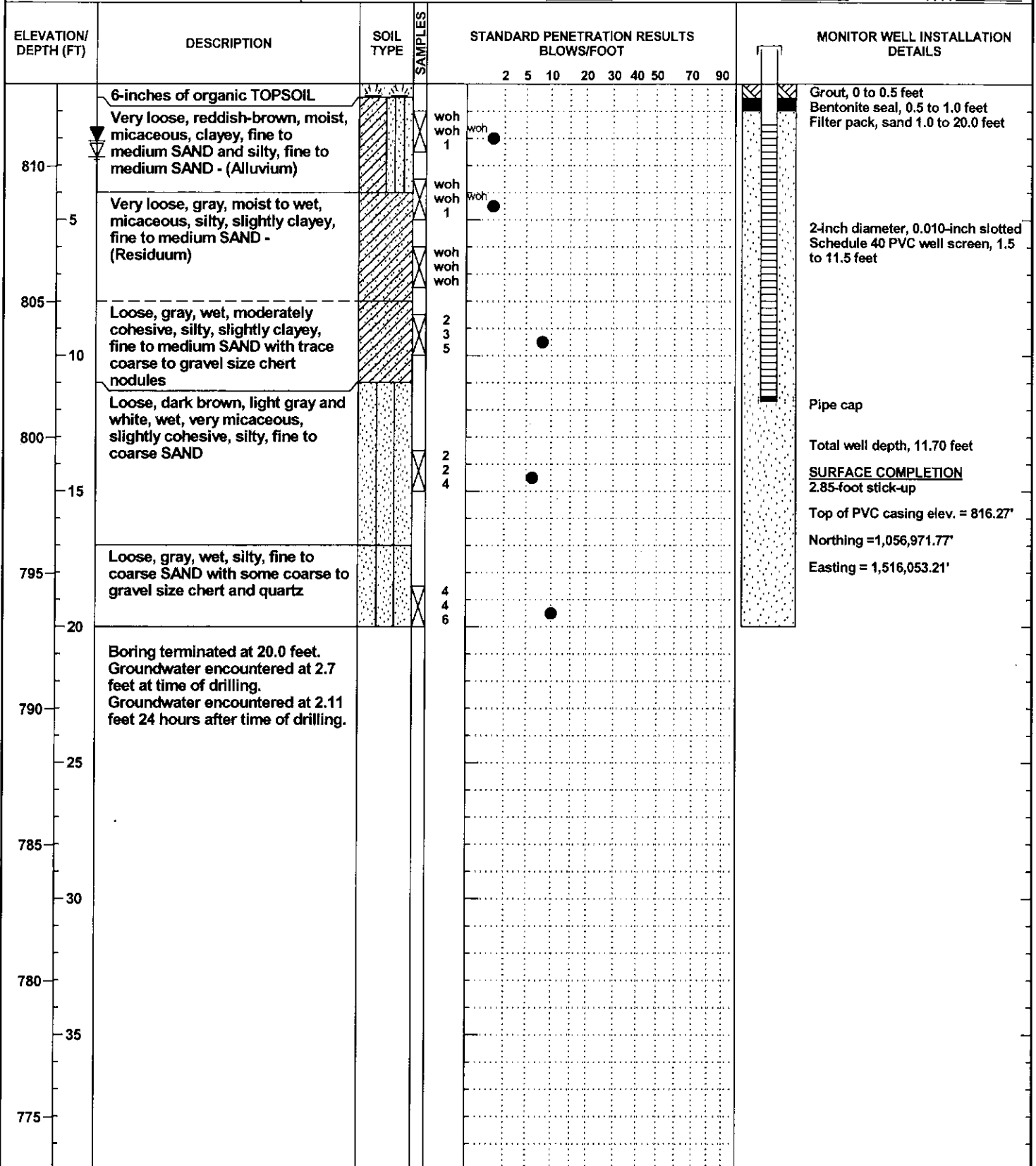



**BUNNELL-LAMMONS  
ENGINEERING, INC.**  
GEOTECHNICAL AND ENVIRONMENTAL  
CONSULTANTS

**GROUNDWATER MONITORING WELL NO. PZ-16**

PROJECT: Greenpointe Class 2 Landfill

PROJECT NO.: J17-11684-02

CLIENT: Greenpointe Landfill, LLC

START: 12-5-17 END: 12-5-17

LOCATION: Easley, South Carolina

ELEVATION: 816.24

DRILLER: Landprobe, R. Banks

LOGGED BY: R. Doherty

DRILLING METHOD: CME 750; 4-1/4 inch hollow stem auger

DEPTH TO - WATER> INITIAL: ▽ 8.2 AFTER 24 HOURS: ▽ 1.5 CAVING: ▣

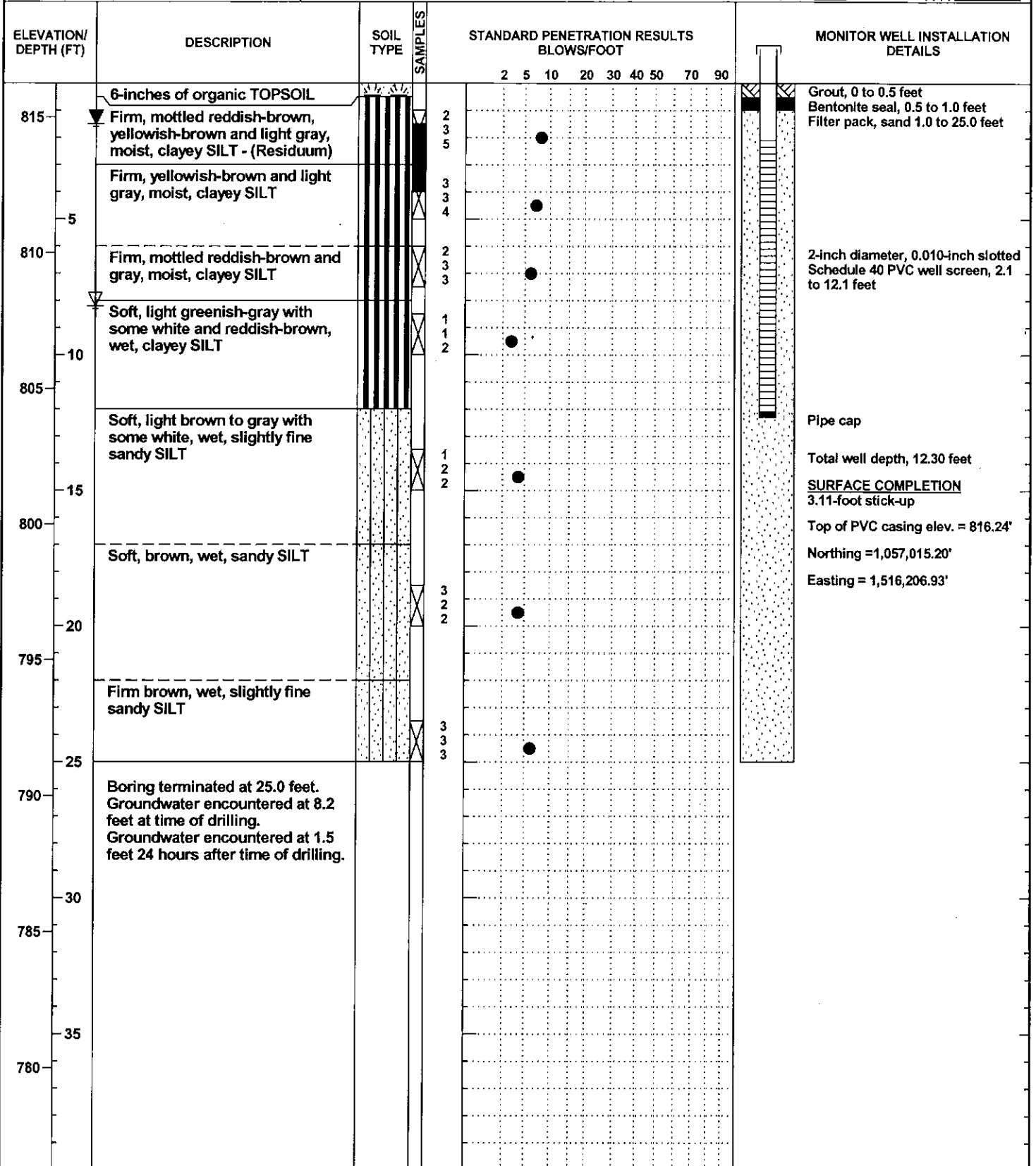



**BUNNELL-LAMMONS  
ENGINEERING, INC.**  
GEOTECHNICAL AND ENVIRONMENTAL  
CONSULTANTS

## GROUNDWATER MONITORING WELL NO. PZ-17

PROJECT: <u>Greenpointe Class 2 Landfill</u>	PROJECT NO.: <u>J17-11684-02</u>
CLIENT: <u>Greenpointe Landfill, LLC</u>	START: <u>12-5-17</u> END: <u>12-5-17</u>
LOCATION: <u>Easley, South Carolina</u>	ELEVATION: <u>809.76</u>
DRILLER: <u>Landprobe, R. Banks</u>	LOGGED BY: <u>R. Doherty</u>
DRILLING METHOD: <u>CME 750; 4-1/4 inch hollow stem auger</u>	
DEPTH TO - WATER> INITIAL: $\nabla$ <u>10.14</u> AFTER 24 HOURS: $\nabla$ <u>8.0</u> CAVING >	

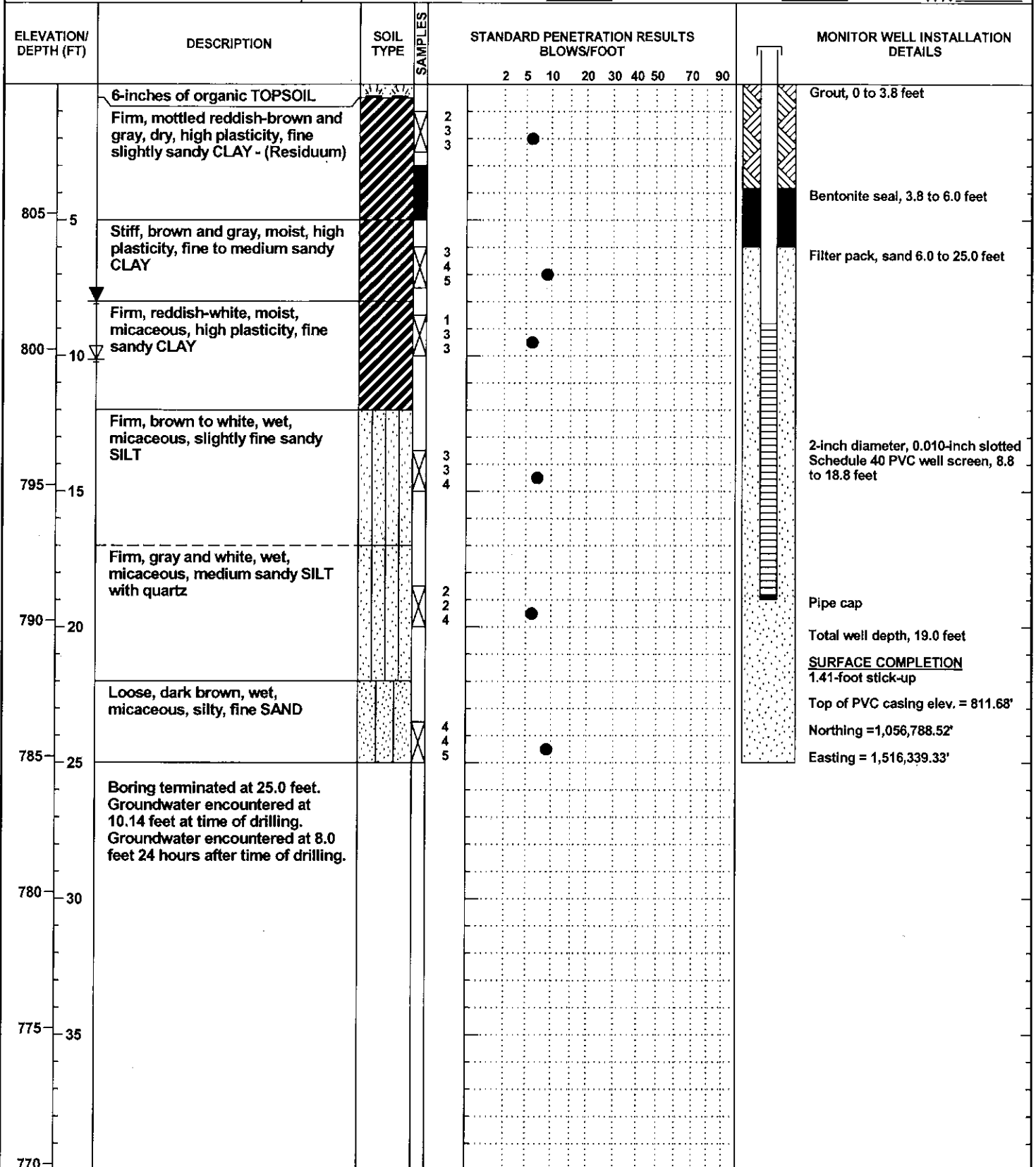

GEOT\_WELL\_11684-02.GPJ 5/14/19



# GROUNDWATER MONITORING WELL NO. PZ-18

**BUNNELL-LAMMONS  
ENGINEERING, INC.**  
GEOTECHNICAL AND ENVIRONMENTAL  
CONSULTANTS

PROJECT: Greenpointe Class 2 Landfill

PROJECT NO.: J17-11684-02

CLIENT: Greenpointe Landfill, LLC

START: 12-5-17 END: 12-5-17

LOCATION: Easley, South Carolina

ELEVATION: 824.02

DRILLER: Landprobe, R. Banks

LOGGED BY: R. Doherty

DRILLING METHOD: CME 750; 4-1/4 inch hollow stem auger

DEPTH TO - WATER> INITIAL:  $\nabla$  10.2 AFTER 24 HOURS:  $\nabla$  5.8 CAVING  $\gg$

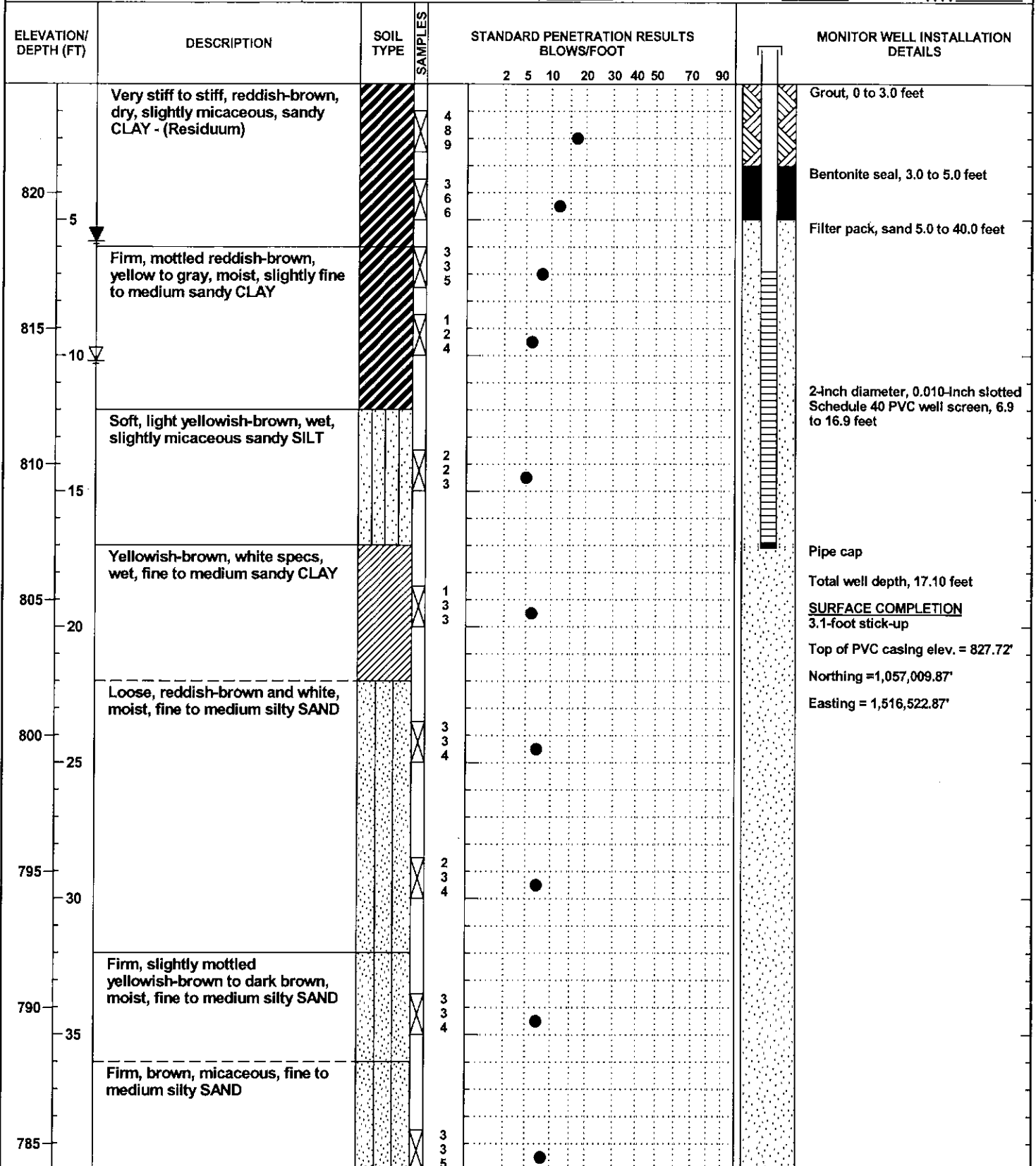

GROUNDWATER MONITORING WELL NO. PZ-18

Sheet 1 of 2

GEOT. WELL 11684-02.GPJ 5/14/19



**BUNNELL-LAMMONS  
ENGINEERING, INC.**  
GEOTECHNICAL AND ENVIRONMENTAL  
CONSULTANTS

**GROUNDWATER MONITORING WELL NO. PZ-18**

PROJECT: Greenpointe Class 2 Landfill

PROJECT NO.: J17-11684-02

CLIENT: Greenpointe Landfill, LLC

START: 12-5-17 END: 12-5-17

LOCATION: Easley, South Carolina

ELEVATION: 824.02

DRILLER: Landprobe, R. Banks

LOGGED BY: R. Doherty

DRILLING METHOD: CME 750; 4-1/4 inch hollow stem auger

DEPTH TO - WATER> INITIAL: ▽ 10.2 AFTER 24 HOURS: ▽ 5.8 CAVING> ☒

ELEVATION/ DEPTH (FT)	DESCRIPTION	SOIL TYPE	SAMPLES	STANDARD PENETRATION RESULTS BLOWS/FOOT								MONITOR WELL INSTALLATION DETAILS									
				2	5	10	20	30	40	50	70		90								
780	Boring terminated at 40.0 feet. Groundwater encountered at 10.2 feet at time of drilling. Groundwater encountered at 5.8 feet 24 hours after time of drilling.																				
775																					
770																					
765																					
760																					
755																					
750																					
745																					

GEOI\_WELL\_11684-02.GPJ 5/14/19



**BUNNELL-LAMMONS  
ENGINEERING, INC.**  
GEOTECHNICAL AND ENVIRONMENTAL  
CONSULTANTS

**GROUNDWATER MONITORING WELL NO. PZ-19**

PROJECT: Greenpointe Class 2 Landfill

PROJECT NO.: J17-11684-02

CLIENT: Greenpointe Landfill, LLC

START: 12-6-17 END: 12-6-17

LOCATION: Easley, South Carolina

ELEVATION: 837.05

DRILLER: Landprobe, R. Banks

LOGGED BY: R. Doherty

DRILLING METHOD: CME 750; 4-1/4 inch hollow stem auger

DEPTH TO - WATER> INITIAL:  $\nabla$  15.25 AFTER 24 HOURS:  $\nabla$  28.16 CAVING:  $\otimes$

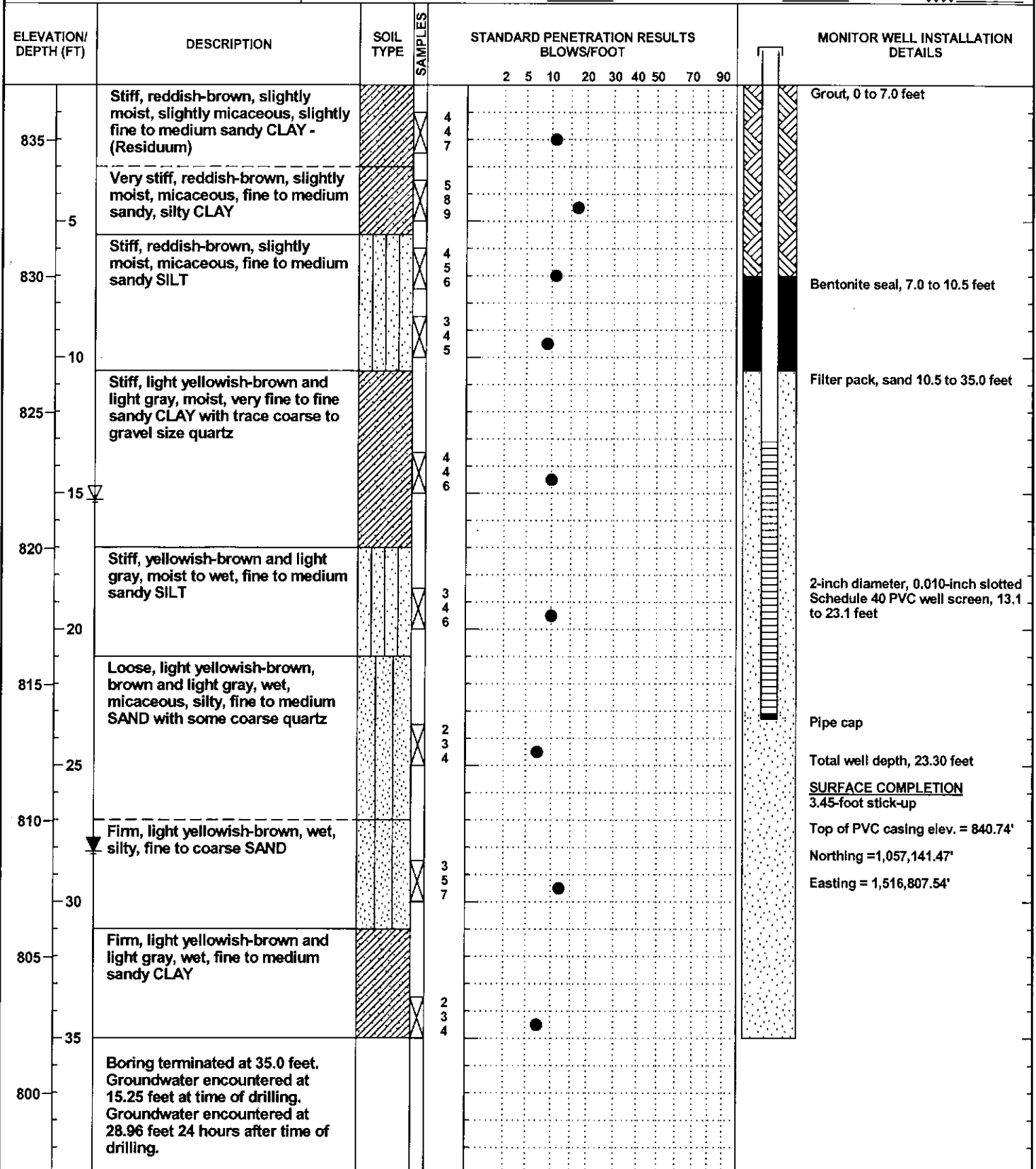

GEO. WELL 11684-02.GPJ 5/14/19





**BUNNELL-LAMMONS  
ENGINEERING, INC.**  
GEOTECHNICAL AND ENVIRONMENTAL  
CONSULTANTS

**GROUNDWATER MONITORING WELL NO. PZ-20**

PROJECT: Greenpointe Class 2 Landfill

PROJECT NO.: J17-11684-02

CLIENT: Greenpointe Landfill, LLC

START: 12-6-17 END: 12-18-17

LOCATION: Easley, South Carolina

ELEVATION: 847.19

DRILLER: Landprobe, R. Banks

LOGGED BY: R. Doherty

DRILLING METHOD: CME 750; 4-1/4 inch hollow stem auger

DEPTH TO - WATER> INITIAL:  $\nabla$  17.70 AFTER 24 HOURS:  $\nabla$  20.11 CAVING:

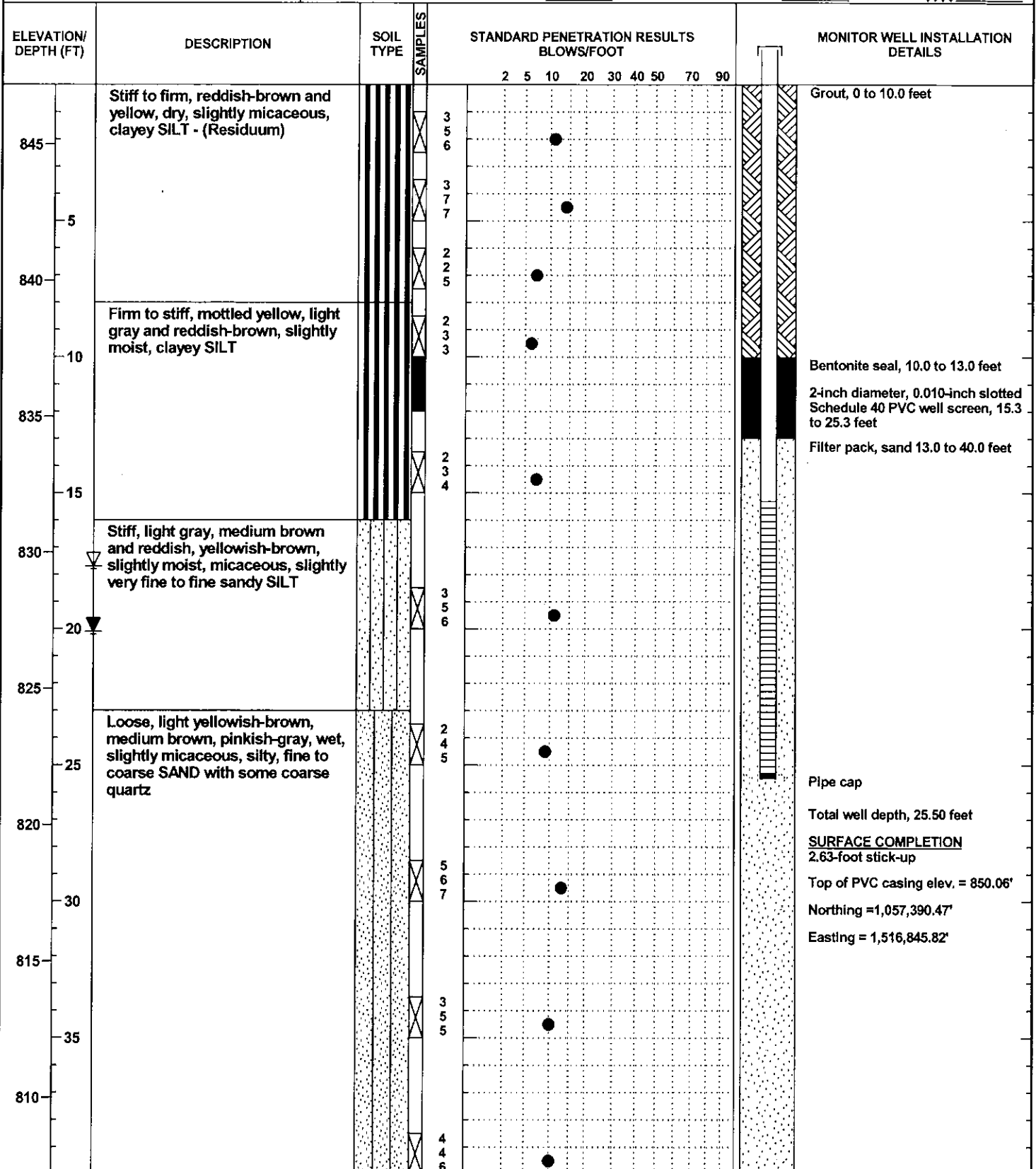

GEOI\_WELL\_11684-02.GPJ 5/14/19



**BUNNELL-LAMMONS  
ENGINEERING, INC.**  
GEOTECHNICAL AND ENVIRONMENTAL  
CONSULTANTS

**GROUNDWATER MONITORING WELL NO. PZ-20**

PROJECT: Greenpointe Class 2 Landfill PROJECT NO.: J17-11684-02  
 CLIENT: Greenpointe Landfill, LLC START: 12-6-17 END: 12-18-17  
 LOCATION: Easley, South Carolina ELEVATION: 847.19  
 DRILLER: Landprobe, R. Banks LOGGED BY: R. Doherty  
 DRILLING METHOD: CME 750; 4-1/4 inch hollow stem auger  
 DEPTH TO - WATER> INITIAL: ▽ 17.70 AFTER 24 HOURS: ▽ 20.11 CAVING> ☒

ELEVATION/ DEPTH (FT)	DESCRIPTION	SOIL TYPE	SAMPLES	STANDARD PENETRATION RESULTS BLOWS/FOOT								MONITOR WELL INSTALLATION DETAILS		
				2	5	10	20	30	40	50	70		90	
805	Boring terminated at 40.0 feet. Groundwater encountered at 17.70 feet at time of drilling. Groundwater encountered at 20.11 feet 24 hours after time of drilling.													
800														
795														
790														
785														
780														
775														
770														
765														
760														
755														
750														
745														
740														
735														
730														
725														
720														
715														
710														
705														
700														
695														
690														
685														
680														
675														
670														
665														
660														
655														
650														
645														
640														
635														
630														
625														
620														
615														
610														
605														
600														
595														
590														
585														
580														
575														
570														
565														
560														
555														
550														
545														
540														
535														
530														
525														
520														
515														
510														
505														
500														
495														
490														
485														
480														
475														
470														
465														
460														
455														
450														
445														
440														
435														
430														
425														
420														
415														
410														
405														
400														
395														
390														
385														
380														
375														
370														
365														
360														
355														
350														
345														
340														
335														
330														
325														
320														
315														
310														
305														
300														
295														
290														
285														
280														
275														
270														
265														
260														
255														
250														
245														
240														
235														
230														
225														
220														
215														
210														
205														
200														
195														
190														
185														
180														
175														
170														
165														
160														
155														
150														
145														
140														
135														
130														
125														
120														
115														
110														
105														
100														
95														
90														
85														
80														
75														
70														
65														
60														
55														
50														
45														
40														

GEOT. WELL 11684-02.GPJ 5/14/19



**BUNNELL-LAMMONS  
ENGINEERING, INC.**  
GEOTECHNICAL AND ENVIRONMENTAL  
CONSULTANTS

**GROUNDWATER MONITORING WELL NO. PZ-21**

PROJECT: Greenpointe Class 2 Landfill

PROJECT NO.: J17-11684-02

CLIENT: Greenpointe Landfill, LLC

START: 12-18-17 END: 12-18-17

LOCATION: Easley, South Carolina

ELEVATION: 833.02

DRILLER: Landprobe, R. Banks

LOGGED BY: R. Doherty

DRILLING METHOD: CME 750; 4-1/4 inch hollow stem auger

DEPTH TO - WATER> INITIAL: ▽ 5.7 AFTER 24 HOURS: ▽ 7.42 CAVING: ☒

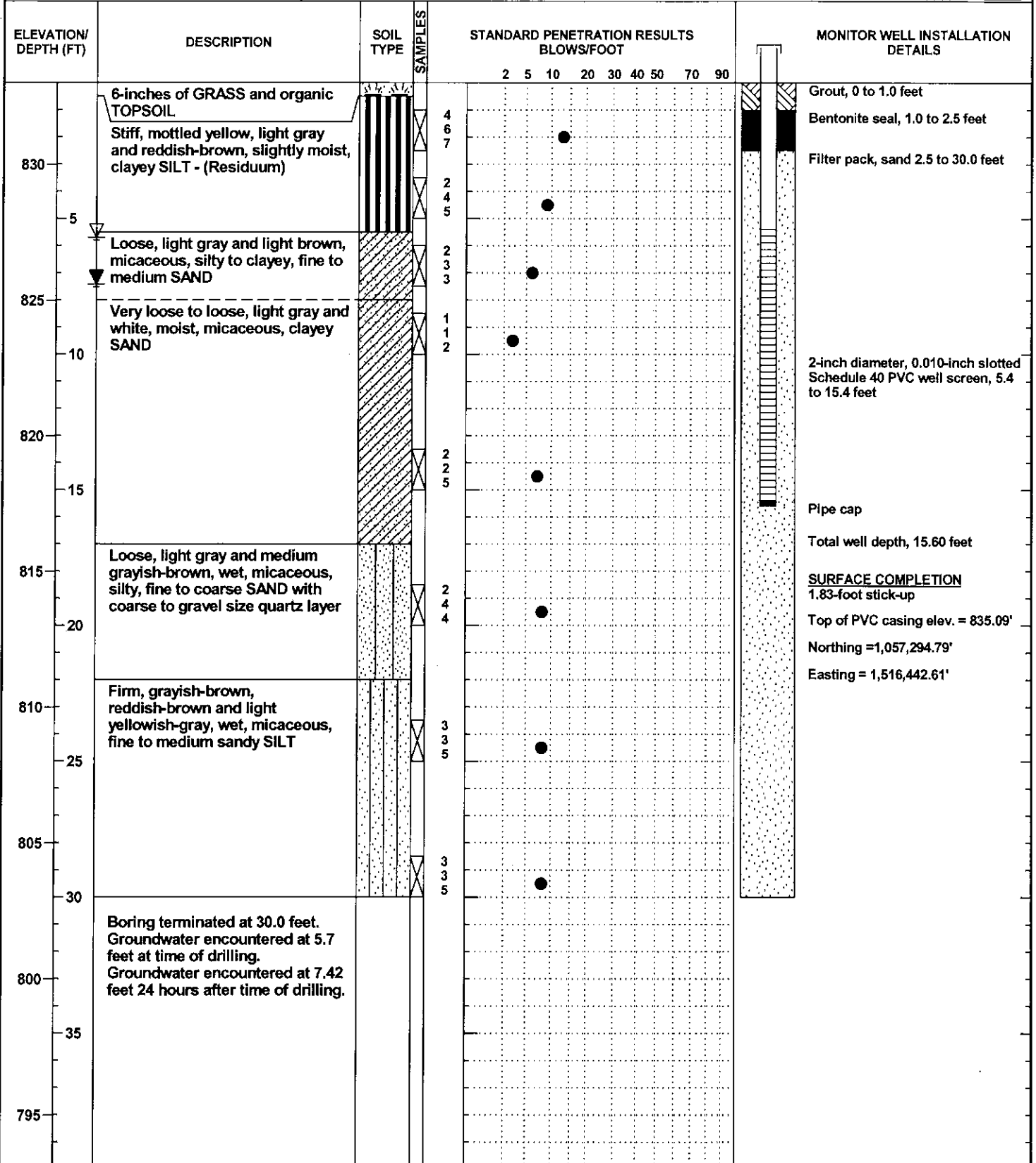

GEO. WELL 11684-02.GPJ 5/14/19



**BUNNELL-LAMMONS  
ENGINEERING, INC.**  
GEOTECHNICAL AND ENVIRONMENTAL  
CONSULTANTS

**GROUNDWATER MONITORING WELL NO. PZ-22**

PROJECT: Greenpointe Class 2 Landfill PROJECT NO.: J17-11684-02  
 CLIENT: Greenpointe Landfill, LLC START: 12-18-17 END: 12-18-17  
 LOCATION: Easley, South Carolina ELEVATION: 846.99  
 DRILLER: Landprobe, R. Banks LOGGED BY: R. Doherty  
 DRILLING METHOD: CME 750; 4-1/4 inch hollow stem auger  
 DEPTH TO - WATER> INITIAL: ▽ 13.88 AFTER 24 HOURS: ▽ 16.69 CAVING: ☒

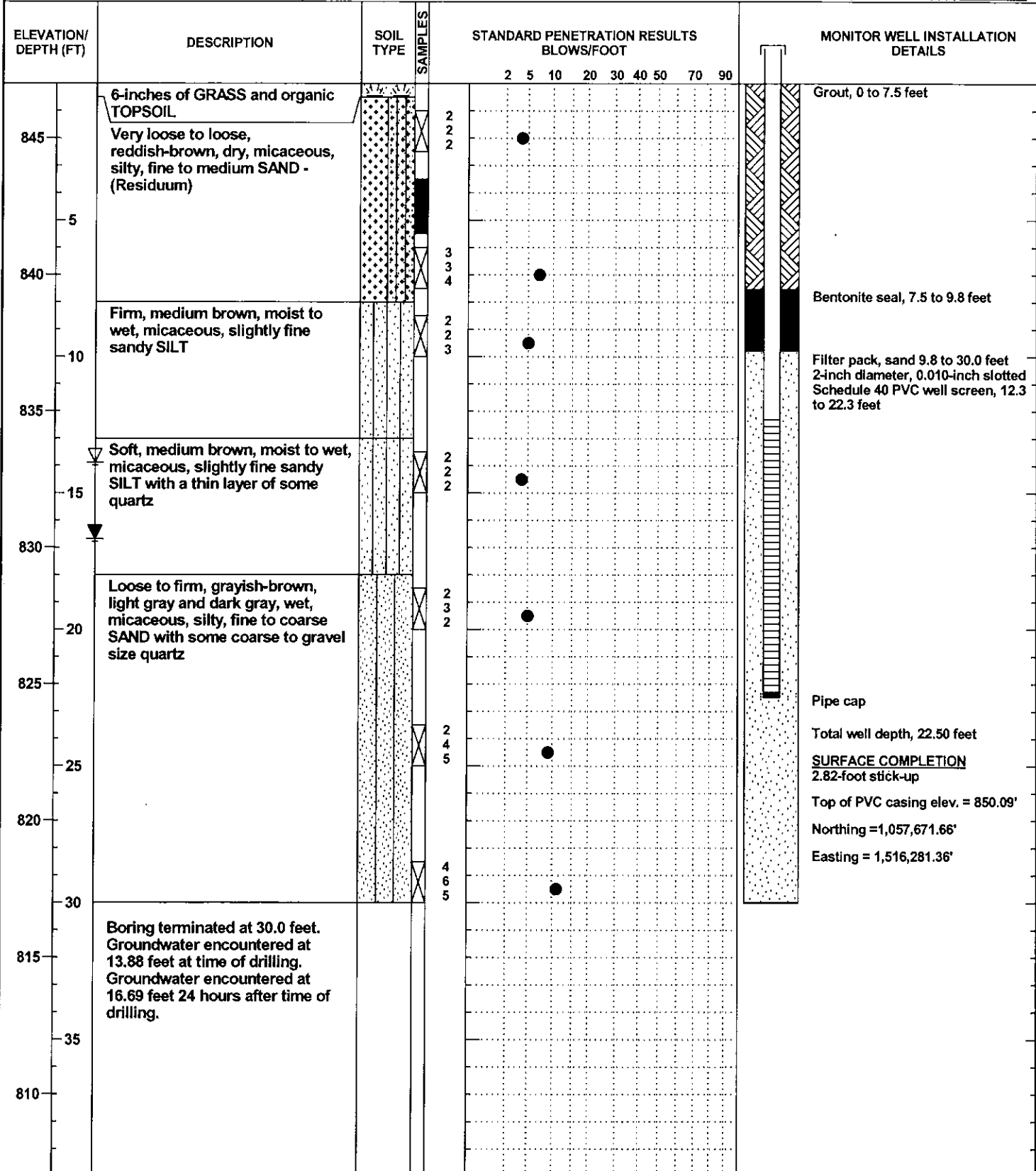

GEOI\_WELL\_11684-02.GPJ\_5/14/19



**BUNNELL-LAMMONS  
ENGINEERING, INC.**  
GEOTECHNICAL AND ENVIRONMENTAL  
CONSULTANTS

**GROUNDWATER MONITORING WELL NO. PZ-23**

PROJECT: Greenpointe Class 2 Landfill

PROJECT NO.: J17-11684-02

CLIENT: Greenpointe Landfill, LLC

START: 12-19-17 END: 12-19-17

LOCATION: Easley, South Carolina

ELEVATION: 834.58

DRILLER: Landprobe, R. Banks

LOGGED BY: R. Doherty

DRILLING METHOD: CME 750; 4-1/4 inch hollow stem auger

DEPTH TO - WATER> INITIAL: ▽ 4.82 AFTER 24 HOURS: ▽ 9.0 CAVING: ▣

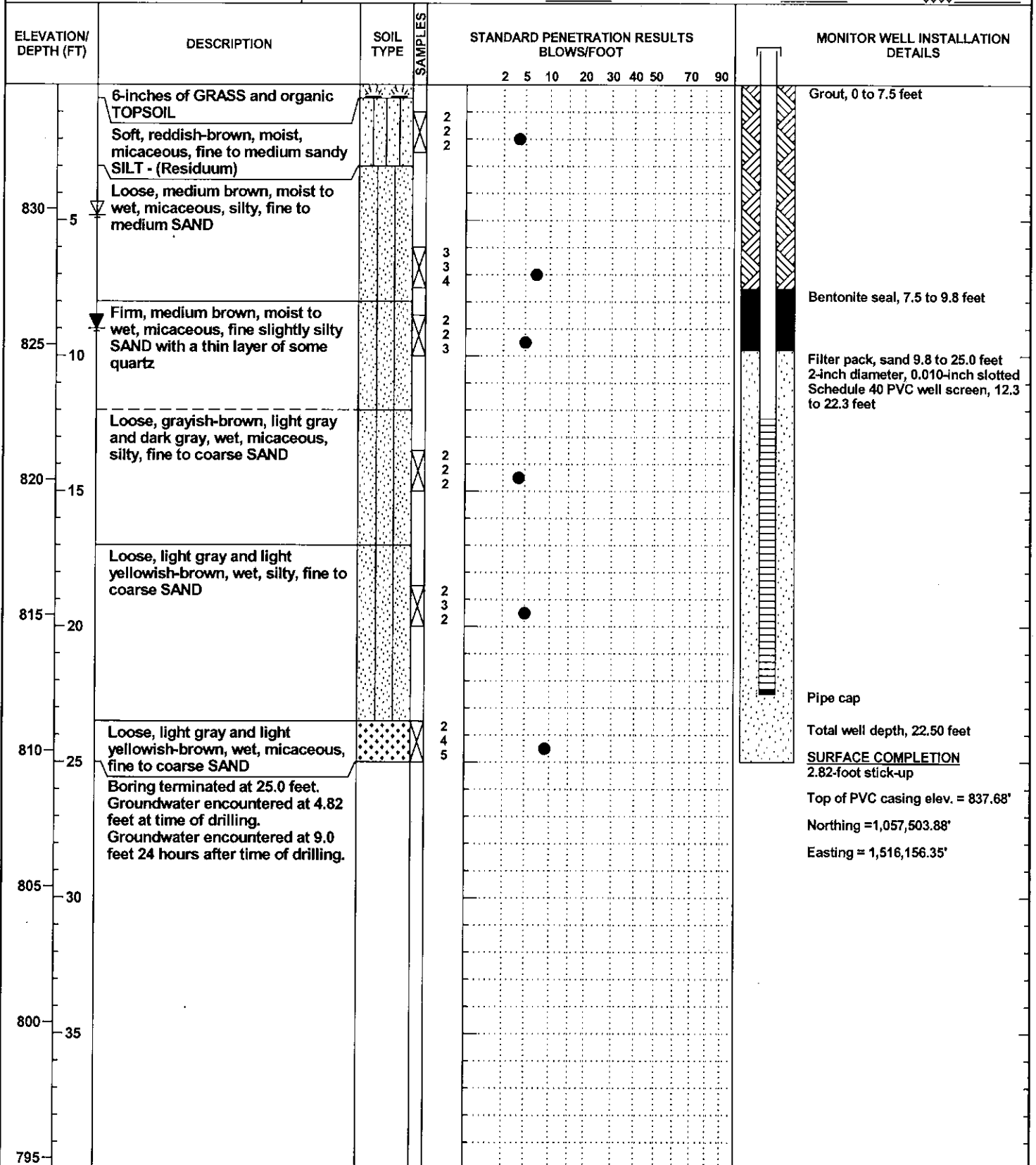

GEOI\_WELL\_11684-02.GPJ 5/14/19



**BUNNELL-LAMMONS  
ENGINEERING, INC.**  
GEOTECHNICAL AND ENVIRONMENTAL  
CONSULTANTS

**GROUNDWATER MONITORING WELL NO. PZ-24**

PROJECT: Greenpointe Class 2 Landfill

PROJECT NO.: J17-11684-02

CLIENT: Greenpointe Landfill, LLC

START: 3-22-18 END: 3-23-18

LOCATION: Easley, South Carolina

ELEVATION: 821.40

DRILLER: Landprobe, S. Dyer

LOGGED BY: B.P. Davis

DRILLING METHOD: CME 750; 4-1/4 inch hollow stem auger

DEPTH TO - WATER> INITIAL: ▽ 13.11 AFTER 24 HOURS: ▽ 13.13 CAVING> ☒

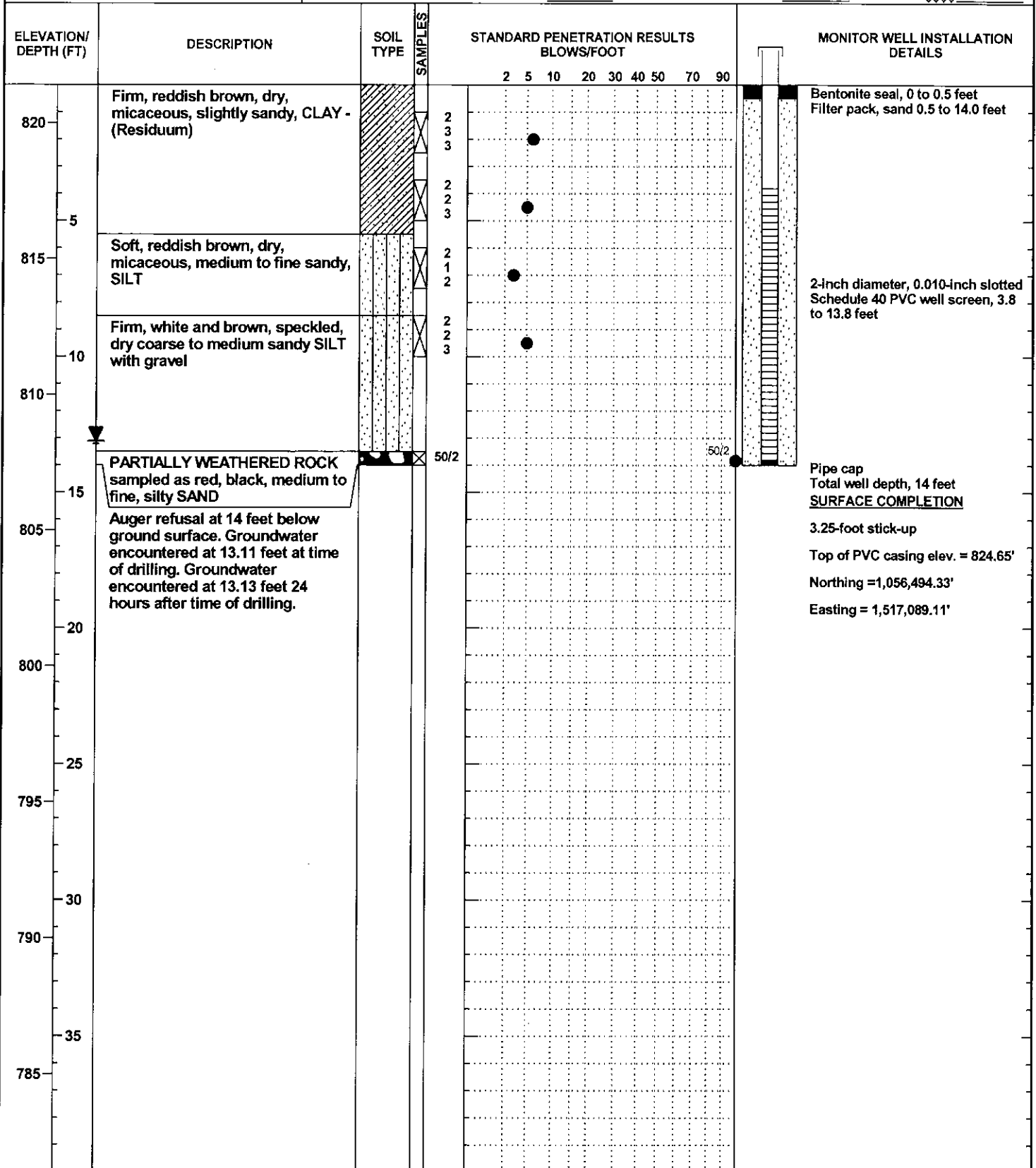



**BUNNELL-LAMMONS  
ENGINEERING, INC.**  
GEOTECHNICAL AND ENVIRONMENTAL  
CONSULTANTS

**GROUNDWATER MONITORING WELL NO. PZ-25**

PROJECT: Greenpointe Class 2 Landfill  
 CLIENT: Greenpointe Landfill, LLC  
 LOCATION: Easley, South Carolina  
 DRILLER: Landprobe, S. Dyer  
 DRILLING METHOD: CME 750; 4-1/4 inch hollow stem auger  
 DEPTH TO - WATER> INITIAL:  $\nabla$  16.2 AFTER 24 HOURS:  $\nabla$  18.87 CAVING  $\nabla$

PROJECT NO.: J17-11684-02  
 START: 3-23-18 END: 3-23-18  
 ELEVATION: 819.71  
 LOGGED BY: M. Parks

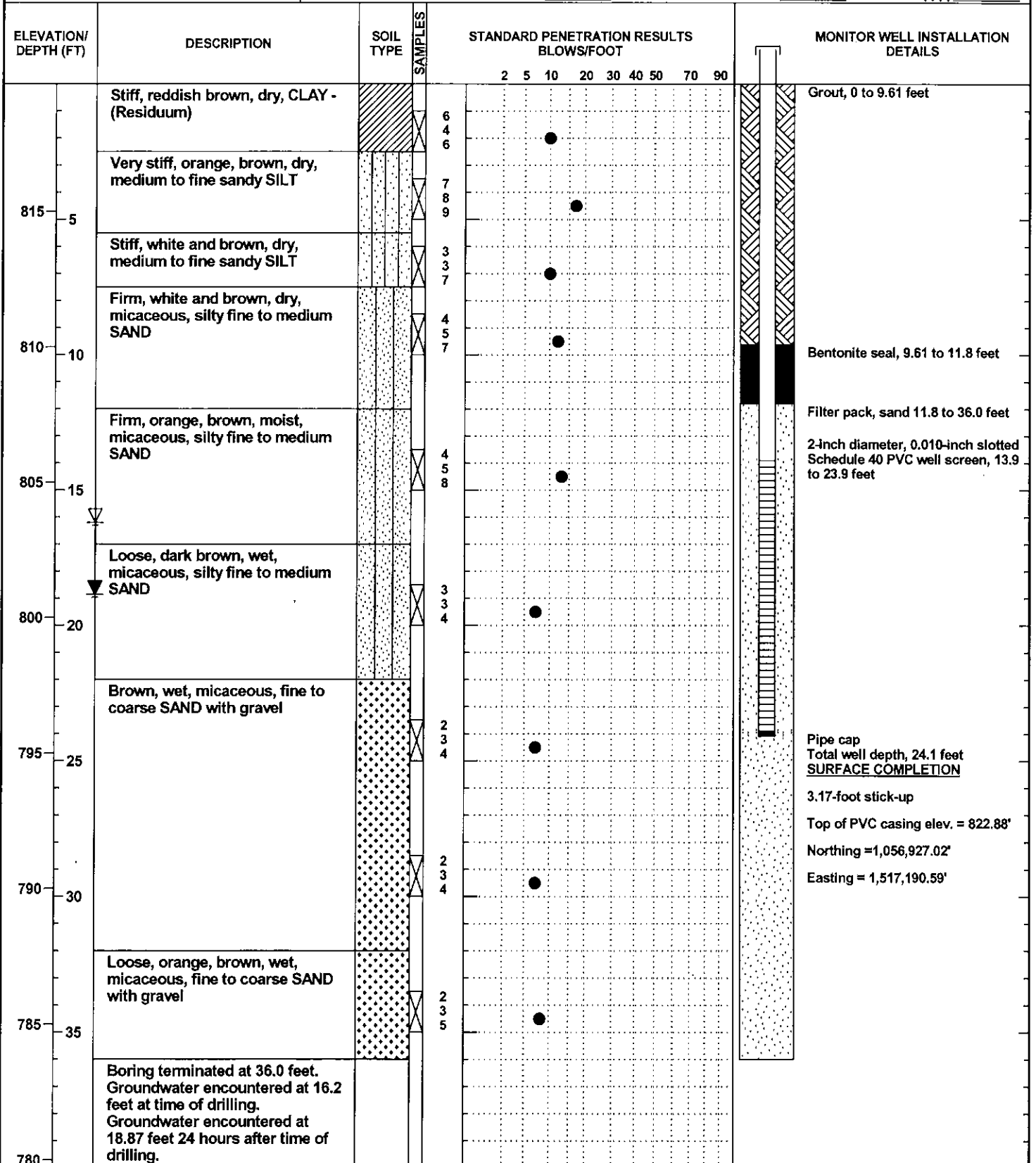

GEOT\_WELL\_11684-02.GPJ 5/14/19

# REPORT OF GEOTECHNICAL ANALYSIS PROPOSED EXPANSION

GREENPOINTE CLASS 2 LANDFILL  
500 HAMLIN ROAD  
EASLEY, ANDERSON COUNTY,  
SOUTH CAROLINA  
SC SOLID WASTE PERMIT #LF2-00001

**Prepared For:**  
Greenpointe Landfill, LLC  
P.O. Box 8028  
Greenville, South Carolina 29604

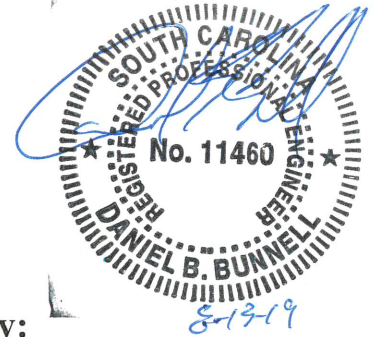
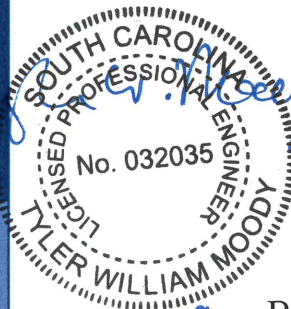

**Prepared by:**  
Bunnell-Lammons Engineering, Inc.  
6004 Ponders Court  
Greenville, South Carolina

BLE Project Number J18-11684-02

August 12, 2019

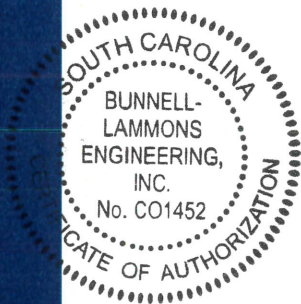

**BLE**

**BUNNELL  
LAMMONS  
ENGINEERING**

6004 Ponders Court | Greenville, SC 29615  
864.288.1265 864.288.4330 info@blecorp.com

[BLECORP.COM](http://BLECORP.COM)





**BUNNELL  
LAMMONS  
ENGINEERING**

August 12, 2019

Mr. Radford Jenkins  
Greenpointe Landfill, LLC  
PO Box 8028  
Greenville, South Carolina, 29604-8028

Attention: Mr. Radford Jenkins

Subject: **Report of Geotechnical Analysis - Proposed Expansion Area  
Greenpointe Class 2 Landfill**  
SC Solid Waste Permit # LF2-00001  
500 Hamlin Road  
Easley, Anderson County, South Carolina  
BLE Project Number J18-11684-02

Dear Mr. Jenkins:

Bunnell Lammons Engineering, Inc. (BLE) is pleased to present this *Report of Geotechnical Analysis* for the proposed expansion to the Greenpointe Class 2 Landfill located in Anderson County, South Carolina. These analyses were performed in conjunction with the preparation of the Site Hydrogeologic Characterization Report by BLE for the proposed expansion which was previously reported under a separate cover. The purpose of these analyses was to evaluate the subgrade settlement and final waste slope stability.

We appreciate the opportunity to serve as your geological and geotechnical consultant on this project and look forward to continuing to work with you at the Greenpointe Class 2 Landfill. If you have any questions, please contact us at (864) 288-1265.

Sincerely,

**BUNNELL LAMMONS ENGINEERING INC.**

Tyler W. Moody, P.E.  
Senior Engineer  
Licensed, South Carolina #32035



Daniel B. Bunnell, P.E.  
Principal Engineer  
Licensed, South Carolina #11460

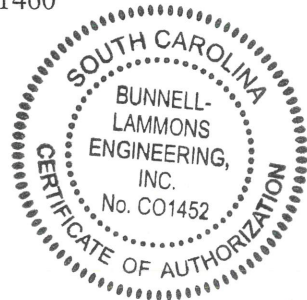
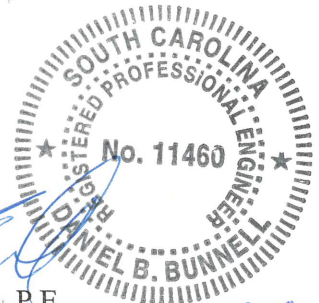



**TABLE OF CONTENTS**

**1.0 PROJECT INFORMATION ..... 1**

**2.0 SITE GEOLOGY AND SUBSURFACE CONDITIONS..... 1**

2.1 Subsurface Conditions ..... 1

**3.0 GEOTECHNICAL ANALYSIS ..... 2**

3.1 Stability of Final C&D Waste Slopes ..... 2

3.2 Subgrade Settlement ..... 3

**4.0 CLOSING..... 4**

**REFERENCES..... 5**



## **Appendices**

Appendix A	Figures
Appendix B	Slope Stability Analysis
Appendix C	Subgrade Settlement / Groundwater Separation with C&D Waste Subgrade
Appendix D	Soil Test Boring Logs and Laboratory Data

## 1.0 PROJECT INFORMATION

The existing Greenpointe Class 2 Landfill is located approximately nine miles north of Williamston, at 500 Hamlin Road in Anderson County, South Carolina (**Figure G-1**). The landfill is currently operated under South Carolina Solid Waste Permit #LF2-00001. Greenpointe Landfill, LLC (GPL) operates the landfill and is currently evaluating the possibility of an expansion outside the existing approximate 20-acre landfill footprint.

The proposed expansion areas consist of approximately 8 acres located adjacent to the west of the side of the current landfill area (Expansion Area A) and a separate waste mound of approximately 15 acres located roughly 500-feet to the east of the current landfill area (Expansion Area B). The proposed expansion will result in a total landfill area of approximately 43 acres. The proposed expansion footprint and base grades have been preliminarily designed by Alliance Consulting Engineers (Alliance). The new landfill footprint would include two new sediment ponds and a new, approximately 23-acre soil borrow area.

South Carolina Department of Health and Environmental Control regulation R.61-107.19, Part IV requires a minimum of 2 feet be maintained between the post settlement bottom elevation of waste and groundwater as established by the Hydrogeological Report. The seasonal high groundwater elevation is presented in the BLE report titled *Site Hydrogeologic Characterization Report – Expansion Area* (Hydrogeologic Report) dated May 16, 2019.

Previous geological reports for the site which were reviewed as part of this evaluation include:

- *Construction, Demolition, and Land Clearing Debris Landfill Plan for the Greenpointe C&D Landfill Site, Revision 3*, Davis & Floyd Inc., May 2008.
- *Report of Limited Geotechnical Exploration – Wasteco C&D Landfill*, by Qore Property Sciences, dated September 6, 2005.
- *Groundwater Detection Monitoring Plan*, David & Floyd Inc., August 2009.
- *Revised Groundwater Detection Monitoring Plan*, HRP Associates Inc., April 2015.
- *Site Hydrogeologic Characterization Report*, BLE, May 2019.

## 2.0 SITE GEOLOGY AND SUBSURFACE CONDITIONS

The site subsurface conditions are summarized below for the purposes of this geotechnical evaluation. The reader is referred to the BLE *Site Hydrogeologic Characterization Report* for a more detailed description and to view specific boring records and laboratory test data. Piezometers PZ-14 through PZ-25 were installed as a part of the BLE Hydrogeologic Report and groundwater elevation data was gathered for 12 months following installation of the piezometers.

### 2.1 Subsurface Conditions

The subject site is located within the Inner Piedmont Belt of the Piedmont Physiographic Province (Piedmont) and is generally characterized by weathered residual material overlying crystalline bedrock that occurs in northeast-southwest trending geologic belts. The bedrock in the area of the site consists primarily of migmatitic granitoid gneiss (*Horton and Dicken 2001*).

The typical residual soil profile in the Piedmont consists of clayey and silty soils near the surface, where soil weathering is more advanced. The residual soil profile generally becomes coarser with depth. The

near surface clayey and silty soils are underlain by micaceous sandy silts and silty sands. Residual soil zones developed by the *in-situ* chemical weathering of bedrock and are commonly referred to as “saprolite.” Saprolite usually consists of sand with lesser amounts of silt, clay, and large rock fragments. The thickness of the saprolite in the Piedmont ranges from a few feet to more than 100 feet.

The soils encountered while drilling for the *Site Hydrogeologic Characterization* were alluvial sediments or residual soils derived from the in-place chemical weathering of the underlying gneiss and schist bedrock in the surrounding region. Alluvial soils are present along the floodplain of the unnamed tributary in the center of the site, which defines the western boundary of the expansion area. Where encountered during drilling (PZ-14 and PZ-15), these soils consisted of very soft and very micaceous sandy-silt. Field and laboratory USCS classifications of these soils are SM and SC-SM. Where encountered, this component ranges in thickness from 3.0 to 4.0 feet. Standard penetration resistance values (N-values) range from weight of the hammer to 1, indicating a very loose average consistency. However, the proposed expansion areas are not located within this floodplain area.

The shallow residual soil component consists of slightly micaceous sandy-silts, silty-sand, clayey-sand, and high plasticity silts or clays. Field and laboratory USCS classifications of these soils are ML, SM, SC, MH, CH, and SW-SM. The shallow residual soil component grades with depth into a deeper residual soil component that is coarser-grained, less plastic, micaceous sandy-silt, sandy-silty-clay and silty-sand, which extends to the borehole termination depth or the depth of the partially weathered rock and/or auger refusal. Field and laboratory USCS classifications of the deeper residual soils are mostly CL and SM. N-values for residual soils were 13 or less, indicating a loose average consistency.

The boundary between soil and rock is not sharply defined. A transitional zone of partially weathered rock is normally found below the saprolite and overlying the parent bedrock. Partially weathered rock is defined, for engineering purposes, as residual material with standard penetration resistance (ASTM 1586) in excess of 100 blows per foot (bpf). For the geotechnical analysis, the depth to bedrock was conservatively generalized as 60 feet below the pre-construction ground surface. A value of 60 feet was selected to reflect the greatest soil thickness based on available data from the site borings.

Historical soil test boring information by Qore, reported as a part of the original landfill site permit application, was reviewed along with laboratory consolidation test results. The historical information was consistent with the findings of the expansion subsurface exploration.

### **3.0 GEOTECHNICAL ANALYSIS**

The analysis performed by BLE consisted of evaluation of the following components:

- (1) stability of proposed final C&D waste slopes, and
- (2) subgrade settlement resulting from the full proposed height of the landfill.

Our evaluation was based upon review of the subsurface information and laboratory data summarized in Section 1.0 of this report along with the proposed initial and finished surface grading plans provided by Alliance Consulting Engineers.

#### **3.1 Stability of Final C&D Waste Slopes**

The analysis included the tallest planned waste slopes of Expansion Areas A and B as presented on BLE Cross Sections A-A', B-B', and C-C' located in Appendix A. Static stability analysis was performed using

the computer program Slope/W by Geo-Slope International. Both circular and block failure modes were considered. Analysis of potential interface sliding (or, translational sliding) along the waste to soil subgrade and soil subgrade to bedrock interface were considered. The shear strengths for the various layer materials used in the analyses were conservatively estimated using published relationships between index testing and soil shear strengths, and published strength parameters for waste. A factor of safety of 1.5 or more is considered acceptable for long term (steady state) static conditions.

Detailed analysis assumptions, conditions, and results are presented in our Calculation Documentation in Appendix B. A summary of the analysis results is presented in Table 1.

**Table 1: Global Slope Stability Analysis Results – Planned Expansion Areas A and B.**

Analysis Area	Cross Section/ File Designation	Minimum Calculated FS	FS Acceptable
Expansion Area A – South Slope	A-A' / 1.C.1	3.1	Yes
Expansion Area A – East Slope	B-B' / 2.C.3	2.9	Yes
Expansion Area B – Southeast Slope	C-C' / 3.C.4	3.2	Yes

As shown in Table 1, the lowest calculated factor of safety for each slope was greater than the minimum acceptable value of 1.5 for long-term, static conditions.

The analysis assumes proper bonding between existing C&D wastes and future placed C&D waste placed to achieve the planned final slope inclination. Suitable bonding of the C&D wastes assumes the waste has been keyed into the existing waste materials through benching of the existing waste surfaces, and that softened or weathered waste cover surface soils have been stripped prior to waste placement. Prior to the placement of C&D wastes above the soil subgrade, the soil subgrade is to be maintained in its final constructed condition (e.g. well compacted, without excess moisture or softening due to moisture) until C&D waste is placed.

### 3.2 Subgrade Settlement

An evaluation of potential settlements of the planned subgrade soils when subjected to the proposed waste loads from the planned future expanded landfill grades was performed. Compressibility parameters for the soil profile were estimated based on published correlations with standard penetration resistance, previous consolidation laboratory testing by Qore Property Sciences (Qore 2005), and our experience with similar soils. The subgrade settlement was estimated through the highest waste load along the approximate centerline of each waste mound and at locations along the selected alignment where the pre-settlement groundwater separation is to be the thinnest.

Settlement calculation points are shown on **Appendix A, Figure G-3**). The settlement calculations performed for each expansion area are presented in the “Subgrade Settlement” section of **Appendix C** of this report. The maximum total subgrade settlement from the waste loading due to the expansion is estimated to be approximately 17.2 inches (1.43 feet). The maximum settlement was found at the point of maximum waste and structural fill thickness, near boring B-3. The settlement magnitude at any given location will vary with the waste height, the thickness of the subgrade soil layer overlying rock and the thickness of new structural fill. Subgrade settlements near the perimeter of the landfill as a result of waste placement are



expected to be on the order of 0.2 feet or less. Our analysis assumes the landfill will be graded to provide firm residual soil or compacted structural fill at the subgrade elevations and that waste will not be placed over soft alluvial soil.

**Groundwater Separation with C&D Waste Subgrade:** Based on the furnished planned subgrade elevations and the estimated subgrade settlement at specific points of interest, the post-settlement separation between the bottom of the C&D waste subgrade and the seasonal high groundwater elevation will range from 2.07 to 5.38 feet. Documentation of the post-settlement separation of the C&D waste subgrade with the seasonal high groundwater level is presented in **Appendix C** of this report.

#### **4.0 CLOSING**

Based on our analysis of the proposed landfill expansion global slope stability and subgrade settlement, the proposed landfill grades will result in acceptable factors of safety for slope stability and the post-settlement subgrade separation from groundwater will be greater than the minimum required value. Our results are based on the conditions detailed in this report and the detailed calculation documentation provided in the appendices.

Bunnell-Lammons Engineering, Inc. appreciates the opportunity to provide professional geotechnical services on this project. If you have any questions concerning this report or the attached calculations, please contact us.



## REFERENCES

Bunnell-Lammons Engineering, Inc., September 20, 2017, *Site Hydrogeologic Characterization Work Plan*, BLE Project Number J17-11684-01.

Bunnell-Lammons Engineering, Inc., May 16, 2019, *Site Hydrogeologic Characterization Report – Expansion Area* BLE Project Number J17-11684-02.

Davis & Floyd Inc., May 2008, *Construction, Demolition, and Land Clearing Debris Landfill Plan for the Greenpointe C&D Landfill Site, Revision 3*, Davis & Floyd Inc. Job Number 11967.00.

David & Floyd Inc., August 2009, *Groundwater Detection Monitoring Plan*, Davis & Floyd Inc. Job Number 11967.00.

HRP Associates Inc., April 13, 2015. *Revised Groundwater Detection Monitoring Plan*, HRP Associates Inc., Job Number GRE4713.GW.

Qore Property Sciences, September 6, 2005. *Report of Limited Geotechnical Exploration – Wasteco C&D Landfill*.



## **APPENDIX A**

### **FIGURES**

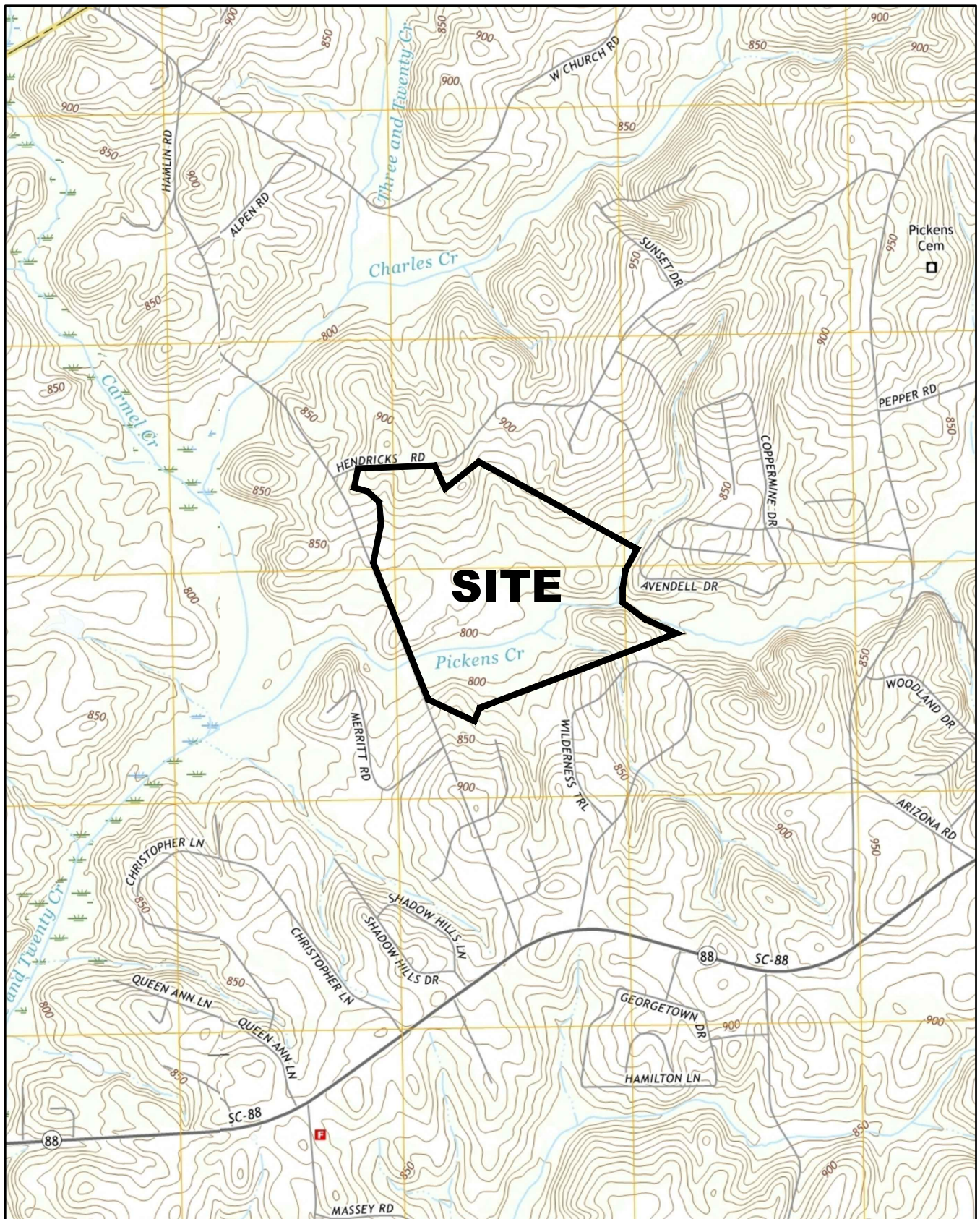

REFERENCE:  
USGS TOPOGRAPHIC MAP, 7.5 MINUTE SERIES,  
EASLEY, FIVE FORKS, LIBERTY AND PIERCETOWN, S.C.  
QUADRANGLES, 2014, 2017, 2014 AND 2014.

DRAWN:	KLW	DATE:	4-26-19
CHECKED:	DPO	CAD:	GREENPOINTE-02SLM
APPROVED:	DBB	JOB NO:	J18-11684-02

**BLE** | **BUNNELL  
LAMMONS  
ENGINEERING**  
6004 Ponders Court, Greenville, SC 29615  
Phone: (864) 288-1265 Fax: (864) 288-4430

SITE LOCATION MAP  
GREEN POINTE CLASS 2 LANDFILL  
EASLEY, SOUTH CAROLINA

FIGURE

**G-1**

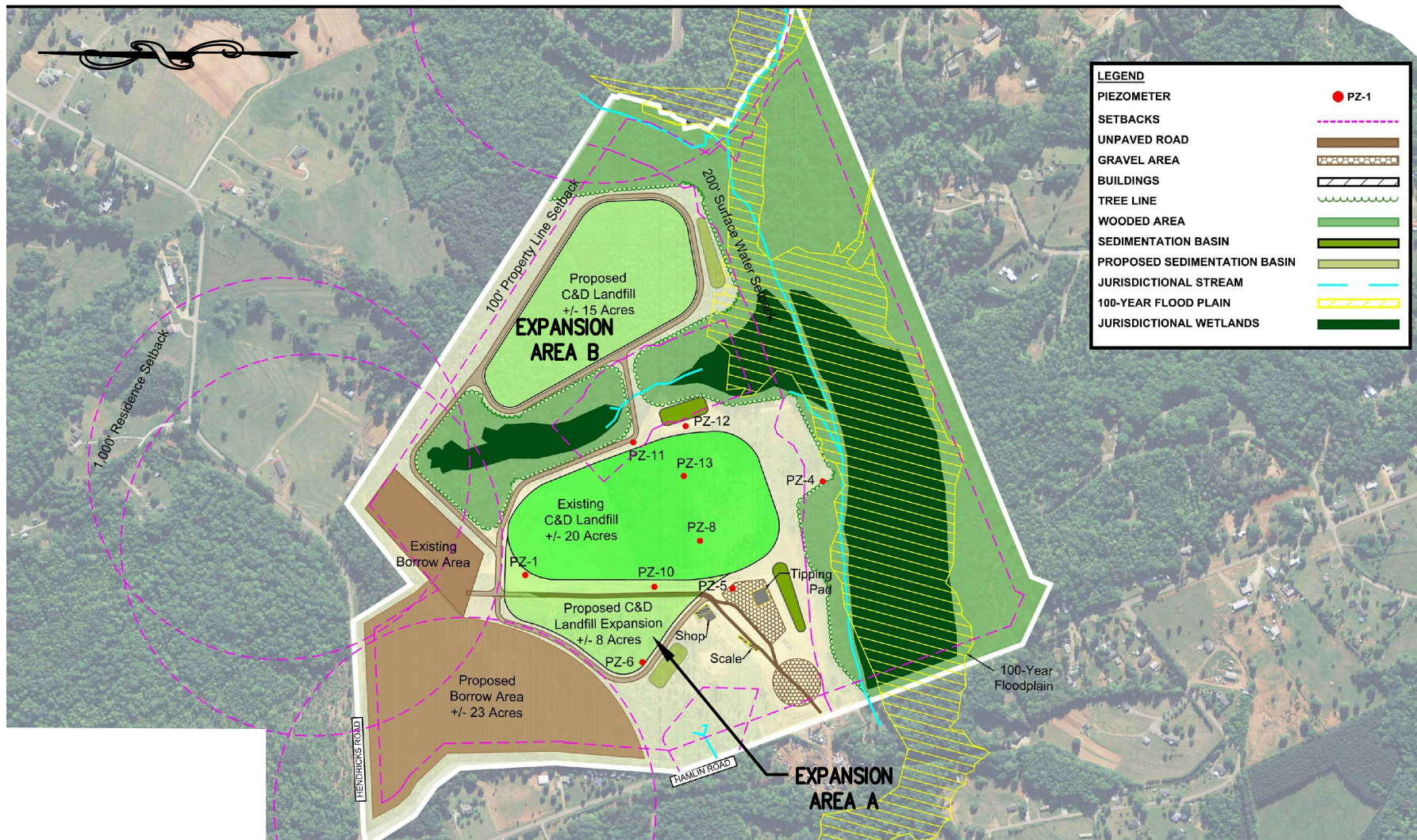

REFERENCE:  
DRAWING TITLED "MASTER DEVELOPMENT PLAN" BY  
ALLIANCE CONSULTING ENGINEERS, INC. DATED JANUARY 13, 2017.

DRAWN:	ACE	DATE:	4-26-19
CHECKED:	DPO	CAD:	GREENPOINTE-02PEA
APPROVED:	DBB	JOB NO:	J18-11684-02

**BLE** | **BUNNELL  
LAMMONS  
ENGINEERING**  
6004 Ponders Court, Greenville, SC 29615  
Phone: (864) 288-1265 Fax: (864) 288-4430

PROPOSED EXPANSION AREAS  
GREENPOINTE CLASS 2 LANDFILL  
EASLEY, SOUTH CAROLINA

FIGURE

**G-2**

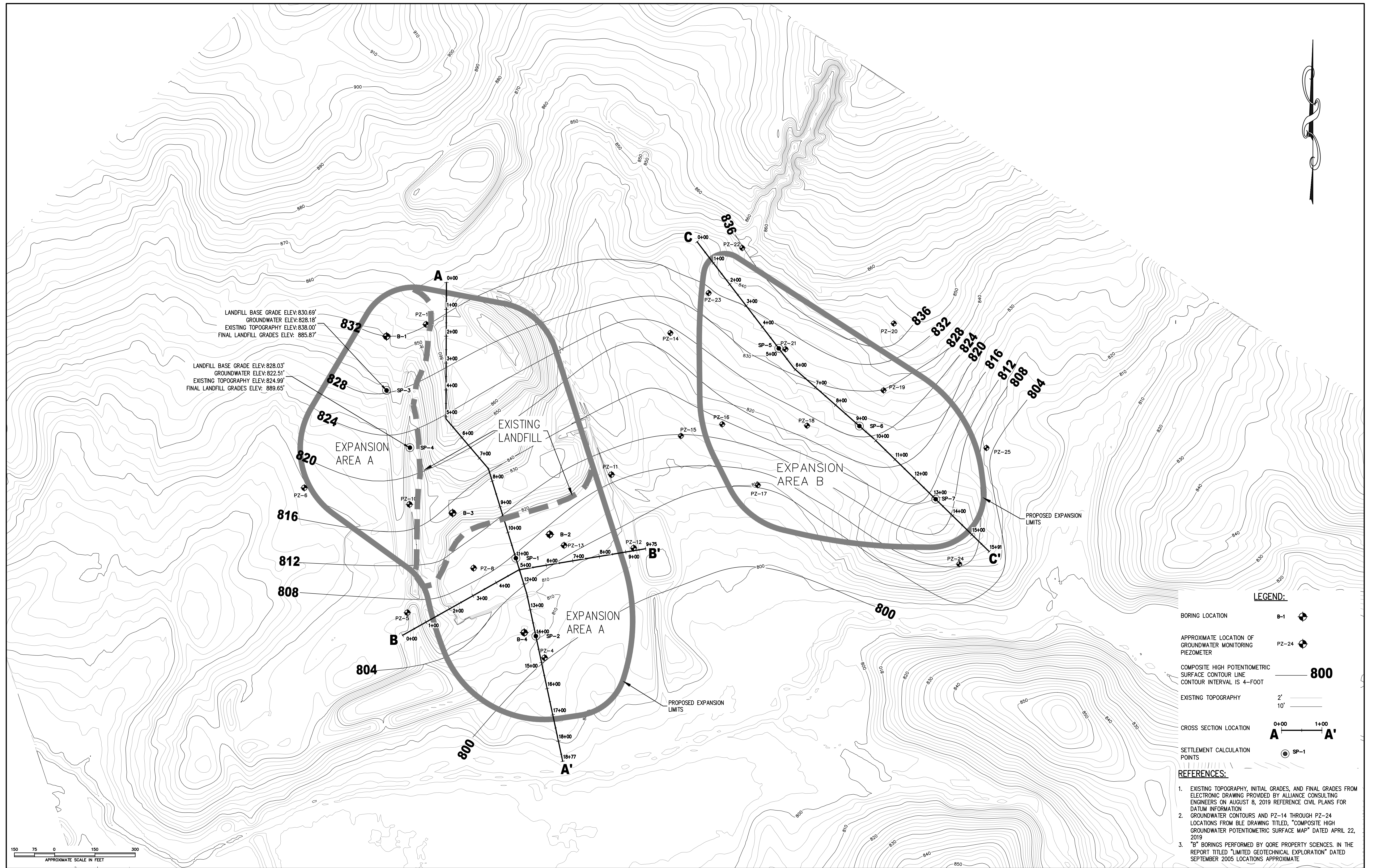

**LEGEND:**

- BORING LOCATION B-1
- APPROXIMATE LOCATION OF GROUNDWATER MONITORING PIEZOMETER PZ-24
- COMPOSITE HIGH POTENTIOMETRIC SURFACE CONTOUR LINE CONTOUR INTERVAL IS 4-FOOT 800
- EXISTING TOPOGRAPHY 2' 10'
- CROSS SECTION LOCATION A 0+00 1+00 A'
- SETTLEMENT CALCULATION POINTS SP-1

**REFERENCES:**

1. EXISTING TOPOGRAPHY, INITIAL GRADES, AND FINAL GRADES FROM ELECTRONIC DRAWING PROVIDED BY ALLIANCE CONSULTING ENGINEERS ON AUGUST 8, 2019 REFERENCE CIVIL PLANS FOR DATUM INFORMATION
2. GROUNDWATER CONTOURS AND PZ-14 THROUGH PZ-24 LOCATIONS FROM BLE DRAWING TITLED, "COMPOSITE HIGH GROUNDWATER POTENTIOMETRIC SURFACE MAP" DATED APRIL 22, 2019
3. "B" BORINGS PERFORMED BY QORE PROPERTY SCIENCES, IN THE REPORT TITLED "LIMITED GEOTECHNICAL EXPLORATION" DATED SEPTEMBER 2005 LOCATIONS APPROXIMATE

NO.	REVISIONS DESCRIPTION	BY

DRAWN: KLW	DATE: 6-26-19
CHECKED: TWM	CAD FILE: GREENPOINT-02PROD
APPROVED:	JOB NO: J18-11684-02

**BLE** | **BUNNELL LAMMONS ENGINEERING**

6004 Ponders Court, Greenville, SC 29615  
Phone: (864) 288-1265 Fax: (864) 288-4430

SITE PLAN - EXISTING CONDITIONS WITH COMPOSITE HIGH GROUNDWATER  
GREENPOINT CLASS II LANDFILL  
ANDERSON COUNTY, SOUTH CAROLINA

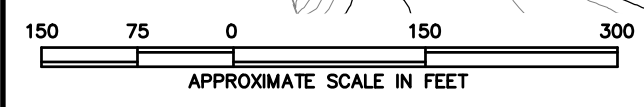
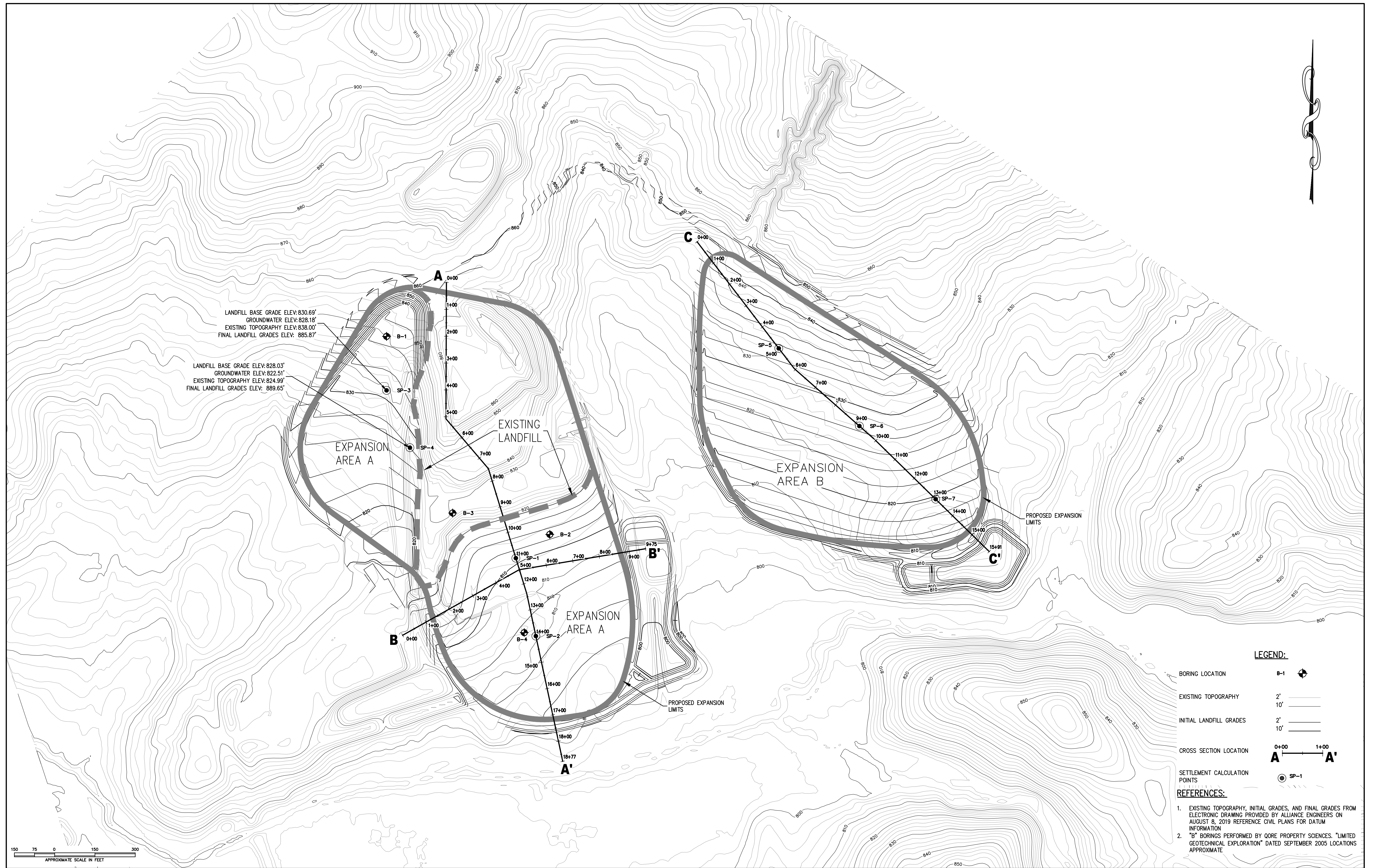

NO.	REVISIONS DESCRIPTION	BY

DRAWN:	KLW	DATE:	6-26-19
CHECKED:	TWM	CAD FILE:	GREENPOINT-02PROD
APPROVED:		JOB NO.:	J18-11684-02

**BLE** | BUNNELL LAMMONS ENGINEERING  
6004 Ponders Court, Greenville, SC 29615  
Phone: (864) 288-1265 Fax: (864) 288-4430

SITE PLAN - EXISTING CONDITIONS WITH INITIAL GRADES  
GREENPOINT CLASS II LANDFILL  
ANDERSON COUNTY, SOUTH CAROLINA

FIGURE NO.  
**G-4**



NO.	REVISIONS DESCRIPTION	BY

DRAWN: KLV	DATE: 6-26-19
CHECKED: TWM	CAD FILE: GREENPOINT-02PROD
APPROVED:	JOB NO: J18-11684-02

**BLE** | **BUNNELL LAMMONS ENGINEERING**

5004 Ponders Court, Greenville, SC 29615  
Phone: (864) 288-1265 Fax: (864) 288-4430

SITE PLAN - EXISTING CONDITIONS WITH FINAL GRADES  
GREENPOINT CLASS II LANDFILL  
ANDERSON COUNTY, SOUTH CAROLINA

**LEGEND:**

- EXISTING TOPOGRAPHY
- LANDFILL FINAL GRADES
- LANDFILL INITIAL GRADES
- GROUNDWATER

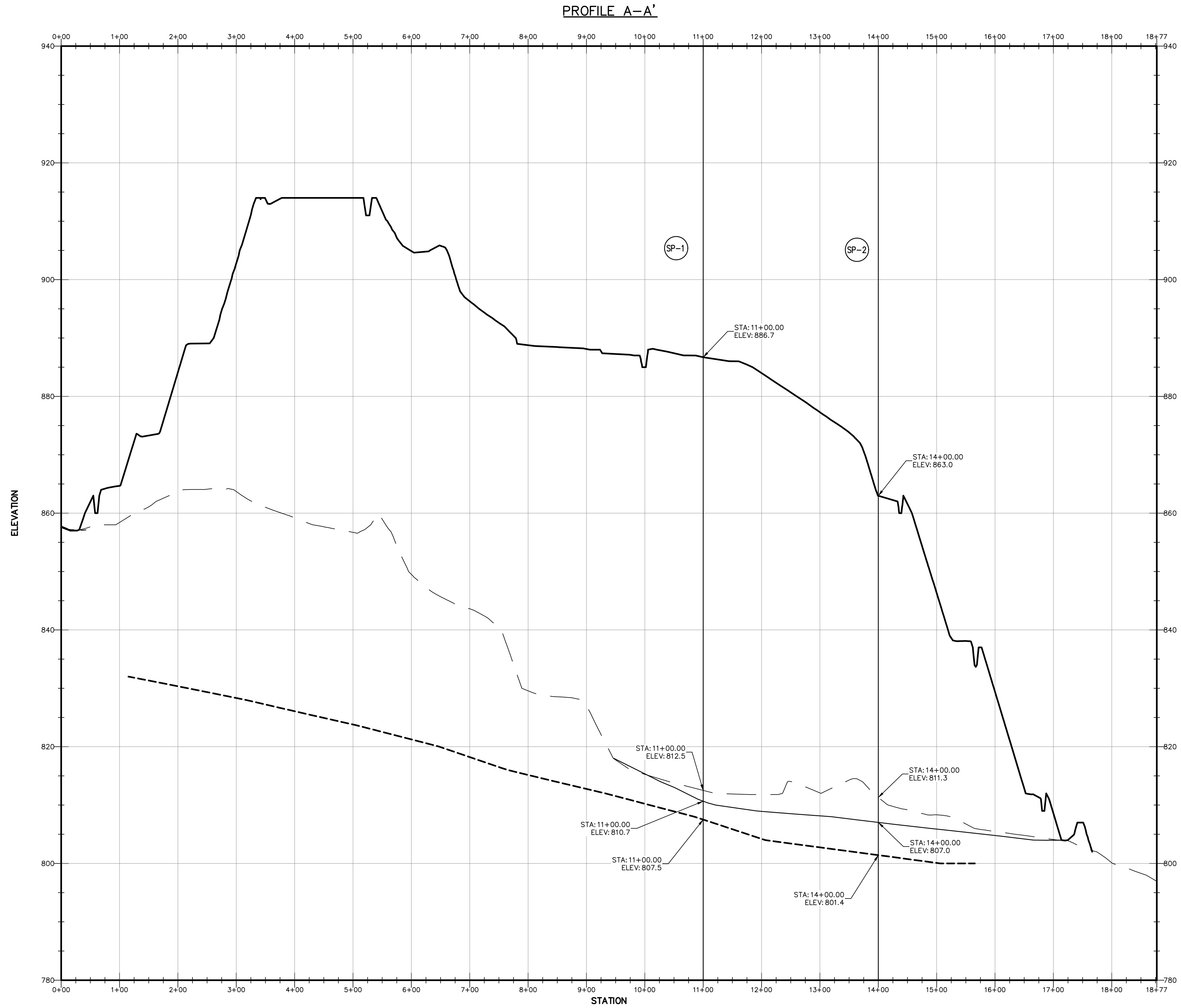

HORIZONTAL SCALE: 1"=100'  
 VERTICAL SCALE: 1"=10'

No.	REVISIONS DESCRIPTION	BY

DRAWN: K LW	DATE: 6-26-19
CHECKED: T WM	CAD FILE: GREENPOINT-02PROD
APPROVED:	JOB NO: J18-11684-02



PROFILE A-A'  
 GREENPOINT CLASS II LANDFILL  
 ANDERSON COUNTY, SOUTH CAROLINA

**LEGEND:**

- EXISTING TOPOGRAPHY
- LANDFILL FINAL GRADES
- LANDFILL INITIAL GRADES
- GROUNDWATER

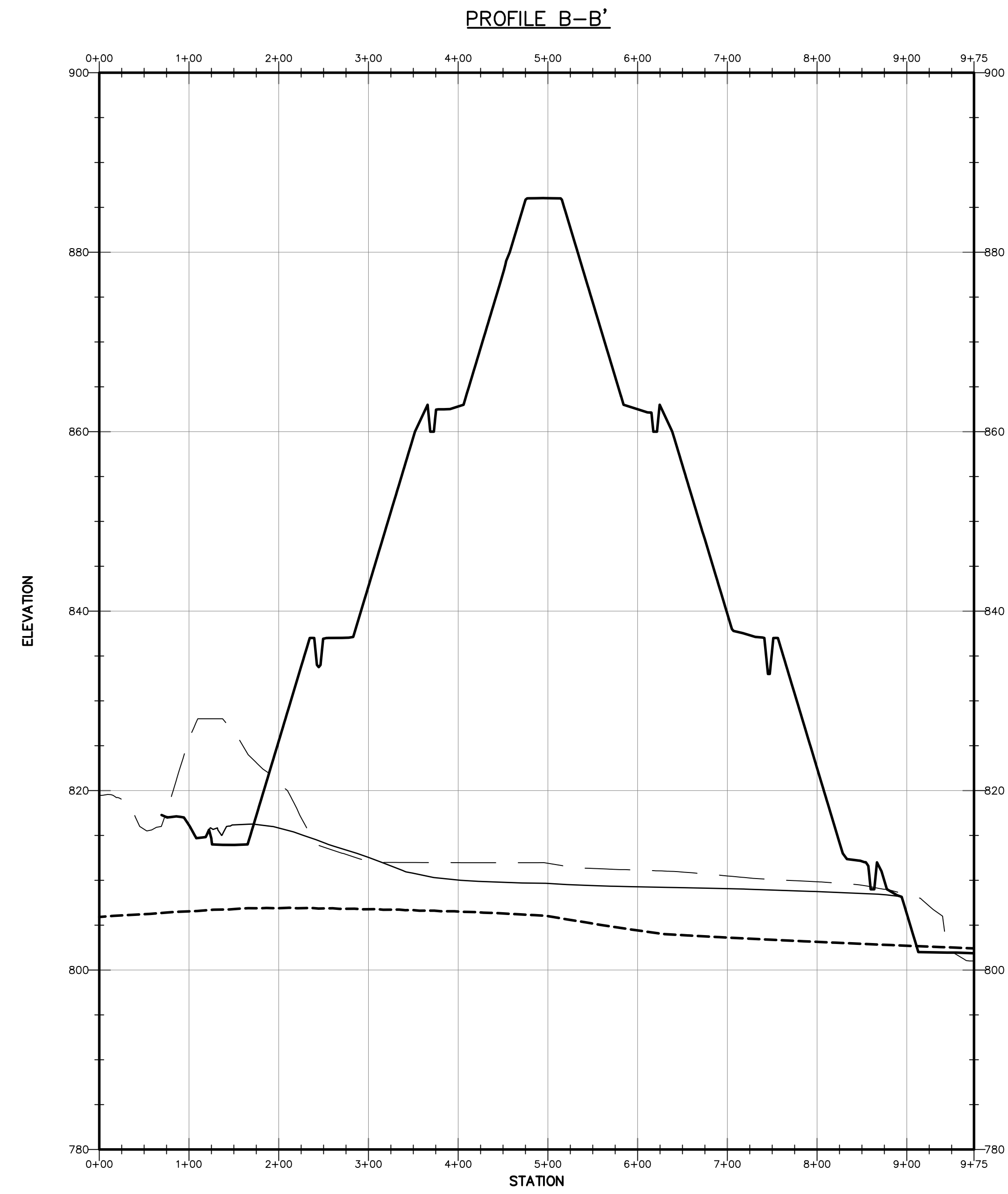

HORIZONTAL SCALE: 1"=100'  
 VERTICAL SCALE: 1"=10'

No.	REVISIONS DESCRIPTION	BY

DRAWN: K LW	DATE: 6-26-19
CHECKED: T W M	CAD FILE: GREENPOINT-02PROD
APPROVED:	JOB NO: J18-11684-02

6004 Ponders Court, Greenville, SC 29615  
 Phone: (864) 288-1265 Fax: (864) 288-4430

**BUNNELL LAMMONS ENGINEERING**

PROFILE B-B'  
 GREENPOINT CLASS II LANDFILL  
 ANDERSON COUNTY, SOUTH CAROLINA



**LEGEND:**

- EXISTING TOPOGRAPHY
- LANDFILL FINAL GRADES
- LANDFILL INITIAL GRADES
- GROUNDWATER

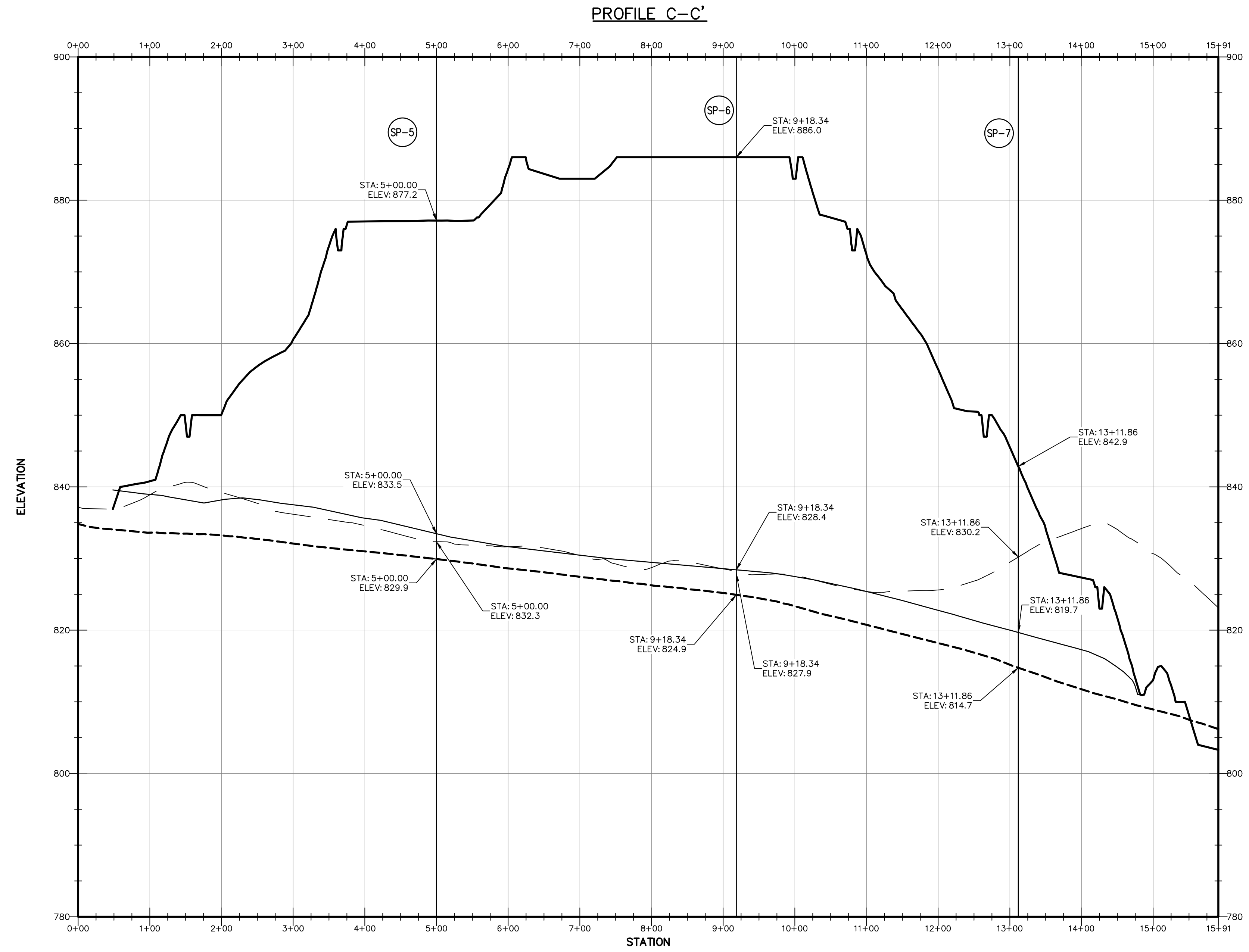

HORIZONTAL SCALE: 1"=100'  
 VERTICAL SCALE: 1"=10'

No.	REVISIONS DESCRIPTION	BY

DRAWN: KLW	DATE: 6-26-19
CHECKED: TWM	CAD FILE: GREENPOINT-02PROD
APPROVED:	JOB NO: J18-11684-02

6004 Ponders Court, Greenville, SC 29615  
 Phone: (864) 288-1265 Fax: (864) 288-4430

BUNNELL LAMMONS ENGINEERING

PROFILE C-C'  
 GREENPOINT CLASS II LANDFILL  
 ANDERSON COUNTY, SOUTH CAROLINA

## **APPENDIX B**

### **SLOPE STABILITY ANALYSIS**

# CALCULATION DOCUMENTATION SLOPE STABILITY ANALYSIS FOR PROPOSED EXPANSION AREA

GREENPOINTE CLASS 2 LANDFILL  
ANDERSON COUNTY, SOUTH CAROLINA

BLE Project No. J17-11684-02

Prepared By:

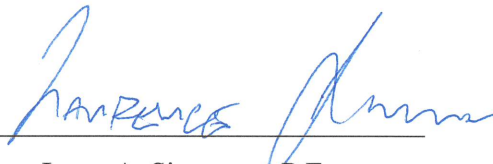

Larry A. Simonson, P.E.  
Licensed SC #33629



Date:

August 12, 2019

Reviewed By:

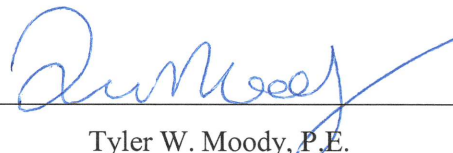

Tyler W. Moody, P.E.  
Licensed SC #32035

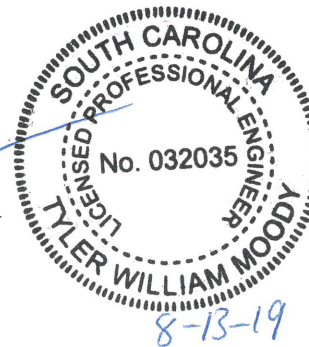

Date:

August 12, 2019

Bunnell-Lammons Engineering, Inc.  
Greenville, South Carolina  
864-288-1265 (Voice)  
864-288-4430 (Fax)



## PURPOSE

1. Analyze the global slope stability of the construction and demolition (C&D) waste slopes for the proposed Expansion Area A and Expansion Area B.
2. A minimum long term static factor of safety (F.S.)  $\geq 1.5$  is recommended.

## DESCRIPTION OF ANALYSIS

### General Conditions

1. Historic laboratory testing and geotechnical soil test borings performed by QORE Property Sciences, Inc was available from the document titled *Report of Limited Geotechnical Exploration (for) WASTECO C&D Landfill* (2005), reported as a portion of the *Report Construction, Demolition, and Land Clearing Debris Landfill Plan for the Greenpointe C&D Landfill Site* by Davis & Floyd, Inc. (2008). Historic laboratory testing included 1-D consolidation testing and percent finer than No. 200 sieve testing.
2. BLE’s previously submitted *Site Hydrogeologic Characterization Report- Expansion Area* (2019) was available for the analysis. The report provided information on the site’s groundwater levels and subsurface profiles. The report included near surface ( $\leq 40$  feet in depth) borings performed at the time of groundwater well installations and laboratory testing performed on split spoon, bulk, and undisturbed Shelby tube samples. Laboratory testing included grain size and Atterberg limits, and hydraulic conductivity.
3. Base grades, final waste grades, and the site’s existing grades were provided by Alliance Consulting Engineers within the Project Drawings *Civil Design Plans for the Class II C&D Greenpointe Landfill Located in Anderson County, SC* dated May 2018. Specific references are:
  - a. Existing Grades from Topographic Survey by F&S Surveyors, Engineers & Planners, Inc. dated February 8, 2017.
  - b. Base Grades from figures *Base Elevation Grading and Storm Drainage Plan – Cell 1 & Base Elevation Grading and Storm Drainage Plan – Cell 2* from the Project Drawings, dated May 2018..
  - c. Final Grades from figures *Final Elevation – Lift 3 Grading and Storm Drainage Plan Cell 2* and *Final Elevation – Lift 5 Grading and Storm Drainage plan – Cell 1* from the Project Drawings, dated May 2018.
4. Groundwater levels are based on the Potentiometric Contour Map presented in the *Site Hydrogeologic Characterization Report- Expansion Area* (BLE 2019).
5. Mapping of the top of bedrock was not reported within the available investigation reports (QORE 2005, Davis & Floyd 2008, BLE 2019). The area geology consists of a Piedmont residual soils, which typically encounters a transitional zone of partially weathered rock (PWR) prior to encountering bedrock (BLE 2019). PWR and auger refusal indicating possible top of bedrock was encountered in only two borings (B-4 and PZ-24), with the deeper bedrock encountered at 44 feet below ground surface. Therefore, bedrock elevations were conservatively estimated to be approximately 60 feet below the existing ground surface for the analysis.
6. The subsurface of the landfill consists of the following layers, from the top of landfill subgrade down:



- a. Where necessary, the existing topography will be raised to design grades using onsite structural fill. Structural fill soils on the site will consist of excavated residual clayey and silty sands and sandy clays and silts. The thickest structural fill areas will require approximately 9 feet of fill to achieve the proposed design subgrade.
  - b. A layer of residual, sandy silts, silty sand, clayey-sand and some high plasticity clay ranging from 13 to 30 feet thick within the subgrade below the landfill subgrades. Generally, this layer of near surface residual material exhibited loose consistency based on standard penetration test (SPT) blow counts.
  - c. A layer of increasingly higher, firmer (SPT blow counts  $\geq 11$ ) consistency residual sandy silts and silty sands extending from the bottom of the near surface residual soils to the top of bedrock.
  - d. Bedrock.
7. Shear strengths of the underlying residual material were conservatively assumed based on typical values for sand and silty sand, SPT N-values from the historic and current soil test borings, and lab testing performed in the available reports (QORE 2005, Davis & Floyd 2008, BLE 2019).
  8. Shear strength of the construction and demolition (C&D) waste was estimated from published literature and our experience with similar materials. C&D waste typically includes larger size materials that provide for higher friction angles. Given the potential variability of the material, we have conservatively estimated the C&D waste strengths and unit weight, though the referenced literature suggests that the C&D is likely stronger than was is used in this analysis (Piratheepan et al., 2013).
    - a. Unit weight of the C&D waste was estimated from site tonnage information made available to us by Alliance Consulting Engineers.
  9. The following cross sections were analyzed for slope stability:
    - a. **A-A'** represents the final grades of the south facing slope of Expansion Area A. The cross section represents the thickest portion of waste above base grades that slope to the south. The slope consists of 3:1 H:V sections with 45 feet wide benches at 25 feet vertical spacing, for an overall slope inclination of 4.1:1 H:V.
    - b. **B-B'** represents the final grades of the east facing slope of Expansion Area A. A planned sediment pond is located at the toe of slope. The slope consists of 3:1 H:V sections with 45 feet wide benches at 25 feet vertical spacing, for an overall slope inclination of 4.1:1 H:V.
    - c. **C-C'** represents the final grades of the southeast facing slope of Expansion Area B, and represents the thickest portion of the waste mound in Expansion Area B. A planned sediment pond is located at the toe of slope. The slope consists of 4.25:1 H:V sections with 45 feet wide benches at 25 feet vertical spacing, for an overall slope inclination of 6:1 H:V.

### Assumptions

1. Slope stability analysis was performed for the final planned landfill grades. The analysis assumes long term drained conditions.
2. The analysis assumes proper bonding between C&D waste and soil subgrades, and between all C&D waste fills.
  - a. Suitable bonding of the C&D wastes assumes the waste has been keyed into the existing waste materials through benching of the existing waste surfaces, and that



- softened or weathered waste cover soils have been stripped prior to waste placement.
- b. Prior to the placement of C&D wastes above the soil subgrade, the soil subgrade is to be maintained in its final constructed condition (e.g. well compacted, without excess moisture or softening due to moisture) until C&D waste is placed.
    - a. Placement of the C&D waste is assumed to occur in a “bottom up” manner of placement, with the waste placed at the bottom of the Cell and placed in subsequent overlying benches. Waste is placed starting from the lowest elevation of each cell then working upward in horizontal lifts. Downhill placement and compaction of the waste was not considered in this analysis and is not a recommended method of placement.
    - c. Storm water is not allowed to pond over portions of the landfill.
    - d. Intermediate landfill slopes should not terminate (toe out) in the cell floor, but rather the toe of the waste slope should be at the edge of the landfill cell/section.
    - e. Failure to properly place, compact, and maintain the waste mound could result in lower factors of safety than those calculated in this analysis and therefore lead to instability.
  3. The analysis assumes the C&D waste is fully draining, and does not have a piezometric head within the waste.
  4. For cross sections that included sediment ponds at the toe of the slopes, the factor of safety was calculated for the condition of an empty pond (drawdown condition).
  5. The analysis was performed using SLOPE/W of the GeoStudio 2019 R2 software package (2019 Release, Version 10.1.0.18696) developed by GEO-SLOPE International. The analysis used the Morgenstern-Price method of slices for limit equilibrium, using an Entry/Exit (circular failure) or block specified (block failure) slip surface search criteria. An iterative optimization search procedure was then performed, which provided an optimized composite failure surface. In general, the program calculates the factor of safety for potential slip surfaces from the ratio of available shear resistance and the shear resistance required to provide equilibrium.

Table 1 outlines the estimated Mohr-Coulomb shear strength envelopes utilized for the various materials and conditions.



**Table 1: Material Parameters (Long Term Drained)**

<b>Material</b>	<b>Unit Weight (pcf)</b>	<b>Friction Angle, <math>\phi</math> (°)</b>	<b>Cohesion, c (psf)</b>
Bedrock	Impenetrable		
Deep Residual Soils (Stiff/Firm Silty Sands)	124	30	0
Near Surface Residual Soils (Loose Sandy Silts & Silty Sands)	117	28	0
Structural Fill	115	32	0
C&D Waste	60	30	200



### SUMMARY OF RESULTS

The following tables summarizes the minimum slope stability factors of safety results for the cross sections analyzed:

**Table 2: Minimum Slope Stability Factors of Safety for Cross Sections**

MODEL NAME	RUN NO.	FAILURE LOCATION	FAILURE SHAPE	LOWEST MINIMUM F.S.
<b>A-A'- Expansion Area A South Slope</b>				
South Slope	1.A.2	C&D Waste & Shallow Residual Soils	Block, Optimized	3.3
South Slope – Global	1.B.1	Global, Shallow Residual Soils	Circular, Optimized	3.2
South Slope – Global, Outer Slope	1.C.1	C&D Waste & Shallow Residual Soils	Circular, Optimized	3.1
<b>B-B'- Expansion Area A East Slope</b>				
East Slope	2.A.1	C&D Waste & Shallow Residual Soils Interface	Circular, Optimized	3.2
East Slope – Global	2.B.1	Global, Interface of Shallow and Deep Residual Soils	Circular, Optimized	3.2
East Slope – Global, Outer Slope	2.C.1	C&D Waste & Shallow Residual Soils Interface	Circular, Optimized	2.9
East Slope – Global, Outer Slope Drawdown	2.C.3	C&D Waste & Shallow Residual Soils Interface	Circular, Optimized	2.9
<b>C-C'- Expansion Area B Southeast Slope</b>				
Southeast Slope	3.A.1	C&D Waste & Shallow Residual Soils	Circular, Optimized	4.6
Southeast Slope – Global	3.B.1	Global, Shallow Residual Soils	Circular, Optimized	3.4
Southeast Slope – Global, Outer Slope	3.C.1	Global, Shallow Residual Soils	Circular, Optimized	3.4
Southeast Slope – Global, Outer Slope Drawdown	3.C.4	Global, Shallow Residual Soils	Block, Optimized	3.2





The proposed final waste grades for Expansion A area consisting of 3:1 H:V slopes with intermediate benches represented by south and east slope cross sections A-A' and B-B' achieved the minimum recommended F.S.  $\geq 1.5$  under the assumptions for optimized circular and block failures.

The proposed Expansion B area final waste grades of the C&D waste slope represented by southeast cross section C-C' achieved the minimum recommended F.S.  $\geq 1.5$  under the assumptions for optimized circular and block failures.

## CONCLUSION

A global slope stability analysis was performed for the base grades, proposed final C&D waste slopes of Expansion A and Expansion B at the Greenpointe Class 2 Landfill. The analysis used the provided base and final grades prepared by Alliance Consulting Engineers.

The recommended static factor of safety of F.S.  $\geq 1.5$  was achieved for the planned final waste slope conditions.

These factors of safety are contingent upon the conditions included in this analysis and presented in our geotechnical report. The analysis was performed using the provided plans and grades. Any deviation from the fill plan related to the waste slope benching, toe of waste location, and steepened waste slopes should be re-evaluated by BLE.

## REFERENCES

- Bunnell-Lammons Engineering. (2019). *Site Hydrogeologic Characterization Report - Expansion Area (for) Greenpointe Class 2 Landfill*. Greenville, SC: Bunnell-Lammons Engineering.
- Davis & Floyd, Inc. (2008). *Construction, Demolition, and Land Clearing Debris Landfill Plan for the Greenpointe C&D Landfill Site*. Greenwood, South Carolina: Davis & Floyd, Inc.
- Department of the Navy, Naval Facilities Engineering Command (NAVFAC). (1982). *NAVFAC DM- 7.1, Soil Mechanics*. Alexandria, VA: NAVFAC.
- Duncan, J. M., Wright, S. G., & Brandon, T. L. (2014). *Soil Strength and Slope Stability, 2nd Edition*. New Jersey: John Wiley & Sons, Inc.
- GEO-SLOPE International. (2019, July). *GeoStudio 2019 R2, 2019 Release, Version 10.1.0.18696*. Calgary, Alberta, Canada.
- Piratheepan, J., Arulrajah, A., & Disfani, M. M. (2013). Large-Scale Direct Shear Testing of Recycled Construction and Demolition Materials. *Advances in Civil Engineering Materials*, 2(1), 25-36.
- QORE Property Sciences, Inc. (2005). *Report of Limited Geotechnical Exploration (for) WASTECO C&D Landfill*. Greenville, SC: QORE Property Sciences, Inc.
- US Army Corps of Engineers. (2003). *Engineering and Design: Slope Stability EM 1110-2-1902*.

## **SLOPE STABILITY ANALYSIS PRINTOUTS**



Title: Greenpointe Landfill - Expansion Area A  
 File Name: A-A' EX C&D Expansion.gsz  
 Comments: Existing C&D Waste Mound, Expansion Area A Lateral and Vertical Expansion - South Slope  
 Created By: Larry Simonson  
 Date: 08/06/2019  
 Tool Version: 10.1.0.18696

Name: 1.A.2 - South Slope  
 Description: Waste Slope (Block)  
 Method: Morgenstern-Price  
 Slip Surface Option: Block  
 Optimize Critical Slip Surface Location: Yes

Color	Name	Model	Unit Weight (pcf)	Cohesion' (psf)	Phi' (°)	Piezometric Line
Grey	Bedrock	Bedrock (Impenetrable)				1
Yellow	C&D Waste	Mohr-Coulomb	60	200	30	
Orange	Near Surface Sandy Silts and Silty Sands	Mohr-Coulomb	117	0	28	1
Blue	Stiff Silty Sands	Mohr-Coulomb	124	0	30	1
Cyan	Structural Fill	Mohr-Coulomb	115	0	32	1

3.3

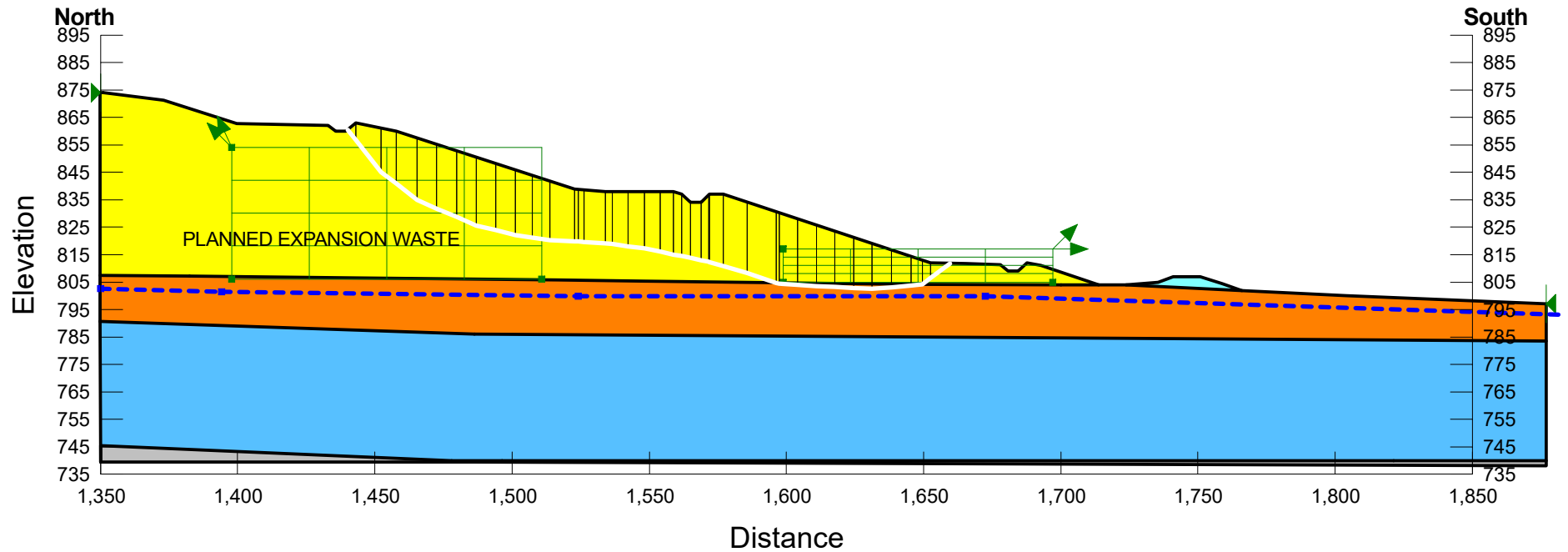



Title: Greenpointe Landfill - Expansion Area A  
 File Name: A-A' EX C&D Expansion.gsz  
 Comments: Existing C&D Waste Mound, Expansion Area A Lateral and Vertical Expansion - South Slope  
 Created By: Larry Simonson  
 Date: 08/06/2019  
 Tool Version: 10.1.0.18696

Name: 1.B.1 - South Slope-Global  
 Description: Global, Deep Seated  
 Method: Morgenstern-Price  
 Slip Surface Option: Entry and Exit  
 Optimize Critical Slip Surface Location: Yes

Color	Name	Model	Unit Weight (pcf)	Cohesion' (psf)	Phi' (°)	Piezometric Line
Grey	Bedrock	Bedrock (Impenetrable)				1
Yellow	C&D Waste	Mohr-Coulomb	60	200	30	
Orange	Near Surface Sandy Silts and Silty Sands	Mohr-Coulomb	117	0	28	1
Blue	Stiff Silty Sands	Mohr-Coulomb	124	0	30	1
Cyan	Structural Fill	Mohr-Coulomb	115	0	32	1

3.2

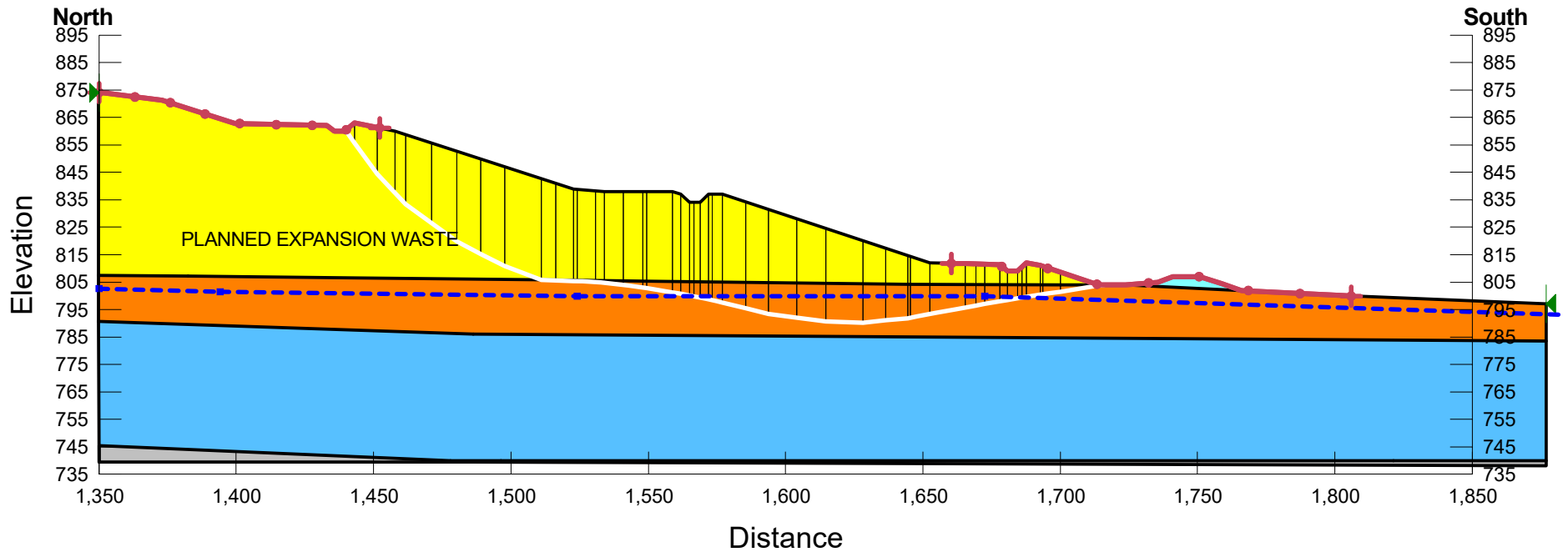



Title: Greenpointe Landfill - Expansion Area A  
File Name: A-A' EX C&D Expansion.gsz  
Comments: Existing C&D Waste Mound, Expansion Area A Lateral and Vertical Expansion - South Slope  
Created By: Larry Simonson  
Date: 08/06/2019  
Tool Version: 10.1.0.18696

Name: 1.C.1 - South Slope-Global, Outer Slope  
Description: Global, Deep Seated of Outer Slope  
Method: Morgenstern-Price  
Slip Surface Option: Entry and Exit  
Optimize Critical Slip Surface Location: Yes

Color	Name	Model	Unit Weight (pcf)	Cohesion' (psf)	Phi' (°)	Piezometric Line
Grey	Bedrock	Bedrock (Impenetrable)				1
Yellow	C&D Waste	Mohr-Coulomb	60	200	30	
Orange	Near Surface Sandy Silts and Silty Sands	Mohr-Coulomb	117	0	28	1
Blue	Stiff Silty Sands	Mohr-Coulomb	124	0	30	1
Cyan	Structural Fill	Mohr-Coulomb	115	0	32	1

3.1

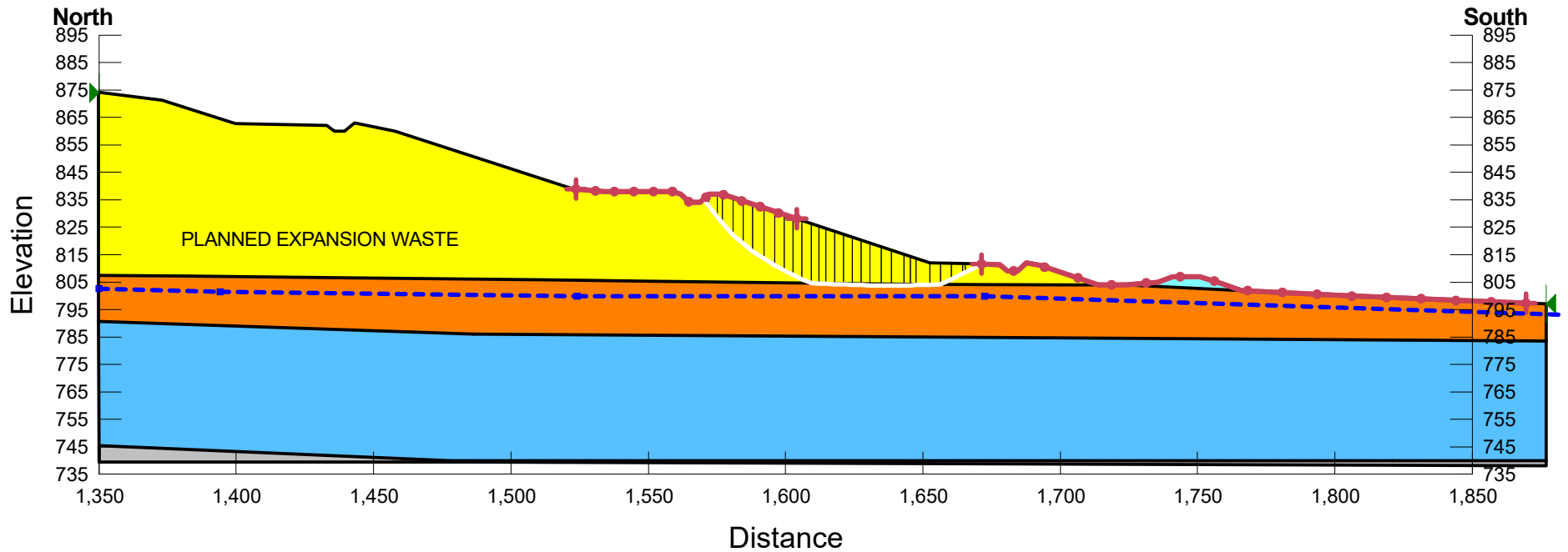



Title: Greenpointe Landfill - Expansion Area A  
 File Name: B-B' EX C&D Expansion.gsz  
 Comments: Existing C&D Waste Mound, Expansion Area A Lateral and Vertical Expansion - East Slope  
 Created By: Larry Simonson  
 Date: 08/06/2019  
 Tool Version: 10.1.0.18696

Name: 2.A.1 - East Slope  
 Description: Waste Slope  
 Method: Morgenstern-Price  
 Slip Surface Option: Entry and Exit  
 Optimize Critical Slip Surface Location: Yes

Color	Name	Model	Unit Weight (pcf)	Cohesion' (psf)	Phi' (°)	Piezometric Line
Grey	Bedrock	Bedrock (Impenetrable)				1
Yellow	C&D Waste	Mohr-Coulomb	60	200	30	1
Orange	Near Surface Sandy Silts and Silty Sands	Mohr-Coulomb	117	0	28	1
Blue	Stiff Silty Sands	Mohr-Coulomb	124	0	30	1

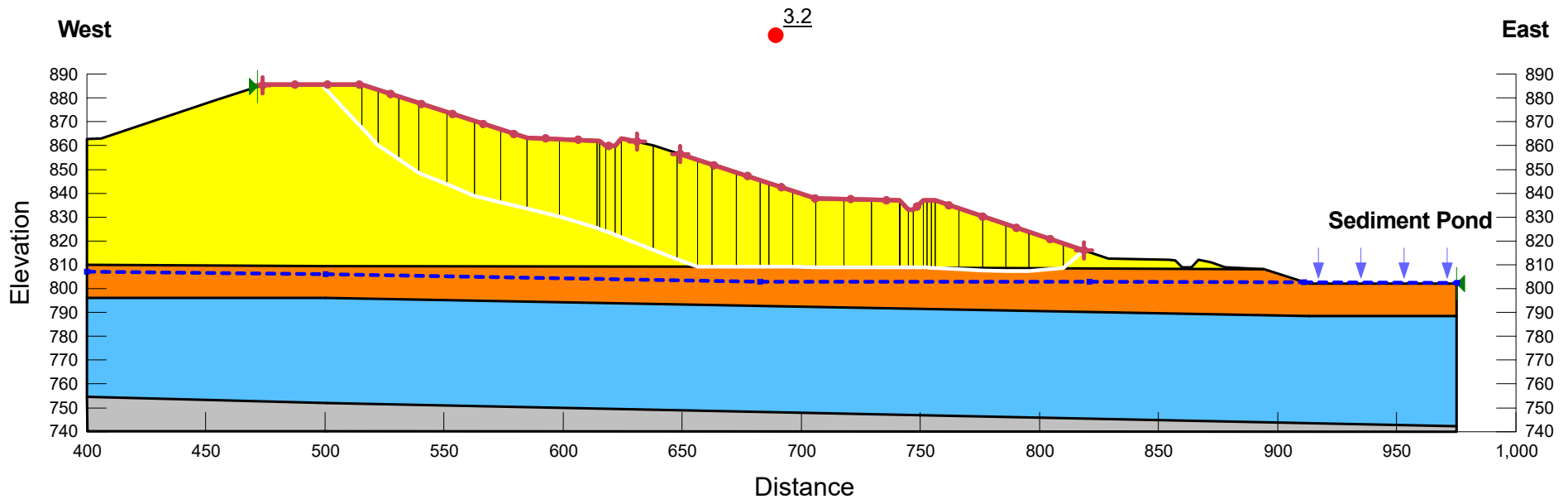



Title: Greenpointe Landfill - Expansion Area A  
 File Name: B-B' EX C&D Expansion.gsz  
 Comments: Existing C&D Waste Mound, Expansion Area A Lateral and Vertical Expansion - East Slope  
 Created By: Larry Simonson  
 Date: 08/06/2019  
 Tool Version: 10.1.0.18696

Name: 2.B.1 - East Slope - Global  
 Description: Global, Deep Seated  
 Method: Morgenstern-Price  
 Slip Surface Option: Entry and Exit  
 Optimize Critical Slip Surface Location: Yes

Color	Name	Model	Unit Weight (pcf)	Cohesion' (psf)	Phi' (°)	Piezometric Line
Grey	Bedrock	Bedrock (Impenetrable)				1
Yellow	C&D Waste	Mohr-Coulomb	60	200	30	1
Orange	Near Surface Sandy Silts and Silty Sands	Mohr-Coulomb	117	0	28	1
Blue	Stiff Silty Sands	Mohr-Coulomb	124	0	30	1

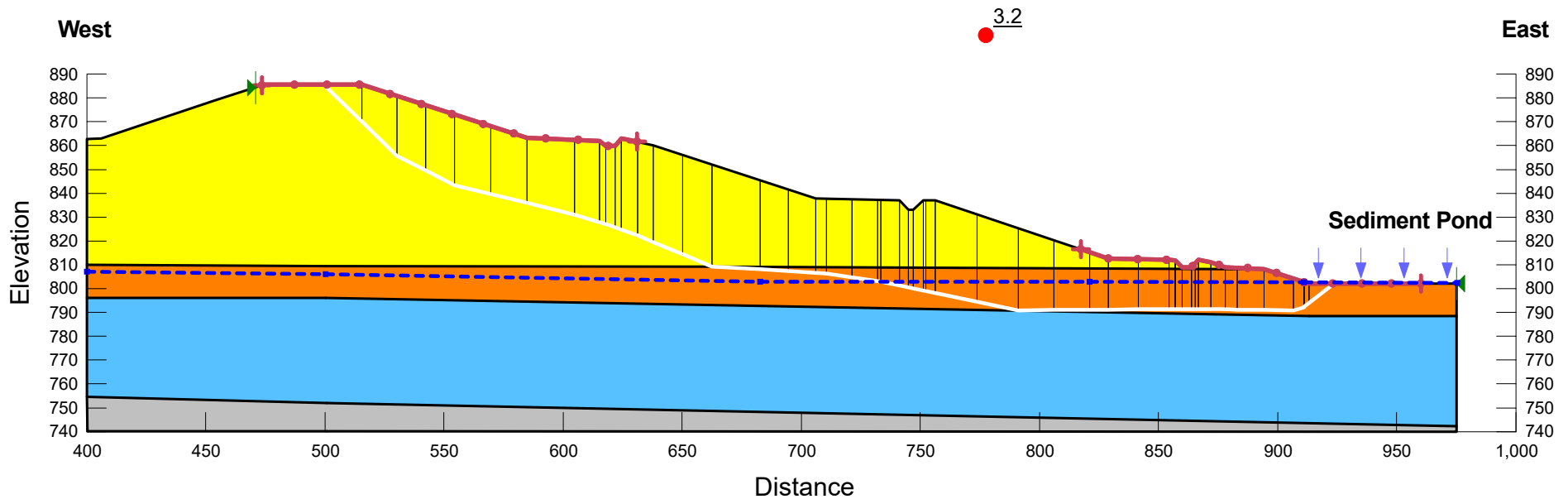



Title: Greenpointe Landfill - Expansion Area A  
 File Name: B-B' EX C&D Expansion.gsz  
 Comments: Existing C&D Waste Mound, Expansion Area A Lateral and Vertical Expansion - East Slope  
 Created By: Larry Simonson  
 Date: 08/06/2019  
 Tool Version: 10.1.0.18696

Name: 2.C.1 - East Slope - Global, Outer Slope  
 Description: Global, Deep Seated of Outer Slope  
 Method: Morgenstern-Price  
 Slip Surface Option: Entry and Exit  
 Optimize Critical Slip Surface Location: Yes

Color	Name	Model	Unit Weight (pcf)	Cohesion' (psf)	Phi' (°)	Piezometric Line
Grey	Bedrock	Bedrock (Impenetrable)				1
Yellow	C&D Waste	Mohr-Coulomb	60	200	30	1
Orange	Near Surface Sandy Silts and Silty Sands	Mohr-Coulomb	117	0	28	1
Blue	Stiff Silty Sands	Mohr-Coulomb	124	0	30	1

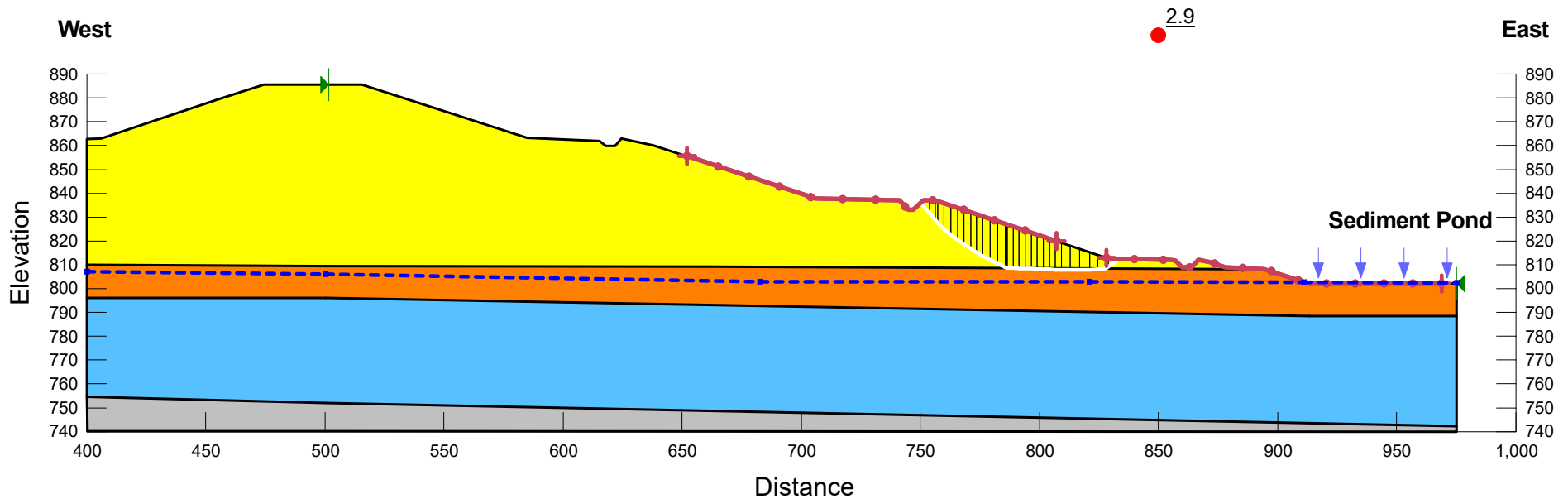





Title: Greenpointe Landfill - Expansion Area A  
 File Name: B-B' EX C&D Expansion.gsz  
 Comments: Existing C&D Waste Mound, Expansion Area A Lateral and Vertical Expansion - East Slope  
 Created By: Larry Simonson  
 Date: 08/06/2019  
 Tool Version: 10.1.0.18696

Name: 2.C.3 - East Slope - Global, Outer Slope Drawdown  
 Description: Global, Deep Seated of Outer Slope, Drawdown (Empty Pond)  
 Method: Morgenstern-Price  
 Slip Surface Option: Entry and Exit  
 Optimize Critical Slip Surface Location: Yes

Color	Name	Model	Unit Weight (pcf)	Cohesion' (psf)	Phi' (°)	Piezometric Line
Grey	Bedrock	Bedrock (Impenetrable)				1
Yellow	C&D Waste	Mohr-Coulomb	60	200	30	1
Orange	Near Surface Sandy Silts and Silty Sands	Mohr-Coulomb	117	0	28	1
Blue	Stiff Silty Sands	Mohr-Coulomb	124	0	30	1

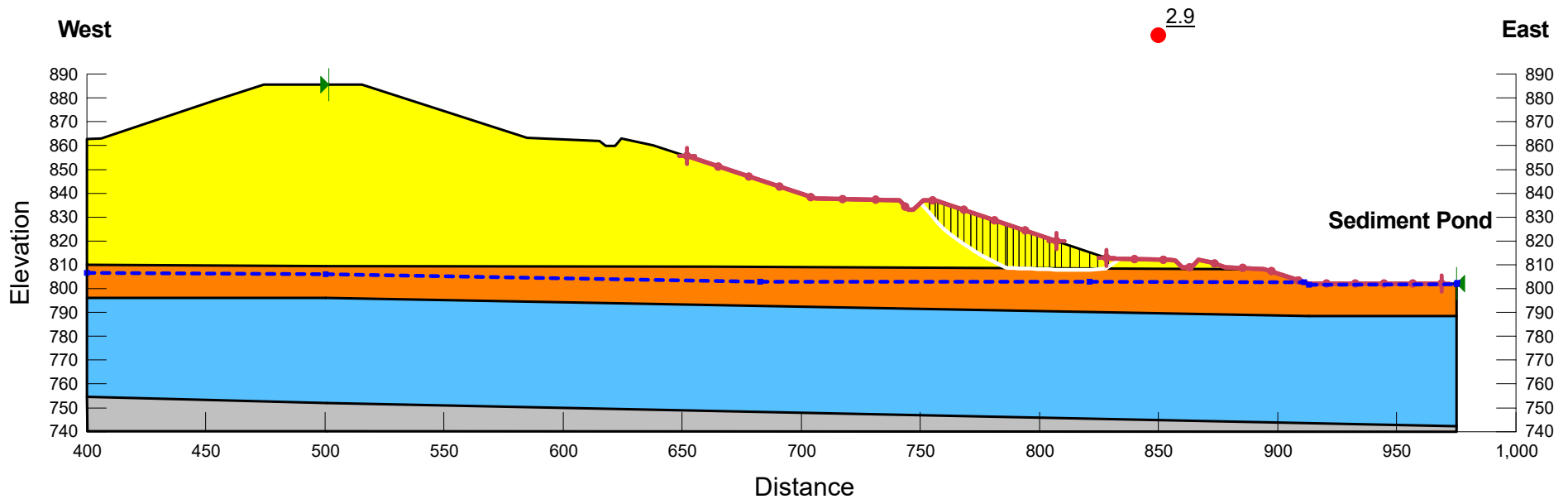



Title: Greenpointe Landfill - Expansion Area B  
 File Name: C-C' F C&D Expansion.gsz  
 Comments: Future C&D Waste Mound, Expansion Area B Lateral and Vertical Expansion - Southeast Slope  
 Created By: Larry Simonson  
 Date: 08/06/2019  
 Tool Version: 10.1.0.18696

Name: 3.A.1 - Southeast Slope  
 Description: Waste Slope  
 Method: Morgenstern-Price  
 Slip Surface Option: Entry and Exit  
 Optimize Critical Slip Surface Location: Yes

Color	Name	Model	Unit Weight (pcf)	Cohesion' (psf)	Phi' (°)	Piezometric Line
Grey	Bedrock	Bedrock (Impenetrable)				1
Yellow	C&D Waste	Mohr-Coulomb	60	200	30	1
Orange	Near Surface Sandy Silts and Silty Sands	Mohr-Coulomb	117	0	28	1
Blue	Stiff Silty Sands	Mohr-Coulomb	124	0	30	1

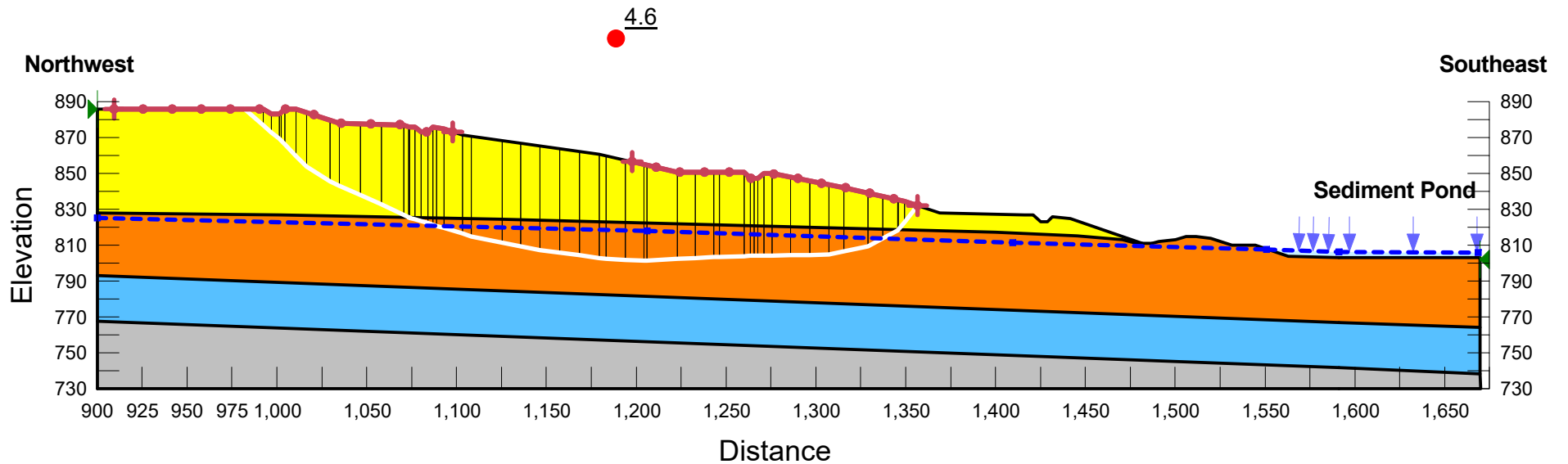



Title: Greenpointe Landfill - Expansion Area B  
 File Name: C-C' F C&D Expansion.gsz  
 Comments: Future C&D Waste Mound, Expansion Area B Lateral and Vertical Expansion - Southeast Slope  
 Created By: Larry Simonson  
 Date: 08/06/2019  
 Tool Version: 10.1.0.18696

Name: 3.B.1 - Southeast Slope-Global  
 Description: Global, Deep Seated  
 Method: Morgenstern-Price  
 Slip Surface Option: Entry and Exit  
 Optimize Critical Slip Surface Location: Yes

Color	Name	Model	Unit Weight (pcf)	Cohesion' (psf)	Phi' (°)	Piezometric Line
Grey	Bedrock	Bedrock (Impenetrable)				1
Yellow	C&D Waste	Mohr-Coulomb	60	200	30	1
Orange	Near Surface Sandy Silts and Silty Sands	Mohr-Coulomb	117	0	28	1
Blue	Stiff Silty Sands	Mohr-Coulomb	124	0	30	1

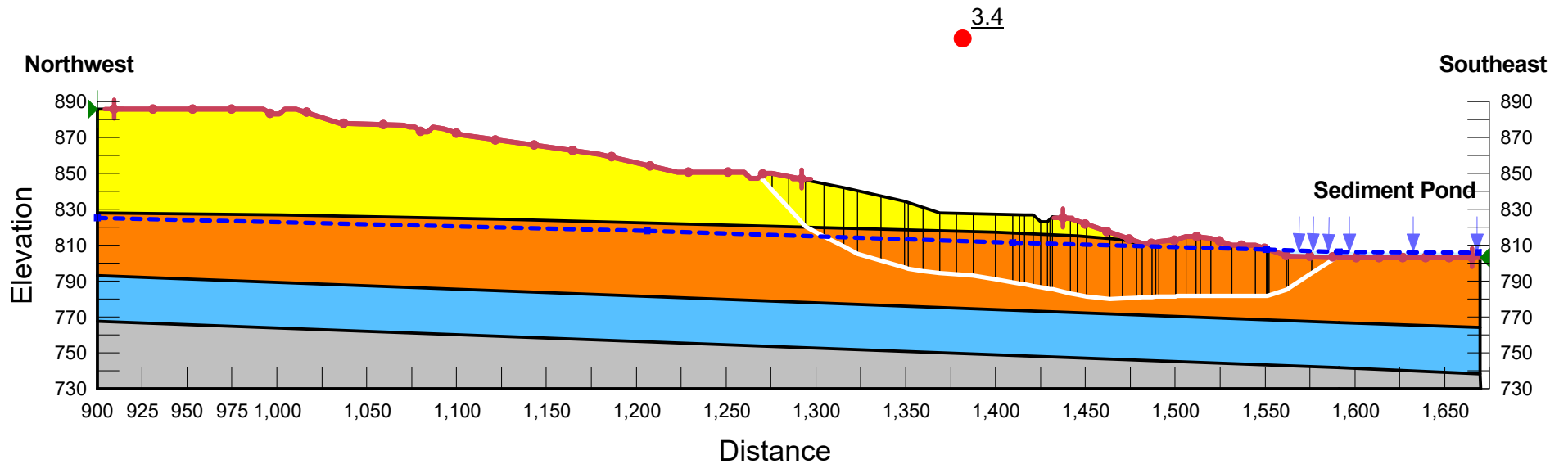



Title: Greenpointe Landfill - Expansion Area B  
 File Name: C-C' F C&D Expansion.gsz  
 Comments: Future C&D Waste Mound, Expansion Area B Lateral and Vertical Expansion - Southeast Slope  
 Created By: Larry Simonson  
 Date: 08/06/2019  
 Tool Version: 10.1.0.18696

Name: 3.C.1 - Southeast Slope-Global, Outer Slope  
 Description: Global, Deep Seated of Outer Slope  
 Method: Morgenstern-Price  
 Slip Surface Option: Entry and Exit  
 Optimize Critical Slip Surface Location: Yes

Color	Name	Model	Unit Weight (pcf)	Cohesion' (psf)	Phi' (°)	Piezometric Line
Grey	Bedrock	Bedrock (Impenetrable)				1
Yellow	C&D Waste	Mohr-Coulomb	60	200	30	1
Orange	Near Surface Sandy Silts and Silty Sands	Mohr-Coulomb	117	0	28	1
Blue	Stiff Silty Sands	Mohr-Coulomb	124	0	30	1

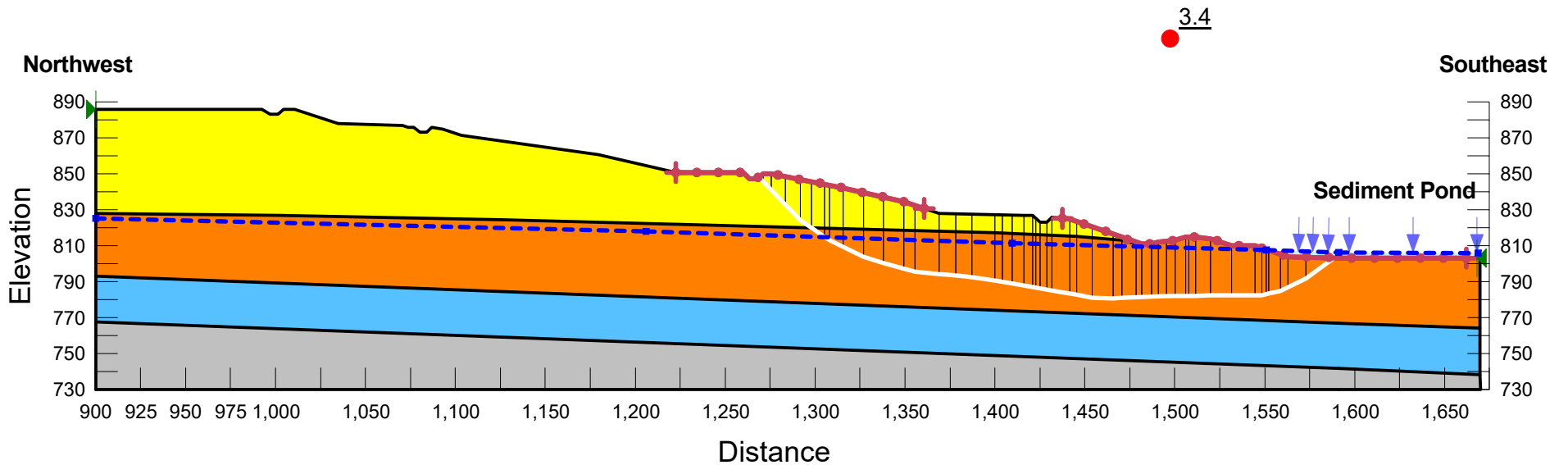



Title: Greenpointe Landfill - Expansion Area B  
 File Name: C-C' F C&D Expansion.gsz  
 Comments: Future C&D Waste Mound, Expansion Area B Lateral and Vertical Expansion - Southeast Slope  
 Created By: Larry Simonson  
 Date: 08/06/2019  
 Tool Version: 10.1.0.18696

Name: 3.C.4 - Southeast Slope-Global, Outer Slope Drawdown  
 Description: Global, Deep Seated of Outer Slope (Block)  
 Method: Morgenstern-Price  
 Slip Surface Option: Block  
 Optimize Critical Slip Surface Location: Yes

Color	Name	Model	Unit Weight (pcf)	Cohesion' (psf)	Phi' (°)	Piezometric Line
Grey	Bedrock	Bedrock (Impenetrable)				1
Yellow	C&D Waste	Mohr-Coulomb	60	200	30	1
Orange	Near Surface Sandy Silts and Silty Sands	Mohr-Coulomb	117	0	28	1
Blue	Stiff Silty Sands	Mohr-Coulomb	124	0	30	1

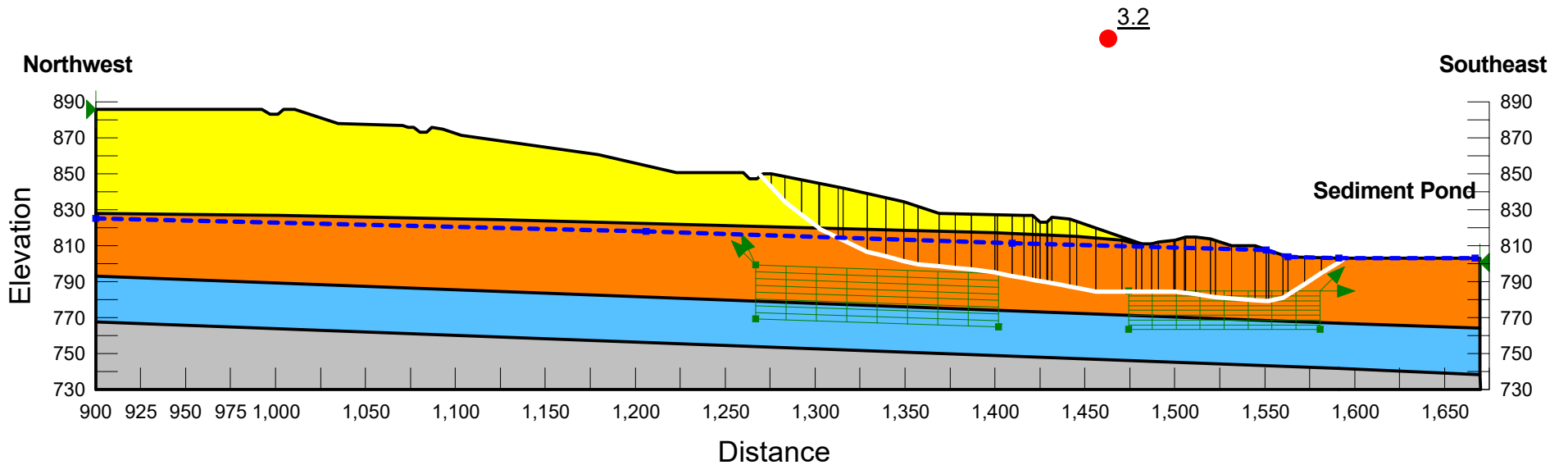

## **APPENDIX C**

### **SUBGRADE SETTLEMENT / GROUNDWATER SEPARATION WITH C&D WASTE SUBGRADE**

**SURCHARGE DETERMINATION  
SETTLEMENT CALCULATIONS  
PROPOSED LANDFILL EXPANSION**

GREENPOINTE CLASS II LANDFILL  
ANDERSON COUNTY, SOUTH CAROLINA

BLE Project No. J18-11684-02  
August 2019

Calculation Point	Location Within Cell	Station on Alignment  Feet	Representative Boring	Ground Elevation at Location  Feet	Elevation of Landfill Base Grade  Feet	Elevation Finished Cap  Feet	Fill Depth to Landfill Base Grade Fill (+) Cut (-) Feet	Layer Thickness		Net Surcharge Pressure at Landfill Base Grade  PSF
								C&D Debris  Feet	Cap  Feet	
SP-1	Expansion Area "A"	11+00 (A-A')	B-2	812.5	810.7	886.7	-1.8	74.0	2.0	4,463
SP-2	Expansion Area "A"	14+00 (A-A')	B-4	811.3	807.0	863.0	-4.3	54.0	2.0	2,971
SP-3	Expansion Area "A"	N/A	B-1	838.0	830.7	885.9	-7.3	53.2	2.0	2,572
SP-4	Expansion Area "A"	N/A	B-3	825.0	828.0	889.7	3.0	59.7	2.0	4,169
SP-5	Expansion Area "B"	5+00 (C-C')	PZ-21	832.3	833.5	877.2	1.2	41.7	2.0	2,876
SP-6	Expansion Area "B"	9+18 (C-C')	PZ-18	827.9	828.4	886.0	0.5	55.6	2.0	3,629
SP-7	Expansion Area "B"	13+12 (C-C')	PZ-25	830.2	819.7	842.9	-10.5	21.2	2.0	277

Net Surcharge = cap weight + weight of waste - net stress relief between original ground and landfill grade

Elevations from electronic drawing by Alliance Consulting Engineers dated June 24, 2019, revised August 8, 2019.

Assumed total unit weight of materials:

<b>C&amp;D Waste</b>	<b>60 pcf</b>
Structural Fill and Upper Residual Soil	117 pcf
Cap Soil	117 pcf

Calculated by:	Ross Robison, E.I.T.	8/8/2019
Checked by:	Tyler W. Moody, P.E.	8/8/2019
Reviewed by:	Daniel B. Bunnell, P.E.	8/8/2019

**SETTLEMENT CALCULATIONS**  
**GREENPOINTE CLASS II LANDFILL**  
**ANDERSON COUNTY, SOUTH CAROLINA**

Bunnell-Lammons Engineering, Inc. Project No. J18-11684-02

August 2019

Subsurface Layer	Layer Elevation (feet)	Layer Thickness (feet)	Standard Penetration Resistance N-Value (bpf)	Total Soil Unit Weight (pcf)	Effective Soil Unit Weight (pcf)	Surcharge Pressure <sup>1</sup> (psf)	Overburden Pressure at Mid-Point of Layer (psf)	Vertical Pressure at Mid-Point of Layer (psf)	Consolidation Test Results				Soil Modulus  Es (ksf)	Layer Settlement  (inches)
									Pc (ksf)	Cr	Cc	e <sub>0</sub>		
<b>PROPOSED LANDFILL EXPANSION</b>														
<b>Point SP-1, Section A-A' Station 11+00 (B-2)</b>														
Stiff sandy SILT	810.7 - 800.7	10.0	14	117.0	117.0	4,463	585	5,048					230	1.4
Loose silty SAND	800.7 - 785.7	15.0	8	117.0	54.6	4,463	1,580	6,043					160	3.0
V. Firm silty SAND	785.7 - 771.7	14.0	23	124.0	61.6	4,463	2,420	6,884					320	1.4
V. Dense silty SAND	771.7 - 753.7	18.0	50	124.0	61.6	4,463	3,406	7,869					540	1.1
<b>Total</b>		<b>57.0</b>	<b>Feet</b>											
													<b>TOTAL SETTLEMENT (INCHES)</b>	<b>6.9</b>
													<b>TOTAL SETTLEMENT (FEET)</b>	<b>0.58</b>
<b>Point SP-2, Section A-A' Station 14+00 (B-4)</b>														
F. Firm silty SAND	807.0 - 799.3	7.7	28	117.0	117.0	2,572	450	3,022					370	0.4
Loose silty SAND	799.3 - 784.0	15.3	8	117.0	54.6	2,572	1,319	3,890					160	1.8
V. Dense SAND (PWR)	784.0 - 767.0	17.0	100	124.0	61.6	2,572	2,260	4,832					860	0.4
<b>Total</b>		<b>40.0</b>	<b>Feet</b>											
													<b>TOTAL SETTLEMENT (INCHES)</b>	<b>2.6</b>
													<b>TOTAL SETTLEMENT (FEET)</b>	<b>0.22</b>

Calculated by: Ross Robison, E.I.T                      8/8/2019  
Checked by: Tyler Moody, P.E.                              8/8/2019  
Reviewed by: Daniel B. Bunnell, P.E.                      8/8/2019



**SETTLEMENT CALCULATIONS**  
**GREENPOINTE CLASS II LANDFILL**  
**ANDERSON COUNTY, SOUTH CAROLINA**

Bunnell-Lammons Engineering, Inc. Project No. J18-11684-02

August 2019

Subsurface Layer	Layer Elevation  (feet)	Layer Thickness  (feet)	Standard Penetration Resistance N-Value  (bpf)	Total Soil Unit Weight  (pcf)	Effective Soil Unit Weight  (pcf)	Surcharge Pressure <sup>1</sup>  (psf)	Overburden Pressure at Mid-Point of Layer  (psf)	Vertical Pressure at Mid-Point of Layer  (psf)	Consolidation Test Results				Soil Modulus  Es  (ksf)	Layer Settlement  (inches)
									Pc  (ksf)	Cr	Cc	e <sub>0</sub>		
<b>PROPOSED LANDFILL EXPANSION</b>														
<b>Point SP-3 (B-1)</b>														
V. Firm silty SAND	830.7 - 822.5	8.2	21	117	117.0	2,572	480	3,052					310	0.5
Firm silty SAND	822.5 - 777.5	45.0	13	124	61.6	2,572	2,345	4,917					220	3.8
<b>Total</b>		<b>53.2</b>	<b>Feet</b>											
													<b>TOTAL SETTLEMENT (INCHES)</b>	<b>4.3</b>
													<b>TOTAL SETTLEMENT (FEET)</b>	<b>0.36</b>
<b>Point SP-4 (B-3)</b>														
Fill	828.0 - 825.0	3.0	n/a	117	117.0	4,169	176	4,344					240	0.4
V. Stiff sandy SILT	825.0 - 797.0	28.0	14	117	54.6	4,169	1,115	5,284					230	3.7
Firm silty SAND	797.0 - 765.0	32.0	14	117	54.6	4,169	2,753	6,922					230	4.2
<b>Total</b>		<b>63.0</b>	<b>Feet</b>											
													<b>TOTAL SETTLEMENT (INCHES)</b>	<b>8.3</b>
													<b>TOTAL SETTLEMENT (FEET)</b>	<b>0.69</b>

Calculated by:	Ross Robison, E.I.T	8/8/2019
Checked by:	Tyler Moody, P.E.	8/8/2019
Reviewed by:	Daniel B. Bunnell, P.E.	8/8/2019

**SETTLEMENT CALCULATIONS**  
**GREENPOINTE CLASS II LANDFILL**  
**ANDERSON COUNTY, SOUTH CAROLINA**

Bunnell-Lammons Engineering, Inc. Project No. J18-11684-02

August 2019

Subsurface Layer	Layer Elevation  (feet)	Layer Thickness  (feet)	Standard Penetration Resistance N-Value  (bpf)	Total Soil Unit Weight  (pcf)	Effective Soil Unit Weight  (pcf)	Surcharge Pressure <sup>1</sup>  (psf)	Overburden Pressure at Mid-Point of Layer  (psf)	Vertical Pressure at Mid-Point of Layer  (psf)	Consolidation Test Results				Soil Modulus  Es (ksf)	Layer Settlement  (inches)
									Pc (ksf)	Cr	Cc	e <sub>0</sub>		
<b>PROPOSED LANDFILL EXPANSION</b>														
<b>Point SP-5, Section C-C' Station 14+00 (PZ-21)</b>														
Stiff clayey SILT	833.5 - 826.8	6.7	11	117.0	117.0	2,876	392	3,268	0.75	0.022	0.192	0.806		5.7
V. loose clayey SAND	826.8 - 820.3	6.5	4	117.0	54.6	2,876	961	3,838					100	1.3
Loose-Firm silty SAND	820.3 - 802.3	18.0	8	117.0	54.6	2,876	1,630	4,507					160	2.3
Assumed Silty SAND	802.3 - 772.0	30.3	12	124.0	61.6	2,876	3,055	5,931					210	0.0
Total		<b>61.5</b>	<b>Feet</b>											
													<b>TOTAL SETTLEMENT (INCHES)</b>	<b>9.3</b>
													<b>TOTAL SETTLEMENT (FEET)</b>	<b>0.78</b>
<b>Point SP-6, Section C-C' Station 9+18.34 (PZ-18)</b>														
Stiff sandy CLAY	828.4 - 817.1	11.3	12	117.0	117.0	3,629	661	4,290	1.27	0.022	0.192	0.806		8.1
Soft to Firm sandy SILT	817.1 - 806.6	10.5	5	117.0	54.6	3,629	1,609	5,237	3.09	0.022	0.192	0.806		3.5
Loose silty SAND	806.6 - 788.6	18.0	7	117.0	54.6	3,629	2,387	6,015					150	3.1
Assumed silty SAND	788.6 - 768.3	20.3	12	124.0	61.6	3,629	3,503	7,132					210	2.5
Total		<b>60.1</b>	<b>Feet</b>											
													<b>TOTAL SETTLEMENT (INCHES)</b>	<b>17.2</b>
													<b>TOTAL SETTLEMENT (FEET)</b>	<b>1.43</b>

**SETTLEMENT CALCULATIONS**  
**GREENPOINTE CLASS II LANDFILL**  
**ANDERSON COUNTY, SOUTH CAROLINA**

Bunnell-Lammons Engineering, Inc. Project No. J18-11684-02

August 2019

Subsurface Layer	Layer Elevation  (feet)	Layer Thickness  (feet)	Standard Penetration Resistance N-Value  (bpf)	Total Soil Unit Weight  (pcf)	Effective Soil Unit Weight  (pcf)	Surcharge Pressure <sup>1</sup>  (psf)	Overburden Pressure at Mid-Point of Layer  (psf)	Vertical Pressure at Mid-Point of Layer  (psf)	Consolidation Test Results				Soil Modulus  Es (ksf)	Layer Settlement  (inches)	
									Pc (ksf)	Cr	Cc	e <sub>0</sub>			
<b>PROPOSED LANDFILL EXPANSION</b>															
<b>Point SP-7, Section C-C' Station 13+12 (PZ-25)</b>															
Firm silty SAND	819.7 - 813.2	6.5	13	117.0	117.0	277	380	658					220	0.1	
Loose silty SAND	813.2 - 794.2	19.0	7	117.0	54.6	277	1,279	1,557					150	0.3	
Dense SAND	794.2 - 768.7	25.5	15	124.0	61.6	277	2,583	2,861					240	0.2	
<b>Total</b>		<b>51.0</b>	<b>Feet</b>												
													<b>TOTAL SETTLEMENT (INCHES)</b>		<b>0.6</b>
													<b>TOTAL SETTLEMENT (FEET)</b>		<b>0.05</b>

Calculated by: Ross Robison, E.I.T.                      8/8/2019  
Checked by: Tyler Moody, P.E.                              8/8/2019  
Reviewed by: Daniel B. Bunnell, P.E.                      8/8/2019

# POST-SETTLEMENT LANDFILL SEPARATION

## PROPOSED LANDFILL EXPANSION GREENPOINTE CLASS II LANDFILL ANDERSON COUNTY, SOUTH CAROLINA

BLE Project No. J18-11684-02

Settlement Point	Location	Settlement of Landfill Base Grade Feet	Design Landfill Base Grade Elevation Feet	Seasonal High Groundwater Elevation from BLE (2019) Feet	Groundwater Separation with Design Landfill Base Grade Feet
SP-1	Section A-A' Station 11+00	0.58	810.70	807.50	2.63
SP-2	Section A-A' Station 14+00	0.22	807.00	801.40	5.38
SP-3	Offset A-A'	0.36	830.70	828.18	2.16
SP-4	Offset A-A'	0.69	828.03	822.51	4.83
SP-5	Section C-C' Station 14+00	0.78	833.50	829.90	2.82
SP-6	Section C-C' Station 9+18	1.43	828.40	824.90	2.07
SP-7	Section C-C' Station 13+12	0.05	819.70	814.70	4.95

Minimum required separation above the seasonal high groundwater is 2.0 feet.

Calculated by: Ross Robison 8/8/2019  
Checked by: Tyler Moody, P.E. 8/8/2019  
Reviewed by: Daniel B. Bunnell, P.E. 8/8/2019

## **APPENDIX D**

### **SOIL TEST BORING LOGS AND LABORATORY DATA**

# SOIL TEST BORING RECORD



BORING NO: **B-1**

PROJECT: WASTECO C&D Landfill	JOB NO: 7313	REPORT NO: 104641
PROJECT LOCATION: Anderson, South Carolina		
ELEVATION: 850 +/- Feet	BORING STARTED: 8/18/2005	BORING COMPLETED: 8/18/2005
DRILLING METHOD: Hollow Stem Auger	RIG TYPE: Acker ADII	HAMMER: Rope and Cathead
GROUNDWATER: Not Encountered	BORING DIAMETER (IN): 6	SHEET 1 OF 1

Remarks:

G	ELEV. (FT.)	DEPTH (FT.)	MATERIAL DESCRIPTION	L	S	STANDARD PENETRATION RESISTANCE (N)							BLOWS / 6"				
						1	10	20	30	40	50	70		100			
	850	0	Residuum - Very Stiff Reddish Brown and Yellowish Brown Sandy Silt (ML)		▲												
		5															8-9-11
	843	10	Very Firm to Firm Brown and Grayish Brown Micaceous to Very Micaceous Silty Fine to Medium Sand (Moist) (SM)		▲												
		15															9-11-10
		20															10-12-10
		25															5-6-5
		30															5-5-6
		35															6-7-9
	810	40	Boring Terminated		▲									6-6-7			
		45												5-7-6			
		50															

BORING\_RECORD\_7313.GPJ QOR\_CORP.GDT: 9/6/05

# SOIL TEST BORING RECORD



BORING NO: **B-2**

PROJECT: WASTECO C&D Landfill	JOB NO: 7313	REPORT NO: 104641
PROJECT LOCATION: Anderson, South Carolina		
ELEVATION: 812 +/- Feet	BORING STARTED: 8/18/2005	BORING COMPLETED: 8/18/2005
DRILLING METHOD: Hollow Stem Auger	RIG TYPE: Acker ADII	HAMMER: Rope and Cathead
GROUNDWATER: Not Encountered	BORING DIAMETER (IN): 6	SHEET 1 OF 2

Remarks:

G	ELEV. (FT.)	DEPTH (FT.)	MATERIAL DESCRIPTION	L	S	STANDARD PENETRATION RESISTANCE (N)						BLOWS /6"						
						1	10	20	30	40	50		70	100				
	812	0	6 Inches Topsoil															
		5	Residuum - Very Stiff to Firm Reddish Brown and Yellowish Brown Slightly Micaceous Sandy Silt (Moist) (ML)														9-9-9	
		10																3-7-9
		15																3-3-4
	795	20	Loose Light Brown, White and Gray Slightly Micaceous Silty Fine to Medium Sand (Moist) (SM)															3-4-3
		25																4-5-5
		30																7-8-13
	784	35	Very Firm Yellowish Brown Micaceous Silty Fine to Medium Sand (SM)															9-11-13
		40																3-12-12
		45																17-26-28
	770	50	Very Dense to Dense Brown and Gray Slightly Micaceous Silty Fine to Medium Sand (Moist) (SM)															14-22-27

BORING RECORD 7313.GPJ QOR\_CORP.GDT 9/8/05

# SOIL TEST BORING RECORD



BORING NO: **B-2**

PROJECT: WASTEKO C&D Landfill		JOB NO: 7313	REPORT NO: 104641
PROJECT LOCATION: Anderson, South Carolina			
ELEVATION: 812 +/- Feet	BORING STARTED: 8/18/2005		BORING COMPLETED: 8/18/2005
DRILLING METHOD: Hollow Stem Auger	RIG TYPE: Acker ADII	HAMMER: Rope and Cathead	
GROUNDWATER: Not Encountered	BORING DIAMETER (IN): 6	SHEET 2 OF 2	

Remarks:

G	ELEV. (FT.)	DEPTH (FT.)	MATERIAL DESCRIPTION	L	S	STANDARD PENETRATION RESISTANCE (N)						BLOWS / 6"		
						1	10	20	30	40	50		70	100
		50	Very Dense to Dense Brown and Gray Slightly Micaceous Silty Fine to Medium Sand (Moist) (SM) (Continued)	▬	▬									
		55												
	752	60	Boring Terminated											19-23-28
		65												
		70												
		75												
		80												
		85												
		90												
		95												
		100												

BORING RECORD 7313.GPJ QOR\_CORP.GDT 9/6/05



# SOIL TEST BORING RECORD



BORING NO: **B-3**

PROJECT: WASTECO C&D Landfill		JOB NO: 7313	REPORT NO: 104641
PROJECT LOCATION: Anderson, South Carolina			
ELEVATION: 818 +/- Feet	BORING STARTED: 8/18/2005		BORING COMPLETED: 8/18/2005
DRILLING METHOD: Hollow Stem Auger	RIG TYPE: Acker ADII	HAMMER: Rope and Cathead	
GROUNDWATER: Not Encountered	BORING DIAMETER (IN): 6		SHEET 1 OF 1

Remarks: Offset and Performed Auger Boring to 31-feet. Pushed tubes at 7-9 feet, 9-11 feet, 27-19 feet, and 29-31 feet.

G	ELEV. (FT.)	DEPTH (FT.)	MATERIAL DESCRIPTION	L	S	STANDARD PENETRATION RESISTANCE (N)										BLOWS / 6"	
						1	10	20	30	40	50	70	100				
	818	0	6 Inches Topsoil														
		5	Residuum - Very Stiff to Firm Yellowish Brown and Gray Sandy Silt (ML)														6-9-9
		10															3-4-4
	806	15		Stiff to Very Stiff Light Brown and White Slightly Micaceous Sandy Silt (Moist) (ML)													5-6-6
		20	Firm Brown, White, and Dark Brown Slightly Micaceous Silty Fine to Medium Sand (Very Moist) (SM)														6-9-10
		25															6-7-9
	790	30															5-7-7
		35															6-6-7
		40	Boring Terminated														5-6-8
		45															6-7-7
	768	50															5-6-7

BORING RECORD 7313.GPJ QOR\_CORP.GDT 9/6/05

# SOIL TEST BORING RECORD



BORING NO: **B-4**

PROJECT: WASTECO C&D Landfill	JOB NO: 7313	REPORT NO: 104641
PROJECT LOCATION: Anderson, South Carolina		
ELEVATION: 813 +/- Feet	BORING STARTED: 8/18/2005	BORING COMPLETED: 8/18/2005
DRILLING METHOD: Hollow Stem Auger	RIG TYPE: Acker ADII	HAMMER: Rope and Cathead
GROUNDWATER: Not Encountered	BORING DIAMETER (IN): 6	SHEET 1 OF 1

Remarks:

G	ELEV. (FT.)	DEPTH (FT.)	MATERIAL DESCRIPTION	L	S	STANDARD PENETRATION RESISTANCE (N)						BLOWS / 6"			
						1	10	20	30	40	50		70	100	
	813	0	6 Inches Topsoil												
		5	Residuum - Hard Yellowish Brown and Red Sandy Silt (ML)												9-14-18
	806	10	Very Firm Reddish Brown Silty Fine to Coarse Sand (SM)												10-12-12
	801	15	Loose to Firm Gray, White, and Brown Very Micaceous-Silty Fine to Medium Sand (Moist) (SM)												4-4-4
		20													3-2-4
		25													5-5-7
	786	30	Dense Brown and White Micaceous Silty Fine to Medium Sand (SM)												10-17-21
	780	35	Partially Weathered Rock - Sampled as Very Dense Brown, Gray, and White Micaceous Silty Fine to Medium Sand (PWR)												>> 34-50/5"
		40													>> 47-50/2"
	769	45	Auger Refusal Encountered at 44 Feet; Boring Terminated												>> 50/2"
		50													

BORING RECORD 7313.GPJ QOR\_CORP\_GDT 9/6/05



# CONSOLIDATION TEST REPORT

(ASTM D 2435)



REV0, 11/15/02

JOB NAME : WASTEKO C&D Landfill		CONTRACT NO. AB 80187N , SPECIFICATION K-SPC-G-00013 REV8	
JOB NO. : 7313	REPORT NO. : 104641	DATE : 9/6/2005	
BORING / PIT NO. : B-3	DEPTH / ELEV. : 7' - 9'	REVIEWED BY : <i>Kww</i>	
SAMPLE LOCATION : -			
WET DENSITY, $\gamma_{wet}$ , PCF : 116.3	DRY DENSITY, $\gamma_{DRY}$ , PCF : 92.3	SAMPLE TYPE : UD	
VOID RATIO, $e_o$ : 0.806	MOISTURE CONTENT, % : 26.0	SAMPLE NO. : -	
SATURATION, $S_o$ , % : 86.2	LOAD VS. TIME PLOT : Log of time	SP. GRAVITY, $G_s$ : 2.67	
LIQUID LIMIT, % : -	PLASTICITY INDEX, % : -	FINES, % : 55.9	
SOIL DESCRIPTION : Brownish Yellow and Light-Brown Sandy Lean Clay			
REMOVED PROPERTIES : -			

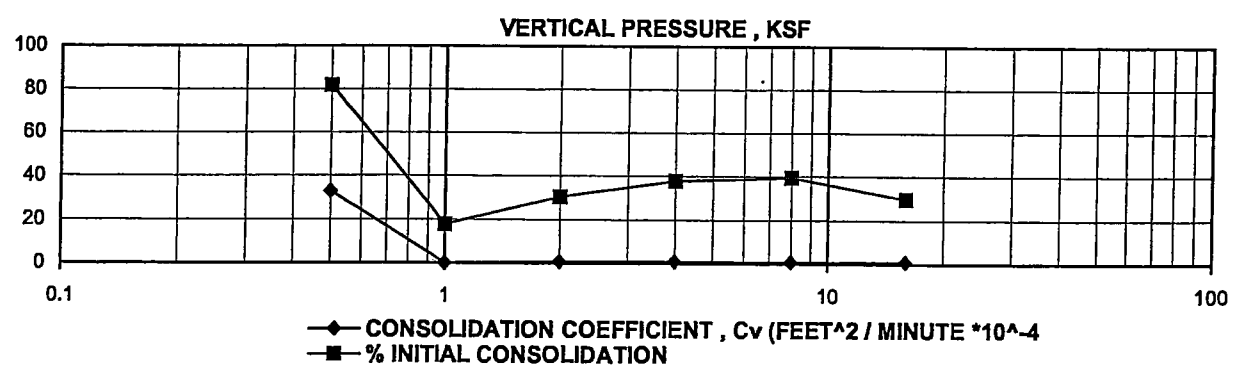
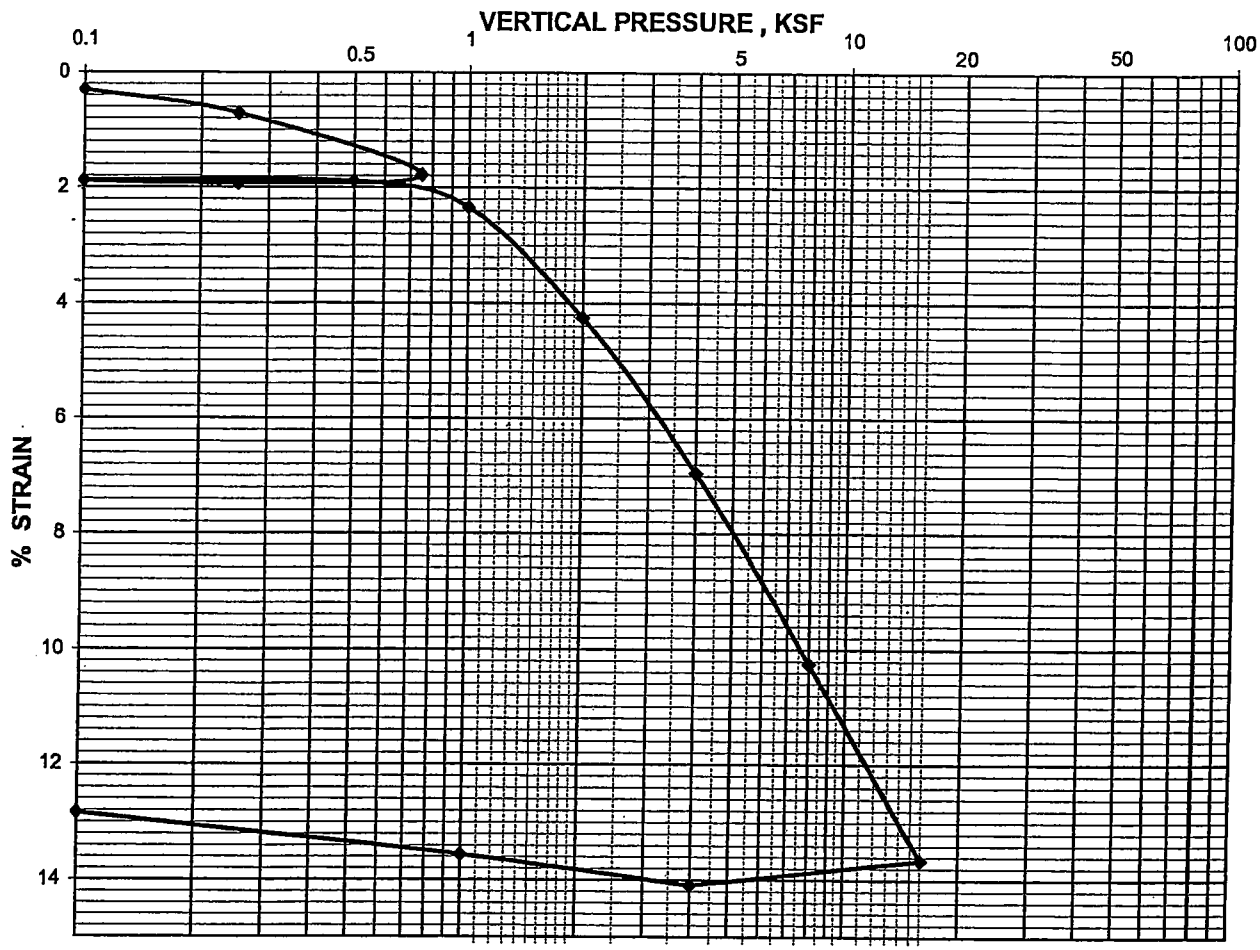

# CONSOLIDATION TEST REPORT

(ASTM D 2435)



REV0,11/15/02

JOB NAME : WASTEKO C&D Landfill		CONTRACT NO. AB 80187N , SPECIFICATION K-SPC-G-00013 REV8	
JOB NO. : 7313	REPORT NO. : 104641	DATE : 9/6/2005	
BORING / PIT NO. : B-3	DEPTH / ELEV. : 29' - 31'	REVIEWED BY : <i>K W W</i>	
SAMPLE LOCATION : -			
WET DENSITY, $\gamma_{wet}$ , PCF : 124.3	DRY DENSITY, $\gamma_{DRY}$ , PCF : 105.4	SAMPLE TYPE : UD	
VOID RATIO, $e_o$ : 0.545	MOISTURE CONTENT, % : 17.9	SAMPLE NO. : -	
SATURATION, $S_o$ , % : 85.8	LOAD VS. TIME PLOT : Log of time	SP. GRAVITY, $G_s$ : 2.61	
LIQUID LIMIT, % : -	PLASTICITY INDEX, % : -	FINES, % : 21.8	
SOIL DESCRIPTION : Yellowish Brown Silty Sand			
REMOLDED PROPERTIES : -			

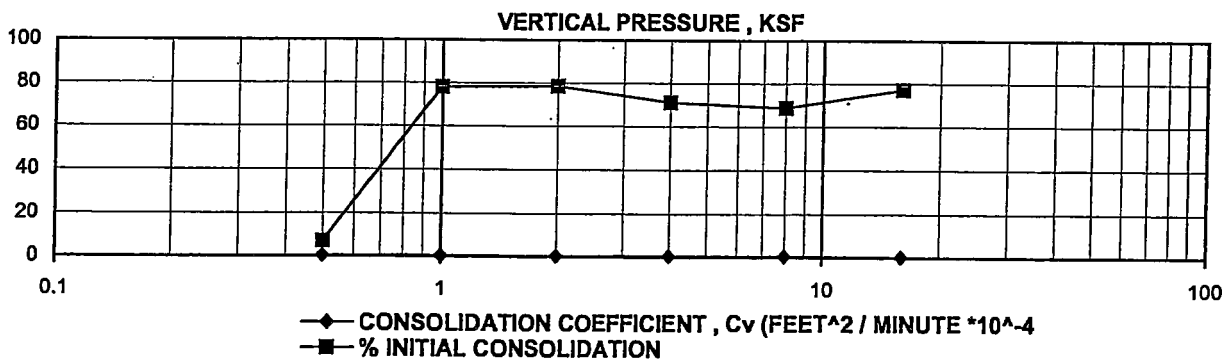
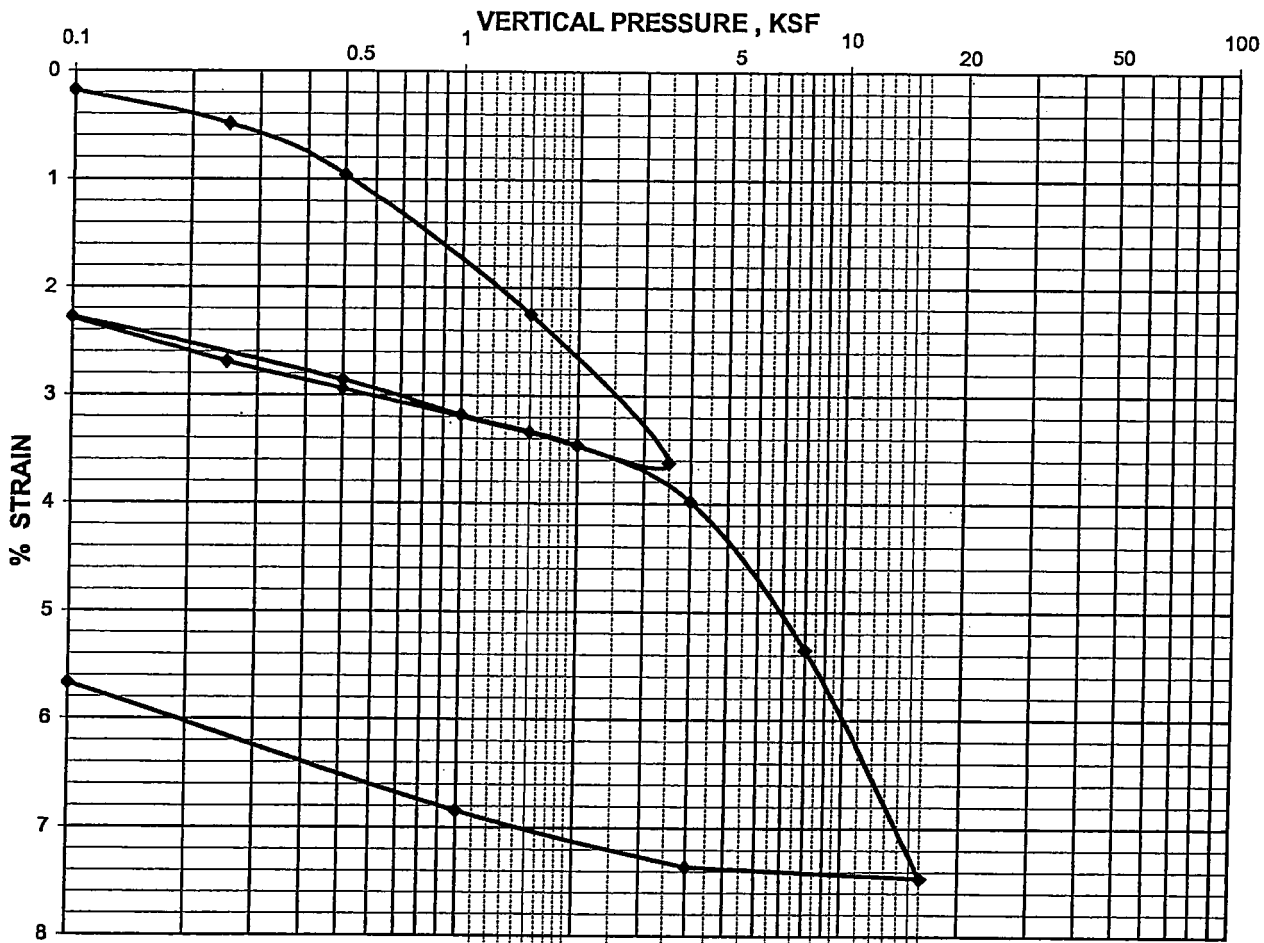

# KEY TO SOIL CLASSIFICATIONS AND CONSISTENCY DESCRIPTIONS

BUNNELL-LAMMONS ENGINEERING, INC.  
GREENVILLE, SOUTH CAROLINA

## Penetration Resistance\* Blows per Foot

SANDS

0 to 4  
5 to 10  
11 to 20  
21 to 30  
31 to 50  
over 50

## Relative Density

Very Loose  
Loose  
Firm  
Very Firm  
Dense  
Very Dense

## Particle Size Identification

Boulder: Greater than 300 mm  
Cobble: 75 to 300 mm  
Gravel:  
Coarse - 19 to 75 mm  
Fine - 4.75 to 19 mm  
Sand:  
Coarse - 2 to 4.75 mm  
Medium - 0.425 to 2 mm  
Fine - 0.075 to 0.425 mm  
Silt & Clay: Less than 0.075 mm

## Penetration Resistance\* Blows per Foot

SILTS and CLAYS

0 to 2  
3 to 4  
5 to 8  
9 to 15  
16 to 30  
31 to 50  
over 50

## Consistency

Very Soft  
Soft  
Firm  
Stiff  
Very Stiff  
Hard  
Very Hard

\*ASTM D 1586

## KEY TO DRILLING SYMBOLS



Grab Sample



Split Spoon Sample



Undisturbed Sample

NR = No reaction to HCL

NA = Not applicable

NS = No sample



Groundwater Table at Time of Drilling



Groundwater Table 24 Hours after Completion of Drilling

## KEY TO SOIL CLASSIFICATIONS



Well-graded Gravel  
GW

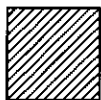

Low Plasticity Clay  
CL

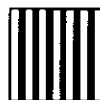

Clayey Silt  
MH

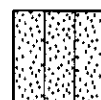

Silty Sand  
SM



Poorly-graded Gravel  
GP

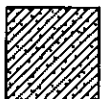

Sandy Clay  
CLS



Sandy Silt  
MLS



Topsoil  
TOPSOIL



Partially Weathered Rock  
BLDRCBBL

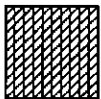

Silty Clay  
CL-ML

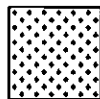

Sand  
SW

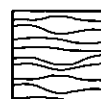

Liquid Sludge  
SLUDGE

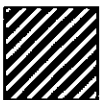

High Plasticity Clay  
CH

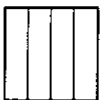

Silt  
ML

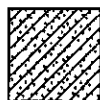

Clayey Sand  
SC

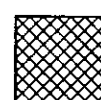

Fill  
FILL

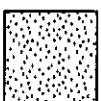

Poorly Graded Sand  
SP

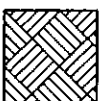

Bedrock  
BEDROCK

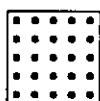

Waste  
WOOD



**BUNNELL-LAMMONS  
ENGINEERING, INC.**  
GEOTECHNICAL AND ENVIRONMENTAL  
CONSULTANTS

**GROUNDWATER MONITORING WELL NO. PZ-14**

PROJECT: Greenpointe Class 2 Landfill

PROJECT NO.: J17-11684-02

CLIENT: Greenpointe Landfill, LLC

START: 12-4-17 END: 12-4-17

LOCATION: Easley, South Carolina

ELEVATION: 822.99

DRILLER: Landprobe, R. Banks

LOGGED BY: R. Doherty

DRILLING METHOD: CME 750; 4-1/4 inch hollow stem auger

DEPTH TO - WATER> INITIAL: ▽ 1.5 AFTER 24 HOURS: ▽ 1.5 CAVING: ☒

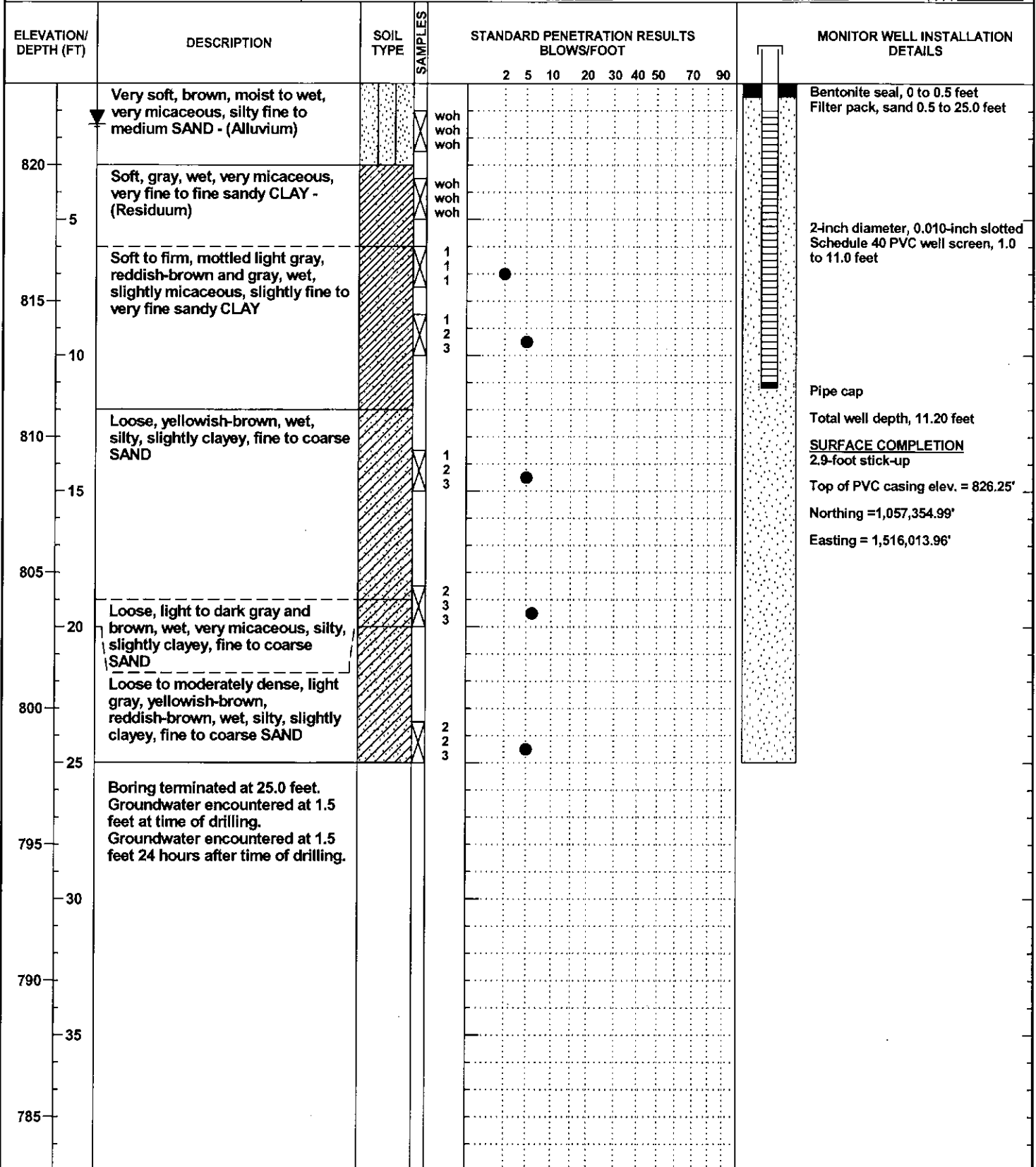



**BUNNELL-LAMMONS  
ENGINEERING, INC.**  
GEOTECHNICAL AND ENVIRONMENTAL  
CONSULTANTS

**GROUNDWATER MONITORING WELL NO. PZ-15**

PROJECT: Greenpointe Class 2 Landfill

PROJECT NO.: J17-11684-02

CLIENT: Greenpointe Landfill, LLC

START: 12-5-17 END: 12-5-17

LOCATION: Easley, South Carolina

ELEVATION: 813.03

DRILLER: Landprobe, R. Banks

LOGGED BY: R. Doherty

DRILLING METHOD: CME 750; 4-1/4 inch hollow stem auger

DEPTH TO - WATER> INITIAL: ▽ 2.7 AFTER 24 HOURS: ▽ 2.11 CAVING> ☒

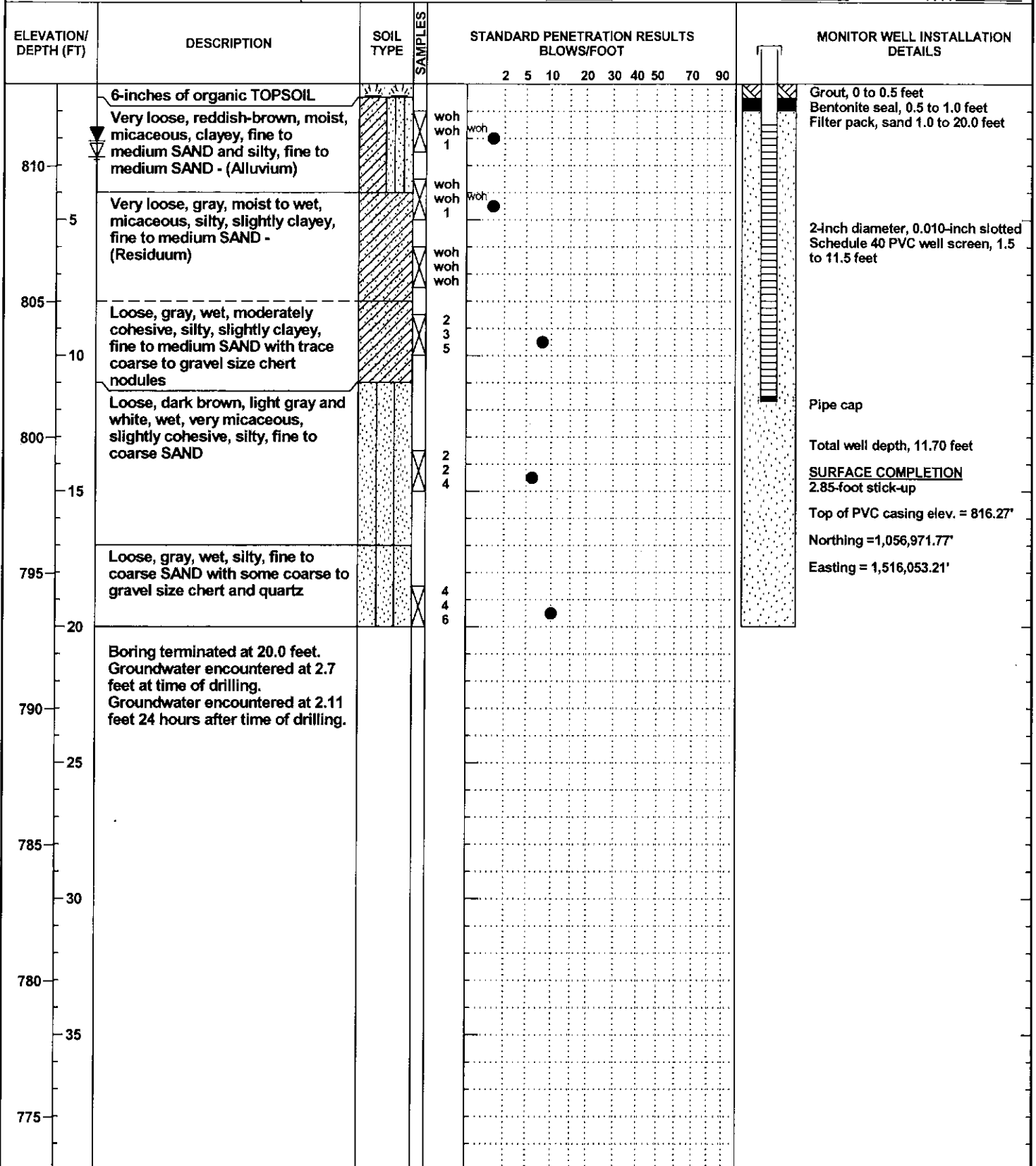



**BUNNELL-LAMMONS  
ENGINEERING, INC.**  
GEOTECHNICAL AND ENVIRONMENTAL  
CONSULTANTS

### GROUNDWATER MONITORING WELL NO. PZ-16

PROJECT: Greenpointe Class 2 Landfill

PROJECT NO.: J17-11684-02

CLIENT: Greenpointe Landfill, LLC

START: 12-5-17 END: 12-5-17

LOCATION: Easley, South Carolina

ELEVATION: 816.24

DRILLER: Landprobe, R. Banks

LOGGED BY: R. Doherty

DRILLING METHOD: CME 750; 4-1/4 inch hollow stem auger

DEPTH TO - WATER> INITIAL: ▽ 8.2 AFTER 24 HOURS: ▽ 1.5 CAVING: ▨

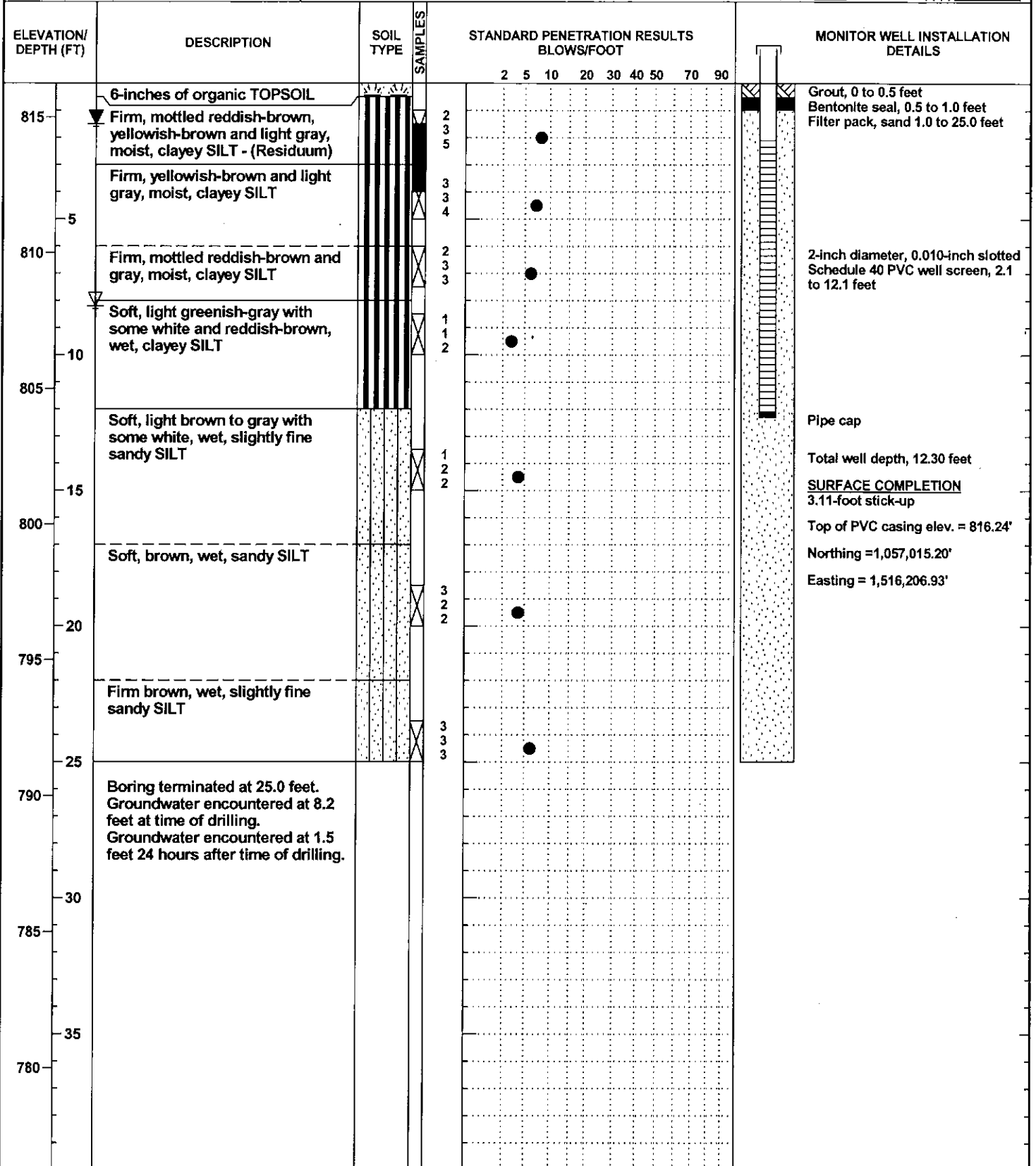





**BUNNELL-LAMMONS  
ENGINEERING, INC.**  
GEOTECHNICAL AND ENVIRONMENTAL  
CONSULTANTS

### GROUNDWATER MONITORING WELL NO. PZ-17

PROJECT: Greenpointe Class 2 Landfill

PROJECT NO.: J17-11684-02

CLIENT: Greenpointe Landfill, LLC

START: 12-5-17 END: 12-5-17

LOCATION: Easley, South Carolina

ELEVATION: 809.76

DRILLER: Landprobe, R. Banks

LOGGED BY: R. Doherty

DRILLING METHOD: CME 750; 4-1/4 inch hollow stem auger

DEPTH TO - WATER> INITIAL:  $\nabla$  10.14 AFTER 24 HOURS:  $\nabla$  8.0 CAVING:  $\otimes$

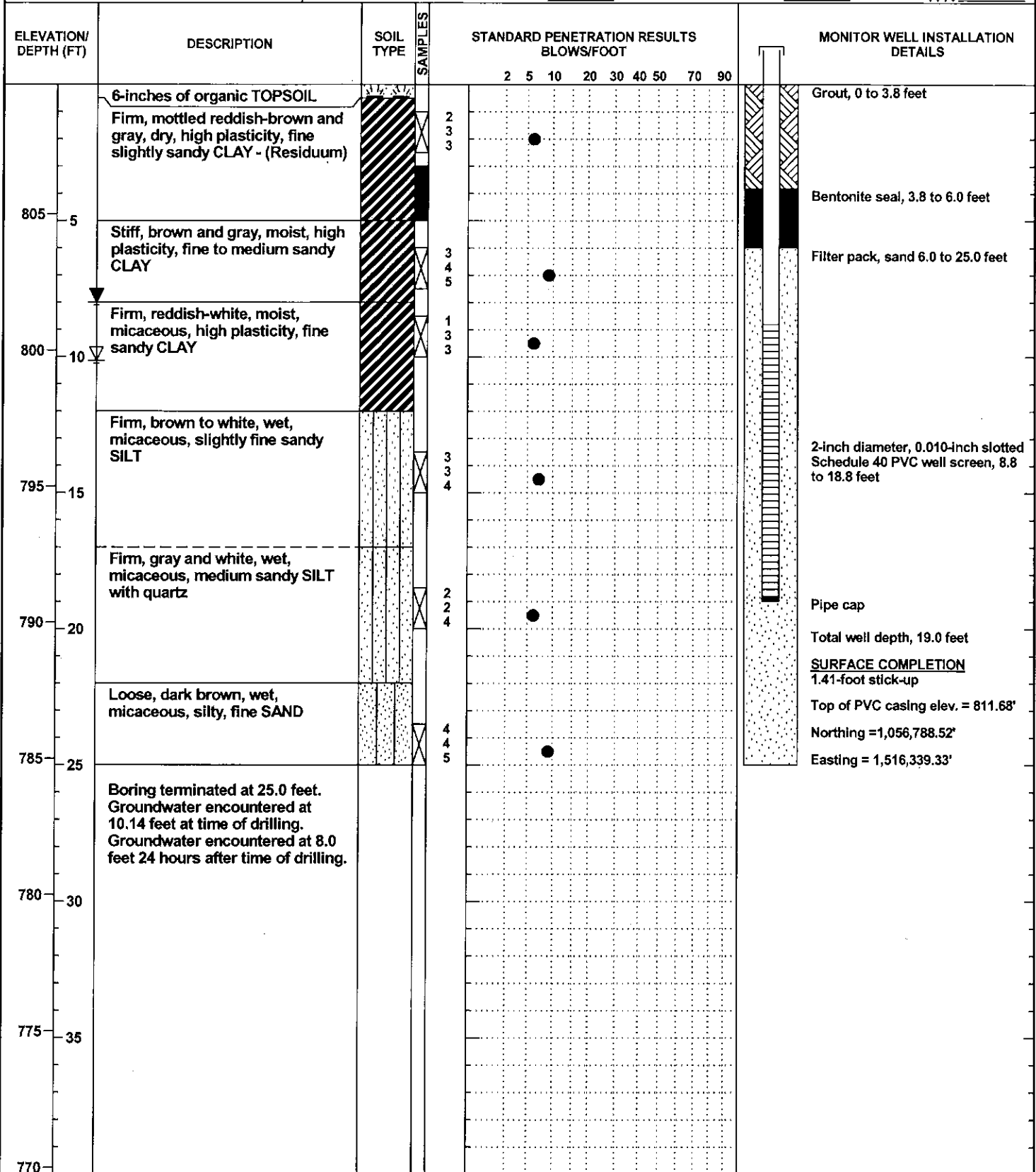



# GROUNDWATER MONITORING WELL NO. PZ-18

**BUNNELL-LAMMONS  
ENGINEERING, INC.**  
GEOTECHNICAL AND ENVIRONMENTAL  
CONSULTANTS

PROJECT: Greenpointe Class 2 Landfill

PROJECT NO.: J17-11684-02

CLIENT: Greenpointe Landfill, LLC

START: 12-5-17 END: 12-5-17

LOCATION: Easley, South Carolina

ELEVATION: 824.02

DRILLER: Landprobe, R. Banks

LOGGED BY: R. Doherty

DRILLING METHOD: CME 750; 4-1/4 inch hollow stem auger

DEPTH TO - WATER> INITIAL:  $\nabla$  10.2 AFTER 24 HOURS:  $\nabla$  5.8 CAVING:

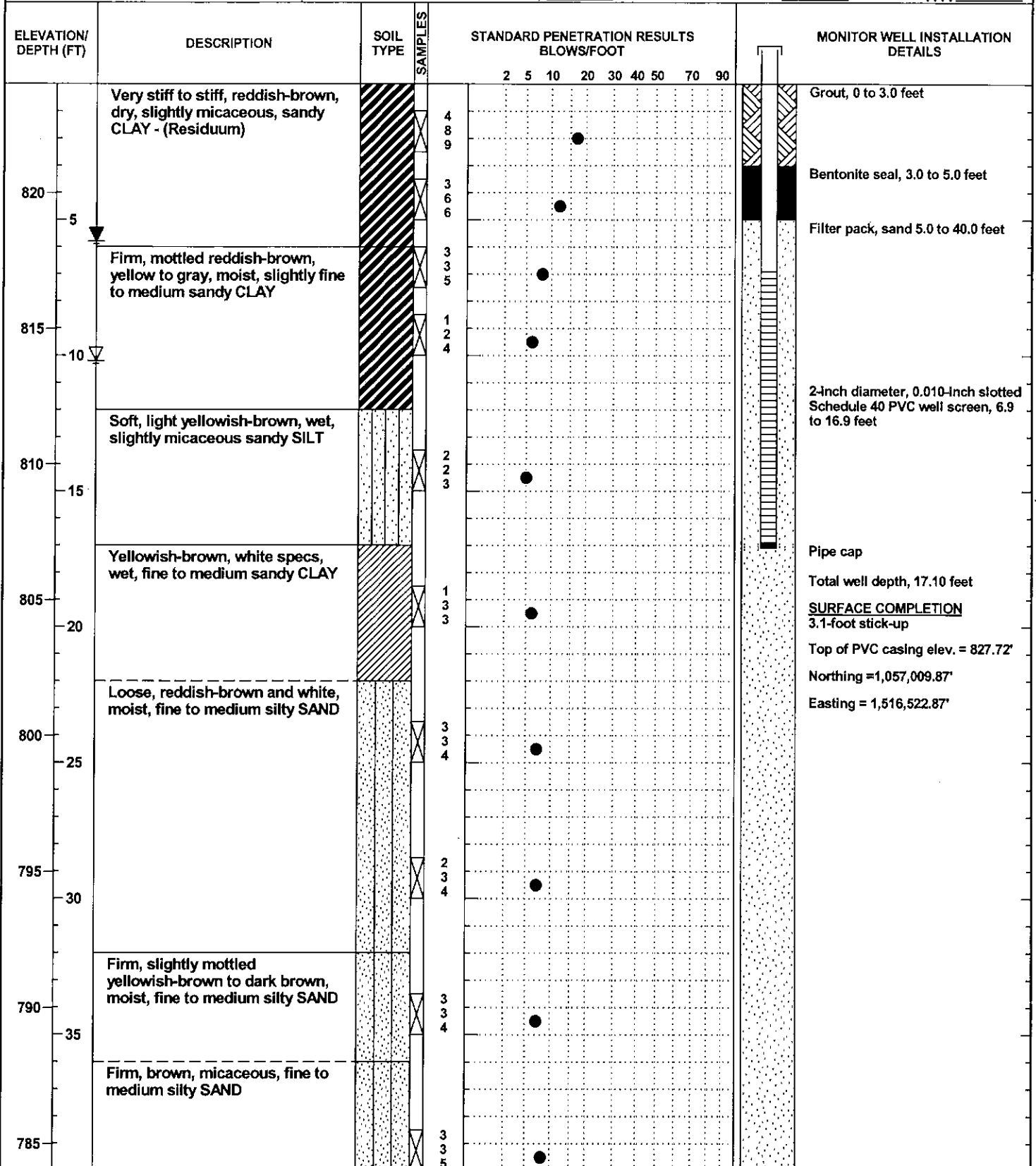

GROUNDWATER MONITORING WELL NO. PZ-18

Sheet 1 of 2

GEOT. WELL 11684-02.GPJ 5/14/19



**BUNNELL-LAMMONS  
ENGINEERING, INC.**  
GEOTECHNICAL AND ENVIRONMENTAL  
CONSULTANTS

### GROUNDWATER MONITORING WELL NO. PZ-18

PROJECT: Greenpointe Class 2 Landfill PROJECT NO.: J17-11684-02  
CLIENT: Greenpointe Landfill, LLC START: 12-5-17 END: 12-5-17  
LOCATION: Easley, South Carolina ELEVATION: 824.02  
DRILLER: Landprobe, R. Banks LOGGED BY: R. Doherty  
DRILLING METHOD: CME 750; 4-1/4 inch hollow stem auger  
DEPTH TO - WATER> INITIAL: ∇ 10.2 AFTER 24 HOURS: ∇ 5.8 CAVING> ☒

ELEVATION/ DEPTH (FT)	DESCRIPTION	SOIL TYPE	SAMPLES	STANDARD PENETRATION RESULTS BLOWS/FOOT								MONITOR WELL INSTALLATION DETAILS										
				2	5	10	20	30	40	50	70		90									
780	Boring terminated at 40.0 feet. Groundwater encountered at 10.2 feet at time of drilling. Groundwater encountered at 5.8 feet 24 hours after time of drilling.																					
775																						
770																						
765																						
760																						
755																						
750																						
745																						

GEOT. WELL\_11684-02.GPJ 5/14/19



**BUNNELL-LAMMONS  
ENGINEERING, INC.**  
GEOTECHNICAL AND ENVIRONMENTAL  
CONSULTANTS

**GROUNDWATER MONITORING WELL NO. PZ-19**

PROJECT: Greenpointe Class 2 Landfill

PROJECT NO.: J17-11684-02

CLIENT: Greenpointe Landfill, LLC

START: 12-6-17 END: 12-6-17

LOCATION: Easley, South Carolina

ELEVATION: 837.05

DRILLER: Landprobe, R. Banks

LOGGED BY: R. Doherty

DRILLING METHOD: CME 750; 4-1/4 inch hollow stem auger

DEPTH TO - WATER> INITIAL:  $\nabla$  15.25 AFTER 24 HOURS:  $\nabla$  28.16 CAVING:  $\otimes$

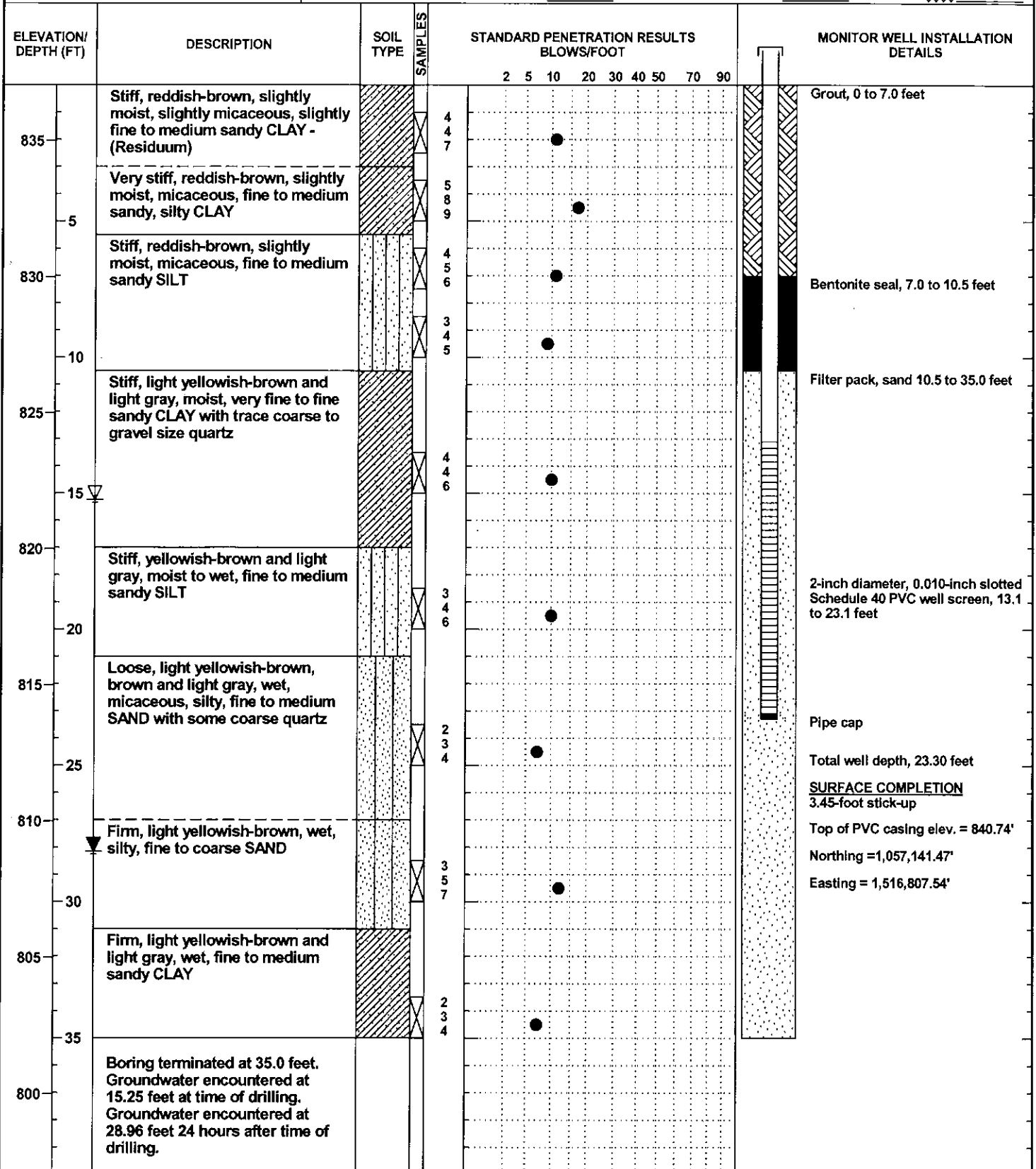

GEO. WELL 11684-02.GPJ 5/14/19



**BUNNELL-LAMMONS  
ENGINEERING, INC.**  
GEOTECHNICAL AND ENVIRONMENTAL  
CONSULTANTS

**GROUNDWATER MONITORING WELL NO. PZ-20**

PROJECT: Greenpointe Class 2 Landfill

PROJECT NO.: J17-11684-02

CLIENT: Greenpointe Landfill, LLC

START: 12-6-17 END: 12-18-17

LOCATION: Easley, South Carolina

ELEVATION: 847.19

DRILLER: Landprobe, R. Banks

LOGGED BY: R. Doherty

DRILLING METHOD: CME 750; 4-1/4 inch hollow stem auger

DEPTH TO - WATER> INITIAL:  $\nabla$  17.70 AFTER 24 HOURS:  $\nabla$  20.11 CAVING:

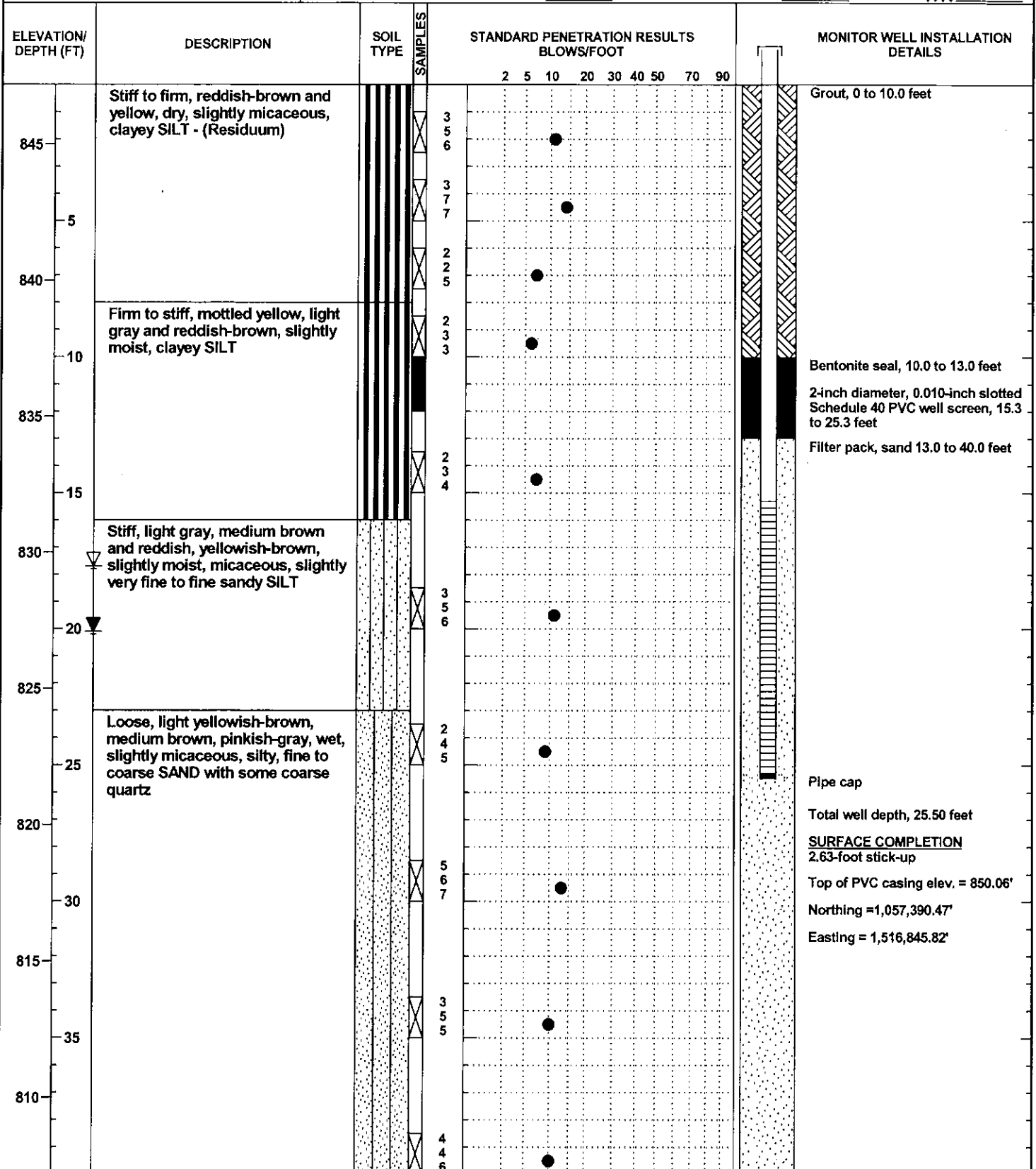

GEOI\_WELL\_11684-02.GPJ 5/14/19





**BUNNELL-LAMMONS  
ENGINEERING, INC.**  
GEOTECHNICAL AND ENVIRONMENTAL  
CONSULTANTS

## GROUNDWATER MONITORING WELL NO. PZ-21

PROJECT: Greenpointe Class 2 Landfill

PROJECT NO.: J17-11684-02

CLIENT: Greenpointe Landfill, LLC

START: 12-18-17 END: 12-18-17

LOCATION: Easley, South Carolina

ELEVATION: 833.02

DRILLER: Landprobe, R. Banks

LOGGED BY: R. Doherty

DRILLING METHOD: CME 750; 4-1/4 inch hollow stem auger

DEPTH TO - WATER> INITIAL:  $\nabla$  5.7 AFTER 24 HOURS:  $\nabla$  7.42 CAVING:

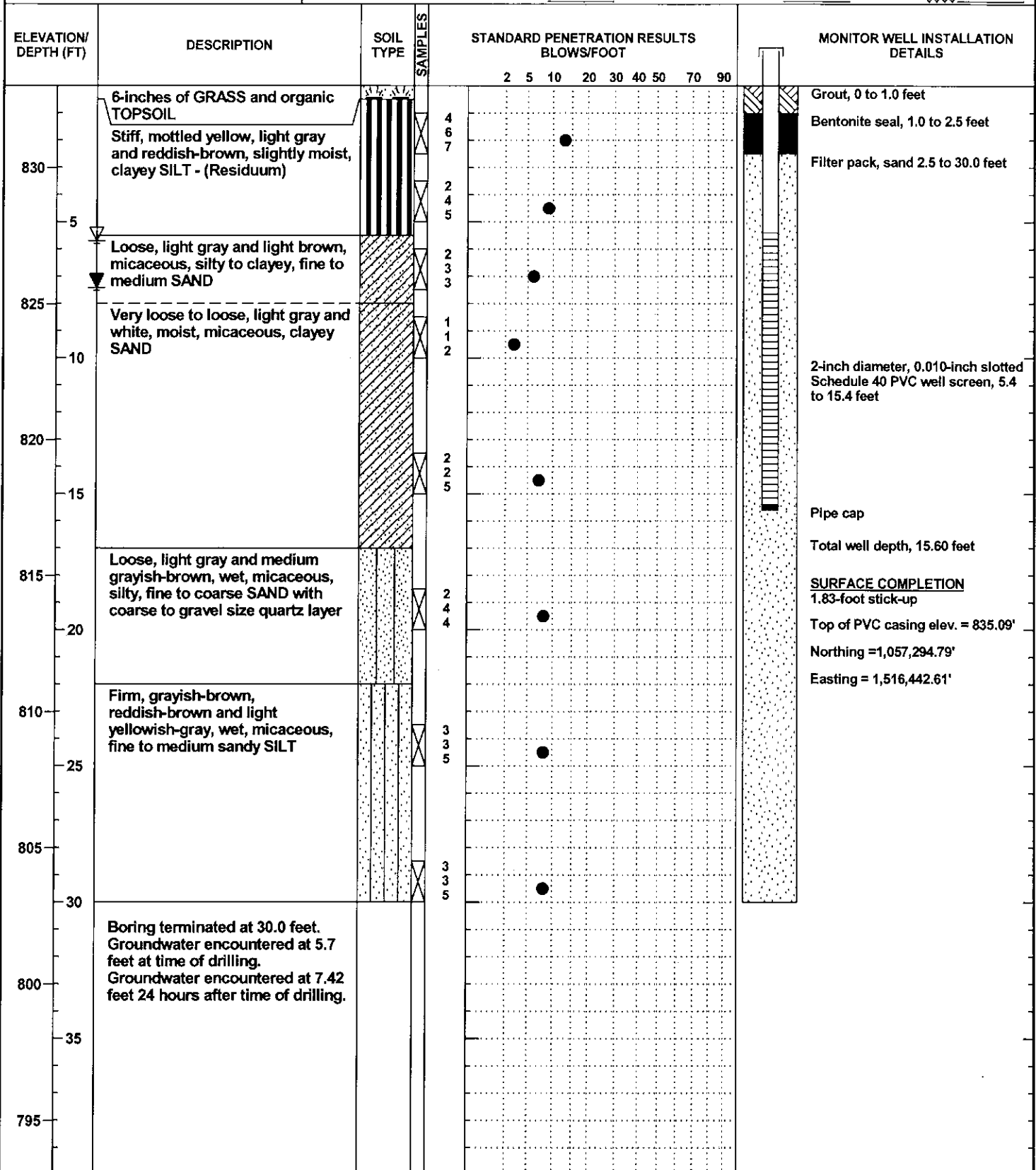

GEO. WELL 11684-02.GPJ 5/14/19



**BUNNELL-LAMMONS  
ENGINEERING, INC.**  
GEOTECHNICAL AND ENVIRONMENTAL  
CONSULTANTS

## GROUNDWATER MONITORING WELL NO. PZ-22

PROJECT: <u>Greenpointe Class 2 Landfill</u>	PROJECT NO.: <u>J17-11684-02</u>
CLIENT: <u>Greenpointe Landfill, LLC</u>	START: <u>12-18-17</u> END: <u>12-18-17</u>
LOCATION: <u>Easley, South Carolina</u>	ELEVATION: <u>846.99</u>
DRILLER: <u>Landprobe, R. Banks</u>	LOGGED BY: <u>R. Doherty</u>
DRILLING METHOD: <u>CME 750; 4-1/4 inch hollow stem auger</u>	
DEPTH TO - WATER> INITIAL: $\nabla$ <u>13.88</u> AFTER 24 HOURS: $\nabla$ <u>16.69</u> CAVING: $\otimes$	

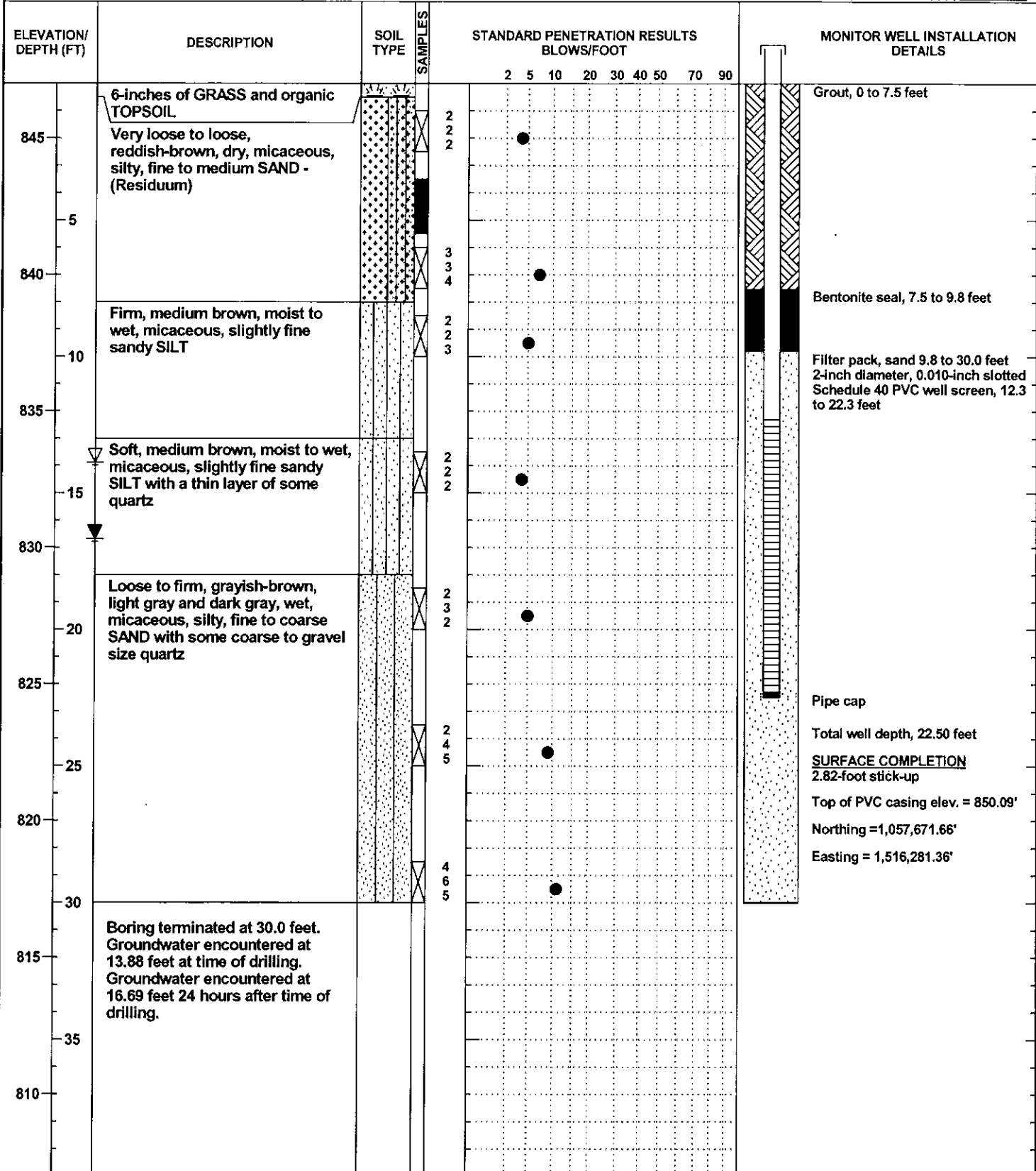

GEOT\_WELL\_11684-02.GPJ\_5/14/19





**BUNNELL-LAMMONS  
ENGINEERING, INC.**  
GEOTECHNICAL AND ENVIRONMENTAL  
CONSULTANTS

**GROUNDWATER MONITORING WELL NO. PZ-23**

PROJECT: Greenpointe Class 2 Landfill

PROJECT NO.: J17-11684-02

CLIENT: Greenpointe Landfill, LLC

START: 12-19-17 END: 12-19-17

LOCATION: Easley, South Carolina

ELEVATION: 834.58

DRILLER: Landprobe, R. Banks

LOGGED BY: R. Doherty

DRILLING METHOD: CME 750; 4-1/4 inch hollow stem auger

DEPTH TO - WATER> INITIAL: ▽ 4.82 AFTER 24 HOURS: ▽ 9.0 CAVING: ▣

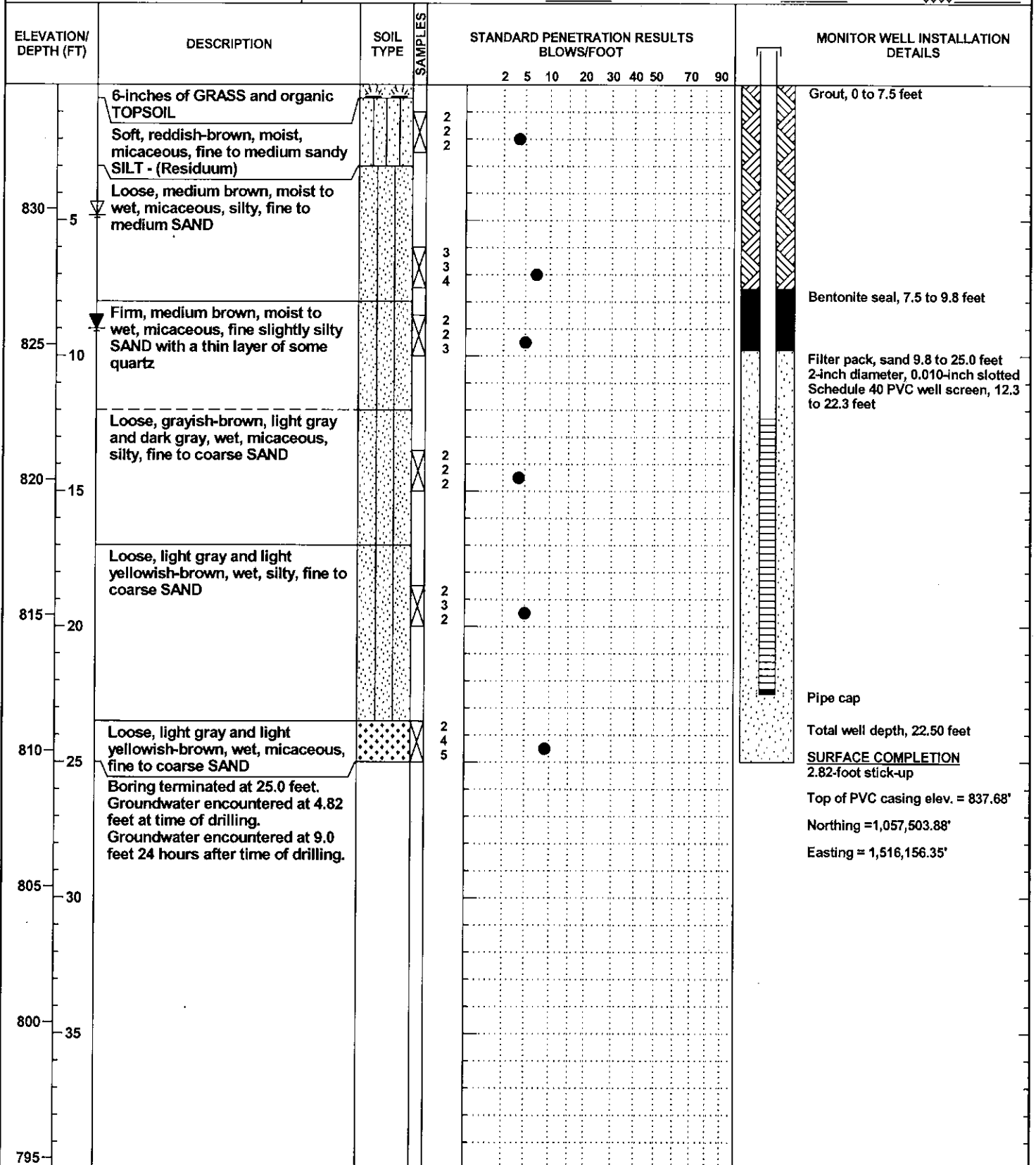

GEOI\_WELL\_11684-02.GPJ 5/14/19



**BUNNELL-LAMMONS  
ENGINEERING, INC.**  
GEOTECHNICAL AND ENVIRONMENTAL  
CONSULTANTS

**GROUNDWATER MONITORING WELL NO. PZ-24**

PROJECT: Greenpointe Class 2 Landfill

PROJECT NO.: J17-11684-02

CLIENT: Greenpointe Landfill, LLC

START: 3-22-18 END: 3-23-18

LOCATION: Easley, South Carolina

ELEVATION: 821.40

DRILLER: Landprobe, S. Dyer

LOGGED BY: B.P. Davis

DRILLING METHOD: CME 750; 4-1/4 inch hollow stem auger

DEPTH TO - WATER> INITIAL: ▽ 13.11 AFTER 24 HOURS: ▽ 13.13 CAVING> ☒

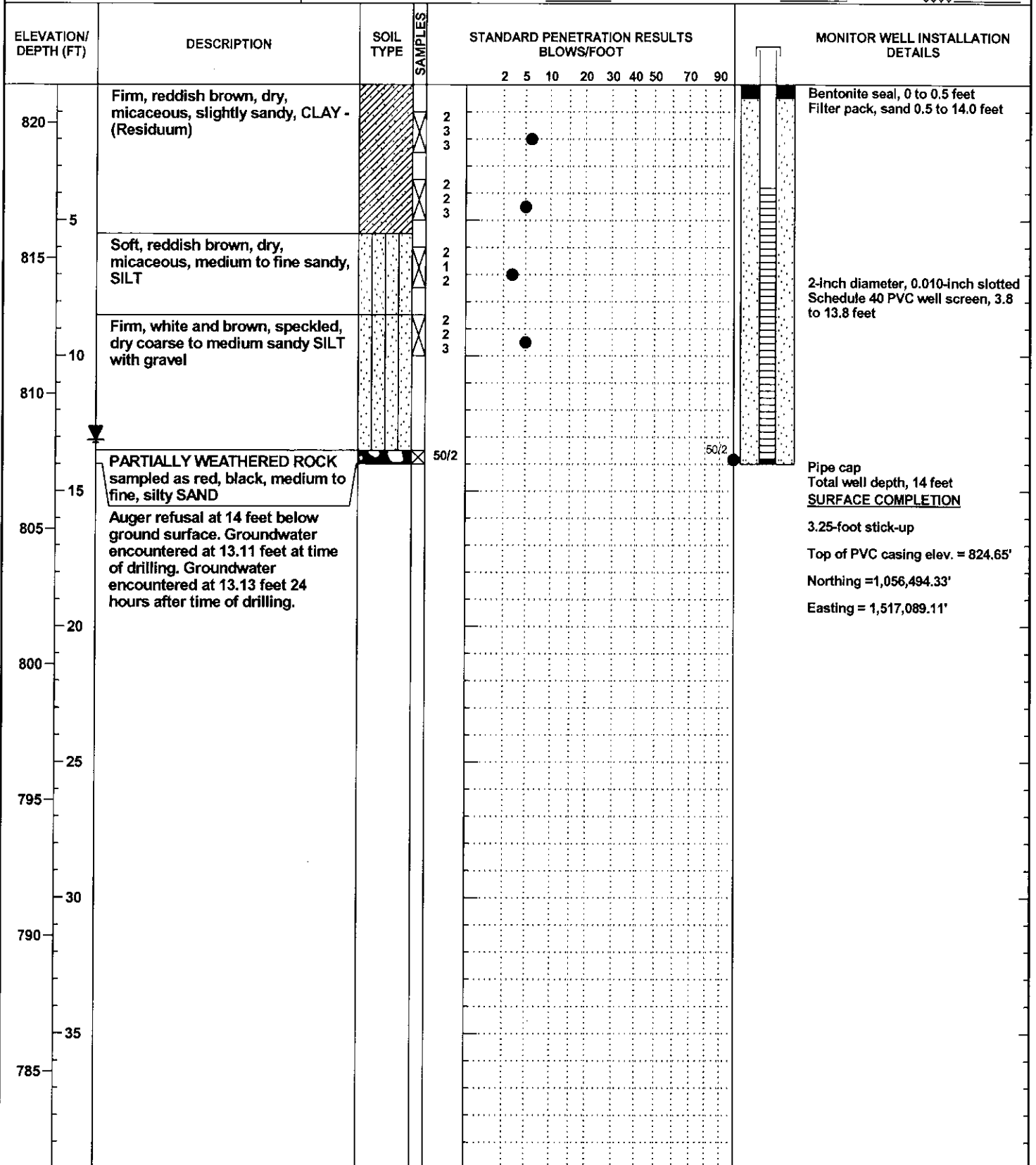

GEOI\_WELL\_11684-02.GPJ 5/14/19



**BUNNELL-LAMMONS  
ENGINEERING, INC.**  
GEOTECHNICAL AND ENVIRONMENTAL  
CONSULTANTS

### GROUNDWATER MONITORING WELL NO. PZ-25

PROJECT: Greenpointe Class 2 Landfill

PROJECT NO.: J17-11684-02

CLIENT: Greenpointe Landfill, LLC

START: 3-23-18 END: 3-23-18

LOCATION: Easley, South Carolina

ELEVATION: 819.71

DRILLER: Landprobe, S. Dyer

LOGGED BY: M. Parks

DRILLING METHOD: CME 750; 4-1/4 inch hollow stem auger

DEPTH TO - WATER> INITIAL:  $\nabla$  16.2 AFTER 24 HOURS:  $\nabla$  18.87 CAVING:

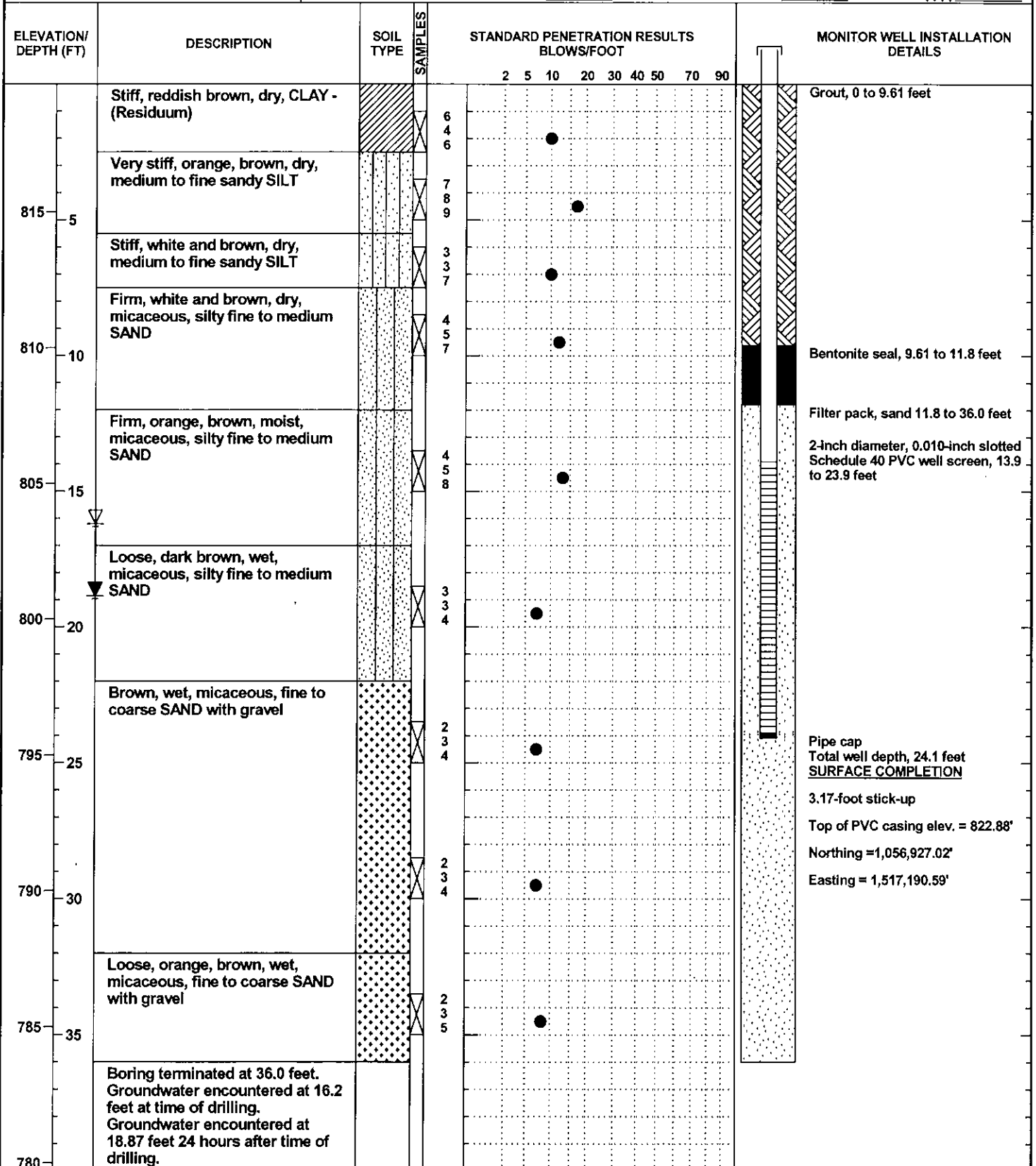

GEOT\_WELL\_11684-02.GPJ 5/14/19

**HYDRAULIC CONDUCTIVITY TEST REPORT**  
 CONSTANT VOLUME APPARATUS (ASTM D 5084)

PROJECT: GREENPOINT LANDFILL  
 PROJECT NO.: J17-11684-02  
 DATE RECEIVED: 12-20-17

TESTED BY: JOHN MATHEW  
 CHECKED BY: PAUL YARBER

SAMPLE NO. <u>PZ-16</u>	SAMPLE LOCATION: <u>2.0-4.0'</u>
TYPE <u>UNDISTURBED</u>	SAMPLE DESCRIPTION: <u>YELLOWISH BROWN FL.-MED. SANDY ELASTIC SILT</u>

**SAMPLE DIMENSIONS AND PROPERTIES**

ITEM	INITIAL		FINAL	
	inches	centimeters	inches	centimeters
Sample Length	2.923	7.424	2.893	7.348
Sample Diameter	2.861	7.267	2.838	7.209
Length/Diameter Ratio		1.02		
Moisture Content (%)	WW= 180.4 DW= 131.1	37.6	WW= 241.8 DW= 177.0	36.6
Sample Wet Weight (grams)	548.4		547.7	
Wet Density (pcf)	111.2		114.0	
Dry Density (pcf)	80.8		83.5	
Saturation (%)	93		97	

**HYDRAULIC CONDUCTIVITY TESTING MEASUREMENT**  
 (PERMOMETER)

Chamber Pressure (psi)	70	Influent Pressure (psi)	60	Effluent Pressure (psi)	60	B-Value	0.96			
Reset (Y/N)	Date	Clock Time	Elapsed Time	HA <sub>OUT</sub> (cm)	HA <sub>IN</sub> (cm)	Temp °C	Gradient	K (cm/sec)	Temp Correction	K <sub>20°C</sub> (cm/sec)
Y	12-21-17	2:45:40		4.7	1.99	22.0	5			
	12-21-17	2:47:51	0:02:11	4.0	2.02	22.0	4	1.0E-06	0.953	9.9E-07
	12-21-17	2:48:14	0:02:34	3.9	2.03	22.0	4	1.0E-06	0.953	9.8E-07
	12-21-17	2:48:40	0:03:00	3.8	2.03	22.0	3	1.0E-06	0.953	9.7E-07
	12-21-17	2:49:05	0:03:25	3.7	2.03	22.0	3	1.0E-06	0.953	9.7E-07

**HYDRAULIC CONDUCTIVITY (K<sub>20°C</sub>)      9.8E-07      cm/sec**

**HYDRAULIC CONDUCTIVITY TEST REPORT**  
 CONSTANT VOLUME APPARATUS (ASTM D 5084)

PROJECT: GREENPOINT LANDFILL  
 PROJECT NO.: J17-11684-02  
 DATE RECEIVED: 12-20-17

TESTED BY: JOHN MATHEW  
 CHECKED BY: PAUL YARBER

SAMPLE NO. <u>PZ-17</u>	SAMPLE LOCATION: <u>3.0-5.0'</u>
TYPE <u>UNDISTURBED</u>	SAMPLE DESCRIPTION: <u>GREY YELLOW &amp; BROWN FL-MED. SANDY CLAY</u>

**SAMPLE DIMENSIONS AND PROPERTIES**

ITEM	INITIAL		FINAL	
	inches	centimeters	inches	centimeters
Sample Length	2.967	7.536	2.952	7.498
Sample Diameter	2.856	7.254	2.854	7.249
Length/Diameter Ratio		1.04		
Moisture Content (%)	WW= 157.1 DW= 124.9	25.8	WW= 225.5 DW= 176.5	27.8
Sample Wet Weight (grams)	615.0		621.3	
Wet Density (pcf)	123.3		125.3	
Dry Density (pcf)	98.0		98.1	
Saturation (%)	TESTED SG= 2.71	96	104	

**HYDRAULIC CONDUCTIVITY TESTING MEASUREMENT**  
 (PERMOMETER)

Chamber Pressure (psi)	70	Influent Pressure (psi)	60	Effluent Pressure (psi)	60	B-Value	0.96			
Reset (Y/N)	Date	Clock Time	Elapsed Time	HA <sub>OUT</sub> (cm)	HA <sub>IN</sub> (cm)	Temp °C	Gradient	K (cm/sec)	Temp Correction	K <sub>20°C</sub> (cm/sec)
Y	12-22-17	8:26:33		7.7	1.87	21.0	10			
	12-22-17	8:31:52	0:05:19	6.8	1.91	21.0	9	2.4E-07	0.976	2.3E-07
	12-22-17	8:32:31	0:05:58	6.7	1.91	21.0	8	2.4E-07	0.976	2.3E-07
	12-22-17	8:33:12	0:06:39	6.6	1.92	21.0	8	2.4E-07	0.976	2.3E-07
	12-22-17	8:34:00	0:07:27	6.5	1.92	21.0	8	2.4E-07	0.976	2.3E-07

**HYDRAULIC CONDUCTIVITY (K<sub>20°C</sub>)      2.3E-07      cm/sec**

**HYDRAULIC CONDUCTIVITY TEST REPORT**  
 CONSTANT VOLUME APPARATUS (ASTM D 5084)

PROJECT: GREENPOINT LANDFILL  
 PROJECT NO.: J17-11684-02  
 DATE RECEIVED: 12-20-17

TESTED BY: JOHN MATHEW  
 CHECKED BY: PAUL YARBER

SAMPLE NO. <u>PZ-20</u>	SAMPLE LOCATION: <u>10.0-12.0'</u>
TYPE <u>UNDISTURBED</u>	SAMPLE DESCRIPTION: <u>YELLOW &amp; BROWN FL.-MED. SANDY ELASTIC SILT</u>

**SAMPLE DIMENSIONS AND PROPERTIES**

ITEM	INITIAL		FINAL	
	inches	centimeters	inches	centimeters
Sample Length	2.896	7.356	2.865	7.277
Sample Diameter	2.851	7.242	2.844	7.224
Length/Diameter Ratio		1.02		
Moisture Content (%)	WW= 174.8 DW= 123.8	41.2	WW= 174.4 DW= 122.7	42.1
Sample Wet Weight (grams)	534.8		534.8	
Wet Density (pcf)	110.2		111.9	
Dry Density (pcf)	78.0		78.8	
Saturation (%)	TESTED SG= 2.71	96	100	

**HYDRAULIC CONDUCTIVITY TESTING MEASUREMENT**  
 (PERMOMETER)

Chamber Pressure (psi)	70	Influent Pressure (psi)	60	Effluent Pressure (psi)	60	B-Value	0.96			
Reset (Y/N)	Date	Clock Time	Elapsed Time	HA <sub>OUT</sub> (cm)	HA <sub>IN</sub> (cm)	Temp °C	Gradient	K (cm/sec)	Temp Correction	K <sub>20°C</sub> (cm/sec)
Y	12-22-17	8:51:52		7.5	1.88	21.0	10			
	12-22-17	8:53:21	0:01:29	5.5	1.96	21.0	6	2.2E-06	0.976	2.2E-06
	12-22-17	8:53:33	0:01:41	5.3	1.97	21.0	6	2.2E-06	0.976	2.2E-06
	12-22-17	8:53:52	0:02:00	5.0	1.98	21.0	6	2.2E-06	0.976	2.2E-06
	12-22-17	8:54:06	0:02:14	4.8	1.99	21.0	5	2.2E-06	0.976	2.2E-06

**HYDRAULIC CONDUCTIVITY (K<sub>20°C</sub>)      2.2E-06      cm/sec**

**HYDRAULIC CONDUCTIVITY TEST REPORT**  
 CONSTANT VOLUME APPARATUS (ASTM D 5084)

PROJECT: GREENPOINT LANDFILL  
 PROJECT NO.: J17-11684-02  
 DATE RECEIVED: 12-20-17

TESTED BY: JOHN MATHEW  
 CHECKED BY: PAUL YARBER

SAMPLE NO.	<u>PZ-22</u>	SAMPLE LOCATION:	<u>3.0-5.0'</u>
TYPE	<u>UNDISTURBED</u>	SAMPLE DESCRIPTION:	<u>BROWN SILTY FL-MED. SAND</u>

**SAMPLE DIMENSIONS AND PROPERTIES**

ITEM	INITIAL		FINAL	
	inches	centimeters	inches	centimeters
Sample Length	2.873	7.297	2.863	7.272
Sample Diameter	2.845	7.226	2.824	7.173
Length/Diameter Ratio		1.01		
Moisture Content (%)	WW= 200.2    DW= 180.2	11.1	WW= 198.0    DW= 158.0	25.3
Sample Wet Weight (grams)	513.8		574.5	
Wet Density (pcf)	107.2		122.0	
Dry Density (pcf)	96.5		97.4	
Saturation (%)	41		96	

**HYDRAULIC CONDUCTIVITY TESTING MEASUREMENT**  
 FALLING HEAD TEST

Confining Pressure (psi)		Influent Pressure (psi)		Effluent Pressure (psi)		B-Value								
90.2		80.2		80.0		0.95								
Date	Clock Time		Elapsed Time seconds	Pipet Readings				Head		Temp °C	Gradient	K (cm/sec)	Temp Correction	K <sub>20°C</sub> (cm/sec)
	Start	End		Initial		Final		Initial cm	Final cm					
12-28-17	10:47:00	10:47:12	12	1.0	23.0	3.0	21.0	40.092	35.360	21.0	5	8.0E-04	0.976	7.8E-04
12-28-17	10:47:12	10:47:25	13	3.0	21.0	5.0	19.0	35.360	30.629	21.0	5	8.4E-04	0.976	8.2E-04
12-28-17	10:47:25	10:47:40	15	5.0	19.0	7.0	17.0	30.629	25.897	21.0	5	8.5E-04	0.976	8.3E-04
12-28-17	10:47:40	10:47:58	18	7.0	17.0	9.0	15.0	25.897	21.165	21.0	5	8.5E-04	0.976	8.3E-04
				Pipet Length, cm		28.390	28.390							
				Pipet Volume, cc		24	24							
				Cross-sectional Area of Pipet, cm <sup>2</sup>		0.8454	0.8454							

**HYDRAULIC CONDUCTIVITY (K<sub>20°C</sub>)                      8.1E-04    cm/sec**

# LIQUID AND PLASTIC LIMITS TEST REPORT

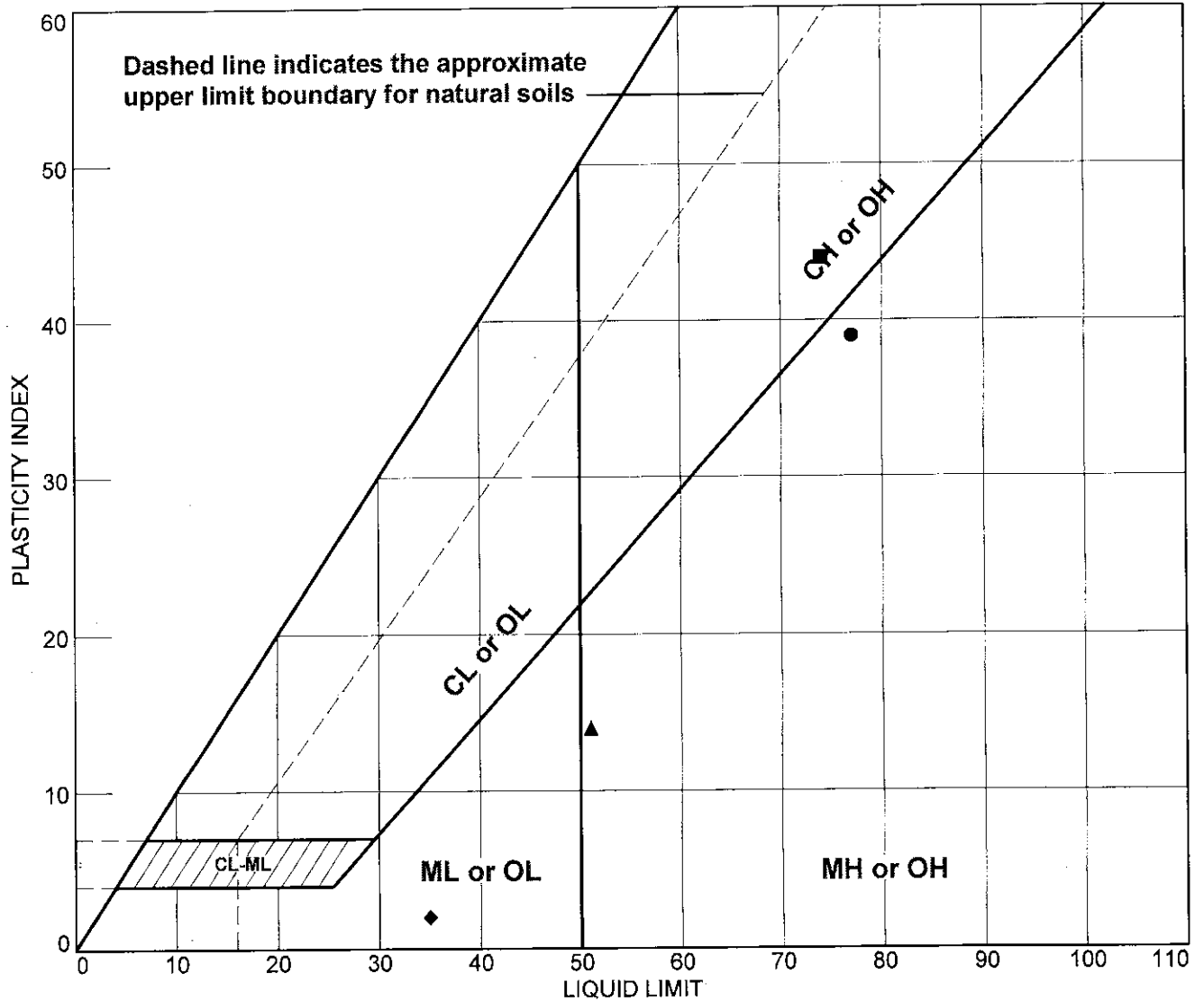

SOIL DATA								
SYMBOL	SOURCE	SAMPLE NO.	DEPTH	NATURAL WATER CONTENT (%)	PLASTIC LIMIT (%)	LIQUID LIMIT (%)	PLASTICITY INDEX (%)	USCS
●	Boring	PZ-16 A	2.0-4.0	37.4	38	77	39	MH
■	Boring	PZ-17 A	3.0-5.0	25.8	30	74	44	CH
▲	Boring	PZ-20 A	10.0-12.0	41.2	37	51	14	MH
◆	Boring	PZ-22 A	3.0-5.0	11.1	33	35	2	SM

**Bunnell Lammons Engineering, Inc.**

**Client:** Greenpoint Landfill, LLC

**Project:** Greenpoint Landfill

**Greenville, SC**

**Project No.:** 11684-02

**Figure**



**HYDRAULIC CONDUCTIVITY TEST REPORT**  
 CONSTANT VOLUME APPARATUS (ASTM D 5084)

PROJECT: GREENPOINT LANDFILL  
 PROJECT NO.: J17-11684-02  
 DATE RECEIVED: 1-3-19

TESTED BY: JOHN MATHEW  
 CHECKED BY: PAUL YARBER

SAMPLE NO. <u>PZ-16</u>	SAMPLE LOCATION: <u>1.5-4.0</u>
TYPE <u>UNDISTURBED</u>	SAMPLE DESCRIPTION: <u>GREY &amp; BROWN FL.-MED. SANDY CLAY</u>

**SAMPLE DIMENSIONS AND PROPERTIES**

ITEM	INITIAL		FINAL	
	inches	centimeters	inches	centimeters
Sample Length	2.984	7.579	2.988	7.590
Sample Diameter	2.841	7.216	2.834	7.198
Length/Diameter Ratio		1.05		
Moisture Content (%)	WW= 162.3 DW= 127.7	27.1	WW= 201.5 DW= 151.6	32.9
Sample Wet Weight (grams)	569.7		582.9	
Wet Density (pcf)	114.7		117.8	
Dry Density (pcf)	90.3		88.6	
Saturation (%)	86		101	

**HYDRAULIC CONDUCTIVITY TESTING MEASUREMENT**  
 (PERMOMETER)

Chamber Pressure (psi)	70	Influent Pressure (psi)	60	Effluent Pressure (psi)	60	B-Value	0.96			
Reset (Y/N)	Date	Clock Time	Elapsed Time	HA <sub>OUT</sub> (cm)	HA <sub>IN</sub> (cm)	Temp °C	Gradient	K (cm/sec)	Temp Correction	K <sub>20°C</sub> (cm/sec)
Y	1-7-19	2:42:07		5.0	2.19	23.0	5			
	1-7-19	2:42:28	0:00:21	4.0	2.23	23.0	3	9.9E-06	0.931	9.2E-06
	1-7-19	2:42:44	0:00:37	3.5	2.25	23.0	2	9.8E-06	0.931	9.1E-06
	1-7-19	2:43:09	0:01:02	3.0	2.27	23.0	2	9.8E-06	0.931	9.1E-06
	1-7-19	2:43:35	0:01:28	2.7	2.28	23.0	1	9.7E-06	0.931	9.1E-06

**HYDRAULIC CONDUCTIVITY (K<sub>20°C</sub>)      9.1E-06      cm/sec**

**HYDRAULIC CONDUCTIVITY TEST REPORT**  
 CONSTANT VOLUME APPARATUS (ASTM D 5084)

PROJECT: GREENPOINT LANDFILL  
 PROJECT NO.: J17-11684-02  
 DATE RECEIVED: 1-3-19

TESTED BY: JOHN MATHEW  
 CHECKED BY: PAUL YARBER

SAMPLE NO. <u>PZ-17</u>	SAMPLE LOCATION: <u>3.0-5.0</u>
TYPE <u>UNDISTURBED</u>	SAMPLE DESCRIPTION: <u>GREY &amp; BROWN FL.-MED. SANDY CLAY</u>

**SAMPLE DIMENSIONS AND PROPERTIES**

ITEM	INITIAL		FINAL	
	inches	centimeters	inches	centimeters
Sample Length	2.975	7.557	2.975	7.557
Sample Diameter	2.871	7.292	2.857	7.257
Length/Diameter Ratio		1.04		
Moisture Content (%)	WW= 167.0 DW= 131.4	27.1	WW= 217.5 DW= 169.7	28.2
Sample Wet Weight (grams)	609.1		619.0	
Wet Density (pcf)	120.5		123.6	
Dry Density (pcf)	94.8		96.5	
Saturation (%)	94		102	

**HYDRAULIC CONDUCTIVITY TESTING MEASUREMENT**  
 (PERMOMETER)

Chamber Pressure (psi)	70	Influent Pressure (psi)	60	Effluent Pressure (psi)	60	B-Value	0.96			
Reset (Y/N)	Date	Clock Time	Elapsed Time	HA <sub>OUT</sub> (cm)	HA <sub>IN</sub> (cm)	Temp °C	Gradient	K (cm/sec)	Temp Correction	K <sub>20°C</sub> (cm/sec)
Y	1-7-19	2:55:03		7.9	2.07	23.0	10			
	1-7-19	3:02:23	0:07:20	7.0	2.11	23.0	8	1.7E-07	0.931	1.6E-07
	1-7-19	3:03:23	0:08:20	6.9	2.11	23.0	8	1.7E-07	0.931	1.6E-07
	1-7-19	3:04:25	0:09:22	6.8	2.12	23.0	8	1.7E-07	0.931	1.6E-07
	1-7-19	3:05:24	0:10:21	6.7	2.12	23.0	8	1.7E-07	0.931	1.6E-07

**HYDRAULIC CONDUCTIVITY (K<sub>20°C</sub>)      1.6E-07      cm/sec**

**HYDRAULIC CONDUCTIVITY TEST REPORT**  
 CONSTANT VOLUME APPARATUS (ASTM D 5084)

PROJECT: GREENPOINT LANDFILL  
 PROJECT NO.: J17-11684-02  
 DATE RECEIVED: 1-3-19

TESTED BY: JOHN MATHEW  
 CHECKED BY: PAUL YARBER

SAMPLE NO. <u>PZ-20</u>	SAMPLE LOCATION: <u>10.0-12.0</u>
TYPE <u>UNDISTURBED</u>	SAMPLE DESCRIPTION: <u>YELLOWISH BROWN FL.-MED. SANDY ELSTIC SILT</u>

**SAMPLE DIMENSIONS AND PROPERTIES**

ITEM	INITIAL		FINAL	
	inches	centimeters	inches	centimeters
Sample Length	2.995	7.607	2.991	7.597
Sample Diameter	2.856	7.254	2.858	7.259
Length/Diameter Ratio		1.05		
Moisture Content (%)	WW= 168.6 DW= 120.6	39.8	WW= 227.9 DW= 161.4	41.2
Sample Wet Weight (grams)	541.2		556.7	
Wet Density (pcf)	107.5		110.5	
Dry Density (pcf)	76.9		78.3	
Saturation (%)	91		98	

**HYDRAULIC CONDUCTIVITY TESTING MEASUREMENT**  
 (PERMOMETER)

Chamber Pressure (psi)	70	Influent Pressure (psi)	60	Effluent Pressure (psi)	60	B-Value	0.96			
Reset (Y/N)	Date	Clock Time	Elapsed Time	HA <sub>OUT</sub> (cm)	HA <sub>IN</sub> (cm)	Temp °C	Gradient	K (cm/sec)	Temp Correction	K <sub>20°C</sub> (cm/sec)
Y	1-7-19	3:12:41		7.9	2.07	23.0	10			
	1-7-19	3:13:12	0:00:31	7.0	2.11	23.0	8	2.5E-06	0.931	2.3E-06
	1-7-19	3:13:33	0:00:52	6.5	2.13	23.0	8	2.4E-06	0.931	2.3E-06
	1-7-19	3:13:46	0:01:05	6.2	2.14	23.0	7	2.5E-06	0.931	2.3E-06
	1-7-19	3:14:24	0:01:43	5.5	2.17	23.0	6	2.4E-06	0.931	2.2E-06

**HYDRAULIC CONDUCTIVITY (K<sub>20°C</sub>)      2.3E-06      cm/sec**

**HYDRAULIC CONDUCTIVITY TEST REPORT**  
 CONSTANT VOLUME APPARATUS (ASTM D 5084)

PROJECT: GREENPOINT LANDFILL  
 PROJECT NO.: J17-11684-02  
 DATE RECEIVED: 1-3-19

TESTED BY: JOHN MATHEW  
 CHECKED BY: PAUL YARBER

SAMPLE NO. <u>PZ-22</u>	SAMPLE LOCATION: <u>3.5-5.5</u>
TYPE <u>UNDISTURBED</u>	SAMPLE DESCRIPTION: <u>BROWN SILTY FL.-MED. SAND</u>

**SAMPLE DIMENSIONS AND PROPERTIES**

ITEM	INITIAL		FINAL	
	inches	centimeters	inches	centimeters
Sample Length	2.923	7.424	2.837	7.206
Sample Diameter	2.839	7.211	2.835	7.201
Length/Diameter Ratio		1.03		
Moisture Content (%)	WW= 156.9    DW= 140.5	11.7	WW= 222.6    DW= 165.8	34.3
Sample Wet Weight (grams)	461.6		543.6	
Wet Density (pcf)	95.0		115.6	
Dry Density (pcf)	85.1		86.1	
Saturation (%)	32		96	

**HYDRAULIC CONDUCTIVITY TESTING MEASUREMENT**  
 FALLING HEAD TEST

Confining Pressure (psi) <u>70.2</u>		Influent Pressure (psi) <u>60.2</u>		Effluent Pressure (psi) <u>60.0</u>		B-Value <u>0.96</u>								
Date	Clock Time		Elapsed Time seconds	Pipet Readings				Head		Temp °C	Gradient	K (cm/sec)	Temp Correction	K <sub>20°C</sub> (cm/sec)
	Start	End		Initial		Final		Initial cm	Final cm					
1-14-19	11:35:20	11:35:27	7	1.0	23.0	3.0	21.0	40.092	35.361	21.0	5	1.3E-03	0.976	1.3E-03
1-14-19	11:35:27	11:35:35	8	3.0	21.0	5.0	19.0	35.361	30.629	21.0	5	1.3E-03	0.976	1.3E-03
1-14-19	11:35:35	11:35:44	9	5.0	19.0	7.0	17.0	30.629	25.897	21.0	5	1.4E-03	0.976	1.4E-03
1-14-19	11:35:44	11:35:55	11	7.0	17.0	9.0	15.0	25.897	21.166	21.0	5	1.4E-03	0.976	1.3E-03
				Pipet Length, cm	28.390	28.390								
				Pipet Volume, cc	24	24								
				Cross-sectional Area of Pipet, cm <sup>2</sup>	0.8454	0.8454								

**HYDRAULIC CONDUCTIVITY (K<sub>20°C</sub>) 1.3E-03 cm/sec**

# LIQUID AND PLASTIC LIMITS TEST REPORT

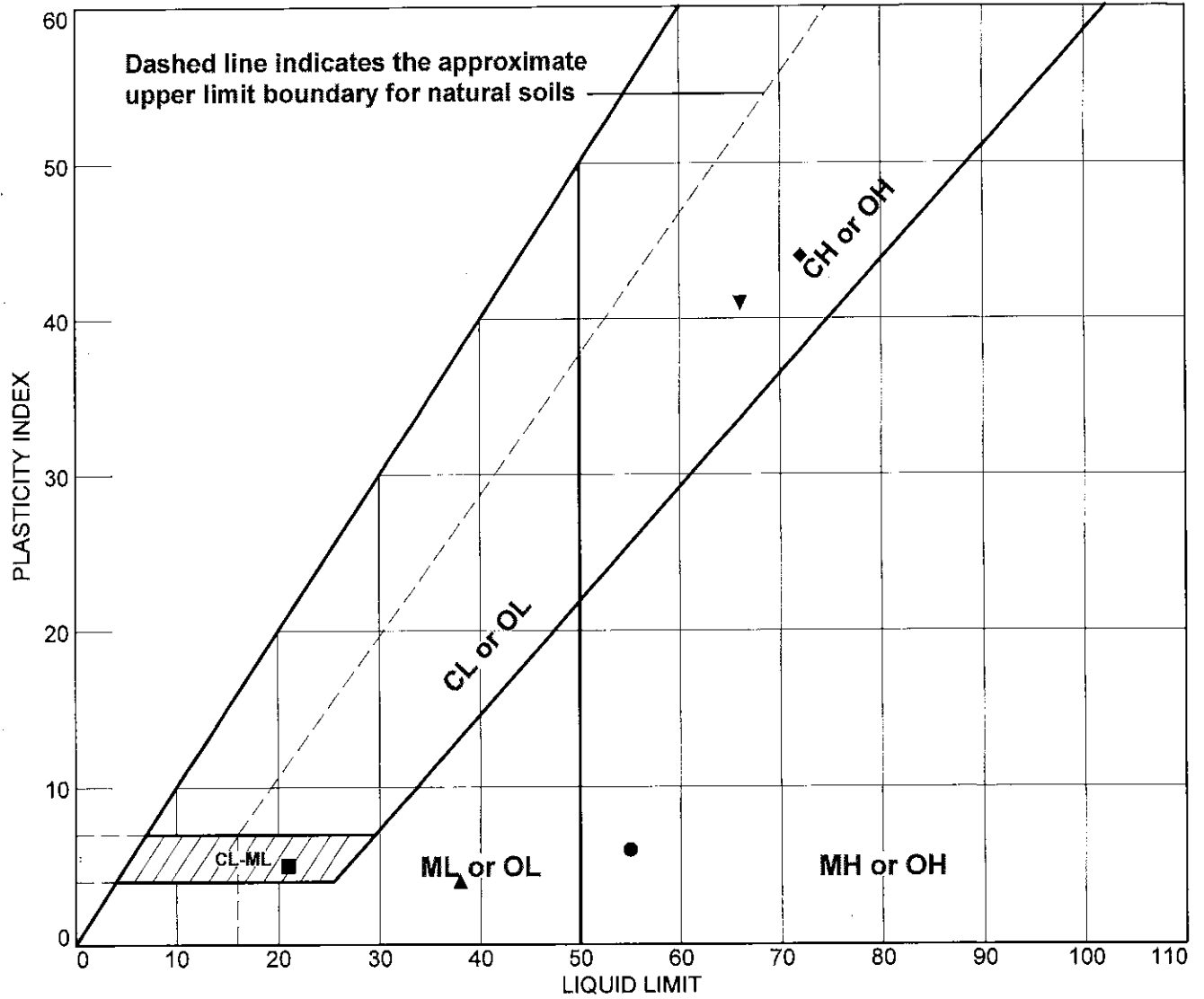

SOIL DATA								
SYMBOL	SOURCE	SAMPLE NO.	DEPTH	NATURAL WATER CONTENT (%)	PLASTIC LIMIT (%)	LIQUID LIMIT (%)	PLASTICITY INDEX (%)	USCS
●	Boring	PZ-14	1.0-2.5	53.3	49	55	6	SM
■	Boring	PZ-15	3.5-5.0	15.4	16	21	5	SC-SM
▲	Boring	PZ-15	18.5-20.0	18.5	34	38	4	SM
◆	Boring	PZ-16	1.5-4.0	27.1	28	72	44	CH
▼	Boring	PZ-17	3.0-5.0	27.1	25	66	41	CH

**Bunnell Lammons Engineering, Inc.**

**Client:** Greenpoint Landfill, LLC

**Project:** Greenpoint Landfill

**Greenville, SC**

**Project No.:** 11684-02

**Figure**

# LIQUID AND PLASTIC LIMITS TEST REPORT

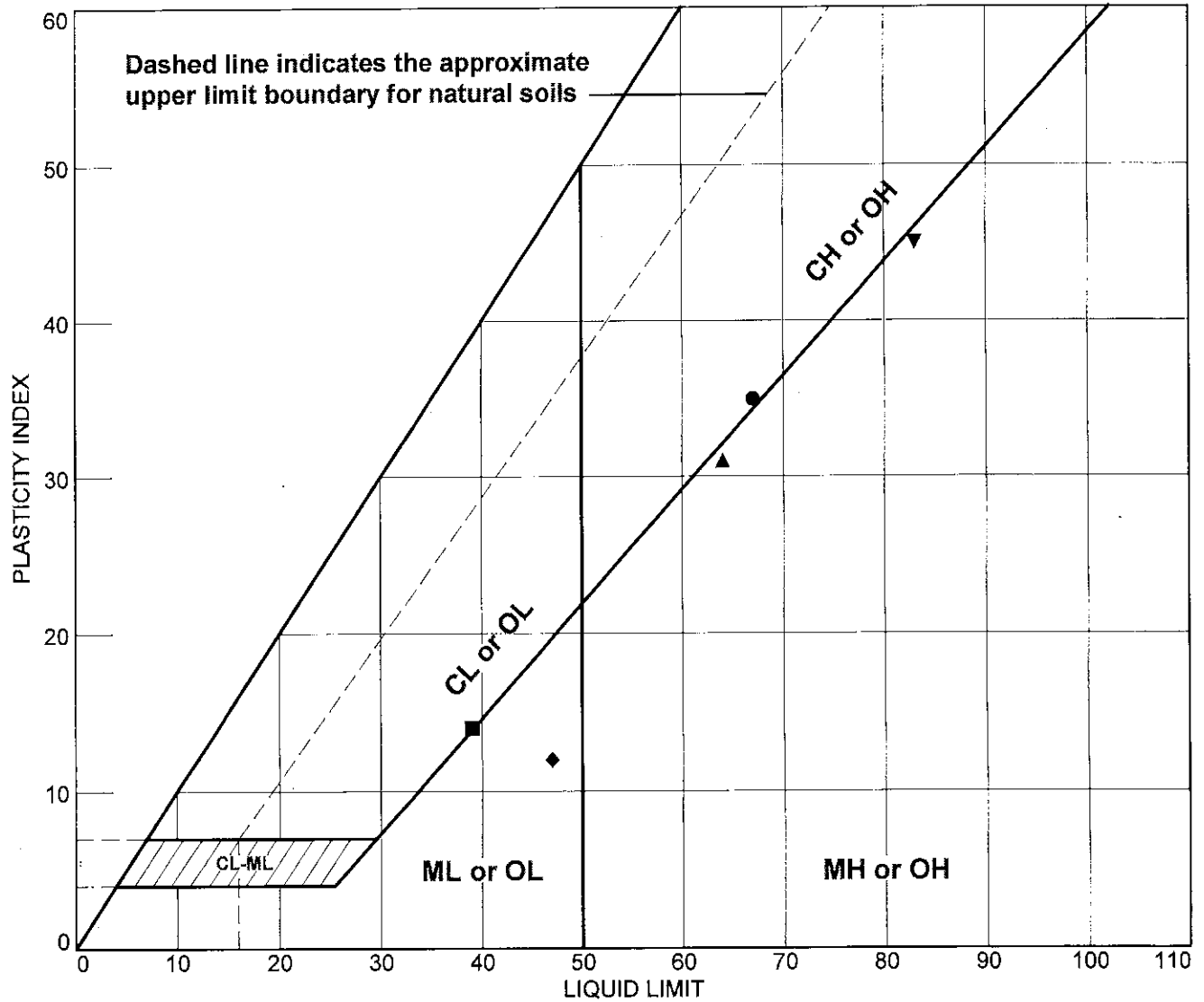

SOIL DATA								
SYMBOL	SOURCE	SAMPLE NO.	DEPTH	NATURAL WATER CONTENT (%)	PLASTIC LIMIT (%)	LIQUID LIMIT (%)	PLASTICITY INDEX (%)	USCS
●	Boring	PZ-18	6.0-7.5	26.5	32	67	35	CH
■	Boring	PZ-18	28.5-30.0	32.6	25	39	14	CL
▲	Boring	PZ-20	10.0-12.0	39.8	33	64	31	MH
◆	Boring	PZ-20	28.5-30.0	26.7	35	47	12	SM
▼	Boring	PZ-21	1.0-2.5	32.9	38	83	45	MH

**Bunnell Lammons Engineering, Inc.**

**Client:** Greenpoint Landfill, LLC

**Project:** Greenpoint Landfill

**Greenville, SC**

**Project No.:** 11684-02

**Figure**

# LIQUID AND PLASTIC LIMITS TEST REPORT

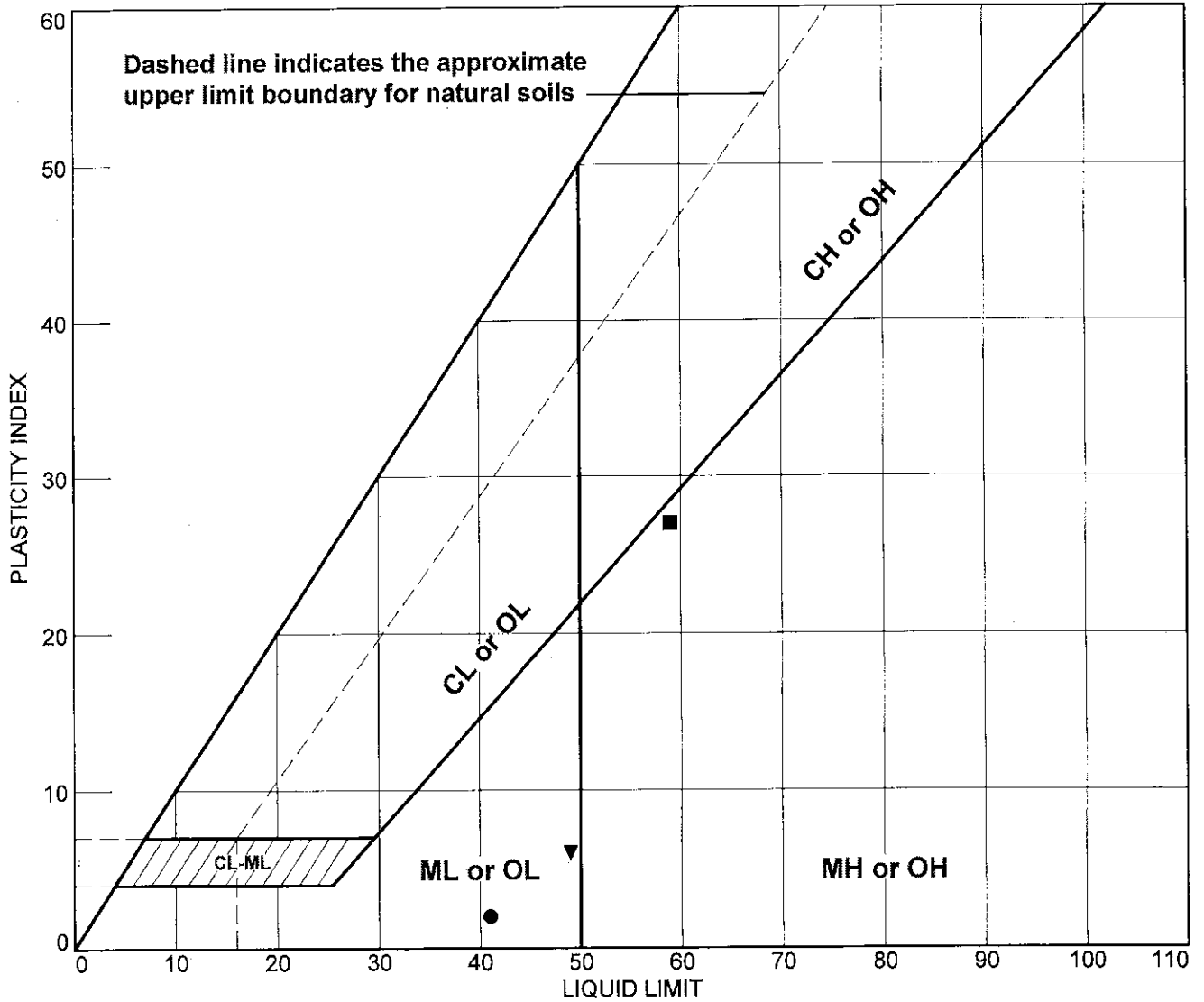

SOIL DATA								
SYMBOL	SOURCE	SAMPLE NO.	DEPTH	NATURAL WATER CONTENT (%)	PLASTIC LIMIT (%)	LIQUID LIMIT (%)	PLASTICITY INDEX (%)	USCS
●	Boring	PZ-22	3.5-5.5	11.5	39	41	2	SW-SM
■	Boring	PZ-23	6.0-7.5	25.8	32	59	27	SM
▲	Boring	PZ-24A	13.5-15.0	7.3	NP	NV	NP	SM
◆	Boring	PZ-24A	18.5-19.0	7.2	NP	28	NP	SM
▼	Boring	PZ-25	28.5-30.0	40.2	43	49	6	SM

**Bunnell Lammons Engineering, Inc.**

**Client:** Greenpoint Landfill, LLC

**Project:** Greenpoint Landfill

**Greenville, SC**

**Project No.:** 11684-02

**Figure**

# Particle Size Distribution Report

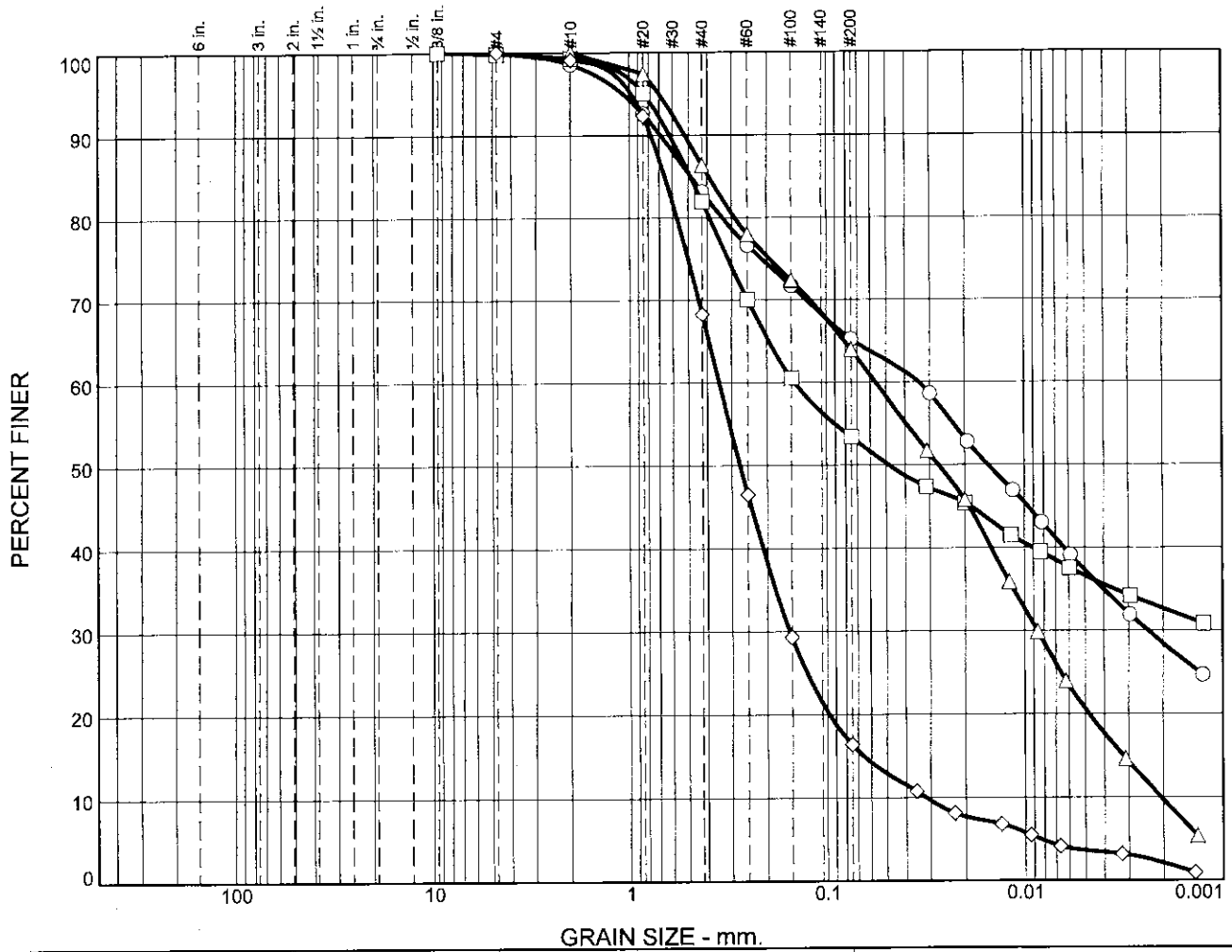

	% +3"	% Gravel		% Sand			% Fines	
		Coarse	Fine	Coarse	Medium	Fine	Silt	Clay
○	0.0	0.0	0.0	1.4	15.4	18.0	27.9	37.3
□	0.0	0.0	0.2	0.5	17.3	28.6	16.8	36.6
△	0.0	0.0	0.0	0.0	13.6	22.4	43.4	20.6
◇	0.0	0.0	0.0	0.9	30.8	51.9	12.8	3.6

SOIL DATA					
SYMBOL	SOURCE	SAMPLE NO.	DEPTH (ft.)	Material Description	USCS
○	Boring	PZ-16 A	2.0-4.0	Yellowish brown fi.-med. sandy elastic SILT	MH
□	Boring	PZ-17 A	3.0-5.0	Grey, yellow & brown fi.-med. sandy CLAY	CH
△	Boring	PZ-20 A	10.0-12.0	Yellow & brown fi.-med. sandy elastic SILT	MH
◇	Boring	PZ-22 A	3.0-5.0	Brown silty fi.-med. SAND	SM



# Particle Size Distribution Report

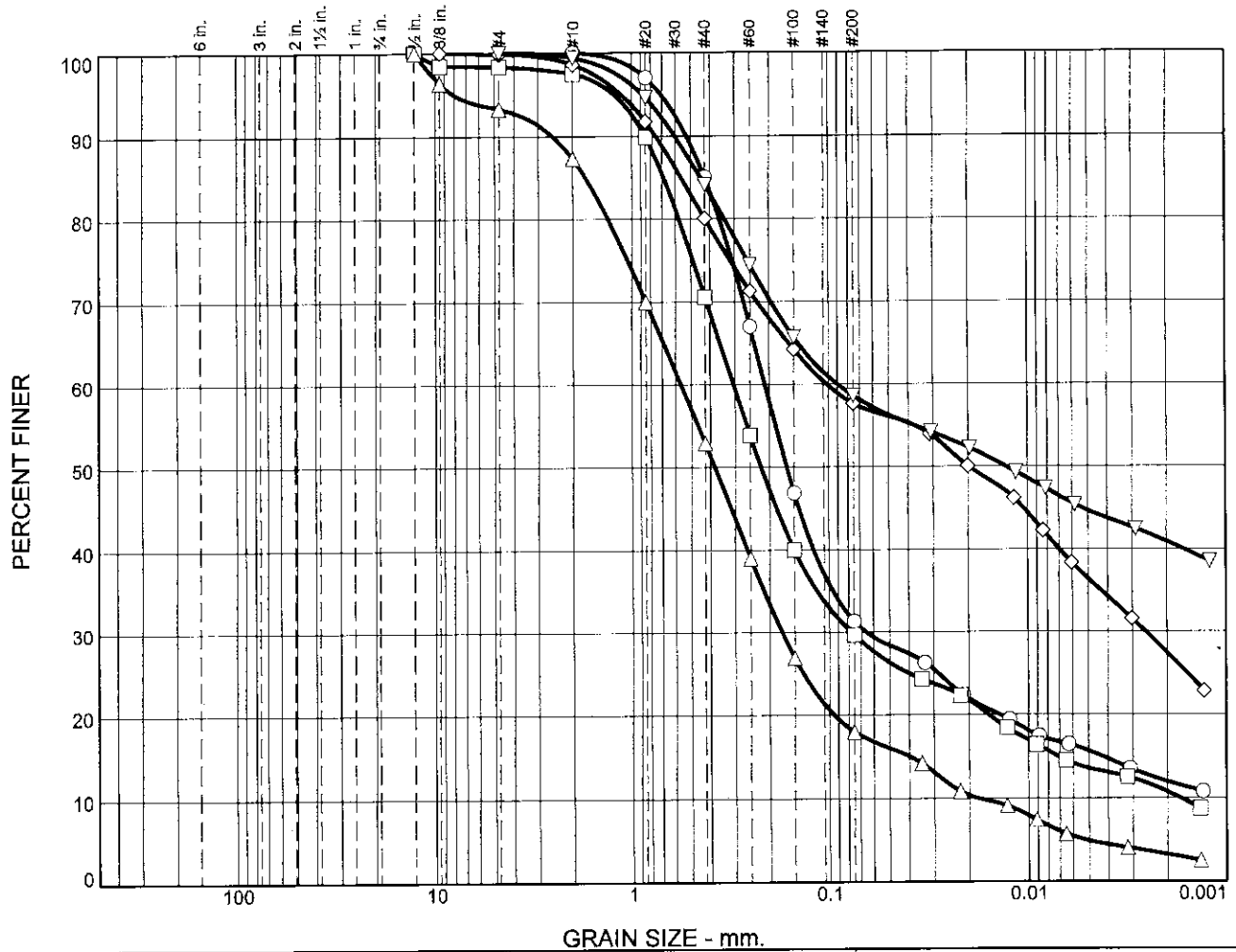

	% +3"	% Gravel		% Sand			% Fines	
		Coarse	Fine	Coarse	Medium	Fine	Silt	Clay
○	0.0	0.0	0.0	0.0	15.0	53.7	15.6	15.7
□	0.0	0.0	1.6	0.9	26.9	41.0	16.0	13.6
△	0.0	0.0	6.7	5.9	34.5	34.9	13.1	4.9
◇	0.0	0.0	0.2	1.2	18.5	22.5	21.2	36.4
▽	0.0	0.0	0.0	0.6	15.3	25.5	13.9	44.7

SOIL DATA					
SYMBOL	SOURCE	SAMPLE NO.	DEPTH (ft.)	Material Description	USCS
○	Boring	PZ-14	1.0-2.5	Dark brown silty fi.-med. SAND	SM
□	Boring	PZ-15	3.5-5.0	Brown & grey silty clayey fi.-med. SAND	SC-SM
△	Boring	PZ-15	18.5-20.0	Grey silty fi.-co. SAND	SM
◇	Boring	PZ-16	1.5-4.0	Grey & brown fi.-med. sandy CLAY	CH
▽	Boring	PZ-17	3.0-5.0	Grey & brown fi.-med. sandy CLAY	CH

# Particle Size Distribution Report

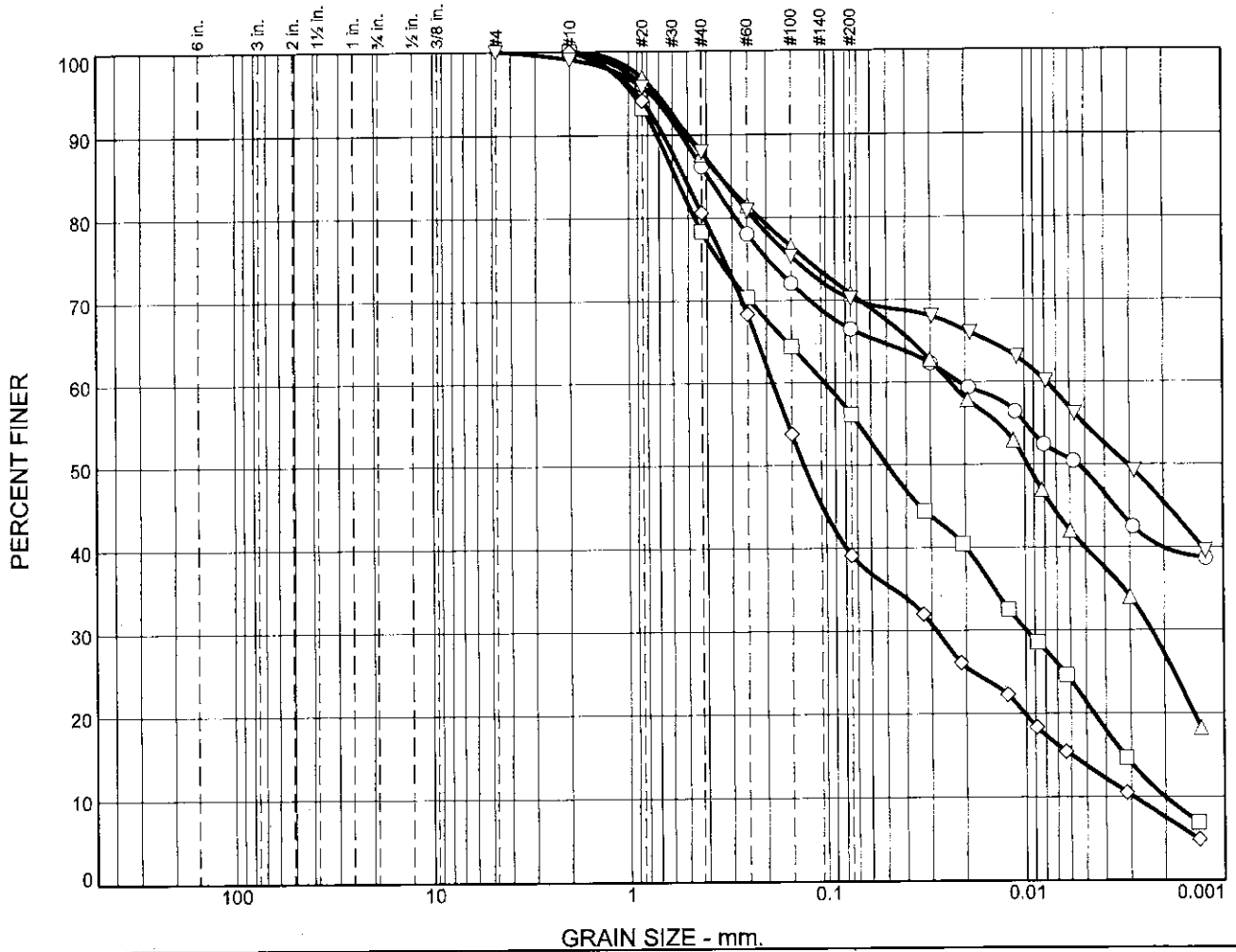

	% +3"	% Gravel		% Sand			% Fines	
		Coarse	Fine	Coarse	Medium	Fine	Silt	Clay
○	0.0	0.0	0.0	0.0	13.7	19.8	17.3	49.2
□	0.0	0.0	0.0	0.0	21.6	22.3	34.8	21.3
△	0.0	0.0	0.0	0.0	12.3	16.9	30.8	40.0
◇	0.0	0.0	0.0	0.0	19.4	41.4	25.5	13.7
▽	0.0	0.0	0.0	1.0	11.0	17.8	15.4	54.8

SOIL DATA					
SYMBOL	SOURCE	SAMPLE NO.	DEPTH (ft.)	Material Description	USCS
○	Boring	PZ-18	6.0-7.5	Reddish brown fi.-med. sandy CLAY	CH
□	Boring	PZ-18	28.5-30.0	Light brown fi.-med. sandy CLAY	CL
△	Boring	PZ-20	10.0-12.0	Yellowish brown fi.-med. sandy elastic SILT	MH
◇	Boring	PZ-20	28.5-30.0	White & brown silty fi.-med. SAND	SM
▽	Boring	PZ-21	1.0-2.5	Light grey & brown fi.-med. sandy elastic SILT	MH

# Particle Size Distribution Report

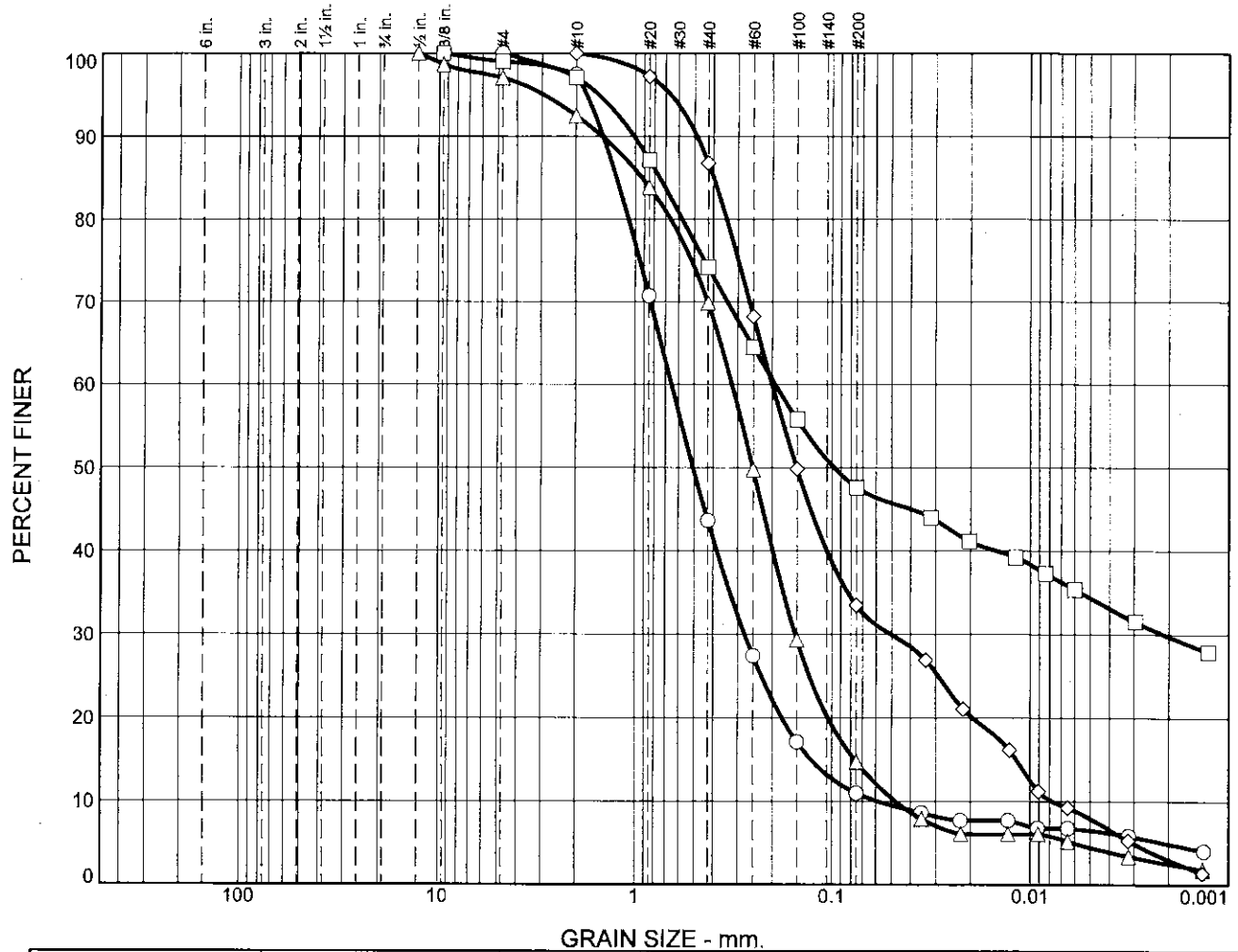

	% +3"	% Gravel		% Sand			% Fines	
		Coarse	Fine	Coarse	Medium	Fine	Silt	Clay
○	0.0	0.0	0.0	2.5	53.8	32.7	4.5	6.5
□	0.0	0.0	1.0	1.9	22.9	26.6	13.2	34.4
△	0.0	0.0	3.0	4.5	22.6	55.2	10.2	4.5
◇	0.0	0.0	0.0	0.0	13.2	53.3	25.5	8.0

SOIL DATA					
SYMBOL	SOURCE	SAMPLE NO.	DEPTH (ft.)	Material Description	USCS
○	Boring	PZ-22	3.5-5.5	Brown silty fi.-med. SAND	SW-SM
□	Boring	PZ-23	6.0-7.5	Reddish brown silty fi.-med. SAND	SM
△	Boring	PZ-24	13.5-14.0	Grey silty fi.-med. SAND	SM
◇	Boring	PZ-25	28.5-30.0	Dark brown silty fi.-med. SAND	SM

**ENGINEERING REPORT**

**COMPREHENSIVE STORMWATER POLLUTION  
PREVENTION PLAN (C-SWPPP)**

**FOR THE**

**GREENPOINTE CONSTRUCTION & DEMOLITION  
LANDFILL EXPANSION**

**LOCATED IN  
ANDERSON COUNTY, SOUTH CAROLINA**

**Wasteco, Inc.**

**June 2019**

**ENGINEERING REPORT**

**COMPREHENSIVE STORMWATER POLLUTION  
PREVENTION PLAN (C-SWPPP)**

**FOR THE**

**GREENPOINTE CONSTRUCTION & DEMOLITION  
LANDFILL EXPANSION**

**LOCATED IN  
ANDERSON COUNTY, SOUTH CAROLINA**

**Wasteco, Inc.**

**Prepared For:**  
Wasteco, Inc.  
500 Hamlin Road  
Easley, South Carolina 29642

**Prepared By:**  
**Alliance Consulting Engineers, Inc.**  
124 Verdae Blvd., Suite 505  
Charlotte, North Carolina 28217-2750

Project Number 16227-0004  
June 2019

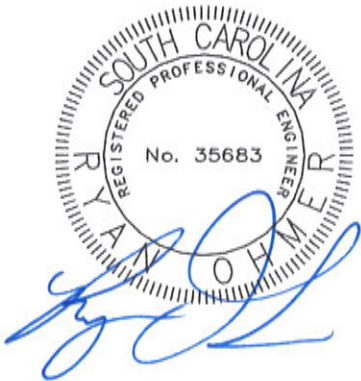

**TABLE OF CONTENTS**

1.0 Project Overview .....1

    1.1 Narrative .....1

    1.2 Stormwater Management and Sediment Control.....8

    1.3 Sequence of Construction.....11

    1.4 Non-Numeric Effluent Limits .....12

    1.5 Management of Non-Stormwater Discharge .....12

    1.6 Post-Construction Water Quality Measures .....13

    1.7 Buffer Zone Management.....13

    1.8 Certification Statement .....14

2.0 Site Features and Sensitive Areas .....23

    2.1 Sources of Pollution .....23

    2.2 Surface Waters.....24

3.0 Compliance Requirements .....25

    3.1 SWPPP Availability .....25

    3.2 Pre-Construction Conference .....25

    3.3 Inspection Requirements .....25

    3.4 Maintenance Policies .....26

    3.5 Record Keeping .....26

    3.6 Final Stabilization.....27

**LIST OF EXHIBITS**

Exhibit A Erosion and Sediment Control Plan .....15

**LIST OF TABLES**

Table 1A - Pre and Post Developed Peak Flows for DA 1.1 .....3

Table 1B - Pre and Post Developed Peak Flows for DA 1.2 .....3

Table 1C - Pre and Post Developed Peak Flows for DA 2.1 .....3

Table 2 - Locations of Potential Sources of Stormwater Contamination .....11

Table 3 - Potential Construction Site Stormwater Pollutants .....23

**APPENDICES**

APPENDIX A Site Maps .....28

APPENDIX B Pre and Post Development Maps .....35

APPENDIX C Pre-Development – Previously Permitted Calculations and HydroCAD .....40

APPENDIX D Post-Development – HydroCAD .....153

APPENDIX E Perimeter Drainage, Slope Conveyance, and Storm Drainage Pipes .....199

APPENDIX F Additional Calculations .....223

## 1.0 Project Overview

### 1.1 Narrative

Wasteco, Inc. is proposing the expansion of the Greenpointe Construction and Debris (C&D) Landfill, which consists of construction of a new approximately 8.02 acre (AC) expansion to the existing 21.60 AC Cell 1 C&D Landfill, a new approximately 17.77 AC C&D Cell 2, and a gravel access road located along Hamlin Road in Anderson County, South Carolina. The property (TMS # 164-00-02-036 and 138-00-04-013) is located approximately one (1) mile west of exit 35 on interstate I-85 in Anderson County, as illustrated in the Site Location Map in **Appendix A**. The proposed development will include approximately 66.8 AC of land disturbance of the approximately 212.5 AC site.

The Anderson County Digital Ortho Quarter Quadrangle (DOQQ) imagery provided by the United States Department of Agriculture Farm Service Agency (USDA-FSA) (See Aerial Map in **Appendix A**) was utilized to provide a general overview of the site and its surroundings. Expansion of Cell 1 and Cell 2 of the site consists of wooded, newly graded, grass, brush, impervious, and gravel areas. The United States Geological Survey's (USGS) 7.5 Minute Anderson County Quad Map (See Topographic Map in **Appendix A**) was utilized to provide a general overview of the site and surrounding area drainage patterns. Utilizing a topographic survey conducted by F&S Surveyors, Engineers, & Planners, Inc. dated February 8, 2017, it appears that a majority of the stormwater runoff is to one (1) discharge point along the southeastern portion of the property line at Pickens Creek. Based on a review of the South Carolina Soil Survey for Anderson County it is apparent that Cartecay (Ca) hydrologic soil group (HSG) B/D, Cecil (CdB, CdC, CdD, CeC2) HSG B, Hiwassee (HaC) HSG B, and Madison (MaC, MaD, MaE) HSG B soil comprises the project site (See Soils Map in **Appendix A**). The Federal Emergency Management Agency (FEMA) Flood Map Panels 45007C0040E, 45007C0110E, 45007C0130E, 45077C295D, 45077C0315D, and 45077C0410D dated 2011 (See FEMA Flood Map in **Appendix A**) identifies that the project site is located within the floodzone, which indicates the site is in an area of flooding and is inside of the 100-year Flood Plain. Based on the provided base flood elevations shown on the FEMA Map, the project site will not disturb this flood zone area. The National Wetlands Inventory (NWI) Map provided by the US Fish and Wildlife Service (See NWI Map in **Appendix A**), indicates there is one (1) creek (Pickens Creek) that borders the site from east to west transversing the property site. This creek has been delineated and is shown on the Construction Plans.

The proposed landfill expansion will include the construction of the approximately 8.02 AC expansion to the existing 21.60 AC Cell 1 C&D Landfill, a new approximately 17.77 AC C&D Cell 2, and a gravel access road. All earth moving activities will tie into existing grade and will maintain the existing flow patterns of stormwater on-site. The proposed development's stormwater



will be routed into three (3) detention basins (See Maps in **Appendix B**). There are currently two (2) detention basins (Detention Basin 1 and 2) on-site. The existing Detention Basin 1 will remain, Detention Basin 2 will be expanded, and a new detention basin (Detention Basin 3) will be constructed. The existing, expanded and new detention basins have approximately 1,306,766 cubic-feet of combined storage and are located along the southeastern portion of the property.

**Appendix B**, Pre-Development Watershed Map, illustrates the locations of the pre-development watershed areas totaling 78.28 AC for existing Cell 1, expansion of Cell 1, and proposed Cell 2 landfills. The hydraulic calculations for the existing Cell 1 C&D landfill development of the site were performed to compare to the design release rates shown in the previous report (see Appendix C for calculations). The existing Cell 1 C&D Landfill was approved and permitted separately in 2008 under permit LF2-001 (see Appendix C for calculations).

Three (3) existing study points were observed for this site. Drainage Area 1.1 (DA 1.1) is approximately 15.0 AC which contains good-wooded and fair-brush areas. The Discharge Point DA 1.1 is out of the existing Detention Basin 1, which continues in the southerly direction to discharge at Pickens Creek. Drainage Area 1.2 (DA 1.2) is approximately 13.0 acres which contains fair-brush, gravel, and newly graded soil areas. The Discharge Point DA 1.2 Outfall is at the existing Detention Basin 2, which continues in the southerly direction to discharge at Pickens Creek. Drainage Area 2.1 (DA 2.1) is approximately 40.78 AC which contains good-wooded area and fair-brush area. The analysis area DA 2.1 is the area of Cell 2 draining southwest to the wetlands and southeast into Pickens Creek.

**Appendix B**, Post Development Watershed Map, illustrates the location of the post-development watershed areas and the apparent stormwater drainage patterns. The existing three (3) DAs are subdivided into four (4) DAs.

DA 1.1 is approximately 17.34 AC size and is routed to the existing Detention Basin 1, which drains into DA 1.1 Outfall. DA 1.2 is approximately 27.61 AC in size and is routed to the new expansion of Detention Basin 2, which drains into DA 1.2 Outfall. This drainage area contains proposed impervious surface, gravel, newly graded soil, fair-grass, and good-woods for the new Cell 1 expansion.

DA 2.1 splits into DA 2.1 and DA 2.1 Bypass. DA 2.1 is approximately 23.38 AC in size and is routed to the new Detention Basin 3, which discharges into DA 2.1 Outfall. DA 2.1 Bypass is approximately 17.41 AC in size and bypasses into the discharge point DA 2.1 Outfall. This drainage area contains proposed newly graded soils, impervious surfaces, and gravel for the Cell 2 C&D landfill. The peak flows from the DA 2.1 to the new Detention Basin 3 and DA 2.1 Bypass are combined at DA 2.1 Discharge Point for the total post development discharge rates.

The Stormwater Calculations conducted by Alliance Consulting Engineers, Inc. modeled the overall development utilizing the HydraCAD® Software. This program utilized the SCS method for generating hydrographs, in accordance with South Carolina state regulations. The pre-developed peak flows and post-developed peak flows for study points DA 1.1, 1.2, and 2.1 Outfall can be seen in **Table 1A-1C**. DA 1.1 and 1.2 studies the point of discharge from Detention Basins 1 and 2. DA 2.1 studies the discharge into Pickens Creek from the Detention Basin 3 and bypass at Cell 2. The post-developed flows are required to be less than the pre-developed flows up through the 25-yr, 24-hr storm event per Anderson County requirements. As shown in the tables below, the proposed post-development conditions control up through the 25-yr storm event, with the post-development rates for Cell 1 being below the previously approved 2-yr, 10-yr, and 25-yr basin discharge rates of permit LF2-001 (see Appendix G). DA 1.2 2-yr. has an increase of 0.14 cfs in flow, due to the necessity to meet the required maximum drawdown time of five (5) days. Note that this slight increase is still below the pre-development peak flow rates in the attached approved report, LF2-001 (see Appendix G).

**Table 1A – Previous Design and Post Developed Peak Flows for DA 1.1**

Return Period	Pre-Dev. Peak Flow (CFS)	Post-Dev. Peak Flow (CFS)	Flow Change (CFS) (-)
2 yr, 24-hr	0.77	0.60	-0.17
10 yr, 24-hr	0.97	0.81	-0.16
25 yr, 24-hr	2.63	2.52	-0.11

**Table 1B- Previous Design and Post Developed Peak Flows for DA 1.2**

Return Period	Pre-Dev. Peak Flow (CFS)	Post-Dev. Peak Flow (CFS)	Flow Change (CFS) (-)
2 yr, 24-hr	0.99	1.13	0.14
10 yr, 24-hr	1.28	1.24	-0.04
25 yr, 24-hr	5.79	3.57	-2.22

**Table 1C - Pre and Post Developed Peak Flows for DA 2.1**

Return Period	Pre-Dev. Peak Flow (CFS)	Post-Dev. Peak Flow (CFS)	Flow Change (CFS) (-)
2 yr, 24-hr	11.91	10.21	-1.70
10 yr, 24-hr	53.17	47.67	-5.50
25 yr, 24-hr	83.76	79.59	-4.17

Water quality will be provided for this project by the use of skimmers sized for a drawdown of one (1) day for the water quality volume. Sheets C-8.0-8.1 of the Construction Plans includes the details and cross-sections for the detention ponds and skimmers.

Stormwater runoff in DA 2.1 Bypass will have the same good condition of stabilized and wooded areas to flow through in the proposed Post-Development conditions just as it did in the Pre-Development prior to entering the existing creek bed. Therefore, no controls are proposed for the DA 2.1 Bypass area.

All rip-rap berms were designed and located where the stormwater enters the proposed detention basins. The location were selected to provide 20% of the sediment storage in the forebays up to the crests of the berms. The locations and dimensions of the proposed three (3) rip-rap berms are shown on the Storm Drain Details (Sheet C-8.1). In addition, coir baffles and one (1) 6-inch skimmer for Detention Basin 1, one (1) 8-inch skimmer for Detention Basin 2, and two (2) 5-inch skimmers for Detention Basin 3 shall be placed within the detention basins during construction. The skimmer sizes were designed to drain the 10-year storm event volume at a minimum of 24 hours. The skimmer sizing information is shown on Sheet C-8.0 of the Storm Drain Details.

#### Volume and Drawdown Calculations for Existing Detention Basin #1

D.A. = 17.34 acres

Sediment Storage Required: 3600 cubic feet (CF) x 17.34 acres (AC) = 62,424 CF

Forebay Volume Required: 62,424 CF x 0.2 = 12,485 CF

Forebay Volume Provided: **13,177 CF** as shown on the plans

First Flush Volume = (17.34 AC x 43,560 SF/AC) x (1" / 12" per foot) = 62,944 CF

The actual provided water quality volume is 187,729 CF at elevation 809.92 in Detention Basin 1. Using a Faircloth Skimmer, the skimmer size needed to drawdown this volume in a minimum 24 hours is a 6", which will drawdown 51,840 CF in a 24-hr period. This is a drawdown rate of:

$51,840 \text{ CF} / (24 \text{ hr} \times 3600 \text{ sec/hr}) = 0.6 \text{ cfs}$

This drawdown rate will be utilized as the pond discharge rate below the top of the first outlet control in the outlet structure in the following design.

*First Flush drawdown time:*

First Flush Volume = 62,944 CF

Drawdown time =  $62,944 \text{ CF} / (0.6 \text{ cfs} \times 3600 \text{ sec} / \text{hr}) \times (1 \text{ day} / 24 \text{ hr}) = \mathbf{1.21 \text{ days}}$

*10-yr drawdown time:*

Maximum storage volume in pond = 192,473 CF (see attached Hydraflow Reports, **Appendix D**)  
Occurs at hour 24.03 and elevations 810.03 and draws down to elevation 809.92 at hour 26.10.

Remaining Drawdown time =  $187,729 \text{ CF} / (0.6 \text{ cfs} \times 3600 \text{ sec} / \text{hr}) \times (1 \text{ day} / 24 \text{ hr}) = \mathbf{3.62 \text{ days}}$

This results in a total retention time of =  $3.62 \text{ days} + 1.09 \text{ days} = \mathbf{4.71 \text{ days}}$

Running Hydraflow for this sediment basin with a contributing area of bare soil (CN = 86) and the average flow rate of the skimmer given for the Faircloth Skimmer, the peak elevation in the basin will be at 810.03 with a peak flow of 0.81 cfs for the 10-yr storm event which is below the crest of the riser (810.50) and crest of the emergency spillway (811.00). From the South Carolina Department of Health and Environmental Control (SCDHEC) Trapping Efficiency Figure this basin will provide 91.52% trapping efficiency (see attached Sediment Basin Trapping Efficiency summary, **Appendix F**).

#### Volume and Drawdown Calculations for Detention Basin #2

D.A. = 27.61 AC

Sediment Storage Required:  $3600 \text{ CF} \times 27.61 \text{ AC} = 99,396 \text{ CF}$

Forebay Volume Required:  $99,396 \text{ CF} \times 0.2 = 19,879 \text{ CF}$

Of the 27.61 acres of run-off being routed to Detention Basin 2 by the perimeter diversions 9.66 acres is routed to Forebay B and 17.95 acres is routed to Forebay A. Therefore, 65% of the forebay volume (12,922 CF) must be contained within Forebay A and 35% (6,958 CF) must be contained within Forebay B.

Forebay A Volume Provided: **17,315 CF** as shown on the plans

Forebay B Volume Provided: **7,986 CF** as shown on the plans

First Flush Volume =  $(27.61 \text{ AC} \times 43,560 \text{ SF/AC}) \times (1'' / 12'' \text{ per foot}) = 100,224 \text{ CF}$

The actual provided water quality volume is 294,075 CF at elevation 804.50 in the detention basin 2. Using a Faircloth Skimmer, the skimmer size needed to drawdown this volume in a minimum 24 hours is an 8", which will drawdown 97,978 CF in a 24 hour period.

This is a drawdown rate of:

$$97,978 \text{ CF} / (24 \text{ hr} \times 3600 \text{ sec/hr}) = 1.13 \text{ cfs}$$

This drawdown rate will be utilized as the pond discharge rate below the top of the first outlet control in the outlet structure in the following design.

*First Flush drawdown time:*

$$\text{First Flush Volume} = 100,224 \text{ CF}$$

$$\text{Drawdown time} = 100,224 \text{ CF} / (1.13 \text{ cfs} \times 3600 \text{ sec / hr}) \times (1 \text{ day} / 24 \text{ hr}) = \mathbf{1.03 \text{ days}}$$

*10-yr drawdown time:*

Maximum storage volume in pond = 298,651 CF (see attached Hydraflow Reports, **Appendix D**)  
Occurs at hour 24.03 and elevation 804.55 and draws down to elevation 804.55 at hour 25.2.

$$\text{Drawdown time} = 294,075 \text{ CF} / (1.13 \text{ cfs} \times 3600 \text{ sec / hr}) \times (1 \text{ day} / 24 \text{ hr}) = \mathbf{3.01 \text{ days}}$$

This results in a total retention time of = 3.01 days + 1.05 days = **4.06 days**

Running Hydraflow for this sediment basin with a contributing area of bare soil (CN = 86) and the average flow rate of the skimmer given for the Faircloth Skimmer, the peak elevation in the basin will be at 804.55 with a peak flow of 1.24 cfs for the 10-yr storm event which is below the crest of the riser (805.00) and crest of the emergency spillway (805.75). From the SCDHEC Trapping Efficiency Figure this basin will provide 92.49% trapping efficiency (see attached Sediment Basin Trapping Efficiency summary, **Appendix F**).

### Volume and Drawdown Calculations for proposed Detention Basin #3

$$\text{D.A.} = 23.38 \text{ AC}$$

$$\text{Sediment Storage Required: } 3600 \text{ CF} \times 23.38 \text{ AC} = 84,168 \text{ CF}$$

$$\text{Forebay Volume Required: } 84,168 \text{ CF} \times 0.2 = 16,834 \text{ CF}$$

Forebay Volume Provided: **18,758 CF** as shown on the plans

$$\text{First Flush Volume} = (23.38 \text{ AC} \times 43,560 \text{ SF/AC}) \times (1'' / 12'' \text{ per foot}) = 84,869 \text{ CF}$$

The actual provided water quality volume is 91,308 CF at elevation 805.80 in Detention Basin 3. Using a Faircloth Skimmer, the skimmer size needed to drawdown this volume in a

minimum 24 hours is a two (2) 5", which will drawdown 65,664 CF in a 24-hr period. This is a drawdown rate of:

$$65,664 \text{ CF} / (24 \text{ hr} \times 3600 \text{ sec/hr}) = 0.76 \text{ cfs}$$

This drawdown rate will be utilized as the pond discharge rate below the top of the first outlet control in the outlet structure in the following design.

*First Flush drawdown time:*

First Flush Volume = 84,869 CF

$$\text{Drawdown time} = 84,869 \text{ CF} / (0.76 \text{ cfs} \times 3600 \text{ sec/hr}) \times (1 \text{ day} / 24 \text{ hr}) = \mathbf{1.29 \text{ days}}$$

*10-yr drawdown time:*

Maximum storage volume in pond = 153,964 CF (see attached Hydraflow Reports, **Appendix D**)

Occurs at hour 12.27 at elevation 807.19 and draws down to the water quality volume provided at hour 24.90.

$$\text{Drawdown time} = 91,308 \text{ CF} / (0.76 \text{ cfs} \times 3600 \text{ sec/hr}) \times (1 \text{ day} / 24 \text{ hr}) = \mathbf{1.39 \text{ days}}$$

This results in a total retention time of 1.29 days + 1.39 days = **2.68 days**

Running Hydraflow for this sediment basin with a contributing area of bare soil (CN = 86) and the average flow rate of the skimmer given for the Faircloth Skimmer, the peak elevation in the basin will be at 807.19 with a peak flow of 16.55 cfs for the 10-yr storm event which is below the crest of the riser (808.00) and crest of the emergency spillway (808.50). From the SCDHEC Trapping Efficiency Figure this basin will provide 84.10% trapping efficiency (see attached Sediment Basin Trapping Efficiency summary, **Appendix F**) which is above the required 80.0% trapping efficiency.

The proposed storm drainage system was modeled in Autodesk® Storm and Sanitary Analysis Software. This program utilized the Rational Method in order to ensure the proposed pipe networks function properly. The storm drainage systems were sized to handle the 10-year storm event without having any surcharging conditions within the pipes. The 10-year storm event output of this model can be referenced in **Appendix E**, refer to the drainage maps as well.

The proposed slope conveyance systems and perimeter ditches were modeled using in Autodesk® Hydraflow Express Extension. This program utilized the Rational Method in order to ensure the proposed slope conveyance systems and perimeter ditches function properly.

The slope conveyance systems were sized to handle the 25-year storm event without having any surcharging conditions within the system. The largest drainage area was used to design all the slope conveyances and indicate the cross-section parameters. The 25-year storm event output of this model can be referenced in **Appendix E**, refer to the Slope Drainage Maps as well.

The perimeter ditches were sized to handle the 25-year storm event without having any surcharging conditions within the ditches. The perimeter ditches were sized from the analysis point for the entire ditch. The 25-year storm event output of this model can be referenced in **Appendix E**, refer to the Perimeter Ditch Drainage Maps as well.

Excavation and backfilling for site grading of the proposed development will be the primary soil disturbing activities. Excavated soils not immediately utilized in backfilling will be stockpiled and protected on site and then finish graded just before final stabilization. All exposed soils will be reseeded and new vegetation will be planted as soon as practical.

## 1.2 Stormwater Management and Sediment Control

### o Water Quality BMPs

The locations of best management practices (BMPs) are illustrated in **Exhibit A**.

To prevent soil from washing into the undisturbed areas of the site, the following site-wide BMPs will be implemented:

- Single Row and/or Double Row silt fencing will be placed along the perimeter of the areas to be cleared and graded before any clearing or grading takes place.
- Construction Entrance/Exit will be placed at the designated entrance.
- Inlet protections will be used at the proposed inlets where necessary.
- BMPs will be inspected every seven (7) calendar days.
- The detention basins equipped with rip-rap berm, skimmer(s), and baffles will capture runoff from construction areas.

The post construction water quality for the proposed development will be treated within the new detention basins, where runoff is captured into the new storm drainage system. Calculations above should be referenced for the water quality volumes.

### ○ Erosion Prevention BMPs

The locations of best management practices (BMPs) have been illustrated in **Exhibit A**. Several of the BMPs included in this plan have been developed to serve as post-construction stormwater controls.

To prevent soil from washing onto the undisturbed areas of the site or off-site, the following erosion prevention BMPs will be implemented and remain in place until the cells are closed out and meet final stabilization requirements:

- As each phase of the landfill is brought to finished grade, that portion of the cell will be brought to final stabilization.
- After fertilizing these areas will be seeded. The permanent seed mix for March to August planting dates shall consist of Annual Rye Grass, Hulled Bermuda, Pensacola Bahia, Sericea Lespedeza, and Weeping Love Grass. The permanent seed mix for September to February planting dates shall consist of Annual Rye Grass, Hulled Bermuda, Brown Top Millet, and Unhulled Bermuda. Seeding rates shall conform to the grassing specifications approved for the Project and/or to the seeding rates illustrated on the Construction Details for Anderson County.
- Cleared and graded soils and slope drains provided will be sloped as indicated on the Grading Plans (**Sheet C-4.0-4.10**).
- Grassing, erosion control matting, and turf reinforcement matting will be placed at the appropriate locations as indicated on the Erosion and Sediment Control Plan (**Sheets C-5.0 – C-5.4**).
- Outlet protection will be installed at pipe outlets.
- A visual inspection of active landfill sites will occur at least every seven (7) calendar days by landfill personnel for areas of open landfill application;
- A visual inspection will occur every thirty (30) calendar days for stabilized sites to ensure that sediment and erosion control measures are operating properly.

### ○ Construction Debris Management

Waste materials will be handled and disposed of per guidelines and requirements of this landfill permit and the following preventative measures:

- Fertilizers will be applied only in the minimum amounts recommended by the manufacturer.
- Fertilizers will be worked into the soil to limit exposure to stormwater.
- Fertilizers will be stored and covered, and partially used bags will be transferred to a sealable bin to avoid spills.
- Vehicles on site will be monitored for leaks and receive regular preventive maintenance to reduce the chance of leakage.
- Petroleum products will be stored in tightly sealed containers which are clearly labeled.



- Spill kits will be included with all fueling sources and maintenance activities.
  - Sanitary waste will be collected from portable units as necessary to avoid overfilling.
  - A covered receptacle will be used for all waste materials.
  - Materials and equipment necessary for spill cleanup will be kept on site. Equipment will include, but not be limited to, brooms, dust pans, mops, rags, gloves, goggles, kitty litter, sand, sawdust, and plastic and metal trash containers.
  - Spills will be cleaned up immediately upon discovery. Spills large enough to reach the storm drain collection system will be reported to the National Response Center at (800) 424-8802.
  - A stabilized construction entrance with a filter fabric liner will be constructed to reduce vehicle tracking of sediments.
  - Dump trucks hauling material from the construction site will be covered with a tarp.
- **Construction Entrances and Dust Control**

The contractor is to use the designated construction entrance as shown. The contractor will be instructed to protect and maintain entrances at all times and in accordance with the Erosion Control Details. The gravel construction entrance will be maintained and reworked with additional stone as needed. Traffic entering or exiting each parking lot will be directed through the construction entrance. A water truck will be called on site to water soil as necessary to minimize dust.

○ **Additional Onsite and Offsite Pollution Identification**

The following potential source areas of stormwater contamination were identified and evaluated:

- Cleared and graded areas;
- Construction site entrance;
- Undisturbed areas; and
- Construction debris.

**Table 2** and Exhibit A presents site specific information regarding stormwater pollution potential from each of these areas.

**Table 2 - Locations of Potential Sources of Stormwater Contamination**

<i>Sub-Watershed Area<sup>(1)</sup></i>	<i>Potential Stormwater Contamination Point</i>	<i>Potential Pollutants</i>	<i>Potential Problem</i>
<i>All Post Watersheds</i>	<i>Cleared and graded areas; Construction debris</i>	<i>Soil erosion, fertilizer, pesticides</i>	<i>Erosion of soils from cleared and graded areas have the potential to discharge into the proposed detention basin</i>
<i>DA 1.1</i>	<i>Construction site entrance</i>	<i>Hydraulic oil, gasoline, antifreeze, soil erosion, fertilizer, pesticides</i>	<i>Leaking hydraulic oil and antifreeze from clearing and grading equipment. Gasoline and diesel fuel spills while fueling construction equipment, and erosion of exposed and stockpiled soils. Tracking of soil into the road through the construction site entrance.</i>
<i>DA 1.1, 1.2, and 2.1</i>	<i>Proposed inlets</i>	<i>Soil erosion, fertilizer, pesticides, hydraulic oil, gasoline, antifreeze</i>	<i>Erosion of soils from cleared and graded areas have the potential to discharge into the proposed storm drainage system. Leaking hydraulic oil and antifreeze from vehicles and equipment from the construction site entrance.</i>
<i>None</i>	<i>All undisturbed areas</i>	<i>None</i>	<i>No storm water related issues with this completely vegetated area.</i>

(1) See Appendix B for drainage areas

### 1.3 Sequence of Construction

Structural BMPs will be coordinated with construction activities so the BMP is in place before construction begins. A full construction sequence for this project is shown on the Erosion Control Plan (Sheet C-5.0 - C-5.4) within the Construction Plans for this project. The following BMPs will be coordinated with construction activities:

- A Preconstruction Meeting will be held for this project per SCDHEC’s review process.
- The limits of disturbance and any portion of the 50’ wetland buffer outside the limits of disturbance will need to be flagged.
- The temporary perimeter controls (silt fences) will be installed before any clearing and grading begins.
- The new construction entrance/exit entrances will be installed before any clearing and grading begins.

- The new detention basins will be in place with all during construction measures prior to clearing and grading the remainder of the site.
- Clearing and grading will not occur in an area until it is necessary for construction to proceed.
- Once construction activity ceases permanently in an area, that area will be stabilized with matting and grass seed as indicated in the Construction Documents.
- The temporary perimeter controls (silt fencing) will not be removed until all construction activities at the site are complete and soils have been permanently stabilized.
- Sediment basins will remain in place until the landfill is closed out and authorization from SCDHEC is granted to remove them.

#### 1.4 Non-Numeric Effluent Limits

Stormwater volume and velocity control within the site will be accomplished during construction activities to minimize erosion. This will be accomplished through the use of the following BMPs and techniques:

- Limiting the amount of disturbed area not stabilized at a time;
- Phased construction sequence;
- Diverting off-site flow around the site;
- Controlling drainage patterns within the construction site;
- Surface roughening along any slopes;
- Temporary stabilization of disturbed areas;
- Permanent and temporary seeding, as portions of the landfill cells are completed;
- Riprap outlet protection to be placed at all outfalls, including discharge points;
- Check dams and forebays to minimize velocities; and
- Detention basins.

The contractor shall maintain the riprap outlet protection measures and aprons at all times throughout the construction process.

#### 1.5 Management of Non-Stormwater Discharge

The following are allowable sources of non-stormwater discharges that may be associated with construction activity at the site:

- Waters used to wash vehicles where detergents are not used;

- Water used to control dust in accordance with Section 3.2.2 of the Construction General Permit;
- Uncontaminated ground water or spring water; and
- Uncontaminated excavation dewatering.

## 1.6 Post-Construction Water Quality Measures

The Post-Construction water quality measures will consist of the following:

1. Permanent grassing; and
2. Dry detention basins.

## 1.7 Buffer Zone Management

As shown on the Erosion Control Plan (Sheet C-5.0 - C-5.4 of the Construction Plans), the majority of the site provides at least a one-hundred (100) linear foot (LF) undisturbed buffer, however, double row silt fence with mulch (a minimum 3 linear feet of spacing between rows) is provided along the area adjacent to the existing wetlands and Pickens Creek. These boundaries are to be flagged and remain undisturbed during the construction of the proposed improvements. The double row fencing and mulch will provide additional protection to the jurisdictional areas during the construction process. Slopes will also be immediately stabilized to protect the integrity of the wetlands. There is a one-hundred (100) LF property setback, a fifty (50) LF wetlands buffer, and a two-hundred (200) LF limits of waste stream buffer; these buffers are to be maintained and no waste shall be placed inside of them.

**1.8 Certification Statement**

I certify under penalty of law that this document and all attachments were prepared under my direction or supervision in accordance with a system designed to assure that qualified personnel properly gathered and evaluated the information submitted. Based on my inquiry of the person or persons who manage the system, or those persons directly responsible for gathering the information, the information submitted is, to the best of my knowledge and belief, true, accurate, and complete. I am aware that there are significant penalties for submitting false information, including the possibility of fine and imprisonment for knowing violations.

Name: Ryan T. Ohmer, P.E. Title: Project Engineer  
Signature:  Date: 9/27/19

**Exhibit A Erosion and Sediment Control Plan**

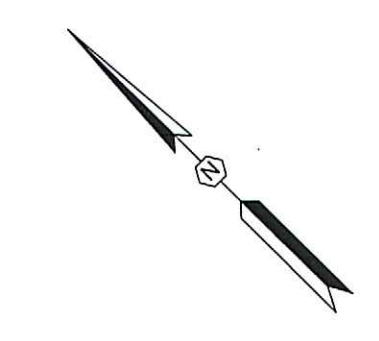
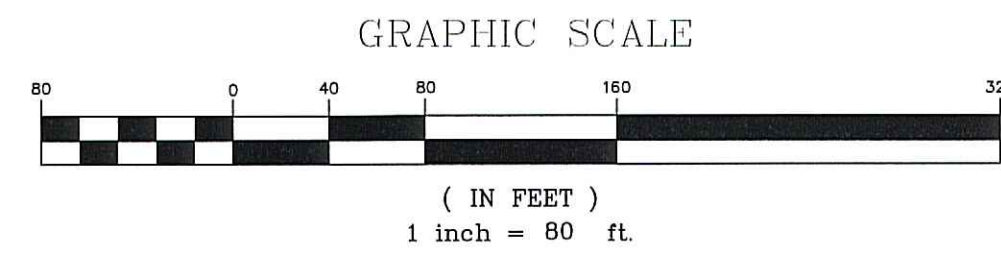

REVISION	
NO.	DATE

APPROVALS:

ENGINEER	RTO
DESIGNER	RTO
TECHNICIAN	PIJ
CHECKED BY	GTF
APPROVED	RTO

DATE: 6/27/19

REGISTERED PROFESSIONAL ENGINEER

STATE OF SOUTH CAROLINA

NO. 35683

SIGNATURE: [Signature]

**ALLIANCE CONSULTING ENGINEERS**

Alliance Consulting Engineers, Inc.  
 124 Verdae Blvd - Bonaville II, Suite 303 - Greenville, SC 29607  
 Phone: (864) 284-1740 • Fax: (864) 284-1741

PROJECT: CIVIL DESIGN PLANS FOR THE CLASS II C&D GREENPOINTE LANDFILL ALONG HAMLIN ROAD LOCATED IN ANDERSON COUNTY, SOUTH CAROLINA.

SCALE: AS SHOWN

DATE: JUNE 2019

PROJECT: CIVIL DESIGN PLANS FOR THE CLASS II C&D GREENPOINTE LANDFILL ALONG HAMLIN ROAD LOCATED IN ANDERSON COUNTY, SOUTH CAROLINA.

FILE NAME: E16227-PLANS

REFERENCE FILE: E16227-BASE

PROJECT NO.: 16227-0004

DWG NO. 01.1168-D21

SHEET C-5.0



- REFERENCES:
- REFERENCE IS MADE TO TOPOGRAPHIC SURVEY PROVIDED BY F&S SURVEYORS, ENGINEERS, & PLANNERS, INC. DATED FEBRUARY 8, 2017.
  - REFERENCE IS MADE TO LIDAR TOPOGRAPHICAL DATA PROVIDED BY ANDERSON COUNTY, SOUTH CAROLINA.
  - REFERENCE IS MADE TO A WETLAND DELINEATION PERFORMED BY F&S SURVEYORS AND ENGINEERS & PLANNERS INC. DATED JANUARY 12, 2017.
  - REFERENCE IS MADE TO A GROUNDWATER MONITORING REPORT PROVIDED BY BUNNELL-LAMMONS ENGINEERING, INC. DATED MAY 16, 2019.

THIS DOCUMENT IS THE SOLE PROPERTY OF ALLIANCE CONSULTING ENGINEERS, INC. IT IS NOT TO BE REPRODUCED, COPIED OR OTHERWISE EDITED WITHOUT THE AUTHORIZATION OF ALLIANCE CONSULTING ENGINEERS, INC. THIS DRAWING IS INTENDED SPECIFICALLY FOR THE PROJECT REFERENCED HEREIN AND IS NOT TRANSFERABLE TO ANOTHER PROJECT.

GRAPHIC SCALE  
 ( IN FEET )  
 1 inch = 60 ft.

**811**  
 Know what's below.  
 Call before you dig.

REVISION DATE	

APPROVALS

ENGINEER	RTO
DESIGNER	RTO
REGISTERED PROFESSIONAL	PRJ
CHECKED BY	GTF
APPROVED	RTO

ALLIANCE CONSULTING ENGINEERS, INC.  
 No. 00854

DATE: 9/27/19

**ALLIANCE CONSULTING ENGINEERS**  
 Alliance Consulting Engineers, Inc.  
 1234 Verdade Blvd., Boonville, IL, Suite 505 - Greenville, SC 29607  
 Phone: (864) 284-1700 Fax: (864) 284-1741

PROJECT: CIVIL DESIGN PLANS FOR THE CLASS II C&D GREENPOINTE LANDFILL ALONG HAMLIN ROAD LOCATED IN ANDERSON COUNTY, SOUTH CAROLINA

SCALE: AS SHOWN

DATE: JUNE 2019

SHEET: BASE ELEVATION EROSION AND SEDIMENT CONTROL PLAN - CELL 2

FILE NAME: E16227-PLANS  
 REFERENCE FILE: E16227-BASE  
 PROJECT NO.: 16227-0004  
 DWG NO.: 01.1168-D21

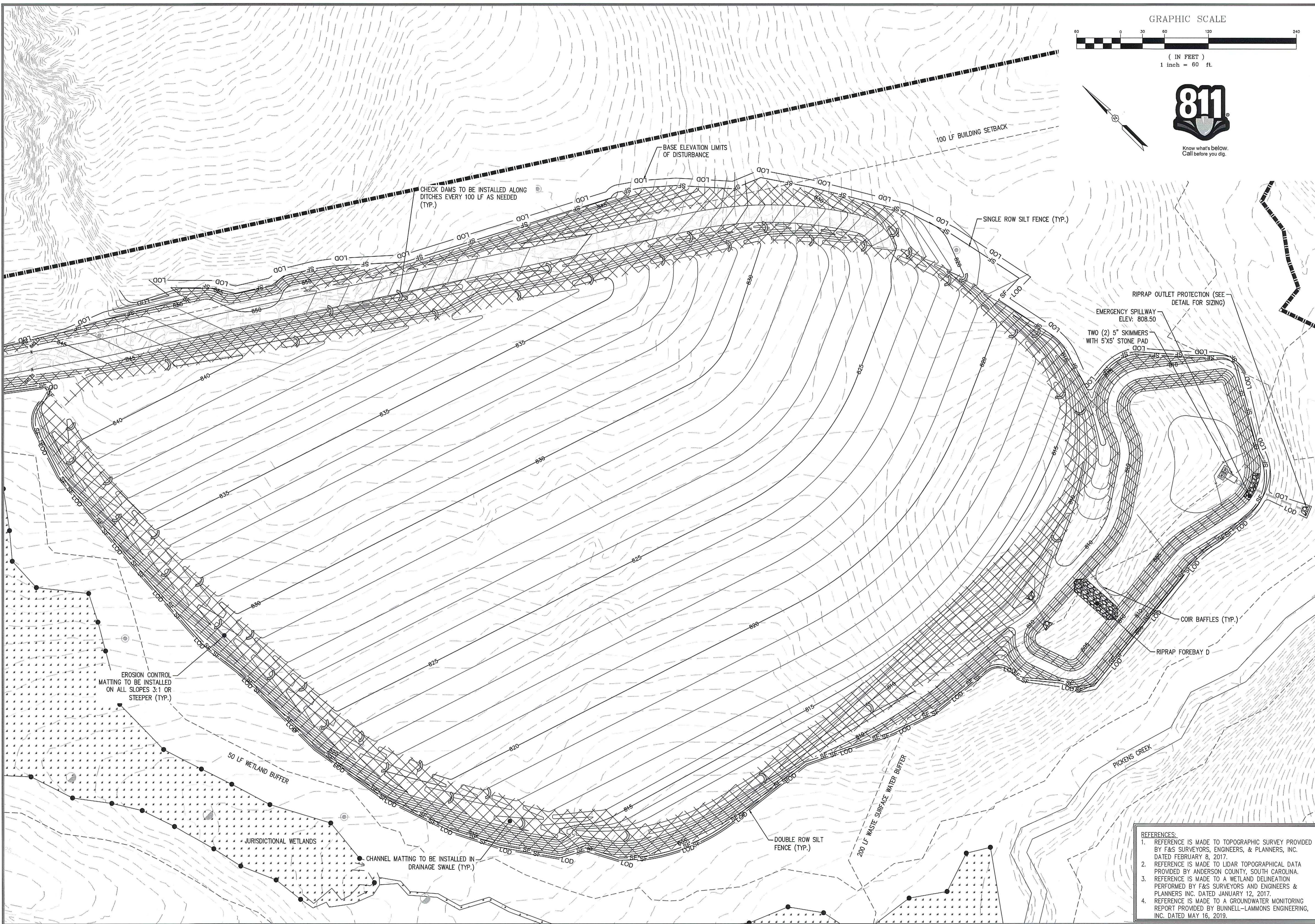

- REFERENCES:
1. REFERENCE IS MADE TO TOPOGRAPHIC SURVEY PROVIDED BY F&S SURVEYORS, ENGINEERS, & PLANNERS, INC. DATED FEBRUARY 8, 2017.
  2. REFERENCE IS MADE TO LIDAR TOPOGRAPHICAL DATA PROVIDED BY ANDERSON COUNTY, SOUTH CAROLINA. REFERENCE IS MADE TO A WETLAND DELINEATION PERFORMED BY F&S SURVEYORS AND ENGINEERS & PLANNERS INC. DATED JANUARY 12, 2017.
  3. REFERENCE IS MADE TO A GROUNDWATER MONITORING REPORT PROVIDED BY BUNNELL-LAMMONS ENGINEERING, INC. DATED MAY 16, 2019.



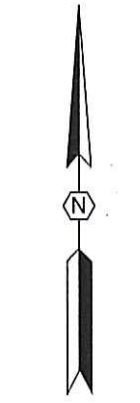
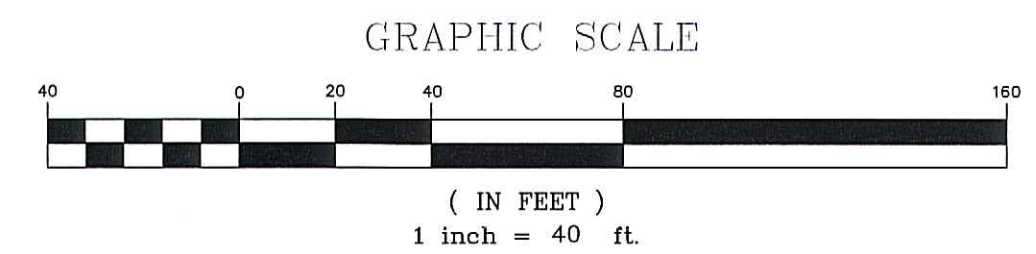

REVISION DATE	

APPROVALS

ENGINEER	DESIGNER	TECHNICIAN	CHECKED BY	APPROVED
RTO	RTO	PRJ	GTF	RTO

DATE: 9/23/19

SCOTT CARROLL, P.E.  
No. 35683

SIGNATURE: [Signature]

**ALLIANCE CONSULTING ENGINEERS, Inc.**  
Alliance Consulting Engineers, Inc.  
124 Verdie Blvd. - Bonaville II, Suite 305 - Greenville, SC 29607  
Phone (864) 294-1746 Fax (864) 284-1741

SCALE: AS SHOWN  
DATE: JUNE 2019  
SHEET

PROJECT: CIVIL DESIGN PLANS FOR THE CLASS II C&D GREENPONT LANDFILL ALONG HAMLIN ROAD LOCATED IN ANDERSON COUNTY, SOUTH CAROLINA.  
ANDERSON COUNTY SOUTH CAROLINA

FILE NAME: E16227-PLANS  
REFERENCE FILE: E16227-BASE  
PROJECT NO.: 16227-004  
DWG NO. 01.1168-D21

- REFERENCES:
1. REFERENCE IS MADE TO TOPOGRAPHIC SURVEY PROVIDED BY F&S SURVEYORS, ENGINEERS, & PLANNERS, INC. DATED FEBRUARY 8, 2017.
  2. REFERENCE IS MADE TO LIDAR TOPOGRAPHICAL DATA PROVIDED BY ANDERSON COUNTY, SOUTH CAROLINA.
  3. REFERENCE IS MADE TO A WETLAND DELINEATION PERFORMED BY F&S SURVEYORS AND ENGINEERS & PLANNERS INC. DATED JANUARY 12, 2017.
  4. REFERENCE IS MADE TO A GROUNDWATER MONITORING REPORT PROVIDED BY BUNNELL-LAMMONS ENGINEERING, INC. DATED MAY 16, 2019.

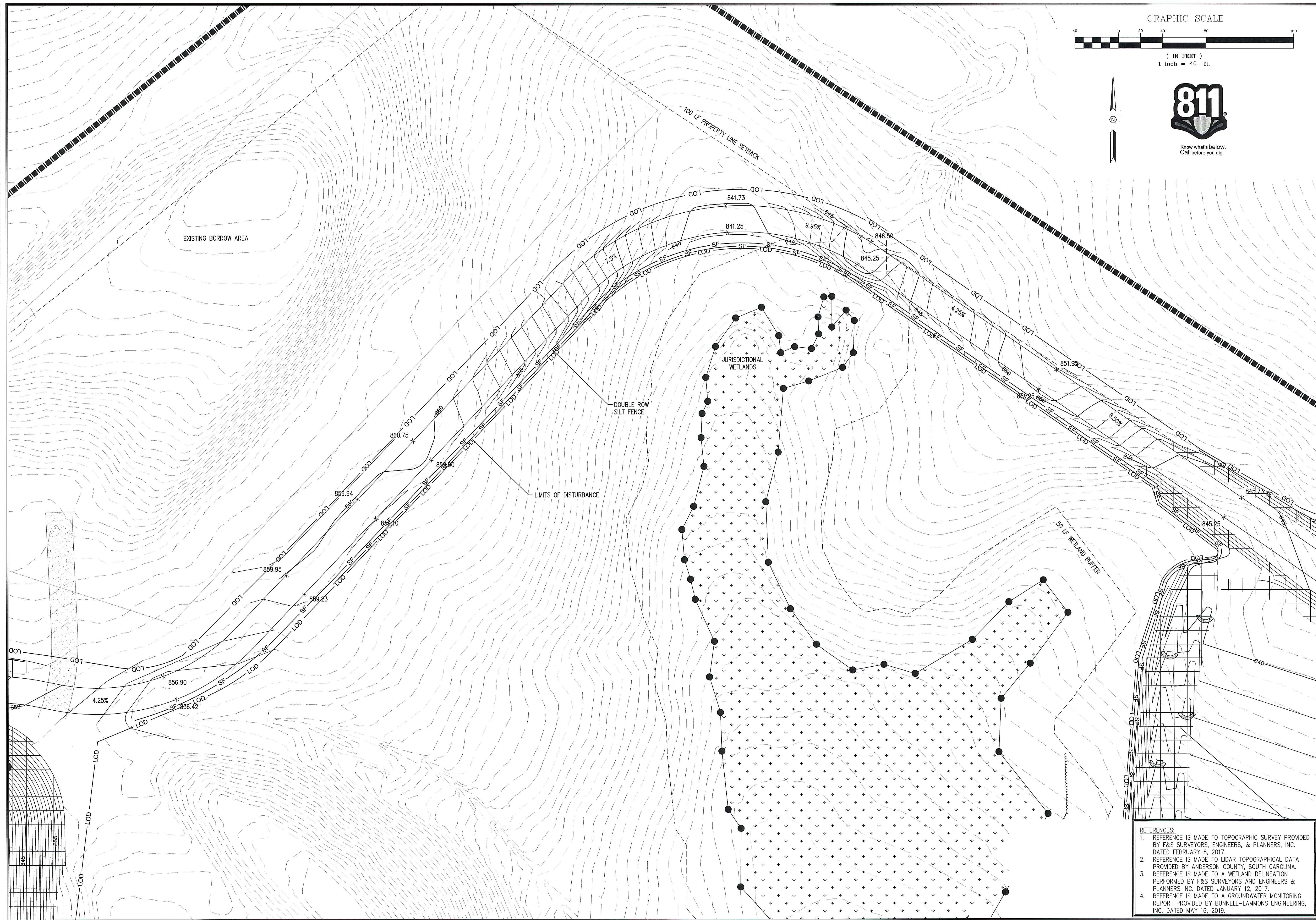

ALLIANCE CONSULTING ENGINEERS, INC. IS NOT RESPONSIBLE FOR THE ACCURACY OF THE INFORMATION PROVIDED IN THIS DRAWING. THE USER OF THIS DRAWING SHALL BE RESPONSIBLE FOR OBTAINING ALL NECESSARY PERMITS AND FOR VERIFYING THE ACCURACY OF ALL INFORMATION PROVIDED BY OTHERS.

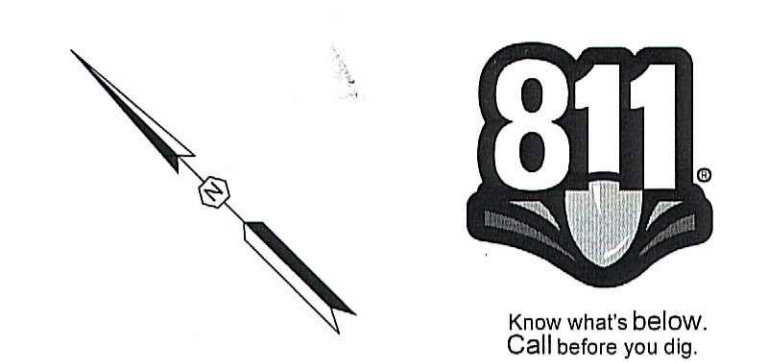
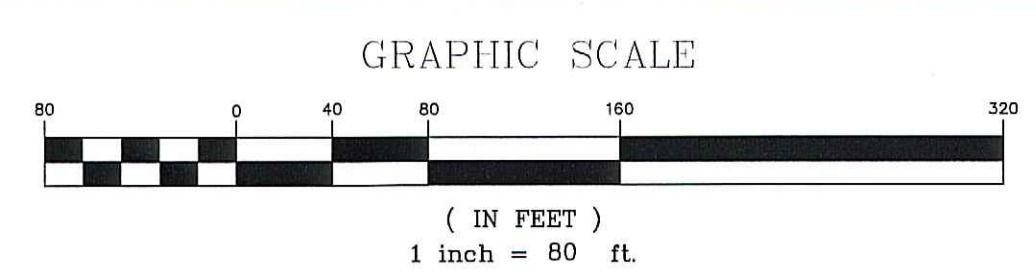
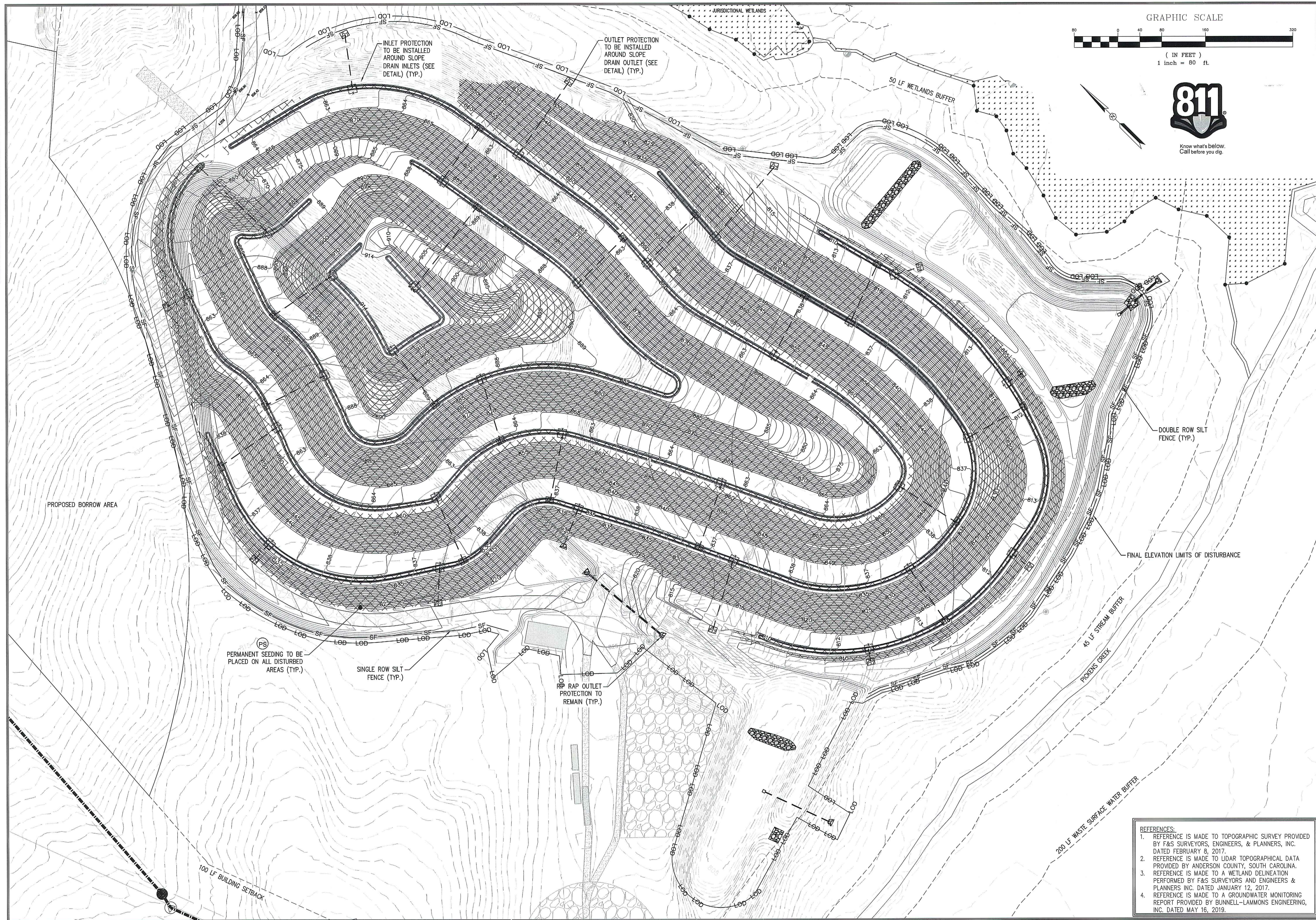

REVISION	
NO.	DATE

APPROVALS

ENGINEER	RTO
DESIGNER	RTO
TECHNICIAN	PSJ
CHECKED BY	GTF
APPROVED	RTO

DATE: 9/27/19

ALLIANCE CONSULTING ENGINEERS, INC.

Professional Engineer Seal for South Carolina, No. 35683.

SIGNATURE: [Handwritten Signature]

**ALLIANCE CONSULTING ENGINEERS**

Alliance Consulting Engineers, Inc.  
 124 Verdier Blvd. - Greenville II, Suite 305 - Greenville, SC 29607  
 Phone (864) 284-1740 • Fax (864) 284-1741

PROJECT: CIVIL DESIGN PLANS FOR THE GREENPONT LANDFILL ALONG HAMLIN ROAD LOCATED IN ANDERSON COUNTY, SOUTH CAROLINA.

SCALE: AS SHOWN

DATE: JUNE 2019

SHEET: C-53

- REFERENCES:
- REFERENCE IS MADE TO TOPOGRAPHIC SURVEY PROVIDED BY F&S SURVEYORS, ENGINEERS, & PLANNERS, INC. DATED FEBRUARY 8, 2017.
  - REFERENCE IS MADE TO LIDAR TOPOGRAPHICAL DATA PROVIDED BY ANDERSON COUNTY, SOUTH CAROLINA.
  - REFERENCE IS MADE TO A WETLAND DELINEATION PERFORMED BY F&S SURVEYORS AND ENGINEERS & PLANNERS INC. DATED JANUARY 12, 2017.
  - REFERENCE IS MADE TO A GROUNDWATER MONITORING REPORT PROVIDED BY BUNNELL-LAMMONS ENGINEERING, INC. DATED MAY 16, 2019.

FILE NAME:	E16227-PLANS
REFERENCE FILE:	E16227-BASE
PROJECT NO.:	16227-0004
DWG NO.:	01.1168-D21

THIS DOCUMENT IS THE SOLE PROPERTY OF ALLIANCE CONSULTING ENGINEERS, INC. IT IS NOT TO BE REPRODUCED, COPIED OR OTHERWISE LOANED WITH OUT THE APPROVATION OF ALLIANCE CONSULTING ENGINEERS, INC. THIS DRAWING IS INTENDED SPECIFICALLY FOR THE PROJECT REFERENCED HEREIN AND IS NOT TRANSPARENT TO ANY OTHER PROJECT.

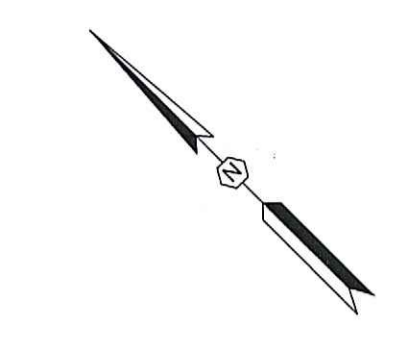
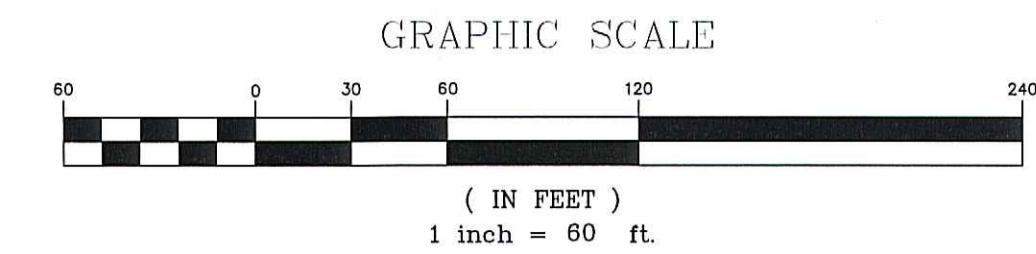

REVISION DATE	

APPROVALS

ENGINEER	RTO
DESIGNER	RTO
TECHNICIAN	PR
CHECKED BY	GTP
APPROVED	RTO

ALLIANCE CONSULTING ENGINEERS, INC. No. 002854

DATE: 9/27/19

REGISTERED PROFESSIONAL ENGINEER

STATE OF SOUTH CAROLINA

No. 35683

DATE: 9/27/19

**ALLIANCE CONSULTING ENGINEERS**

Alliance Consulting Engineers, Inc.  
 Alliance Consulting Engineers, Inc. Greenville, SC 29607  
 124 Verdrie Blvd. - Bonaventure II, Suite 305 - Greenville, SC 29607  
 Phone (864) 284-1740 • Fax (864) 284-1741

PROJECT: CIVIL DESIGN PLANS FOR THE CLASS II C&D GREENPOINTE LANDFILL ALONG HAMLIN ROAD LOCATED IN ANDERSON COUNTY, SOUTH CAROLINA

SCALE: AS SHOWN

DATE: JUNE 2019

FILE NAME: E16227-PLANS

REFERENCE FILE: E16227-BASE

PROJECT NO: 16227-0004

SHEET C-5.4

DWG NO. 01,1168-D21

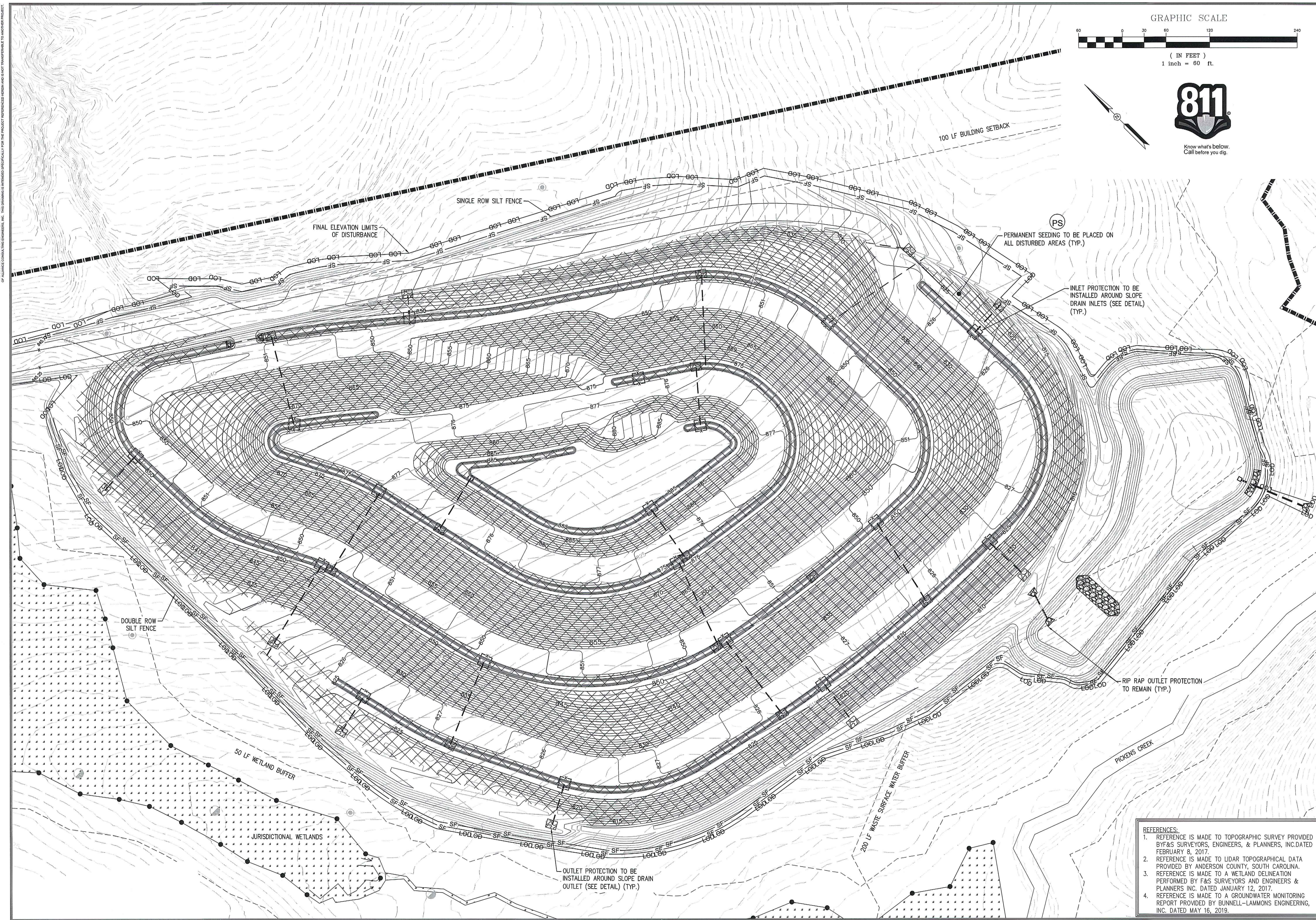

- REFERENCES:
1. REFERENCE IS MADE TO TOPOGRAPHIC SURVEY PROVIDED BY F&S SURVEYORS, ENGINEERS, & PLANNERS, INC. DATED FEBRUARY 8, 2017.
  2. REFERENCE IS MADE TO LIDAR TOPOGRAPHICAL DATA PROVIDED BY ANDERSON COUNTY, SOUTH CAROLINA.
  3. REFERENCE IS MADE TO A WETLAND DELINEATION PERFORMED BY F&S SURVEYORS AND ENGINEERS & PLANNERS INC. DATED JANUARY 12, 2017.
  4. REFERENCE IS MADE TO A GROUNDWATER MONITORING REPORT PROVIDED BY BUNNELL-LAMMONS ENGINEERING, INC. DATED MAY 16, 2019.

## 2.0 Site Features and Sensitive Areas

### 2.1 Sources of Pollution

Pollutants that result from clearing, grading, and excavation have the potential to be present in stormwater runoff are listed in **Table 3** below. This table includes information regarding material type, chemical and physical description, and the specific regulated stormwater pollutants associated with each material.

**Table 3 - Potential Construction Site Stormwater Pollutants**

<i>Trade Name Material</i>	<i>Chemical/Physical Description<sup>(1)</sup></i>	<i>Stormwater Pollutants<sup>(1)</sup></i>
<i>Pesticides (insecticides, fungicides, herbicides, rodenticides)</i>	<i>Various colored to colorless liquid, powder, pellets, or grains</i>	<i>Chlorinated hydrocarbons, organophosphates, carbamates, arsenic</i>
<i>Fertilizer</i>	<i>Liquid or solid grains</i>	<i>Nitrogen, phosphorous</i>
<i>Cleaning solvents</i>	<i>Colorless, blue, or yellow-green liquid</i>	<i>Perchloroethylene, methylene chloride, trichloroethylene, petroleum distillates</i>
<i>Asphalt</i>	<i>Black solid</i>	<i>Oil, petroleum distillates</i>
<i>Concrete</i>	<i>White solid</i>	<i>Limestone, sand</i>
<i>Wastewater from construction equipment washing</i>	<i>Water</i>	<i>Soil, oil &amp; grease, solids</i>
<i>Hydraulic oil/fluids</i>	<i>Brown oily petroleum hydrocarbon</i>	<i>Mineral oil</i>
<i>Gasoline</i>	<i>Colorless, pale brown or pink petroleum hydrocarbon</i>	<i>Benzene, ethyl benzene, toluene, xylene, MTBE</i>
<i>Diesel Fuel</i>	<i>Clear, blue-green to yellow liquid</i>	<i>Petroleum distillate, oil &amp; grease, naphthalene, xylenes</i>

<i>Kerosene</i>	<i>Pale yellow liquid petroleum hydrocarbon</i>	<i>Coal oil, petroleum distillates</i>
<i>Antifreeze/coolant</i>	<i>Clear green/yellow liquid</i>	<i>Ethylene glycol, propylene glycol, heavy metals (copper, lead, zinc)</i>
<i>Erosion</i>	<i>Solid Particles</i>	<i>Soil, Sediment</i>

<sup>(1)</sup> Data obtained from MSDSs when available

## 2.2 Surface Waters

A jurisdictional creek (Pickens Creek), is present along the southern portion of the site. This wetland area should not be negatively impacted from construction of this proposed development due to the proposed Best Management Practices (detention basin, rip rap outlet protection at basin outfall within the site, and the double row silt fencing) and ongoing monitoring and measures provided as part of the landfill permit.

The proposed stormwater attenuation by the new detention basins was designed to meet the requirements of SCDHEC. This additional flow should not create additional adverse impacts to the existing downstream conditions.

### 3.0 Compliance Requirements

#### 3.1 SWPPP Availability

A copy of the On-Site Stormwater Pollution Prevention Plan (OS-SWPPP) will be retained at the construction site or a nearby location easily accessible during normal business hours, from the date of commencement of construction activities to the date the final stabilization is reached. Contractors who have day-to-day operational control over OS-SWPPP implementation will have a copy of this SWPPP available at a central location within the construction site for use by all those identified as having responsibilities under the OS-SWPPP. If it is not practical to have the OS-SWPPP at the site, the permittee and or operator will, upon request make the OS-SWPPP available by the end of normal business hours, or by the following business day under extenuating circumstances. The OS-SWPPP will be made available upon request and at the time of a construction site inspection by SCDHEC, local government officials, and operator of a Municipal Separate Storm Sewer System (MS4) receiving discharges from the construction site to the requestor.

#### 3.2 Pre-Construction Conference

A pre-construction conference will be held at the construction site. Each contractor, subcontractor, blanket utility provider, etc., who will work at the site will attend this conference in person. The primary purpose of this conference is for:

- I. The preparer of the SWPPP and someone with a registration equivalent to that of the preparer of the SWPPP; and/or
- II. The person with operational control of the plans and specifications or their duly authorized representative

To review and explain the OS-SWPPP so that all are aware of the requirements before they start performing construction-related activities that may affect the implementation of the approved OS-SWPPP.

#### 3.3 Inspection Requirements

Visual inspections of cleared and graded areas of the construction site will be performed once every seven (7) calendar days for active landfills. The inspection will be conducted by the SWPPP coordinator or his designated stormwater team members. The inspection will verify that the structural BMPs described in Section 1 of this SWPPP are in good condition and are

minimizing erosion. The inspection will also verify that the procedures used to prevent stormwater contamination from construction materials and petroleum products are effective. The following inspection and maintenance practices will be used to maintain erosion and sediment controls:

- Built up sediment will be removed from silt fencing when it has reached one-third the height of the fence.
- Silt fences and inlet protections (if applicable) will be inspected for depth of sediment, for tears, to determine if the fabric is securely attached to the fence posts, and to ensure that the fence posts are firmly in the ground.
- Temporary and permanent seeding will be inspected for bare spots, washouts, and healthy growth.
- The stabilized construction entrance will be inspected for sediment tracked on the road, for clean gravel, and to ensure that all traffic use the stabilized entrance when leaving the site.
- Built up sediment will be removed from rip rap outlet protection.
- Sediment forebays will be inspected and cleaned out as needed.
- The detention basin will be inspected for sediment accumulation after each rain event, and skimmer observed to ensure it is functioning properly.

### 3.4 Maintenance Policies

All maintenance to sediment and erosion control devices shall be in accordance with the Construction Details. The contractor shall maintain the existing BMPs at all times.

Permanent maintenance of the detention basins will include the following:

- Periodic grass cutting,
- Trash and sediment build up within basin,
- Trash and debris removal from Outlet Control Structure,
- Outlet Control Structure orifices and weir cleaning, a
- Outlet pipes to be cleaned, inspected and repaired,
- Rip Rap outlet protection to be maintained,
- Tree growth to not be allowed along the detention basin berms, and
- Erosion on side slopes.

### 3.5 Record Keeping

The maintenance inspection report will be made after each inspection. A copy of the report form to be completed by the SWPPP coordinator will be provided in the OS-SWPPP. In the event that a spill was to take place on the site, the SWPPP Coordinator will complete a spill report as outlined in the OS-SWPPP. Completed forms will be maintained on-site during the entire

construction project. Following construction, the completed forms will be retained at the General Contractor's office for a minimum of one (1) year.

If construction activities or design modifications are made to the site plan, which could impact stormwater, this SWPPP will be amended appropriately. The amended SWPPP will have a description of the new activities that contribute to the increased pollutant loading and the planned source control activities.

### **3.6 Final Stabilization**

Final stabilization will occur as each stage of the landfill cells are brought to final grade and when all land-disturbing activities at the construction site have been completed and all areas not covered by permanent structures, either (1) have a uniform vegetative cover with a density of 75 percent of the natural background vegetative cover, or (2) equivalent permanent stabilization measures have been implemented to provide effective cover for exposed portions of the construction site not stabilized with vegetation.



**APPENDIX A      Site Maps**

# GREENPOINTE CLASS TWO CONSTRUCTION AND DEMOLITION DEBRIS LANDFILL EXPANSION IN ANDERSON COUNTY, SOUTH CAROLINA VICINITY MAP

+/- 212 Acres

Wasteco, Inc.

**ALLIANCE**  
CONSULTING ENGINEERS

PREPARED BY:  
ALLIANCE CONSULTING ENGINEERS, INC.  
JANUARY 18, 2018

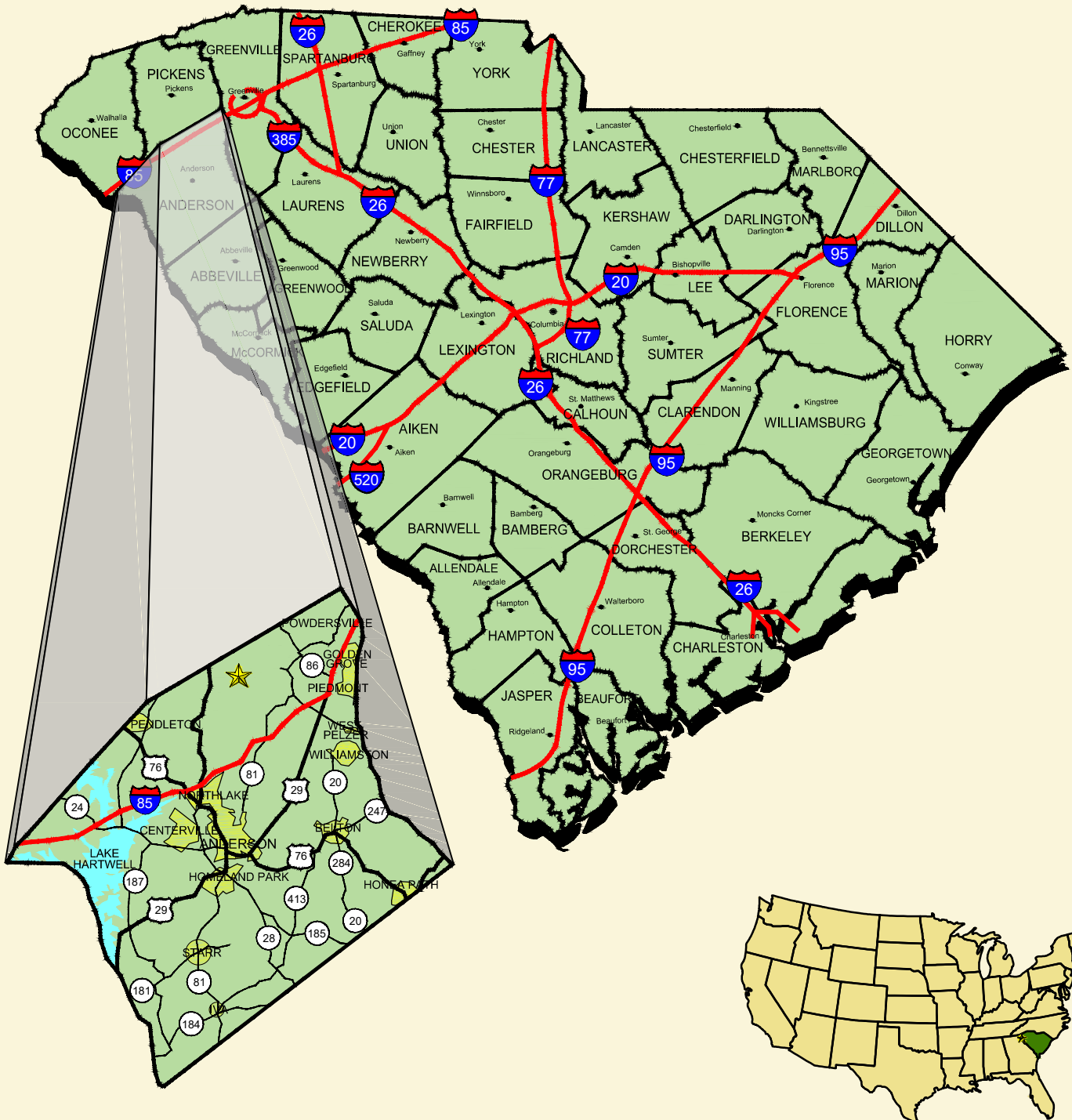



**GREENPOINTE CLASS TWO CONSTRUCTION AND  
DEMOLITION DEBRIS LANDFILL EXPANSION IN  
ANDERSON COUNTY, SOUTH CAROLINA  
AERIAL MAP**

PICKENS COUNTY  
ANDERSON COUNTY

**Wasteco, Inc.**

**+/- 212 Acres**

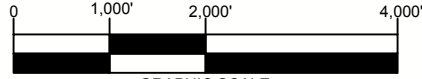

GRAPHIC SCALE  
JANUARY 18, 2018

PREPARED BY:  
ALLIANCE CONSULTING ENGINEERS, INC.  
INFORMATION FROM:  
USDA NRCS GEOSPATIAL DATA GATEWAY  
ANDERSON COUNTY, SOUTH CAROLINA  
DATED: 2011

**SITE**

HENDRICKS ROAD

HANN ROAD

88



**GREENPOINTE CLASS TWO CONSTRUCTION AND  
DEMOLITION DEBRIS LANDFILL EXPANSION IN  
ANDERSON COUNTY, SOUTH CAROLINA  
TOPOGRAPHIC MAP**

**Wasteco, Inc.**

**+/- 212 Acres**

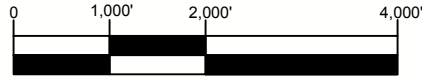

GRAPHIC SCALE  
CONTOUR INTERVAL 3 FEET  
JANUARY 18, 2018



PREPARED BY:  
ALLIANCE CONSULTING ENGINEERS, INC.  
INFORMATION FROM:  
ANDERSON COUNTY, SOUTH CAROLINA  
USGS DATA  
DATED 2001

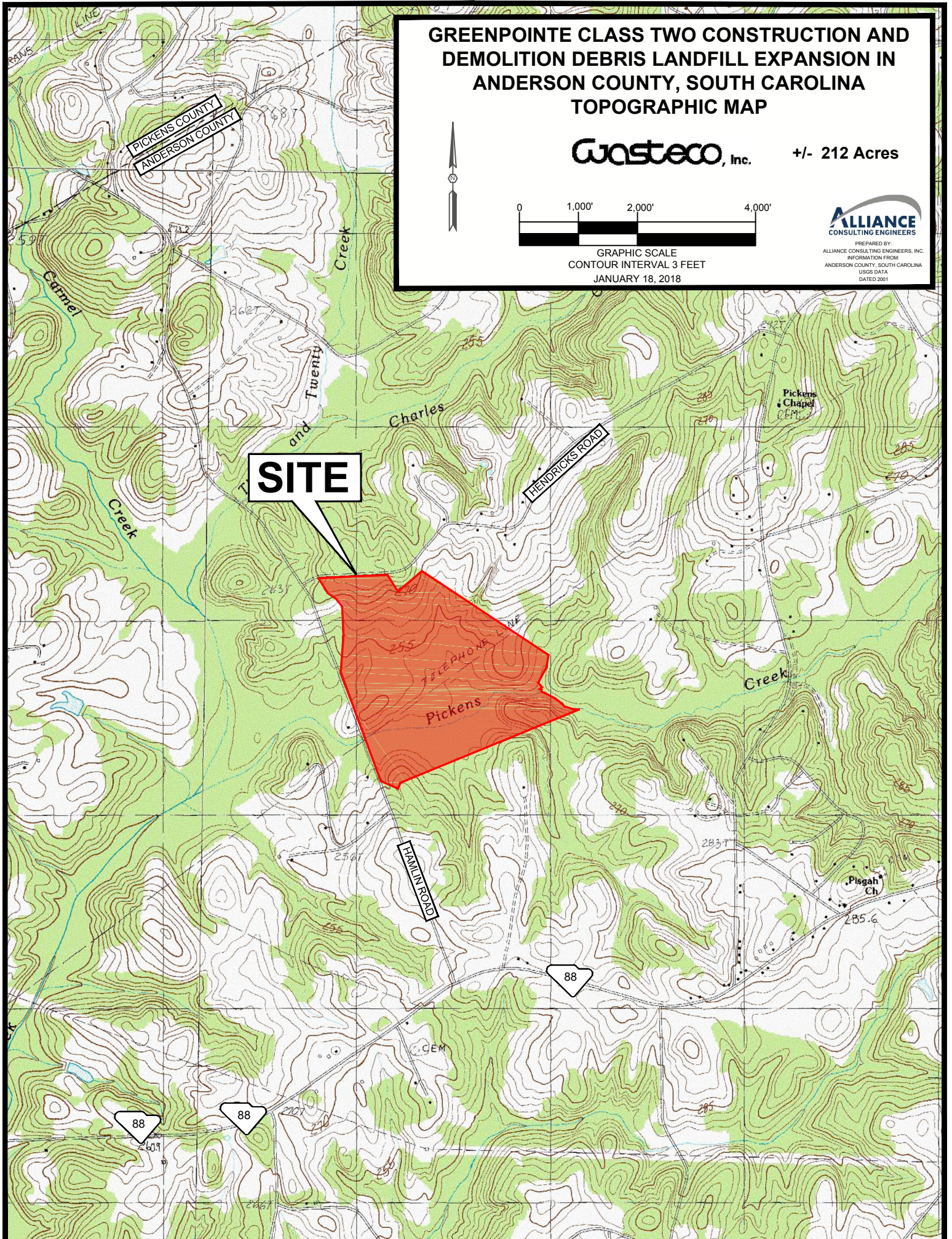

# GREENPOINTE CLASS TWO CONSTRUCTION AND DEMOLITION DEBRIS LANDFILL EXPANSION IN ANDERSON COUNTY, SOUTH CAROLINA SOILS MAP

**Wasteco, Inc.**

+/- 212 Acres

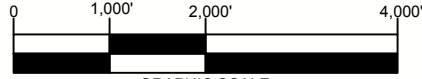

GRAPHIC SCALE  
JANUARY 18, 2018



PREPARED BY:  
ALLIANCE CONSULTING ENGINEERS, INC.  
INFORMATION FROM:  
ANDERSON COUNTY, SOUTH CAROLINA  
USDA NRCS SOIL DATAMART  
DATED 2009

**SITE**

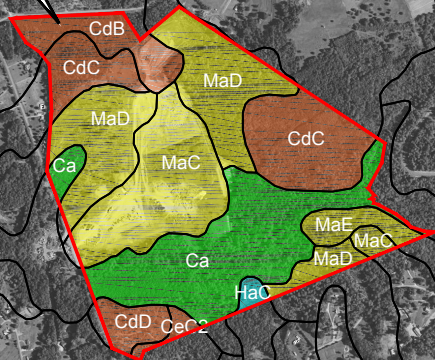

HENDRICKS ROAD

HAMLIN ROAD

88

**LEGEND**

- Cartecay ( Ca)
- Cecil ( CdB, CdC, CdD, CeC2)
- Hiwassee ( HaC)
- Madison ( MaC, MaD, MaE)

**HSG**

- B/D
- B
- B
- B

# GREENPOINTE CLASS TWO CONSTRUCTION AND DEMOLITION DEBRIS LANDFILL EXPANSION IN ANDERSON COUNTY, SOUTH CAROLINA FEMA FLOOD MAP

**Wasteco, Inc.**

**+/- 212 Acres**

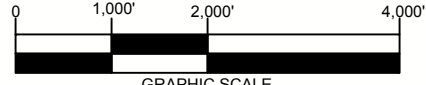

GRAPHIC SCALE  
JANUARY 18, 2018

**ALLIANCE**  
CONSULTING ENGINEERS  
PREPARED BY:  
ALLIANCE CONSULTING ENGINEERS, INC.  
INFORMATION FROM:  
FEMA FLOOD MAP CATALOG  
PANEL NO. 4507C040E, 4507C010E,  
4507C010E, 4507C290D, 4507C031D,  
4507C041D  
DATED 2011

**SITE**

ZONE X

HENDRICKS RD

Anderson County  
Unincorporated Areas  
450013

**LEGEND**

- ZONE A/AE - Areas of 100-Year Flood
- ZONE X - Areas of Minimal Flooding

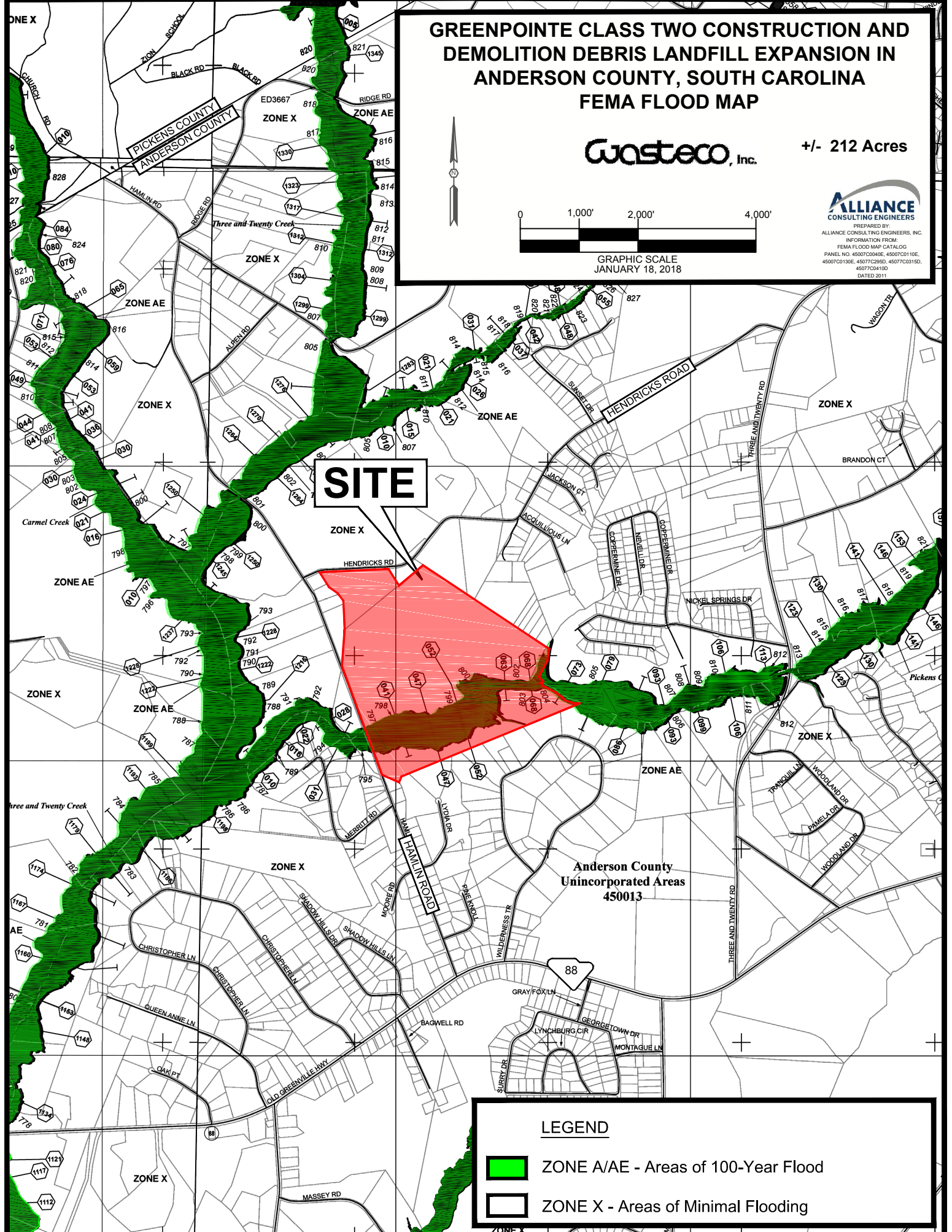

**GREENPOINTE CLASS TWO CONSTRUCTION AND DEMOLITION DEBRIS LANDFILL EXPANSION IN ANDERSON COUNTY, SOUTH CAROLINA  
NATIONAL WETLAND INVENTORY (NWI) MAP**

**Wasteco, Inc.**

**+/- 212 Acres**

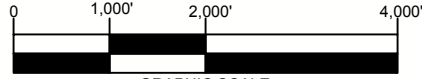

GRAPHIC SCALE  
JANUARY 18, 2018



PREPARED BY:  
ALLIANCE CONSULTING ENGINEERS, INC.  
INFORMATION FROM:  
WETLAND ONLINE MAPPER  
CREDIT: US FISH AND WILDLIFE SERVICE

**SITE**

WETLANDS LEGEND	
	Freshwater Emergent
	Freshwater Forested/Shrub
	Estuarine and Marine Deepwater
	Estuarine and Marine
	Freshwater Pond
	Lake
	Riverine
	Other

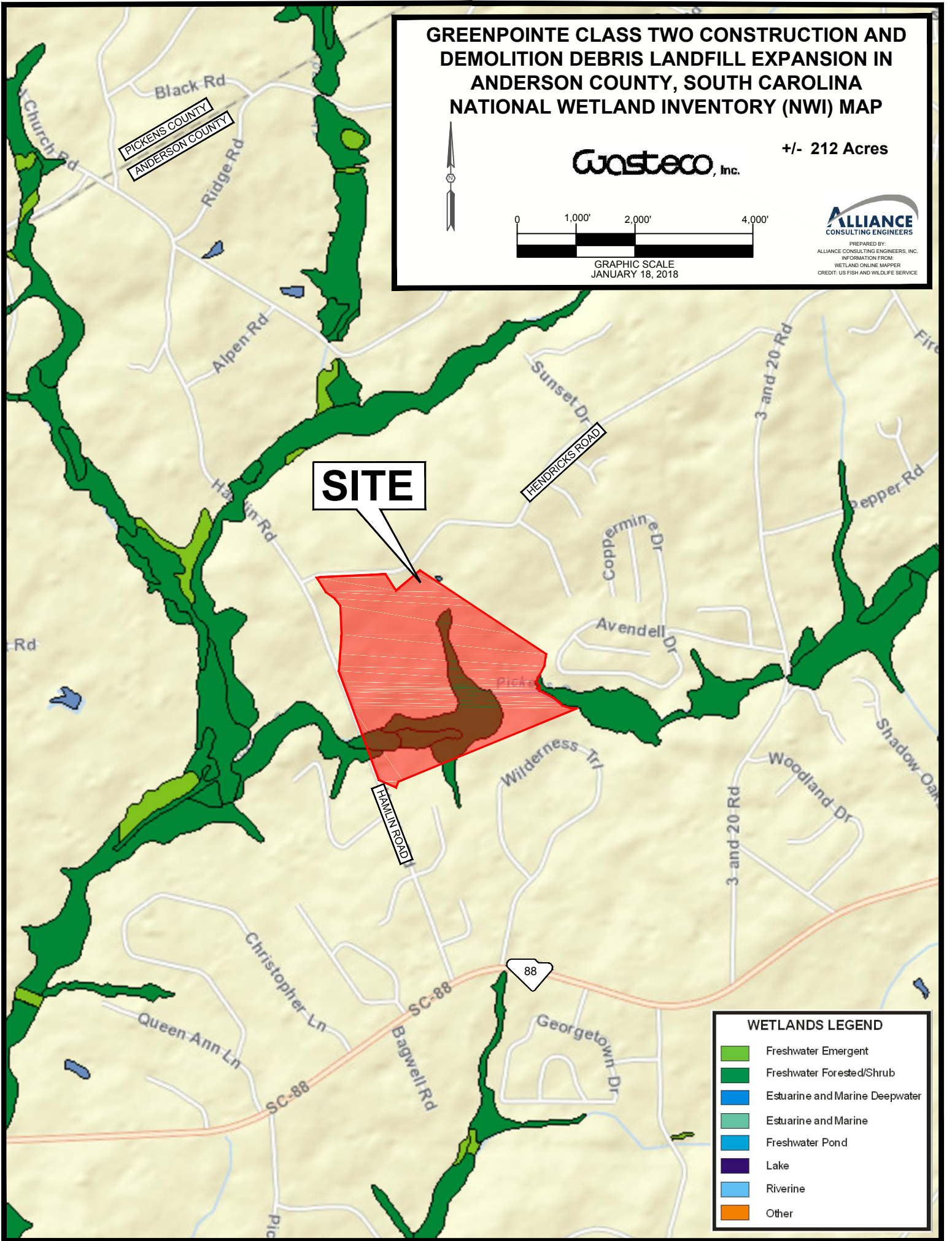



**APPENDIX B      Pre and Post Development Maps**

- Cell 1 – Pre-Development Map (Previously Permitted)**
- Cell 2 – Pre-Development Map**
- Cell 1 – Post-Development Map**
- Cell 2 – Post-Development Map**

# PRE-DEVELOPMENT WATERSHED DRAINAGE MAP-CELL 1 (PREVIOUSLY PERMITTED LF2-100)

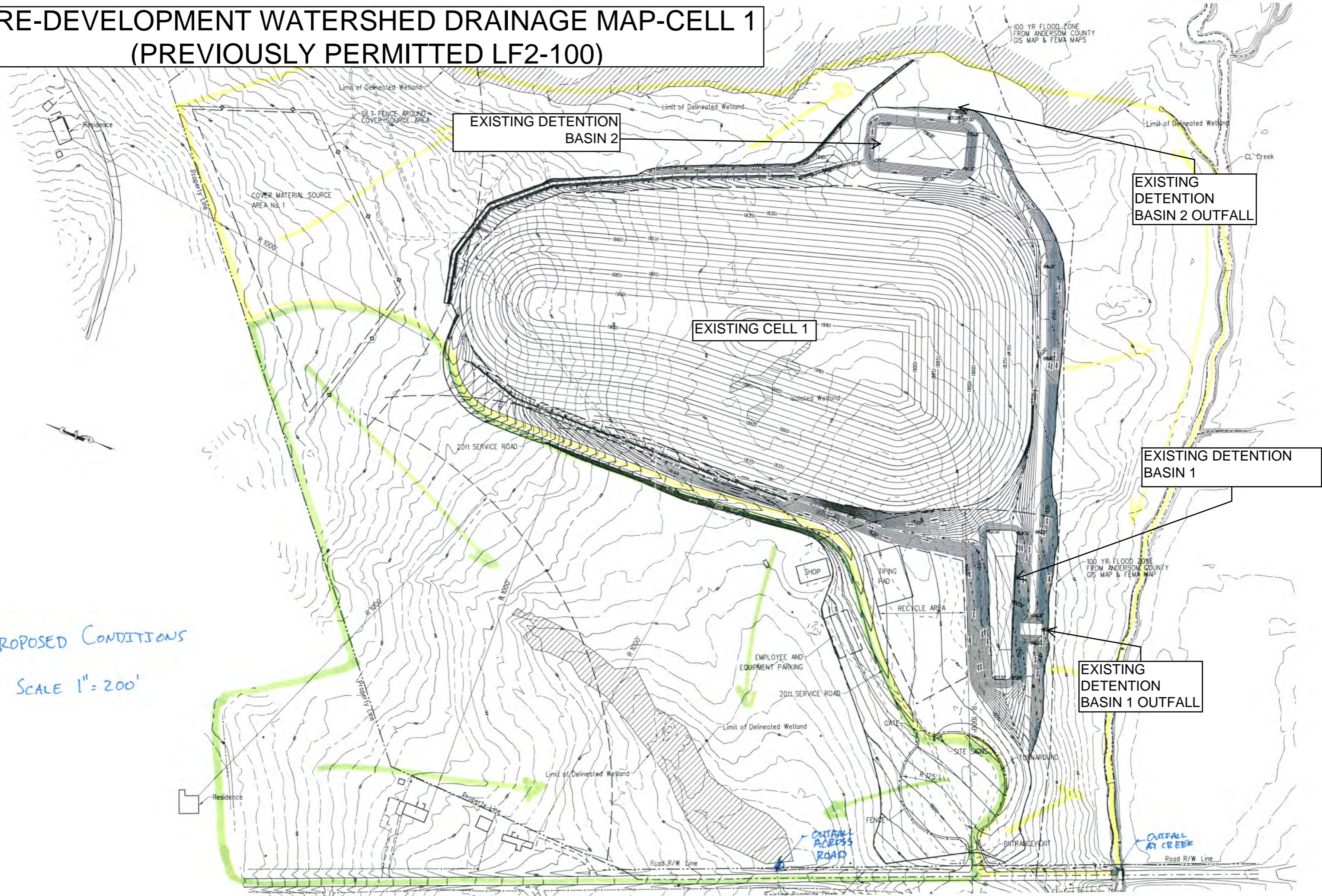

PROPOSED CONDITIONS  
SCALE 1" = 200'

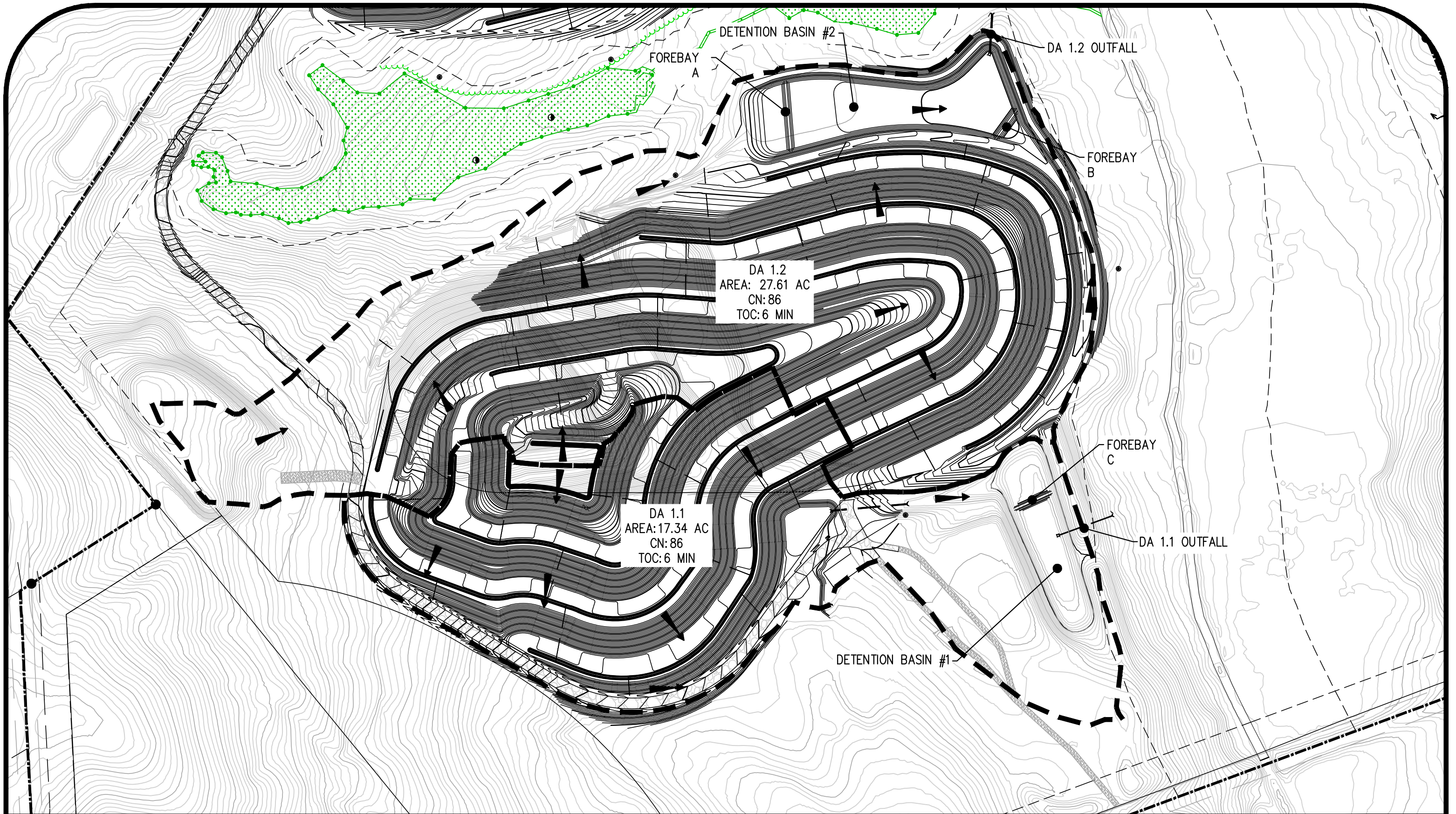

Documents prepared or furnished by Alliance Consulting Engineers, Inc. are instruments of service, and Alliance Consulting Engineers, Inc. retains an ownership and property interest (including the copyright and the right of reuse) in such documents, whether or not the project is completed.

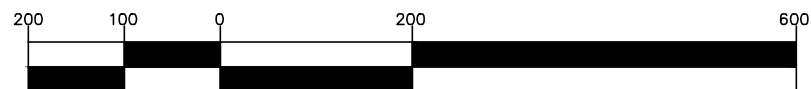

( IN FEET )

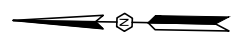

Project No.: 16227-0004  
March, 2018

## Post-Development Watershed Map - Cell 1 for Project Greenpointe Landfill in Anderson County, South Carolina



Prepared by Alliance Consulting Engineers, Inc.  
124 Verdae Blvd, Greenville, SC 29607-3843  
864-284-1740  
www.alliancece.com

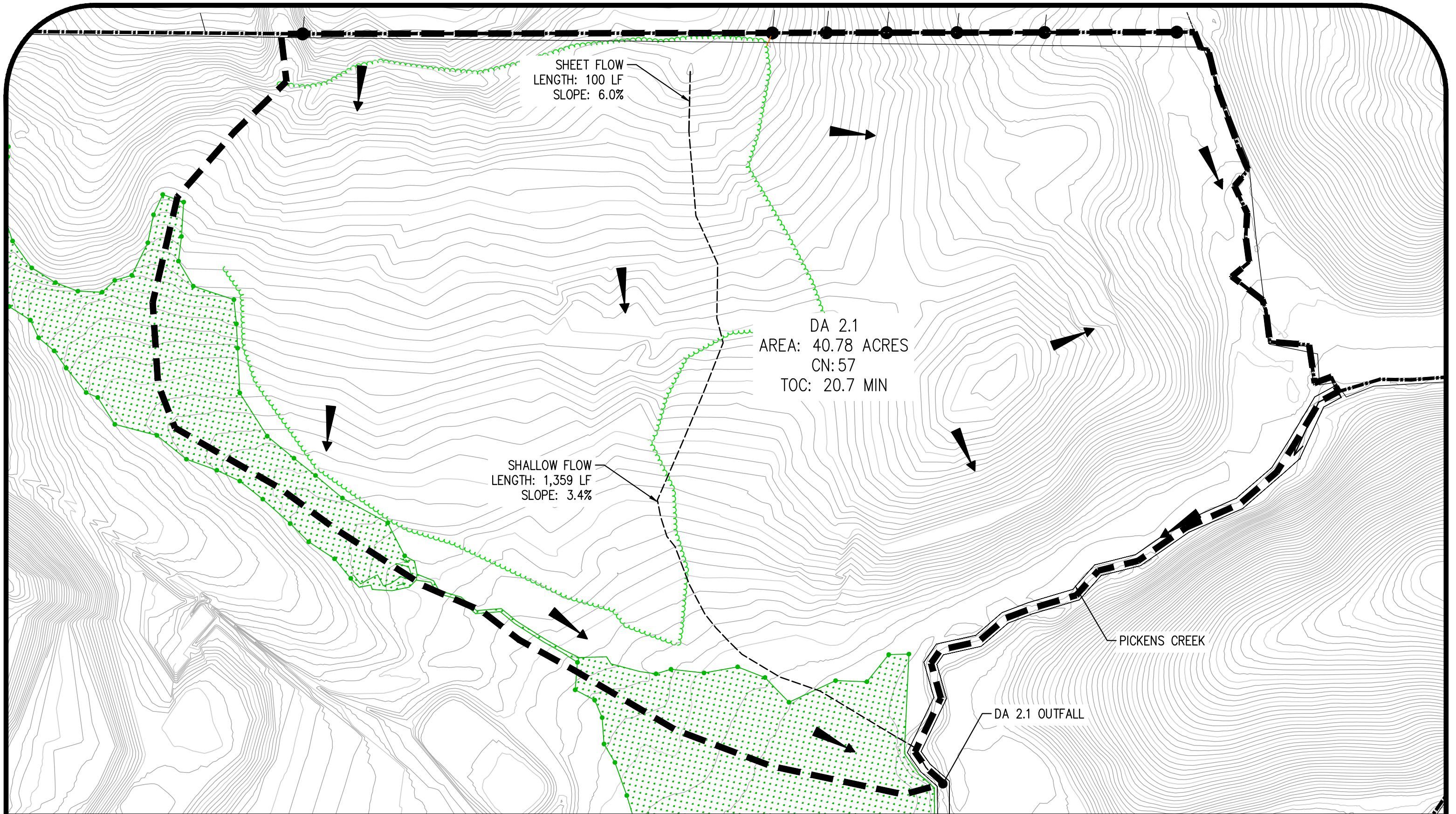

Documents prepared or furnished by Alliance Consulting Engineers, Inc. are instruments of service, and Alliance Consulting Engineers, Inc. retains an ownership and property interest (including the copyright and the right of reuse) in such documents, whether or not the project is completed.

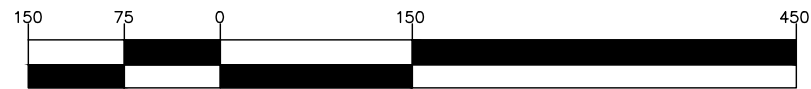

( IN FEET )

Project No.: 16227-0004  
March, 2018

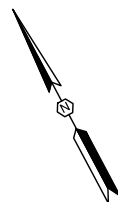

## Pre-Development Watershed Map - Cell 2 for Project Greenpointe Landfill in Anderson County, South Carolina



Prepared by Alliance Consulting Engineers, Inc.  
124 Verdae Blvd, Greenville, SC 29607-3843  
864-284-1740  
www.allianceCE.com

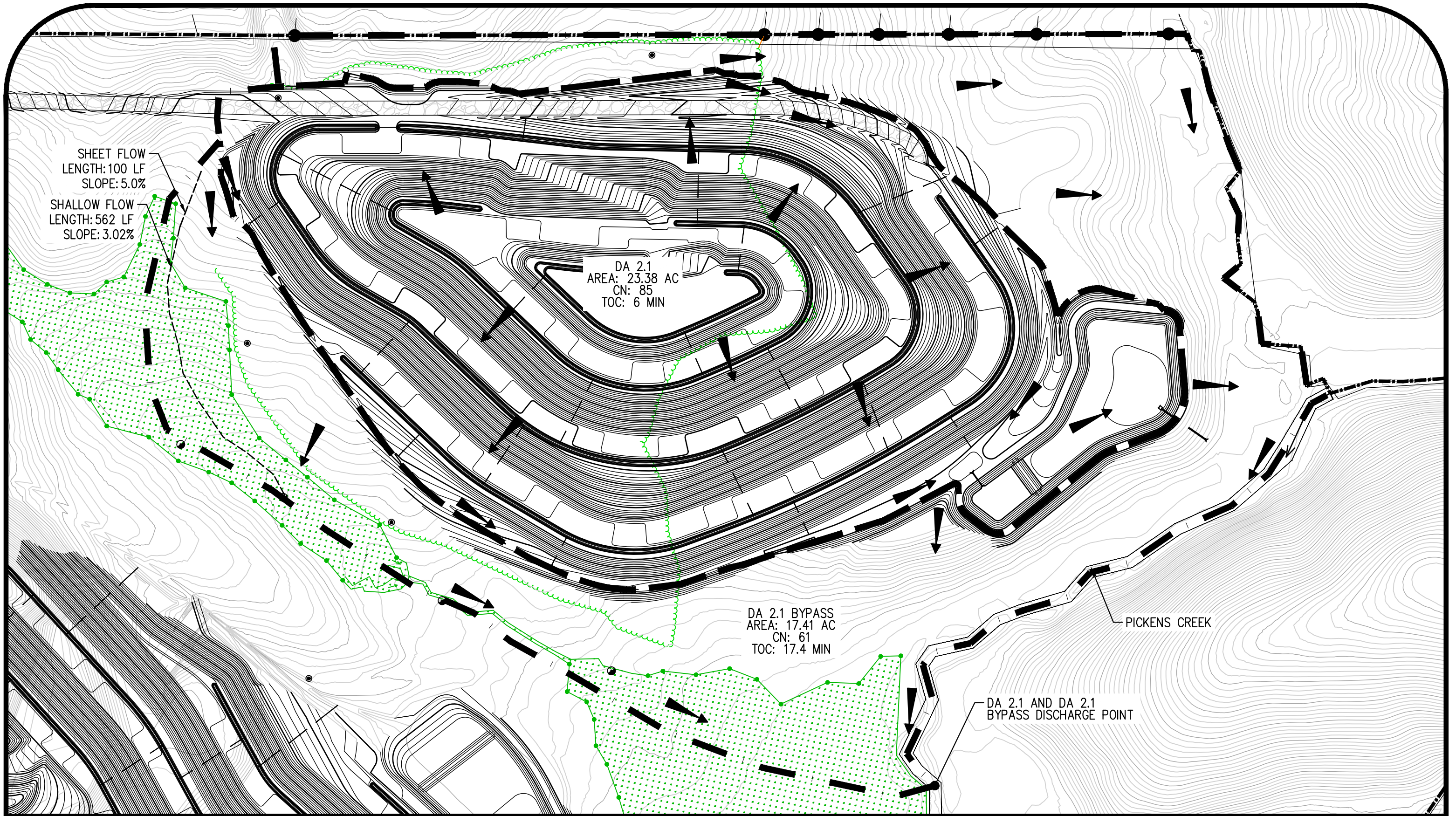

Documents prepared or furnished by Alliance Consulting Engineers, Inc. are instruments of service, and Alliance Consulting Engineers, Inc. retains an ownership and property interest (including the copyright and the right of reuse) in such documents, whether or not the project is completed.

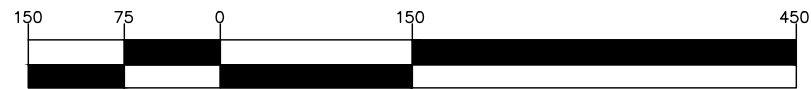

( IN FEET )

Project No.: 16227-0004  
March, 2018

## Post-Development Watershed Map - Cell 2 for Project Greenpointe Landfill in Anderson County, South Carolina



Prepared by Alliance Consulting Engineers, Inc.  
124 Verdae Blvd, Greenville, SC 29607-3843  
864-284-1740  
www.alliancece.com

**APPENDIX C      Pre-Development – Previously Permitted Calculations and HydroCAD**

**-Cell 1 - Previously Permitted Calculations**

**-Cell 2 -HydroCAD**

BLWM # 21126

164.6

1 of 2

CONSTRUCTION, DEMOLITION, AND LAND  
CLEARING DEBRIS LANDFILL PLAN  
FOR THE GREENPOINTE  
C & D LANDFILL SITE  
ANDERSON COUNTY, SOUTH CAROLINA

APPROVED BY  
SOUTH CAROLINA DEPARTMENT OF HEALTH  
AND ENVIRONMENTAL CONTROL  
Bureau of Land & Waste Management  
BY *Kent M. Chesser*  
TITLE Division Director  
DATE ISSUED 7-10-2008  
PERMIT NO. LF2-001

RECEIVED

MAY 19 2008

DIVISION OF MINING &  
SOLID WASTE MANAGEMENT  
BLWM

CONSTRUCTION, DEMOLITION, AND LAND  
CLEARING DEBRIS LANDFILL PLAN  
FOR THE GREENPOINTE  
C & D LANDFILL SITE  
ANDERSON COUNTY, SOUTH CAROLINA

RECEIVED

MAY 19 2006

DIVISION OF MINING &  
SOLID WASTE MANAGEMENT  
BLWM

SEPTEMBER, 2005

REVISED NOVEMBER, 2005

REVISED OCTOBER 2007

REVISED MAY 2008

DAVIS & FLOYD, INC. JOB NUMBER 11967.00

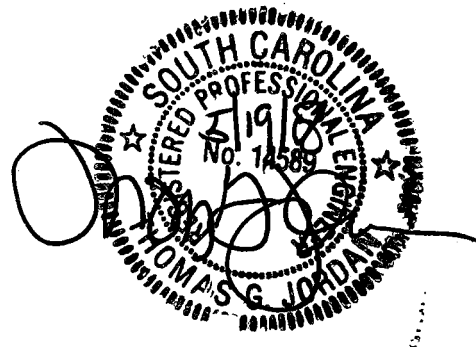
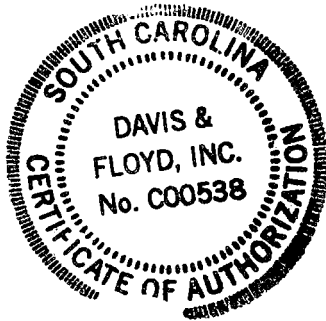

PREPARED BY  
DAVIS & FLOYD, INC.  
ENVIRONMENTAL DIVISION  
GREENWOOD, SOUTH CAROLINA



## TABLE OF CONTENTS

	<u>PAGE</u>
1.0 GENERAL INFORMATION	1.1
2.0 CONSTRUCTION, DEMOLITION, AND LAND CLEARING DEBRIS LANDFILL DESIGN	2.1
2.1 Hydrogeologic Characteristics	2.1
2.2 Availability of Adequate Soil Cover	2.2
2.3 Land Use	2.3
3.0 METHOD OF OPERATION	3.1
3.1 Landfill Operations	3.1
4.0 REQUIRED EQUIPMENT	4.1
5.0 DRAINAGE AND SEDIMENT CONTROL	5.1
6.0 RECORDKEEPING	6.1
7.0 PERMIT REVIEW	7.1
8.0 CLOSURE PROCEDURES AND POST CLOSURE CARE	8.1

### APPENDICES

APPENDIX 1	PERMIT APPLICATION
APPENDIX 2	LAND USE MAP
APPENDIX 3	SEDIMENT CONTROL DESIGN
APPENDIX 4	MISCELLANEOUS
APPENDIX 5	CELL SEQUENCING PLAN
APPENDIX 6	SETTLEMENT CALCULATION REPORT

**APPENDIX 3**  
**SEDIMENT CONTROL DESIGN**

Area Identification			Predeveloped 10 year Peak Flow (cfs)			Postdeveloped 10 year Peak Flow (cfs)
Total Runoff			190.06			124.31

Area Identification			Predeveloped 10 year Peak Flow (cfs)			Postdeveloped 10 year Peak Flow (cfs)
Across Road			81.53			71.91
At Creek			108.1			52.4

EXISTING CONDITIONS  
SCALE 1" = 200'

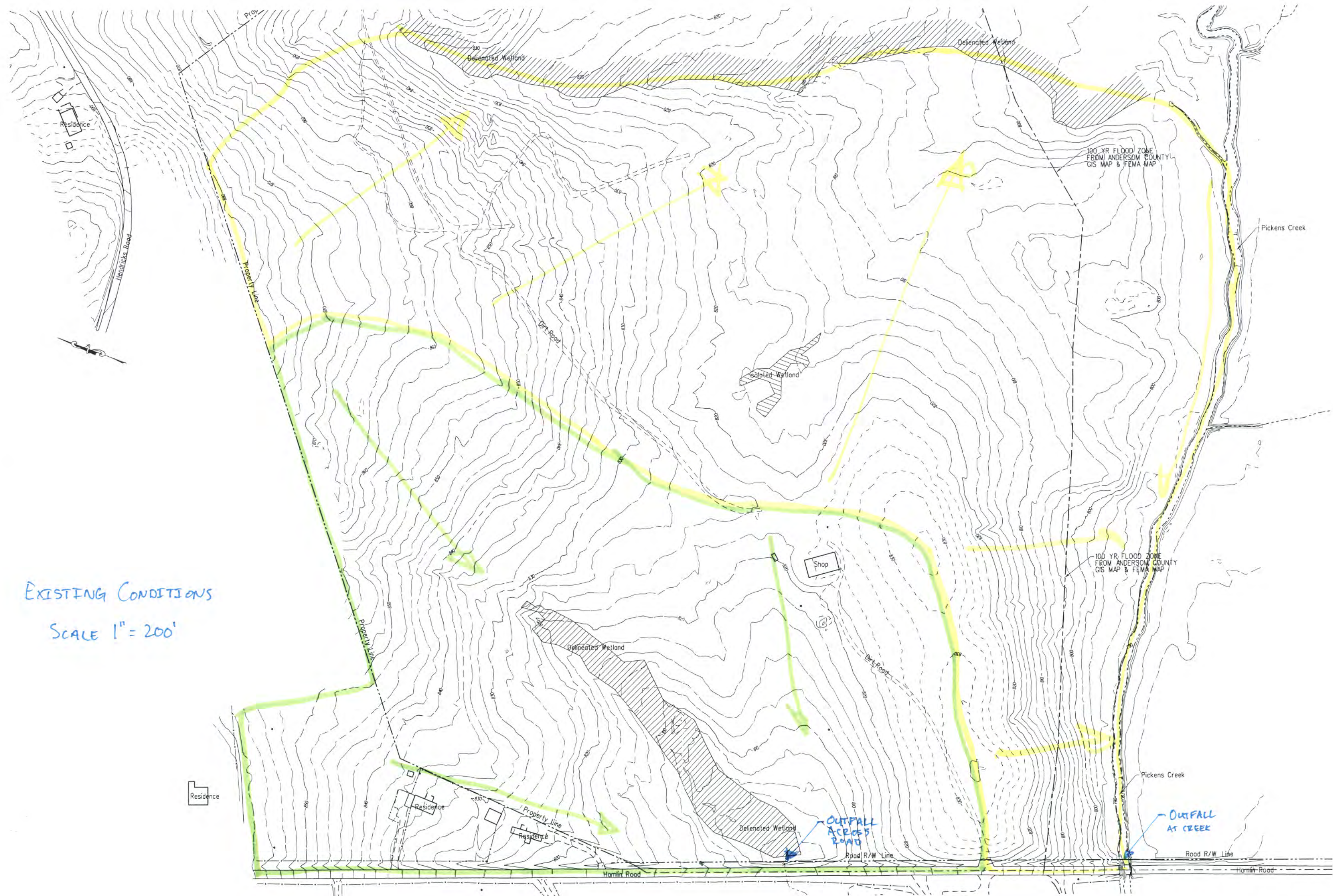

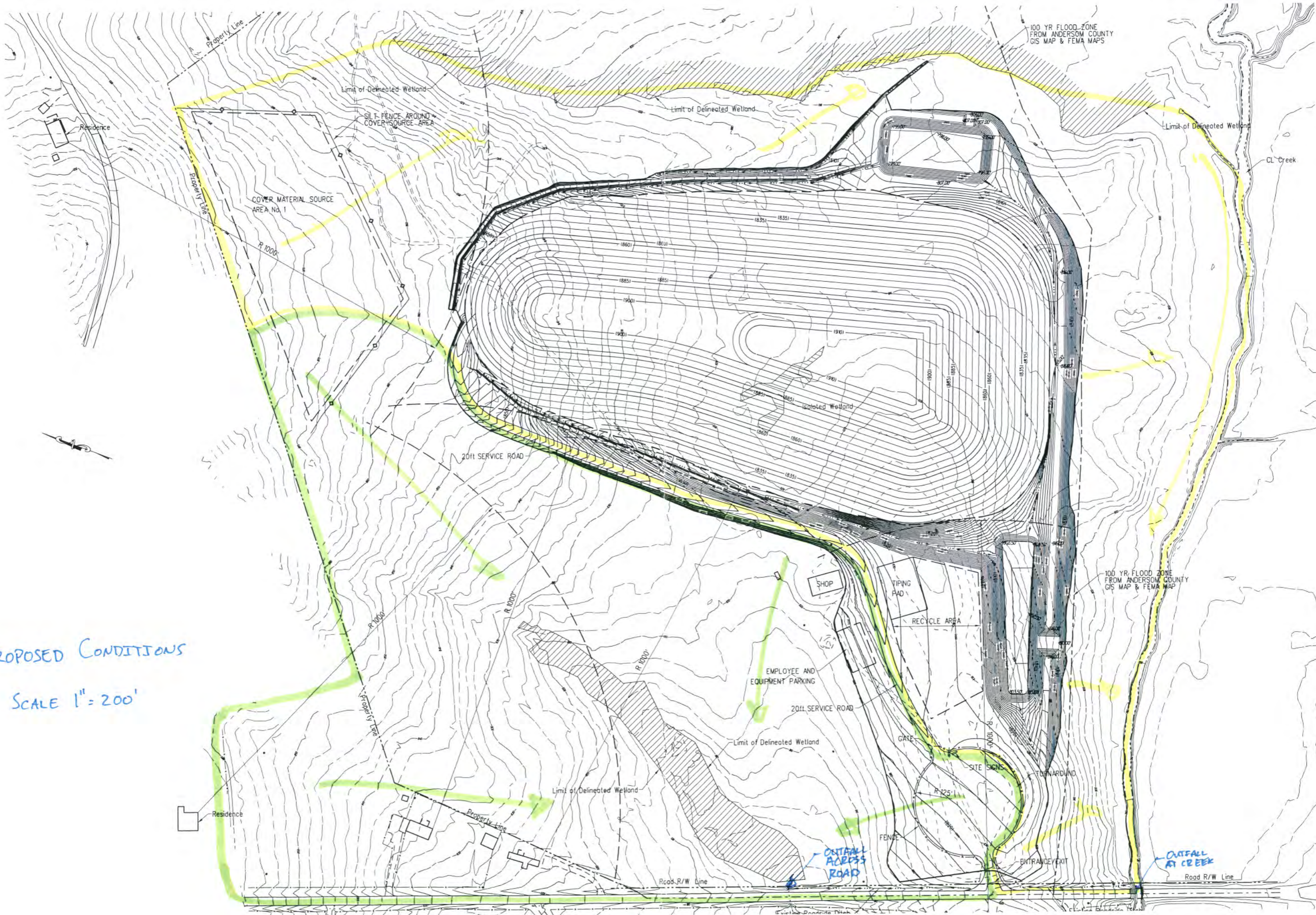

PROPOSED CONDITIONS  
 SCALE 1" = 200'

OUTFALL ACCESS ROAD

OUTFALL AT CREEK

# Outfall At Creek

Davis & Floyd, Inc.  
1319 Hwy 72 221 E.  
Greenwood, SC 29649

Phone: 864-229-5211

***General Information***

***Storm Information:***

Storm Type:	NRCS Type II
Design Storm:	10 yr - 24 hr
Rainfall Depth:	5.500 inches

***Particle Size Distribution:***

Size (mm)	Madison
1.4000	100.000%
1.0000	84.600%
0.0630	49.300%
0.0440	42.600%
0.0380	42.600%
0.0040	8.800%
0.0030	5.800%
0.0010	0.000%

### Structure Networking:

Type	Stru #	(flows into)	Stru #	Musk. K (hrs)	Musk. X	Description
Null	#1	==>	End	0.000	0.000	

#1  
Null



***Structure Summary:***

	Immediate Contributing Area (ac)	Total Contributing Area (ac)	Peak Discharge (cfs)	Total Runoff Volume (ac-ft)	Sediment (tons)	Peak Sediment Conc. (mg/l)	Peak Settleable Conc. (ml/l)	24VW (ml/l)
#1	58.650	58.650	108.10	12.35	88.6	9,574	5.16	2.84

***Particle Size Distribution(s) at Each Structure***

***Structure #1:***

Size (mm)	In/Out
1.4000	100.000%
1.0000	100.000%
0.0630	70.972%
0.0440	61.327%
0.0380	61.327%
0.0040	12.668%
0.0030	8.350%
0.0010	0.000%

---

***Structure Detail:***

*Structure #1 (Null)*

**Subwatershed Hydrology Detail:**

Stru #	SWS #	SWS Area (ac)	Time of Conc (hrs)	Musk K (hrs)	Musk X	Curve Number	UHS	Peak Discharge (cfs)	Runoff Volume (ac-ft)
#1	1	24.850	0.252	0.252	0.355	77.000	M	49.26	5.064
	2	33.800	0.326	0.326	0.348	79.000	M	66.03	7.287
<b>Σ</b>		<b>58.650</b>						<b>108.10</b>	<b>12.351</b>

**Subwatershed Sedimentology Detail:**

Stru #	SWS #	Soil K	L (ft)	S (%)	C	P	PS #	Sediment (tons)	Peak Sediment Conc. (mg/l)	Peak Settleable Conc. (ml/l)	24WW (ml/l)
#1	1	0.240	200.00	1.50	0.1700	1.0000	1	23.1	6,171	3.48	1.89
	2	0.240	300.00	5.00	0.0830	1.0000	1	72.9	13,375	7.44	4.08
<b>Σ</b>								<b>88.6</b>	<b>9,574</b>	<b>5.16</b>	<b>2.84</b>

**Subwatershed Time of Concentration Details:**

Stru #	SWS #	Land Flow Condition	Slope (%)	Vert. Dist. (ft)	Horiz. Dist. (ft)	Velocity (fps)	Time (hrs)
#1	1	8. Large gullies, diversions, and low flowing streams	2.00	38.00	1,900.00	4.240	0.124
		9. Small streams flowing bankfull	0.21	4.00	1,900.23	4.120	0.128
<b>#1</b>	<b>1</b>	<b>Time of Concentration:</b>					<b>0.252</b>
#1	2	3. Short grass pasture	6.55	36.00	550.00	2.040	0.074
		8. Large gullies, diversions, and low flowing streams	2.00	38.00	1,900.00	4.240	0.124
		9. Small streams flowing bankfull	0.21	4.00	1,900.00	4.120	0.128
<b>#1</b>	<b>2</b>	<b>Time of Concentration:</b>					<b>0.326</b>

**Subwatershed Muskingum Routing Details:**

Stru #	SWS #	Land Flow Condition	Slope (%)	Vert. Dist. (ft)	Horiz. Dist. (ft)	Velocity (fps)	Time (hrs)
#1	1	8. Large gullies, diversions, and low flowing streams	2.00	38.00	1,900.00	4.240	0.124
		9. Small streams flowing bankfull	0.21	4.00	1,900.00	4.120	0.128
<b>#1</b>	<b>1</b>	<b>Muskingum K:</b>					<b>0.252</b>
#1	2	3. Short grass pasture	6.55	36.00	550.00	2.040	0.074

# SEDCAD 4 for Windows

Copyright 1998-2002 Pamela I. Schwab

Stru #	SWS #	Land Flow Condition	Slope (%)	Vert. Dist. (ft)	Horiz. Dist. (ft)	Velocity (fps)	Time (hrs)
		8. Large gullies, diversions, and low flowing streams	2.00	38.00	1,900.00	4.240	0.124
		9. Small streams flowing bankfull	0.21	4.00	1,900.00	4.120	0.128
<b>#1</b>	<b>2</b>	<b>Muskingum K:</b>					<b>0.326</b>

# **Outfall Across Road**

Davis & Floyd, Inc.  
1319 Hwy 72 221 E.  
Greenwood, SC 29649

Phone: 864-229-5211

## ***General Information***

### ***Storm Information:***

Storm Type:	NRCS Type II
Design Storm:	10 yr - 24 hr
Rainfall Depth:	5.500 inches

### ***Particle Size Distribution:***

Size (mm)	Madison
1.4000	100.000%
1.0000	84.600%
0.0630	49.300%
0.0440	42.600%
0.0380	42.600%
0.0040	8.800%
0.0030	5.800%
0.0010	0.000%

**Structure Networking:**

Type	Stru #	(flows into)	Stru #	Musk. K (hrs)	Musk. X	Description
Null	#1	==>	End	0.000	0.000	

#1
Null



***Structure Summary:***

	Immediate Contributing Area (ac)	Total Contributing Area (ac)	Peak Discharge (cfs)	Total Runoff Volume (ac-ft)	Sediment (tons)	Peak Sediment Conc. (mg/l)	Peak Settleable Conc. (ml/l)	24VW (ml/l)
#1	38.126	38.126	81.53	8.73	77.8	12,714	6.95	3.57

***Particle Size Distribution(s) at Each Structure******Structure #1:***

Size (mm)	In/Out
1.4000	100.000%
1.0000	99.650%
0.0630	68.654%
0.0440	59.324%
0.0380	59.324%
0.0040	12.255%
0.0030	8.077%
0.0010	0.000%

---

***Structure Detail:***

*Structure #1 (Null)*

***Subwatershed Hydrology Detail:***

Stru #	SWS #	SWS Area (ac)	Time of Conc (hrs)	Musk K (hrs)	Musk X	Curve Number	UHS	Peak Discharge (cfs)	Runoff Volume (ac-ft)
#1	1	1.760	0.040	0.040	0.369	98.000	M	7.39	0.771
	2	36.366	0.172	0.172	0.325	79.000	M	83.16	7.957
<b>Σ</b>		<b>38.126</b>						<b>81.53</b>	<b>8.728</b>

***Subwatershed Sedimentology Detail:***

Stru #	SWS #	Soil K	L (ft)	S (%)	C	P	PS #	Sediment (tons)	Peak Sediment Conc. (mg/l)	Peak Settleable Conc (ml/l)	24VW (ml/l)
#1	1	0.240	200.00	1.50	0.1700	1.0000	1	2.5	4,358	2.67	1.44
	2	0.240	300.00	5.00	0.0830	1.0000	1	86.5	14,743	8.48	4.58
<b>Σ</b>								<b>77.8</b>	<b>12,714</b>	<b>6.95</b>	<b>3.57</b>

***Subwatershed Time of Concentration Details:***

Stru #	SWS #	Land Flow Condition	Slope (%)	Vert. Dist. (ft)	Horiz. Dist. (ft)	Velocity (fps)	Time (hrs)
#1	1	8. Large gullies, diversions, and low flowing streams	2.57	18.00	700.00	4.810	0.040
<b>#1</b>	<b>1</b>	<b>Time of Concentration:</b>					<b>0.040</b>
#1	2	3. Short grass pasture	5.56	50.00	900.00	1.880	0.132
		8. Large gullies, diversions, and low flowing streams	2.57	18.00	700.00	4.810	0.040
<b>#1</b>	<b>2</b>	<b>Time of Concentration:</b>					<b>0.172</b>

***Subwatershed Muskingum Routing Details:***

Stru #	SWS #	Land Flow Condition	Slope (%)	Vert. Dist. (ft)	Horiz. Dist. (ft)	Velocity (fps)	Time (hrs)
#1	1	8. Large gullies, diversions, and low flowing streams	2.57	18.00	700.00	4.810	0.040
<b>#1</b>	<b>1</b>	<b>Muskingum K:</b>					<b>0.040</b>
#1	2	8. Large gullies, diversions, and low flowing streams	2.57	18.00	700.00	4.810	0.040
		3. Short grass pasture	5.56	50.00	900.00	1.880	0.132
<b>#1</b>	<b>2</b>	<b>Muskingum K:</b>					<b>0.172</b>

# **Diversion Ditch 25-yr**

Davis & Floyd, Inc.  
1319 Hwy 72 221 E.  
Greenwood, SC 29649

Phone: 864-229-5211

---

***General Information***

***Storm Information:***

Storm Type:	NRCS Type II
Design Storm:	25 yr - 24 hr
Rainfall Depth:	6.600 inches

***Particle Size Distribution:***

Size (mm)	Madison
1.4000	100.000%
1.0000	84.600%
0.0630	49.300%
0.0440	42.600%
0.0380	42.600%
0.0040	8.800%
0.0030	5.800%
0.0010	0.000%

**Structure Networking:**

Type	Stru #	(flows into)	Stru #	Musk. K (hrs)	Musk. X	Description
Channel	#1	==>	End	0.000	0.000	

#1  
Chan1

***Structure Summary:***

	Immediate Contributing Area (ac)	Total Contributing Area (ac)	Peak Discharge (cfs)	Total Runoff Volume (ac-ft)	Sediment (tons)	Peak Sediment Conc. (mg/l)	Peak Settleable Conc. (ml/l)	24VW (ml/l)
#1	1.485	1.485	7.00	0.62	1.5	3,298	2.02	1.08



---

***Particle Size Distribution(s) at Each Structure***

***Structure #1:***

Size (mm)	In/Out
1.4000	100.000%
1.0000	84.620%
0.0630	49.312%
0.0440	42.610%
0.0380	42.610%
0.0040	8.802%
0.0030	5.801%
0.0010	0.000%

***Structure Detail:***

***Structure #1 (Vegetated Channel)***

Trapezoidal Vegetated Channel Inputs:

**Material: Bermuda grass**

Bottom Width (ft)	Left Sideslope Ratio	Right Sideslope Ratio	Slope (%)	Retardance Classes	Freeboard Depth (ft)	Freeboard % of Depth	Freeboard Mult. x (VxD)	Limiting Velocity (fps)
2.00	3.0:1	3.0:1	2.5	C, B	0.50			8.0

Vegetated Channel Results:

	Stability Class C w/o Freeboard	Stability Class C w/ Freeboard	Capacity Class B w/o Freeboard	Capacity Class B w/ Freeboard
Design Discharge:	7.00 cfs		7.00 cfs	
Depth:	0.84 ft	1.34 ft	1.19 ft	1.69 ft
Top Width:	7.06 ft	10.06 ft	9.17 ft	12.17 ft
Velocity:	1.83 fps		1.05 fps	
X-Section Area:	3.82 sq ft		6.67 sq ft	
Hydraulic Radius:	0.521 ft		0.698 ft	
Froude Number:	0.44		0.22	
Roughness Coefficient:	0.0839		0.1782	

**Subwatershed Hydrology Detail:**

Stru #	SWS #	SWS Area (ac)	Time of Conc (hrs)	Musk K (hrs)	Musk X	Curve Number	UHS	Peak Discharge (cfs)	Runoff Volume (ac-ft)
#1	1	1.485	0.091	0.091	0.308	86.000	M	6.86	0.616
<b>Σ</b>		<b>1.485</b>						<b>7.00</b>	<b>0.616</b>

**Subwatershed Sedimentology Detail:**

Stru #	SWS #	Soil K	L (ft)	S (%)	C	P	PS #	Sediment (tons)	Peak Sediment Conc. (mg/l)	Peak Settleable Conc (ml/l)	24VW (ml/l)
#1	1	0.240	300.00	3.50	0.0500	1.0000	1	1.5	3,299	2.02	1.08
<b>Σ</b>								<b>1.5</b>	<b>3,298</b>	<b>2.02</b>	<b>1.08</b>

**Subwatershed Time of Concentration Details:**

Stru #	SWS #	Land Flow Condition	Slope (%)	Vert. Dist. (ft)	Horiz. Dist. (ft)	Velocity (fps)	Time (hrs)
#1	1	8. Large gullies, diversions, and low flowing streams	3.33	3.00	90.00	5.470	0.004
		6. Grassed waterway	2.54	19.04	749.60	2.390	0.087
<b>#1</b>	<b>1</b>	<b>Time of Concentration:</b>					<b>0.091</b>

**Subwatershed Muskingum Routing Details:**

Stru #	SWS #	Land Flow Condition	Slope (%)	Vert. Dist. (ft)	Horiz. Dist. (ft)	Velocity (fps)	Time (hrs)
#1	1	8. Large gullies, diversions, and low flowing streams	3.33	3.00	90.00	5.470	0.004
		6. Grassed waterway	2.54	19.04	749.60	2.390	0.087
<b>#1</b>	<b>1</b>	<b>Muskingum K:</b>					<b>0.091</b>

# **Perimeter Ditch 1 25-yr**

Davis & Floyd, Inc.  
1319 Hwy 72 221 E.  
Greenwood, SC 29649

Phone: 864-229-5211

## ***General Information***

### ***Storm Information:***

Storm Type:	NRCS Type II
Design Storm:	25 yr - 24 hr
Rainfall Depth:	6.600 inches

### ***Particle Size Distribution:***

Size (mm)	Madison
1.4000	100.000%
1.0000	84.600%
0.0630	49.300%
0.0440	42.600%
0.0380	42.600%
0.0040	8.800%
0.0030	5.800%
0.0010	0.000%

## Structure Networking:

Type	Stru #	(flows into)	Stru #	Musk. K (hrs)	Musk. X	Description
Channel	#1	==>	End	0.000	0.000	

#1  
Chan'l

***Structure Summary:***

	Immediate Contributing Area (ac)	Total Contributing Area (ac)	Peak Discharge (cfs)	Total Runoff Volume (ac-ft)	Sediment (tons)	Peak Sediment Conc. (mg/l)	Peak Settleable Conc. (ml/l)	24WW (ml/l)
#1	15.000	15.000	49.46	5.06	8.2	2,211	1.23	0.66

## ***Particle Size Distribution(s) at Each Structure***

### ***Structure #1:***

Size (mm)	In/Out
1.4000	100.000%
1.0000	100.000%
0.0630	66.485%
0.0440	57.449%
0.0380	57.449%
0.0040	11.867%
0.0030	7.822%
0.0010	0.000%



**Structure Detail:**

Structure #1 (Vegetated Channel)

Trapezoidal Vegetated Channel Inputs:

Material: Bermuda grass

Bottom Width (ft)	Left Sideslope Ratio	Right Sideslope Ratio	Slope (%)	Retardance Classes	Freeboard Depth (ft)	Freeboard % of Depth	Freeboard Mult. x (VxD)	Limiting Velocity (fps)
4.00	3.0:1	3.0:1	3.5	C, B	0.50			8.0

Vegetated Channel Results:

	Stability Class C w/o Freeboard	Stability Class C w/ Freeboard	Capacity Class B w/o Freeboard	Capacity Class B w/ Freeboard
Design Discharge:	49.46 cfs		49.46 cfs	
Depth:	1.26 ft	1.76 ft	1.60 ft	2.10 ft
Top Width:	11.54 ft	14.54 ft	13.57 ft	16.57 ft
Velocity:	5.07 fps		3.53 fps	
X-Section Area:	9.76 sq ft		14.01 sq ft	
Hydraulic Radius:	0.817 ft		0.995 ft	
Froude Number:	0.97		0.61	
Roughness Coefficient:	0.0476		0.0781	

**Subwatershed Hydrology Detail:**

Stru #	SWS #	SWS Area (ac)	Time of Conc (hrs)	Musk K (hrs)	Musk X	Curve Number	UHS	Peak Discharge (cfs)	Runoff Volume (ac-ft)
#1	1	15.000	0.138	0.138	0.316	86.000	M	50.93	5.060
<b>Σ</b>		<b>15.000</b>						<b>49.46</b>	<b>5.060</b>

**Subwatershed Sedimentology Detail:**

Stru #	SWS #	Soil K	L (ft)	S (%)	C	P	PS #	Sediment (tons)	Peak Sediment Conc. (mg/l)	Peak Settleable Conc (ml/l)	24VW (ml/l)
#1	1	0.240	200.00	2.11	0.0500	1.0000	1	9.2	2,509	1.46	0.78
<b>Σ</b>								<b>8.2</b>	<b>2,211</b>	<b>1.23</b>	<b>0.66</b>

**Subwatershed Time of Concentration Details:**

Stru #	SWS #	Land Flow Condition	Slope (%)	Vert. Dist. (ft)	Horiz. Dist. (ft)	Velocity (fps)	Time (hrs)
#1	1	3. Short grass pasture	33.00	12.00	36.36	4.590	0.002
		3. Short grass pasture	12.00	2.00	16.66	2.770	0.001
		3. Short grass pasture	33.00	26.00	78.78	4.590	0.004
		6. Grassed waterway	3.45	45.53	1,319.71	2.780	0.131
<b>#1</b>	<b>1</b>	<b>Time of Concentration:</b>					<b>0.138</b>

**Subwatershed Muskingum Routing Details:**

Stru #	SWS #	Land Flow Condition	Slope (%)	Vert. Dist. (ft)	Horiz. Dist. (ft)	Velocity (fps)	Time (hrs)
#1	1	3. Short grass pasture	33.00	12.00	36.36	4.590	0.002
		3. Short grass pasture	12.00	2.00	16.66	2.770	0.001
		3. Short grass pasture	33.00	26.00	78.78	4.590	0.004
		6. Grassed waterway	3.45	45.53	1,319.71	2.780	0.131
<b>#1</b>	<b>1</b>	<b>Muskingum K:</b>					<b>0.138</b>

# Perimeter Ditch 2 25-yr

Davis & Floyd, Inc.  
1319 Hwy 72 221 E.  
Greenwood, SC 29649

Phone: 864-229-5211

## ***General Information***

### ***Storm Information:***

Storm Type:	NRCS Type II
Design Storm:	25 yr - 24 hr
Rainfall Depth:	6.600 inches

### ***Particle Size Distribution:***

Size (mm)	Madison
1.4000	100.000%
1.0000	84.600%
0.0630	49.300%
0.0440	42.600%
0.0380	42.600%
0.0040	8.800%
0.0030	5.800%
0.0010	0.000%

**Structure Networking:**

Type	Stru #	(flows into)	Stru #	Musk. K (hrs)	Musk. X	Description
Channel	#1	==>	End	0.000	0.000	

#1  
Chan'

***Structure Summary:***

	Immediate Contributing Area (ac)	Total Contributing Area (ac)	Peak Discharge (cfs)	Total Runoff Volume (ac-ft)	Sediment (tons)	Peak Sediment Conc. (mg/l)	Peak Settleable Conc. (ml/l)	24VW (ml/l)
#1	13.000	13.000	58.83	5.39	14.2	3,557	2.17	1.18

***Particle Size Distribution(s) at Each Structure***

***Structure #1:***

Size (mm)	In/Out
1.4000	100.000%
1.0000	85.853%
0.0630	50.030%
0.0440	43.231%
0.0380	43.231%
0.0040	8.930%
0.0030	5.886%
0.0010	0.000%

**Structure Detail:**

Structure #1 (Vegetated Channel)

Trapezoidal Vegetated Channel Inputs:

Material: Bermuda grass

Bottom Width (ft)	Left Sideslope Ratio	Right Sideslope Ratio	Slope (%)	Retardance Classes	Freeboard Depth (ft)	Freeboard % of Depth	Freeboard Mult. x (VxD)	Limiting Velocity (fps)
4.00	3.0:1	3.0:1	4.1	C, B	0.50			8.0

Vegetated Channel Results:

	Stability Class C w/o Freeboard	Stability Class C w/ Freeboard	Capacity Class B w/o Freeboard	Capacity Class B w/ Freeboard
Design Discharge:	58.83 cfs		58.83 cfs	
Depth:	1.27 ft	1.77 ft	1.59 ft	2.09 ft
Top Width:	11.60 ft	14.60 ft	13.52 ft	16.52 ft
Velocity:	5.95 fps		4.23 fps	
X-Section Area:	9.88 sq ft		13.90 sq ft	
Hydraulic Radius:	0.823 ft		0.991 ft	
Froude Number:	1.14		0.74	
Roughness Coefficient:	0.0447		0.0711	



**Subwatershed Hydrology Detail:**

Stru #	SWS #	SWS Area (ac)	Time of Conc (hrs)	Musk K (hrs)	Musk X	Curve Number	UHS	Peak Discharge (cfs)	Runoff Volume (ac-ft)
#1	1	13.000	0.114	0.114	0.326	86.000	M	60.07	5.393
<b>Σ</b>		<b>13.000</b>						<b>58.83</b>	<b>5.393</b>

**Subwatershed Sedimentology Detail:**

Stru #	SWS #	Soil K	L (ft)	S (%)	C	P	PS #	Sediment (tons)	Peak Sediment Conc. (mg/l)	Peak Settleable Conc (ml/l)	24VV (ml/l)
#1	1	0.240	200.00	3.40	0.0500	1.0000	1	14.4	3,609	2.21	1.21
<b>Σ</b>								<b>14.2</b>	<b>3,557</b>	<b>2.17</b>	<b>1.18</b>

**Subwatershed Time of Concentration Details:**

Stru #	SWS #	Land Flow Condition	Slope (%)	Vert. Dist. (ft)	Horiz. Dist. (ft)	Velocity (fps)	Time (hrs)
#1	1	3. Short grass pasture	33.00	12.00	36.36	4.590	0.002
		3. Short grass pasture	12.00	2.00	16.66	2.770	0.001
		3. Short grass pasture	33.00	26.00	78.78	4.590	0.004
		6. Grassed waterway	4.14	48.68	1,176.00	3.050	0.107
<b>#1</b>	<b>1</b>	<b>Time of Concentration:</b>					<b>0.114</b>

**Subwatershed Muskingum Routing Details:**

Stru #	SWS #	Land Flow Condition	Slope (%)	Vert. Dist. (ft)	Horiz. Dist. (ft)	Velocity (fps)	Time (hrs)
#1	1	3. Short grass pasture	33.00	12.00	36.36	4.590	0.002
		3. Short grass pasture	12.00	2.00	16.66	2.770	0.001
		3. Short grass pasture	33.00	26.00	78.78	4.590	0.004
		6. Grassed waterway	4.14	48.68	1,175.84	3.050	0.107
<b>#1</b>	<b>1</b>	<b>Muskingum K:</b>					<b>0.114</b>

# Pond 1 2 yr

Davis & Floyd, Inc.  
1319 Hwy 72 221 E.  
Greenwood, SC 29649

Phone: 864-229-5211

## ***General Information***

### ***Storm Information:***

Storm Type:	NRCS Type II
Design Storm:	2 yr - 24 hr
Rainfall Depth:	3.600 inches

### ***Particle Size Distribution:***

Size (mm)	Madison
1.4000	100.000%
1.0000	84.600%
0.0630	49.300%
0.0440	42.600%
0.0380	42.600%
0.0040	8.800%
0.0030	5.800%
0.0010	0.000%

**Structure Networking:**

Type	Stru #	(flows into)	Stru #	Musk. K (hrs)	Musk. X	Description
Pond	#1	==>	End	0.000	0.000	

#1  
Pond

***Structure Summary:***

	Immediate Contributing Area (ac)	Total Contributing Area (ac)	Peak Discharge (cfs)	Total Runoff Volume (ac-ft)	Sediment (tons)	Peak Sediment Conc. (mg/l)	Peak Settleable Conc. (ml/l)	24VW (ml/l)
#1 In	15.000	15.000	22.58	2.22	6.5	4,027	2.21	1.19
Out			0.77	2.07	0.5	1,077	0.00	0.00

**Particle Size Distribution(s) at Each Structure**

**Structure #1:**

Size (mm)	In	Out
1.4000	100.000%	100.000%
1.0000	100.000%	100.000%
0.0630	68.069%	100.000%
0.0440	58.818%	100.000%
0.0380	58.818%	100.000%
0.0040	12.150%	100.000%
0.0030	8.008%	100.000%
0.0010	0.000%	0.000%

### Structure Detail:

#### Structure #1 (Pond)

##### Pond Inputs:

Initial Pool Elev:	807.01 ft
Initial Pool:	0.00 ac-ft
*Sediment Storage:	0.00 ac-ft
Dead Space:	20.00 %

*\*No sediment capacity defined*

#### Perforated Riser

Riser Diameter (in)	Riser Height (ft)	Barrel Diameter (in)	Barrel Length (ft)	Barrel Slope (%)	Manning's n	Spillway Elev (ft)	Number of Holes per Elev
48.00	6.00	18.00	50.00	1.00	0.0240	813.00	4

#### Emergency Spillway

Spillway Elev	Crest Length (ft)	Left Sideslope	Right Sideslope	Bottom Width (ft)
813.50	30.00	3.00:1	3.00:1	20.00

##### Pond Results:

Peak Elevation:	810.34 ft
H'graph Detention Time:	14.61 hrs
Pond Model:	CSTRS
Dewater Time:	1.53 days
Trap Efficiency:	92.37 %

*Dewatering time is calculated from peak stage to lowest spillway*

#### Elevation-Capacity-Discharge Table

Elevation	Area (ac)	Capacity (ac-ft)	Discharge (cfs)	Dewater Time (hrs)
807.00	0.000	0.000	0.000	Top of Sed. Storage
807.01	0.000	0.000	0.000	Low hole SPW #1
807.50	0.128	0.022	0.294	0.89*
808.00	0.503	0.169	0.418	4.27*
808.50	0.530	0.427	0.513	6.75
809.00	0.558	0.699	0.593	5.95
809.50	0.587	0.986	0.663	5.55

Elevation	Area (ac)	Capacity (ac-ft)	Discharge (cfs)	Dewater Time (hrs)
810.00	0.618	1.287	0.727	5.25
810.34	0.639	1.503	0.766	8.10 Peak Stage
810.50	0.649	1.604	0.785	
811.00	0.681	1.936	0.839	
811.50	0.721	2.287	0.890	
812.00	0.763	2.658	0.939	
812.50	0.804	3.049	0.985	
813.00	0.847	3.462	1.028	Spillway #1
813.50	0.901	3.899	13.773	Spillway #2
814.00	0.956	4.364	38.898	
814.50	0.960	4.843	61.932	

\*Designates time(s) to dewater have been extrapolated beyond the 50 hour hydrograph limit.

Detailed Discharge Table

Elevation (ft)	Perf. Riser (cfs)	Emergency Spillway (cfs)	Combined Total Discharge (cfs)
807.00	0.000	0.000	0.000
807.01	2.00	0.000	0.000
807.50	0.294	0.000	0.294
808.00	0.418	0.000	0.418
808.50	0.513	0.000	0.513
809.00	0.593	0.000	0.593
809.50	0.663	0.000	0.663
810.00	0.727	0.000	0.727
810.50	0.785	0.000	0.785
811.00	0.839	0.000	0.839
811.50	0.890	0.000	0.890
812.00	0.939	0.000	0.939
812.50	0.985	0.000	0.985
813.00	1.028	0.000	1.028
813.50	13.773	0.000	13.773
814.00	16.402	22.496	38.898
814.50	16.940	44.992	61.932



**Subwatershed Hydrology Detail:**

Stru #	SWS #	SWS Area (ac)	Time of Conc (hrs)	Musk K (hrs)	Musk X	Curve Number	UHS	Peak Discharge (cfs)	Runoff Volume (ac-ft)
#1	1	15.000	0.137	0.138	0.316	86.000	M	23.23	2.222
<b>Σ</b>		<b>15.000</b>						<b>22.58</b>	<b>2.222</b>

**Subwatershed Sedimentology Detail:**

Stru #	SWS #	Soil K	L (ft)	S (%)	C	P	PS #	Sediment (tons)	Peak Sediment Conc. (mg/l)	Peak Settleable Conc (m/l)	24VV (ml/l)
#1	1	0.240	500.00	3.30	0.0500	1.0000	1	7.4	4,566	2.63	1.41
<b>Σ</b>								<b>6.5</b>	<b>4,027</b>	<b>2.21</b>	<b>1.19</b>

**Subwatershed Time of Concentration Details:**

Stru #	SWS #	Land Flow Condition	Slope (%)	Vert. Dist. (ft)	Horiz. Dist. (ft)	Velocity (fps)	Time (hrs)
#1	1	3. Short grass pasture	33.00	12.00	36.36	4.590	0.002
		3. Short grass pasture	12.00	2.00	16.66	2.770	0.001
		3. Short grass pasture	33.00	26.00	78.78	4.590	0.004
		6. Grassed waterway	3.54	46.72	1,320.00	2.820	0.130
<b>#1</b>	<b>1</b>	<b>Time of Concentration:</b>					<b>0.137</b>

**Subwatershed Muskingum Routing Details:**

Stru #	SWS #	Land Flow Condition	Slope (%)	Vert. Dist. (ft)	Horiz. Dist. (ft)	Velocity (fps)	Time (hrs)
#1	1	3. Short grass pasture	33.00	12.00	36.36	4.590	0.002
		3. Short grass pasture	12.00	2.00	16.66	2.770	0.001
		3. Short grass pasture	33.00	26.00	78.78	4.590	0.004
		6. Grassed waterway	3.45	45.53	1,320.00	2.780	0.131
<b>#1</b>	<b>1</b>	<b>Muskingum K:</b>					<b>0.138</b>

# **Pond 1 10 yr**

Davis & Floyd, Inc.  
1319 Hwy 72 221 E.  
Greenwood, SC 29649

Phone: 864-229-5211

***General Information***

***Storm Information:***

Storm Type:	NRCS Type II
Design Storm:	10 yr - 24 hr
Rainfall Depth:	5.500 inches

***Particle Size Distribution:***

Size (mm)	Madison
1.4000	100.000%
1.0000	84.600%
0.0630	49.300%
0.0440	42.600%
0.0380	42.600%
0.0040	8.800%
0.0030	5.800%
0.0010	0.000%

**Structure Networking:**

Type	Stru #	(flows into)	Stru #	Musk. K (hrs)	Musk. X	Description
Pond	#1	==>	End	0.000	0.000	

#1  
Pond

***Structure Summary:***

		Immediate Contributing Area (ac)	Total Contributing Area (ac)	Peak Discharge (cfs)	Total Runoff Volume (ac-ft)	Sediment (tons)	Peak Sediment Conc. (mg/l)	Peak Settleable Conc. (ml/l)	24VW (ml/l)
#1	In	15.000	15.000	39.60	4.00	12.4	4,261	2.36	1.26
	Out			0.97	2.88	1.1	1,191	0.00	0.00

***Particle Size Distribution(s) at Each Structure***

***Structure #1:***

Size (mm)	In	Out
1.4000	100.000%	100.000%
1.0000	100.000%	100.000%
0.0630	66.863%	100.000%
0.0440	57.776%	100.000%
0.0380	57.776%	100.000%
0.0040	11.935%	100.000%
0.0030	7.866%	92.625%
0.0010	0.000%	0.000%

### Structure Detail:

#### Structure #1 (Pond)

Pond Inputs:

Initial Pool Elev:	807.01 ft
Initial Pool:	0.00 ac-ft
*Sediment Storage:	0.00 ac-ft
Dead Space:	20.00 %

*\*No sediment capacity defined*

#### Perforated Riser

Riser Diameter (in)	Riser Height (ft)	Barrel Diameter (in)	Barrel Length (ft)	Barrel Slope (%)	Manning's n	Spillway Elev (ft)	Number of Holes per Elev
48.00	6.00	18.00	50.00	1.00	0.0240	813.00	4

#### Emergency Spillway

Spillway Elev	Crest Length (ft)	Left Sideslope	Right Sideslope	Bottom Width (ft)
813.50	30.00	3.00:1	3.00:1	20.00

Pond Results:

Peak Elevation:	812.37 ft
H'graph Detention Time:	15.39 hrs
Pond Model:	CSTRS
Dewater Time:	2.28 days
Trap Efficiency:	91.51 %

*Dewatering time is calculated from peak stage to lowest spillway*

#### Elevation-Capacity-Discharge Table

Elevation	Area (ac)	Capacity (ac-ft)	Discharge (cfs)	Dewater Time (hrs)
807.00	0.000	0.000	0.000	Top of Sed. Storage
807.01	0.000	0.000	0.000	Low hole SPW #1
807.50	0.128	0.022	0.294	0.89*
808.00	0.503	0.169	0.418	4.27*
808.50	0.530	0.427	0.513	6.09*
809.00	0.558	0.699	0.593	5.55*
809.50	0.587	0.986	0.663	5.22*

Elevation	Area (ac)	Capacity (ac-ft)	Discharge (cfs)	Dewater Time (hrs)
810.00	0.618	1.287	0.727	5.02*
810.50	0.649	1.604	0.785	5.05
811.00	0.681	1.936	0.839	4.95
811.50	0.721	2.287	0.890	4.90
812.00	0.763	2.658	0.939	4.95
812.37	0.794	2.949	0.973	7.80 Peak Stage
812.50	0.804	3.049	0.985	
813.00	0.847	3.462	1.028	Spillway #1
813.50	0.901	3.899	13.773	Spillway #2
814.00	0.956	4.364	38.898	
814.50	0.960	4.843	61.932	

\*Designates time(s) to dewater have been extrapolated beyond the 50 hour hydrograph limit.

Detailed Discharge Table

Elevation (ft)	Perf. Riser (cfs)	Emergency Spillway (cfs)	Combined Total Discharge (cfs)
807.00	0.000	0.000	0.000
807.01	2.00	0.000	0.000
807.50	0.294	0.000	0.294
808.00	0.418	0.000	0.418
808.50	0.513	0.000	0.513
809.00	0.593	0.000	0.593
809.50	0.663	0.000	0.663
810.00	0.727	0.000	0.727
810.50	0.785	0.000	0.785
811.00	0.839	0.000	0.839
811.50	0.890	0.000	0.890
812.00	0.939	0.000	0.939
812.50	0.985	0.000	0.985
813.00	1.028	0.000	1.028
813.50	13.773	0.000	13.773
814.00	16.402	22.496	38.898
814.50	16.940	44.992	61.932



**Subwatershed Hydrology Detail:**

Stru #	SWS #	SWS Area (ac)	Time of Conc (hrs)	Musk K (hrs)	Musk X	Curve Number	UHS	Peak Discharge (cfs)	Runoff Volume (ac-ft)
#1	1	15.000	0.137	0.138	0.316	86.000	M	40.76	3.998
<b>Σ</b>		<b>15.000</b>						<b>39.60</b>	<b>3.998</b>

**Subwatershed Sedimentology Detail:**

Stru #	SWS #	Soil K	L (ft)	S (%)	C	P	PS #	Sediment (tons)	Peak Sediment Conc. (mg/l)	Peak Settleable Conc. (ml/l)	24VW (ml/l)
#1	1	0.240	500.00	3.30	0.0500	1.0000	1	14.1	4,834	2.80	1.50
<b>Σ</b>								<b>12.4</b>	<b>4,261</b>	<b>2.36</b>	<b>1.26</b>

**Subwatershed Time of Concentration Details:**

Stru #	SWS #	Land Flow Condition	Slope (%)	Vert. Dist. (ft)	Horiz. Dist. (ft)	Velocity (fps)	Time (hrs)
#1	1	3. Short grass pasture	33.00	12.00	36.36	4.590	0.002
		3. Short grass pasture	12.00	2.00	16.66	2.770	0.001
		3. Short grass pasture	33.00	26.00	78.78	4.590	0.004
		6. Grassed waterway	3.54	46.72	1,320.00	2.820	0.130
<b>#1</b>	<b>1</b>	<b>Time of Concentration:</b>					<b>0.137</b>

**Subwatershed Muskingum Routing Details:**

Stru #	SWS #	Land Flow Condition	Slope (%)	Vert. Dist. (ft)	Horiz. Dist. (ft)	Velocity (fps)	Time (hrs)
#1	1	3. Short grass pasture	33.00	12.00	36.36	4.590	0.002
		3. Short grass pasture	12.00	2.00	16.66	2.770	0.001
		3. Short grass pasture	33.00	26.00	78.78	4.590	0.004
		6. Grassed waterway	3.45	45.53	1,320.00	2.780	0.131
<b>#1</b>	<b>1</b>	<b>Muskingum K:</b>					<b>0.138</b>

# Inflow/Outflow Hydrographs for Structure # 1

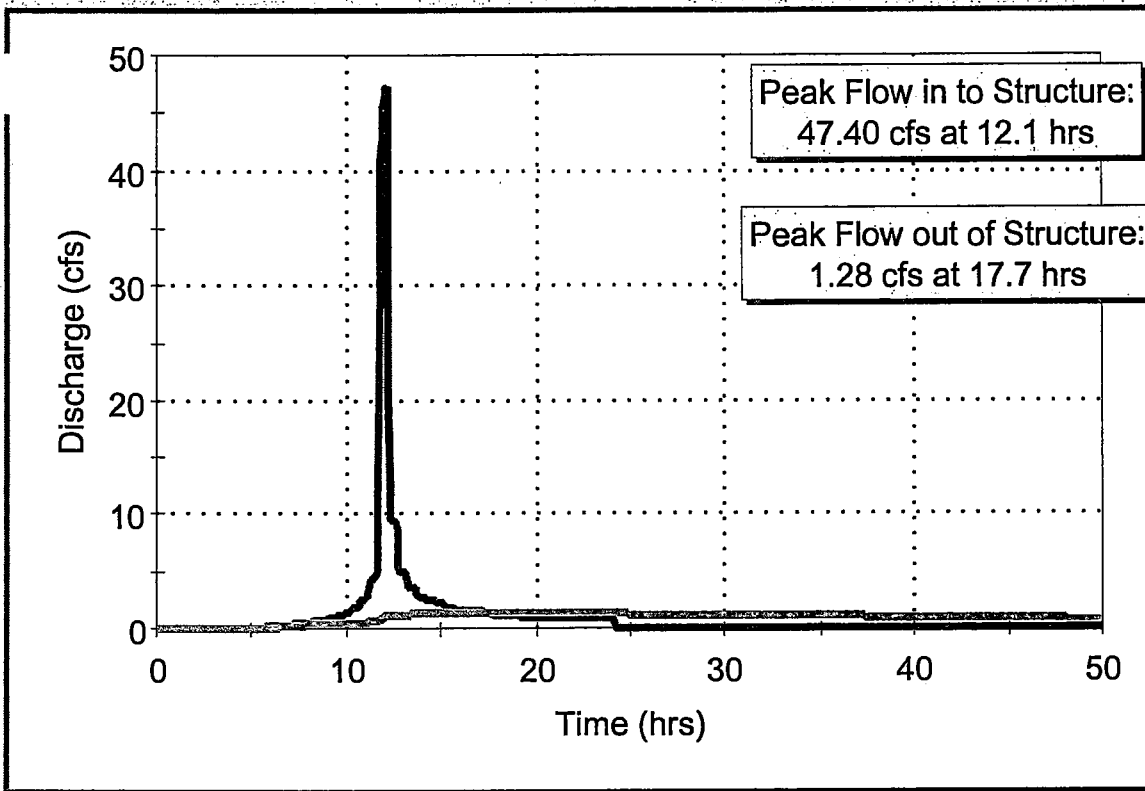

— Inflow  
- - - Outflow

**RECEIVED**

MAY 19 2008

DIVISION OF MINING &  
SOLID WASTE MANAGEMENT  
BLYNN

**Pond 1 25 yr**

Davis & Floyd, Inc.  
1319 Hwy 72 221 E.  
Greenwood, SC 29649

Phone: 864-229-5211

***General Information***

***Storm Information:***

Storm Type:	NRCS Type II
Design Storm:	25 yr - 24 hr
Rainfall Depth:	6.600 inches

***Particle Size Distribution:***

Size (mm)	Madison
1.4000	100.000%
1.0000	84.600%
0.0630	49.300%
0.0440	42.600%
0.0380	42.600%
0.0040	8.800%
0.0030	5.800%
0.0010	0.000%

**Structure Networking:**

Type	Stru #	(flows into)	Stru #	Musk. K (hrs)	Musk. X	Description
Pond	#1	==>	End	0.000	0.000	



***Structure Summary:***

	Immediate Contributing Area (ac)	Total Contributing Area (ac)	Peak Discharge (cfs)	Total Runoff Volume (ac-ft)	Sediment (tons)	Peak Sediment Conc. (mg/l)	Peak Settleable Conc. (ml/l)	24VW (ml/l)
#1 In	15.000	15.000	49.46	5.06	16.1	4,360	2.42	1.29
Out			2.63	3.54	1.6	1,192	0.00	0.00

***Particle Size Distribution(s) at Each Structure***

***Structure #1:***

Size (mm)	In	Out
1.4000	100.000%	100.000%
1.0000	100.000%	100.000%
0.0630	66.485%	100.000%
0.0440	57.449%	100.000%
0.0380	57.449%	100.000%
0.0040	11.867%	100.000%
0.0030	7.822%	79.942%
0.0010	0.000%	0.000%

**Structure Detail:**

Structure #1 (Pond)

Pond Inputs:

Initial Pool Elev:	807.01 ft
Initial Pool:	0.00 ac-ft
*Sediment Storage:	0.00 ac-ft
Dead Space:	20.00 %

*\*No sediment capacity defined*

Perforated Riser

Riser Diameter (in)	Riser Height (ft)	Barrel Diameter (in)	Barrel Length (ft)	Barrel Slope (%)	Manning's n	Spillway Elev (ft)	Number of Holes per Elev
48.00	6.00	18.00	50.00	1.00	0.0240	813.00	4

Emergency Spillway

Spillway Elev	Crest Length (ft)	Left Sideslope	Right Sideslope	Bottom Width (ft)
813.50	30.00	3.00:1	3.00:1	20.00

Pond Results:

Peak Elevation:	813.06 ft
H'graph Detention Time:	13.99 hrs
Pond Model:	CSTRS
Dewater Time:	2.74 days
Trap Efficiency:	90.22 %

*Dewatering time is calculated from peak stage to lowest spillway*

Elevation-Capacity-Discharge Table

Elevation	Area (ac)	Capacity (ac-ft)	Discharge (cfs)	Dewater Time (hrs)
807.00	0.000	0.000	0.000	Top of Sed. Storage
807.01	0.000	0.000	0.000	Low hole SPW #1
807.50	0.128	0.022	0.294	0.89*
808.00	0.503	0.169	0.418	4.27*
808.50	0.530	0.427	0.513	6.09*
809.00	0.558	0.699	0.593	5.55*
809.50	0.587	0.986	0.663	5.22*



Elevation	Area (ac)	Capacity (ac-ft)	Discharge (cfs)	Dewater Time (hrs)	
810.00	0.618	1.287	0.727	5.02*	
810.50	0.649	1.604	0.785	4.88*	
811.00	0.681	1.936	0.839	5.00	
811.50	0.721	2.287	0.890	4.90	
812.00	0.763	2.658	0.939	4.90	
812.50	0.804	3.049	0.985	4.90	
813.00	0.847	3.462	1.028	8.40	Spillway #1
813.06	0.859	3.517	2.630	5.75	Peak Stage
813.50	0.901	3.899	13.773		Spillway #2
814.00	0.956	4.364	38.898		
814.50	0.960	4.843	61.932		

\*Designates time(s) to dewater have been extrapolated beyond the 50 hour hydrograph limit.

Detailed Discharge Table

Elevation (ft)	Perf. Riser (cfs)	Emergency Spillway (cfs)	Combined Total Discharge (cfs)
807.00	0.000	0.000	0.000
807.01	2.00	0.000	0.000
807.50	0.294	0.000	0.294
808.00	0.418	0.000	0.418
808.50	0.513	0.000	0.513
809.00	0.593	0.000	0.593
809.50	0.663	0.000	0.663
810.00	0.727	0.000	0.727
810.50	0.785	0.000	0.785
811.00	0.839	0.000	0.839
811.50	0.890	0.000	0.890
812.00	0.939	0.000	0.939
812.50	0.985	0.000	0.985
813.00	1.028	0.000	1.028
813.50	13.773	0.000	13.773
814.00	16.402	22.496	38.898
814.50	16.940	44.992	61.932

**Subwatershed Hydrology Detail:**

Stru #	SWS #	SWS Area (ac)	Time of Conc (hrs)	Musk K (hrs)	Musk X	Curve Number	UHS	Peak Discharge (cfs)	Runoff Volume (ac-ft)
#1	1	15.000	0.137	0.138	0.316	86.000	M	50.93	5.060
<b>Σ</b>		<b>15.000</b>						<b>49.46</b>	<b>5.060</b>

**Subwatershed Sedimentology Detail:**

Stru #	SWS #	Soil K	L (ft)	S (%)	C	P	PS #	Sediment (tons)	Peak Sediment Conc. (mg/l)	Peak Settleable Conc. (ml/l)	24VW (ml/l)
#1	1	0.240	500.00	3.30	0.0500	1.0000	1	18.3	4,947	2.88	1.54
<b>Σ</b>								<b>16.1</b>	<b>4,360</b>	<b>2.42</b>	<b>1.29</b>

**Subwatershed Time of Concentration Details:**

Stru #	SWS #	Land Flow Condition	Slope (%)	Vert. Dist. (ft)	Horiz. Dist. (ft)	Velocity (fps)	Time (hrs)
#1	1	3. Short grass pasture	33.00	12.00	36.36	4.590	0.002
		3. Short grass pasture	12.00	2.00	16.66	2.770	0.001
		3. Short grass pasture	33.00	26.00	78.78	4.590	0.004
		6. Grassed waterway	3.54	46.72	1,320.00	2.820	0.130
<b>#1</b>	<b>1</b>	<b>Time of Concentration:</b>					<b>0.137</b>

**Subwatershed Muskingum Routing Details:**

Stru #	SWS #	Land Flow Condition	Slope (%)	Vert. Dist. (ft)	Horiz. Dist. (ft)	Velocity (fps)	Time (hrs)
#1	1	3. Short grass pasture	33.00	12.00	36.36	4.590	0.002
		3. Short grass pasture	12.00	2.00	16.66	2.770	0.001
		3. Short grass pasture	33.00	26.00	78.78	4.590	0.004
		6. Grassed waterway	3.45	45.53	1,320.00	2.780	0.131
<b>#1</b>	<b>1</b>	<b>Muskingum K:</b>					<b>0.138</b>

# Inflow/Outflow Hydrographs for Structure # 1

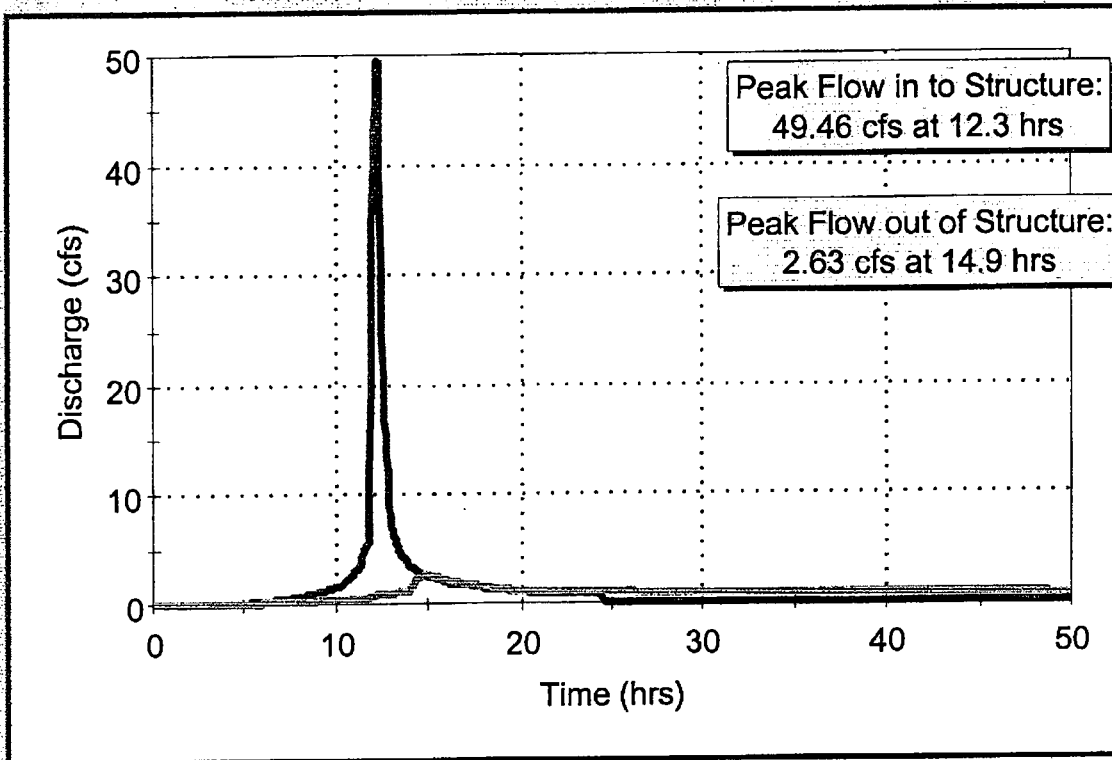

— Inflow  
— Outflow

Type.... 1st Flush

Name.... BMP1ST 1

File.... H:\JOBSODD\11967-00\C\Ponds\New Design\Pond 15 ac.ppw

---

BMP FIRST FLUSH CALCULATIONS

First Flush Depth = 1.0000 in  
Drainage Area = 15.000 acres

Volume = Flush Depth \* Drainage Area

-----  
First Flush volume = 1.250 ac-ft  
-----

TIME vs. VOLUME (ac-ft)

Time hrs	Output Time increment = .5000 hrs				
	Time on left represents time for first value in each row.				
.0000	1.286	1.257	1.229	1.202	1.175
2.5000	1.148	1.122	1.096	1.071	1.046
5.0000	1.021	.997	.972	.948	.924
7.5000	.900	.877	.855	.833	.812
10.0000	.791	.770	.750	.730	.711
12.5000	.692	.672	.653	.633	.614
15.0000	.594	.575	.556	.537	.518
17.5000	.499	.480	.461	.442	.423
20.0000	.404	.385	.367	.349	.331
22.5000	.314	.298	.282	.266	.251
25.0000	.236	.222	.208	.194	.180
27.5000	.167	.146	.128	.112	.098
30.0000	.086	.076	.066	.058	.051
32.5000	.045	.040	.035	.031	.028
35.0000	.025	.022	.013	.006	.003
37.5000	.001	.001	.000	.000	.000
40.0000	.000	.000	.000	.000	.000
42.5000	.000	.000			

# Pond 2 2yr

Davis & Floyd, Inc.  
1319 Hwy 72 221 E.  
Greenwood, SC 29649

Phone: 864-229-5211

---

***General Information***

***Storm Information:***

Storm Type:	NRCS Type II
Design Storm:	2 yr - 24 hr
Rainfall Depth:	3.600 inches

***Particle Size Distribution:***

Size (mm)	Madison
1.4000	100.000%
1.0000	84.600%
0.0630	49.300%
0.0440	42.600%
0.0380	42.600%
0.0040	8.800%
0.0030	5.800%
0.0010	0.000%

### Structure Networking:

Type	Stru #	(flows into)	Stru #	Musk. K (hrs)	Musk. X	Description
Pond	#1	==>	End	0.000	0.000	





***Structure Summary:***

		Immediate Contributing Area (ac)	Total Contributing Area (ac)	Peak Discharge (cfs)	Total Runoff Volume (ac-ft)	Sediment (tons)	Peak Sediment Conc. (mg/l)	Peak Settleable Conc. (ml/l)	24VW (ml/l)
#1	In	13.000	13.000	27.58	2.37	2.0	1,180	0.72	0.39
	Out			0.99	2.37	0.1	245	0.00	0.00

***Particle Size Distribution(s) at Each Structure******Structure #1:***

Size (mm)	In	Out
1.4000	100.000%	100.000%
1.0000	87.125%	100.000%
0.0630	50.771%	100.000%
0.0440	43.871%	100.000%
0.0380	43.871%	100.000%
0.0040	9.063%	100.000%
0.0030	5.973%	93.703%
0.0010	0.000%	0.000%

### Structure Detail:

#### Structure #1 (Pond)

##### Pond Inputs:

Initial Pool Elev:	798.01 ft
Initial Pool:	0.00 ac-ft
*Sediment Storage:	0.00 ac-ft
Dead Space:	20.00 %

*\*No sediment capacity defined*

#### Perforated Riser

Riser Diameter (in)	Riser Height (ft)	Barrel Diameter (in)	Barrel Length (ft)	Barrel Slope (%)	Manning's n	Spillway Elev (ft)	Number of Holes per Elev
48.00	8.00	18.00	300.00	0.50	0.0240	804.00	5

#### Emergency Spillway

Spillway Elev	Crest Length (ft)	Left Sideslope	Right Sideslope	Bottom Width (ft)
805.00	20.00	3.00:1	3.00:1	40.00

##### Pond Results:

Peak Elevation:	801.60 ft
H'graph Detention Time:	12.82 hrs
Pond Model:	CSTRS
Dewater Time:	1.41 days
Trap Efficiency:	93.63 %

*Dewatering time is calculated from peak stage to lowest spillway*

#### Elevation-Capacity-Discharge Table

Elevation	Area (ac)	Capacity (ac-ft)	Discharge (cfs)	Dewater Time (hrs)
798.00	0.000	0.000	0.000	Top of Sed. Storage
798.01	0.001	0.000	0.000	Low hole SPW #1
798.50	0.126	0.023	0.368	3.15
799.00	0.464	0.161	0.523	3.80
799.50	0.486	0.399	0.641	5.00
800.00	0.508	0.647	0.741	4.35
800.50	0.531	0.907	0.829	4.00

Elevation	Area (ac)	Capacity (ac-ft)	Discharge (cfs)	Dewater Time (hrs)
801.00	0.554	1.178	0.908	3.80
801.50	0.578	1.461	0.981	6.10
801.60	0.583	1.519	0.994	3.70 Peak Stage
802.00	0.602	1.756	1.049	
802.50	0.626	2.063	1.113	
803.00	0.651	2.383	1.173	
803.50	0.676	2.714	1.231	
804.00	0.702	3.059	1.285	Spillway #1
804.50	0.728	3.417	9.754	
805.00	0.754	3.787	9.995	Spillway #2
805.50	0.781	4.171	17.462	
806.00	0.809	4.568	105.988	
806.50	0.836	4.979	205.839	

### Detailed Discharge Table

Elevation (ft)	Perf. Riser (cfs)	Emergency Spillway (cfs)	Combined Total Discharge (cfs)
798.00	0.000	0.000	0.000
798.01	2.00	0.000	0.000
798.50	0.368	0.000	0.368
799.00	0.523	0.000	0.523
799.50	0.641	0.000	0.641
800.00	0.741	0.000	0.741
800.50	0.829	0.000	0.829
801.00	0.908	0.000	0.908
801.50	0.981	0.000	0.981
802.00	1.049	0.000	1.049
802.50	1.113	0.000	1.113
803.00	1.173	0.000	1.173
803.50	1.231	0.000	1.231
804.00	1.285	0.000	1.285
804.50	9.754	0.000	9.754
805.00	9.995	0.000	9.995
805.50	10.230	7.232	17.462
806.00	10.460	95.528	105.988
806.50	10.685	195.154	205.839

**Subwatershed Hydrology Detail:**

Stru #	SWS #	SWS Area (ac)	Time of Conc (hrs)	Musk K (hrs)	Musk X	Curve Number	UHS	Peak Discharge (cfs)	Runoff Volume (ac-ft)
#1	1	13.000	0.114	0.114	0.326	86.000	M	28.60	2.367
<b>Σ</b>		<b>13.000</b>						<b>27.58</b>	<b>2.367</b>

**Subwatershed Sedimentology Detail:**

Stru #	SWS #	Soil K	L (ft)	S (%)	C	P	PS #	Sediment (tons)	Peak Sediment Conc. (mg/l)	Peak Settleable Conc (ml/l)	24VW (ml/l)
#1	1	0.240	4.00	3.90	0.0500	1.0000	1	2.1	1,215	0.75	0.40
<b>Σ</b>								<b>2.0</b>	<b>1,180</b>	<b>0.72</b>	<b>0.39</b>

**Subwatershed Time of Concentration Details:**

Stru #	SWS #	Land Flow Condition	Slope (%)	Vert. Dist. (ft)	Horiz. Dist. (ft)	Velocity (fps)	Time (hrs)
#1	1	3. Short grass pasture	33.00	12.00	36.36	4.590	0.002
		3. Short grass pasture	12.00	2.00	16.66	2.770	0.001
		3. Short grass pasture	33.00	26.00	78.78	4.590	0.004
		6. Grassed waterway	4.14	48.68	1,176.00	3.050	0.107
<b>#1</b>	<b>1</b>	<b>Time of Concentration:</b>					<b>0.114</b>

**Subwatershed Muskingum Routing Details:**

Stru #	SWS #	Land Flow Condition	Slope (%)	Vert. Dist. (ft)	Horiz. Dist. (ft)	Velocity (fps)	Time (hrs)
#1	1	3. Short grass pasture	33.00	12.00	36.36	4.590	0.002
		3. Short grass pasture	12.00	2.00	16.66	2.770	0.001
		3. Short grass pasture	33.00	26.00	78.78	4.590	0.004
		6. Grassed waterway	4.14	48.68	1,176.00	3.050	0.107
<b>#1</b>	<b>1</b>	<b>Muskingum K:</b>					<b>0.114</b>

# Pond 2 10yr

Davis & Floyd, Inc.  
1319 Hwy 72 221 E.  
Greenwood, SC 29649

Phone: 864-229-5211

## ***General Information***

### ***Storm Information:***

Storm Type:	NRCS Type II
Design Storm:	10 yr - 24 hr
Rainfall Depth:	5.500 inches

### ***Particle Size Distribution:***

Size (mm)	Madison
1.4000	100.000%
1.0000	84.600%
0.0630	49.300%
0.0440	42.600%
0.0380	42.600%
0.0040	8.800%
0.0030	5.800%
0.0010	0.000%

**Structure Networking:**

Type	Stru #	(flows into)	Stru #	Musk. K (hrs)	Musk. X	Description
Pond	#1	==>	End	0.000	0.000	





***Structure Summary:***

	Immediate Contributing Area (ac)	Total Contributing Area (ac)	Peak Discharge (cfs)	Total Runoff Volume (ac-ft)	Sediment (tons)	Peak Sediment Conc. (mg/l)	Peak Settleable Conc. (ml/l)	24VW (ml/l)
#1 In			47.40	4.26	3.9	1,233	0.75	0.41
Out	13.000	13.000	1.28	3.60	0.3	280	0.00	0.00

***Particle Size Distribution(s) at Each Structure***

***Structure #1:***

Size (mm)	In	Out
1.4000	100.000%	100.000%
1.0000	85.853%	100.000%
0.0630	50.030%	100.000%
0.0440	43.231%	100.000%
0.0380	43.231%	100.000%
0.0040	8.930%	100.000%
0.0030	5.886%	74.800%
0.0010	0.000%	0.000%

### Structure Detail:

#### Structure #1 (Pond)

##### Pond Inputs:

Initial Pool Elev:	798.01 ft
Initial Pool:	0.00 ac-ft
*Sediment Storage:	0.00 ac-ft
Dead Space:	20.00 %

*\*No sediment capacity defined*

#### Perforated Riser

Riser Diameter (in)	Riser Height (ft)	Barrel Diameter (in)	Barrel Length (ft)	Barrel Slope (%)	Manning's n	Spillway Elev (ft)	Number of Holes per Elev
48.00	8.00	18.00	300.00	0.50	0.0240	804.00	5

#### Emergency Spillway

Spillway Elev	Crest Length (ft)	Left Sideslope	Right Sideslope	Bottom Width (ft)
805.00	20.00	3.00:1	3.00:1	40.00

##### Pond Results:

Peak Elevation:	803.91 ft
H'graph Detention Time:	14.97 hrs
Pond Model:	CSTRS
Dewater Time:	1.86 days
Trap Efficiency:	92.13 %

*Dewatering time is calculated from peak stage to lowest spillway*

#### Elevation-Capacity-Discharge Table

Elevation	Area (ac)	Capacity (ac-ft)	Discharge (cfs)	Dewater Time (hrs)
798.00	0.000	0.000	0.000	Top of Sed. Storage
798.01	0.001	0.000	0.000	Low hole SPW #1
798.50	0.126	0.023	0.368	0.74*
799.00	0.464	0.161	0.523	3.21*
799.50	0.486	0.399	0.641	4.48*
800.00	0.508	0.647	0.741	4.06*
800.50	0.531	0.907	0.829	3.79*

Elevation	Area (ac)	Capacity (ac-ft)	Discharge (cfs)	Dewater Time (hrs)
801.00	0.554	1.178	0.908	3.80
801.50	0.578	1.461	0.981	3.60
802.00	0.602	1.756	1.049	3.55
802.50	0.626	2.063	1.113	3.40
803.00	0.651	2.383	1.173	3.40
803.50	0.676	2.714	1.231	3.35
803.91	0.697	2.997	1.276	7.30 Peak Stage
804.00	0.702	3.059	1.285	Spillway #1
804.50	0.728	3.417	9.754	
805.00	0.754	3.787	9.995	Spillway #2
805.50	0.781	4.171	17.462	
806.00	0.809	4.568	105.988	
806.50	0.836	4.979	205.839	

*\*Designates time(s) to dewater have been extrapolated beyond the 50 hour hydrograph limit.*

**Detailed Discharge Table**

Elevation (ft)	Perf. Riser (cfs)	Emergency Spillway (cfs)	Combined Total Discharge (cfs)
798.00	0.000	0.000	0.000
798.01	2.00	0.000	0.000
798.50	0.368	0.000	0.368
799.00	0.523	0.000	0.523
799.50	0.641	0.000	0.641
800.00	0.741	0.000	0.741
800.50	0.829	0.000	0.829
801.00	0.908	0.000	0.908
801.50	0.981	0.000	0.981
802.00	1.049	0.000	1.049
802.50	1.113	0.000	1.113
803.00	1.173	0.000	1.173
803.50	1.231	0.000	1.231
804.00	1.285	0.000	1.285
804.50	9.754	0.000	9.754
805.00	9.995	0.000	9.995
805.50	10.230	7.232	17.462
806.00	10.460	95.528	105.988
806.50	10.685	195.154	205.839

**Subwatershed Hydrology Detail:**

Stru #	SWS #	SWS Area (ac)	Time of Conc (hrs)	Musk K (hrs)	Musk X	Curve Number	UHS	Peak Discharge (cfs)	Runoff Volume (ac-ft)
#1	1	13.000	0.114	0.114	0.326	86.000	M	48.58	4.261
<b>Σ</b>		<b>13.000</b>						<b>47.40</b>	<b>4.261</b>

**Subwatershed Sedimentology Detail:**

Stru #	SWS #	Soil K	L (ft)	S (%)	C	P	PS #	Sediment (tons)	Peak Sediment Conc. (mg/l)	Peak Settleable Conc (ml/l)	24WW (ml/l)
#1	1	0.240	4.00	3.90	0.0500	1.0000	1	3.9	1,251	0.77	0.42
<b>Σ</b>								<b>3.9</b>	<b>1,233</b>	<b>0.75</b>	<b>0.41</b>

**Subwatershed Time of Concentration Details:**

Stru #	SWS #	Land Flow Condition	Slope (%)	Vert. Dist. (ft)	Horiz. Dist. (ft)	Velocity (fps)	Time (hrs)
#1	1	3. Short grass pasture	33.00	12.00	36.36	4.590	0.002
		3. Short grass pasture	12.00	2.00	16.66	2.770	0.001
		3. Short grass pasture	33.00	26.00	78.78	4.590	0.004
		6. Grassed waterway	4.14	48.68	1,176.00	3.050	0.107
<b>#1</b>	<b>1</b>	<b>Time of Concentration:</b>					<b>0.114</b>

**Subwatershed Muskingum Routing Details:**

Stru #	SWS #	Land Flow Condition	Slope (%)	Vert. Dist. (ft)	Horiz. Dist. (ft)	Velocity (fps)	Time (hrs)
#1	1	3. Short grass pasture	33.00	12.00	36.36	4.590	0.002
		3. Short grass pasture	12.00	2.00	16.66	2.770	0.001
		3. Short grass pasture	33.00	26.00	78.78	4.590	0.004
		6. Grassed waterway	4.14	48.68	1,176.00	3.050	0.107
<b>#1</b>	<b>1</b>	<b>Muskingum K:</b>					<b>0.114</b>

# Inflow/Outflow Hydrographs for Structure # 1

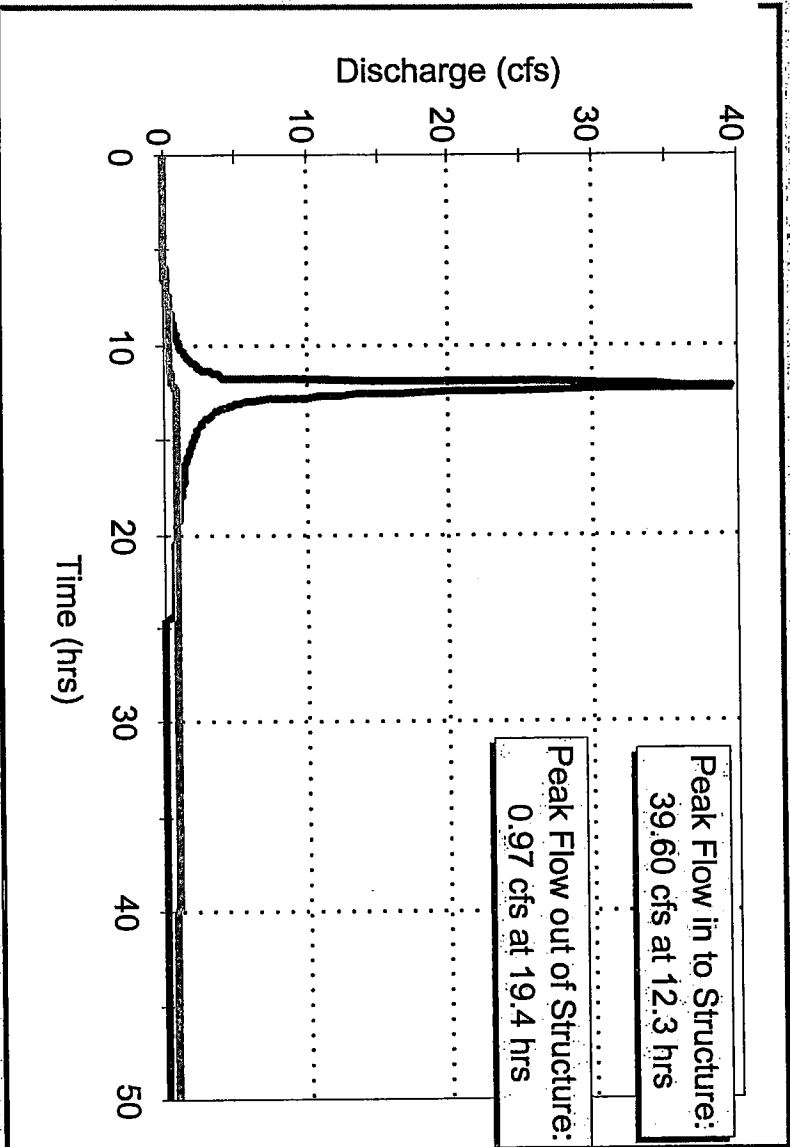

Peak Flow in to Structure:  
39.60 cfs at 12.3 hrs

Peak Flow out of Structure:  
0.97 cfs at 19.4 hrs

— Inflow  
- - - Outflow

**RECEIVED**

MAY 9 2008

DIVISION OF MINING &  
SOLID WASTE MANAGEMENT  
B-111

**Pond 2 25yr**

Davis & Floyd, Inc.  
1319 Hwy 72 221 E.  
Greenwood, SC 29649

Phone: 864-229-5211

## ***General Information***

### ***Storm Information:***

Storm Type:	NRCS Type II
Design Storm:	25 yr - 24 hr
Rainfall Depth:	6.600 inches

### ***Particle Size Distribution:***

Size (mm)	Madison
1.4000	100.000%
1.0000	84.600%
0.0630	49.300%
0.0440	42.600%
0.0380	42.600%
0.0040	8.800%
0.0030	5.800%
0.0010	0.000%



**Structure Networking:**

Type	Stru #	(flows into)	Stru #	Musk. K (hrs)	Musk. X	Description
Pond	#1	==>	End	0.000	0.000	

#1  
Pond

***Structure Summary:***

		Immediate Contributing Area (ac)	Total Contributing Area (ac)	Peak Discharge (cfs)	Total Runoff Volume (ac-ft)	Sediment (tons)	Peak Sediment Conc. (mg/l)	Peak Settleable Conc. (ml/l)	24VW (ml/l)
#1	In	13.000	13.000	58.83	5.39	5.0	1,251	0.76	0.42
	Out			5.79	4.65	0.5	275	0.02	0.01

***Particle Size Distribution(s) at Each Structure***

***Structure #1:***

Size (mm)	In	Out
1.4000	100.000%	100.000%
1.0000	85.853%	100.000%
0.0630	50.030%	100.000%
0.0440	43.231%	100.000%
0.0380	43.231%	100.000%
0.0040	8.930%	83.377%
0.0030	5.886%	54.953%
0.0010	0.000%	0.000%

**Structure Detail:**

Structure #1 (Pond)

Pond Inputs:

Initial Pool Elev:	798.01 ft
Initial Pool:	0.00 ac-ft
*Sediment Storage:	0.00 ac-ft
Dead Space:	20.00 %

*\*No sediment capacity defined*

Perforated Riser

Riser Diameter (in)	Riser Height (ft)	Barrel Diameter (in)	Barrel Length (ft)	Barrel Slope (%)	Manning's n	Spillway Elev (ft)	Number of Holes per Elev
48.00	8.00	18.00	300.00	0.50	0.0240	804.00	5

Emergency Spillway

Spillway Elev	Crest Length (ft)	Left Sideslope	Right Sideslope	Bottom Width (ft)
805.00	20.00	3.00:1	3.00:1	40.00

Pond Results:

Peak Elevation:	804.27 ft
H'graph Detention Time:	12.19 hrs
Pond Model:	CSTRS
Dewater Time:	2.11 days
Trap Efficiency:	89.29 %

*Dewatering time is calculated from peak stage to lowest spillway*

Elevation-Capacity-Discharge Table

Elevation	Area (ac)	Capacity (ac-ft)	Discharge (cfs)	Dewater Time (hrs)
798.00	0.000	0.000	0.000	Top of Sed. Storage
798.01	0.001	0.000	0.000	Low hole SPW #1
798.50	0.126	0.023	0.368	0.74*
799.00	0.464	0.161	0.523	3.21*
799.50	0.486	0.399	0.641	4.48*
800.00	0.508	0.647	0.741	4.06*
800.50	0.531	0.907	0.829	3.79*

# SEDCAD 4 for Windows

Copyright 1998-2002 Pamela J. Schwab

Elevation	Area (ac)	Capacity (ac-ft)	Discharge (cfs)	Dewater Time (hrs)
801.00	0.554	1.178	0.908	3.80
801.50	0.578	1.461	0.981	3.60
802.00	0.602	1.756	1.049	3.50
802.50	0.626	2.063	1.113	3.45
803.00	0.651	2.383	1.173	3.40
803.50	0.676	2.714	1.231	3.35
804.00	0.702	3.059	1.285	7.05 Spillway #1
804.27	0.716	3.249	5.793	6.25 Peak Stage
804.50	0.728	3.417	9.754	
805.00	0.754	3.787	9.995	Spillway #2
805.50	0.781	4.171	17.462	
806.00	0.809	4.568	105.988	
806.50	0.836	4.979	205.839	

*\*Designates time(s) to dewater have been extrapolated beyond the 50 hour hydrograph limit.*

## Detailed Discharge Table

Elevation (ft)	Perf. Riser (cfs)	Emergency Spillway (cfs)	Combined Total Discharge (cfs)
798.00	0.000	0.000	0.000
798.01	2.00	0.000	0.000
798.50	0.368	0.000	0.368
799.00	0.523	0.000	0.523
799.50	0.641	0.000	0.641
800.00	0.741	0.000	0.741
800.50	0.829	0.000	0.829
801.00	0.908	0.000	0.908
801.50	0.981	0.000	0.981
802.00	1.049	0.000	1.049
802.50	1.113	0.000	1.113
803.00	1.173	0.000	1.173
803.50	1.231	0.000	1.231
804.00	1.285	0.000	1.285
804.50	9.754	0.000	9.754
805.00	9.995	0.000	9.995
805.50	10.230	7.232	17.462
806.00	10.460	95.528	105.988
806.50	10.685	195.154	205.839

**Subwatershed Hydrology Detail:**

Stru #	SWS #	SWS Area (ac)	Time of Conc (hrs)	Musk K (hrs)	Musk X	Curve Number	UHS	Peak Discharge (cfs)	Runoff Volume (ac-ft)
#1	1	13.000	0.114	0.114	0.326	86.000	M	60.07	5.393
<b>Σ</b>		<b>13.000</b>						<b>58.83</b>	<b>5.393</b>

**Subwatershed Sedimentology Detail:**

Stru #	SWS #	Soil K	L (ft)	S (%)	C	P	PS #	Sediment (tons)	Peak Sediment Conc. (mg/l)	Peak Settleable Conc. (ml/l)	24VW (ml/l)
#1	1	0.240	4.00	3.90	0.0500	1.0000	1	5.1	1,269	0.78	0.42
<b>Σ</b>								<b>5.0</b>	<b>1,251</b>	<b>0.76</b>	<b>0.42</b>

**Subwatershed Time of Concentration Details:**

Stru #	SWS #	Land Flow Condition	Slope (%)	Vert. Dist. (ft)	Horiz. Dist. (ft)	Velocity (fps)	Time (hrs)
#1	1	3. Short grass pasture	33.00	12.00	36.36	4.590	0.002
		3. Short grass pasture	12.00	2.00	16.66	2.770	0.001
		3. Short grass pasture	33.00	26.00	78.78	4.590	0.004
		6. Grassed waterway	4.14	48.68	1,176.00	3.050	0.107
#1	1	<b>Time of Concentration:</b>					<b>0.114</b>

**Subwatershed Muskingum Routing Details:**

Stru #	SWS #	Land Flow Condition	Slope (%)	Vert. Dist. (ft)	Horiz. Dist. (ft)	Velocity (fps)	Time (hrs)
#1	1	3. Short grass pasture	33.00	12.00	36.36	4.590	0.002
		3. Short grass pasture	12.00	2.00	16.66	2.770	0.001
		3. Short grass pasture	33.00	26.00	78.78	4.590	0.004
		6. Grassed waterway	4.14	48.68	1,176.00	3.050	0.107
#1	1	<b>Muskingum K:</b>					<b>0.114</b>

# Inflow/Outflow Hydrographs for Structure # 1

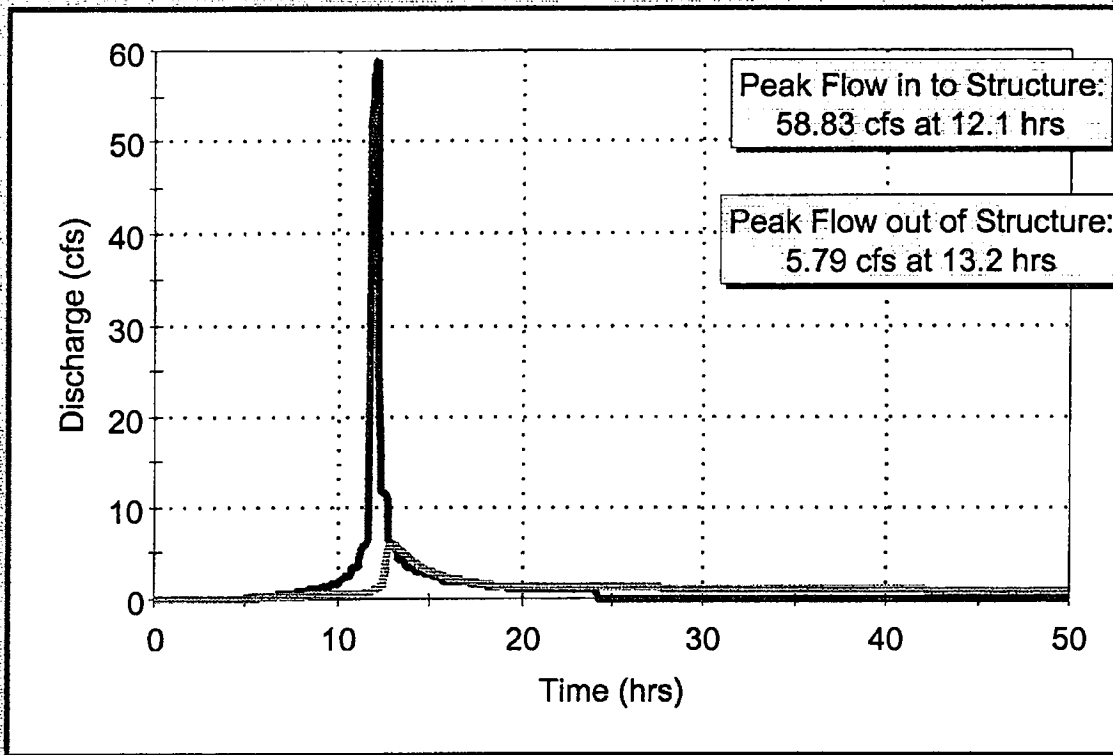

Peak Flow in to Structure:  
58.83 cfs at 12.1 hrs

Peak Flow out of Structure:  
5.79 cfs at 13.2 hrs

— Inflow  
- - - Outflow

Type.... 1st Flush  
Name.... BMP1ST 1

File.... H:\JOBSODD\11967-00\C\Ponds\New Design\Pond 13 ac.ppw

---

BMP FIRST FLUSH CALCULATIONS

First Flush Depth = 1.0000 in  
Drainage Area = 13.000 acres

Volume = Flush Depth \* Drainage Area

-----  
First Flush volume = 1.083 ac-ft  
-----



File.... H:\JOBSODD\11967-00\C\Ponds\New Design\Pond 13 ac.ppw

---

TIME vs. VOLUME (ac-ft)

Output Time increment = .5000 hrs  
Time on left represents time for first value in each row.

Time hrs					
.0000	1.089	1.055	1.023	.992	.962
2.5000	.933	.905	.877	.849	.821
5.0000	.793	.765	.737	.710	.682
7.5000	.655	.627	.599	.572	.546
10.0000	.520	.495	.471	.447	.423
12.5000	.400	.378	.355	.332	.310
15.0000	.289	.268	.247	.226	.206
17.5000	.187	.168	.145	.117	.095
20.0000	.078	.064	.052	.043	.036
22.5000	.030	.025	.021	.011	.003
25.0000	.001	.000	.000	.000	.000
27.5000	.000	.000	.000	.000	.000
30.0000	.000				

# Watershed Model Schematic

Hydraflow Hydrographs Extension for AutoCAD® Civil 3D® 2016 by Autodesk, Inc. v11



**Legend**

<u>Hyd.</u>	<u>Origin</u>	<u>Description</u>
1	SCS Runoff	DA 2.1

<b>Watershed Model Schematic.....</b>	<b>1</b>
<b>Hydrograph Return Period Recap.....</b>	<b>2</b>
<b>2 - Year</b>	
<b>Summary Report.....</b>	<b>3</b>
<b>Hydrograph Reports.....</b>	<b>4</b>
Hydrograph No. 1, SCS Runoff, DA 2.1.....	4
TR-55 Tc Worksheet.....	5
<b>10 - Year</b>	
<b>Summary Report.....</b>	<b>6</b>
<b>Hydrograph Reports.....</b>	<b>7</b>
Hydrograph No. 1, SCS Runoff, DA 2.1.....	7
<b>25 - Year</b>	
<b>Summary Report.....</b>	<b>8</b>
<b>Hydrograph Reports.....</b>	<b>9</b>
Hydrograph No. 1, SCS Runoff, DA 2.1.....	9
<b>100 - Year</b>	
<b>Summary Report.....</b>	<b>10</b>
<b>Hydrograph Reports.....</b>	<b>11</b>
Hydrograph No. 1, SCS Runoff, DA 2.1.....	11
<b>IDF Report.....</b>	<b>12</b>

# Hydrograph Return Period Recap

Hydraflow Hydrographs Extension for AutoCAD® Civil 3D® 2016 by Autodesk, Inc. v11

Hyd. No.	Hydrograph type (origin)	Inflow hyd(s)	Peak Outflow (cfs)								Hydrograph Description
			1-yr	2-yr	3-yr	5-yr	10-yr	25-yr	50-yr	100-yr	
1	SCS Runoff	-----	-----	11.91	-----	-----	53.17	83.76	-----	172.88	DA 2.1

# Hydrograph Summary Report

Hydraflow Hydrographs Extension for AutoCAD® Civil 3D® 2016 by Autodesk, Inc. v11

Hyd. No.	Hydrograph type (origin)	Peak flow (cfs)	Time interval (min)	Time to Peak (min)	Hyd. volume (cuft)	Inflow hyd(s)	Maximum elevation (ft)	Total strge used (cuft)	Hydrograph Description
1	SCS Runoff	11.91	2	730	68,354	-----	-----	-----	DA 2.1
Pre-Development Hydraflow Model.gpw					Return Period: 2 Year			Tuesday, 04 / 17 / 2018	

# Hydrograph Report

## Hyd. No. 1

DA 2.1

Hydrograph type	= SCS Runoff	Peak discharge	= 11.91 cfs
Storm frequency	= 2 yrs	Time to peak	= 730 min
Time interval	= 2 min	Hyd. volume	= 68,354 cuft
Drainage area	= 40.780 ac	Curve number	= 57
Basin Slope	= 0.0 %	Hydraulic length	= 0 ft
Tc method	= TR55	Time of conc. (Tc)	= 20.70 min
Total precip.	= 3.60 in	Distribution	= Type II
Storm duration	= 24 hrs	Shape factor	= 484

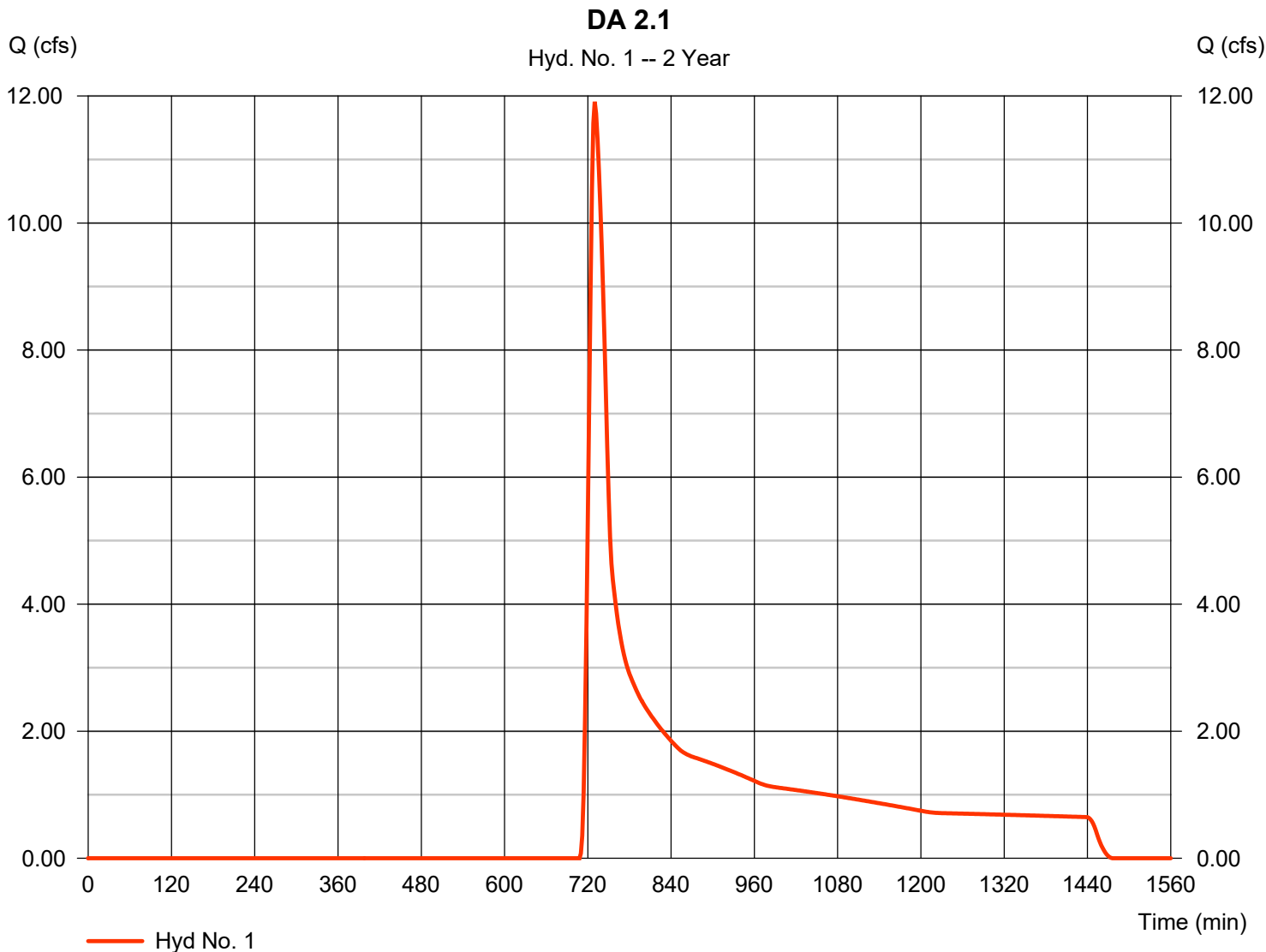

# TR55 Tc Worksheet

Hydraflow Hydrographs Extension for AutoCAD® Civil 3D® 2016 by Autodesk, Inc. v11

## Hyd. No. 1

DA 2.1

<u>Description</u>	<u>A</u>	<u>B</u>	<u>C</u>	<u>Totals</u>
<b>Sheet Flow</b>				
Manning's n-value	= 0.400	0.011	0.011	
Flow length (ft)	= 100.0	0.0	0.0	
Two-year 24-hr precip. (in)	= 3.60	0.00	0.00	
Land slope (%)	= 6.00	0.00	0.00	
<b>Travel Time (min)</b>	<b>= 13.05</b>	<b>+ 0.00</b>	<b>+ 0.00</b>	<b>= 13.05</b>
<b>Shallow Concentrated Flow</b>				
Flow length (ft)	= 1358.68	0.00	0.00	
Watercourse slope (%)	= 3.40	0.00	0.00	
Surface description	= Unpaved	Paved	Paved	
Average velocity (ft/s)	=2.98	0.00	0.00	
<b>Travel Time (min)</b>	<b>= 7.61</b>	<b>+ 0.00</b>	<b>+ 0.00</b>	<b>= 7.61</b>
<b>Channel Flow</b>				
X sectional flow area (sqft)	= 0.00	0.00	0.00	
Wetted perimeter (ft)	= 0.00	0.00	0.00	
Channel slope (%)	= 0.00	0.00	0.00	
Manning's n-value	= 0.015	0.015	0.015	
Velocity (ft/s)	=0.00	0.00	0.00	
Flow length (ft)	({0})0.0	0.0	0.0	
<b>Travel Time (min)</b>	<b>= 0.00</b>	<b>+ 0.00</b>	<b>+ 0.00</b>	<b>= 0.00</b>
<b>Total Travel Time, Tc .....</b>				<b>20.70 min</b>

# Hydrograph Summary Report

Hydraflow Hydrographs Extension for AutoCAD® Civil 3D® 2016 by Autodesk, Inc. v11

Hyd. No.	Hydrograph type (origin)	Peak flow (cfs)	Time interval (min)	Time to Peak (min)	Hyd. volume (cuft)	Inflow hyd(s)	Maximum elevation (ft)	Total strge used (cuft)	Hydrograph Description
1	SCS Runoff	53.17	2	728	208,081	-----	-----	-----	DA 2.1
Pre-Development Hydraflow Model.gpw					Return Period: 10 Year			Tuesday, 04 / 17 / 2018	



# Hydrograph Report

Hydraflow Hydrographs Extension for AutoCAD® Civil 3D® 2016 by Autodesk, Inc. v11

Tuesday, 04 / 17 / 2018

## Hyd. No. 1

DA 2.1

Hydrograph type	= SCS Runoff	Peak discharge	= 53.17 cfs
Storm frequency	= 10 yrs	Time to peak	= 728 min
Time interval	= 2 min	Hyd. volume	= 208,081 cuft
Drainage area	= 40.780 ac	Curve number	= 57
Basin Slope	= 0.0 %	Hydraulic length	= 0 ft
Tc method	= TR55	Time of conc. (Tc)	= 20.70 min
Total precip.	= 5.50 in	Distribution	= Type II
Storm duration	= 24 hrs	Shape factor	= 484

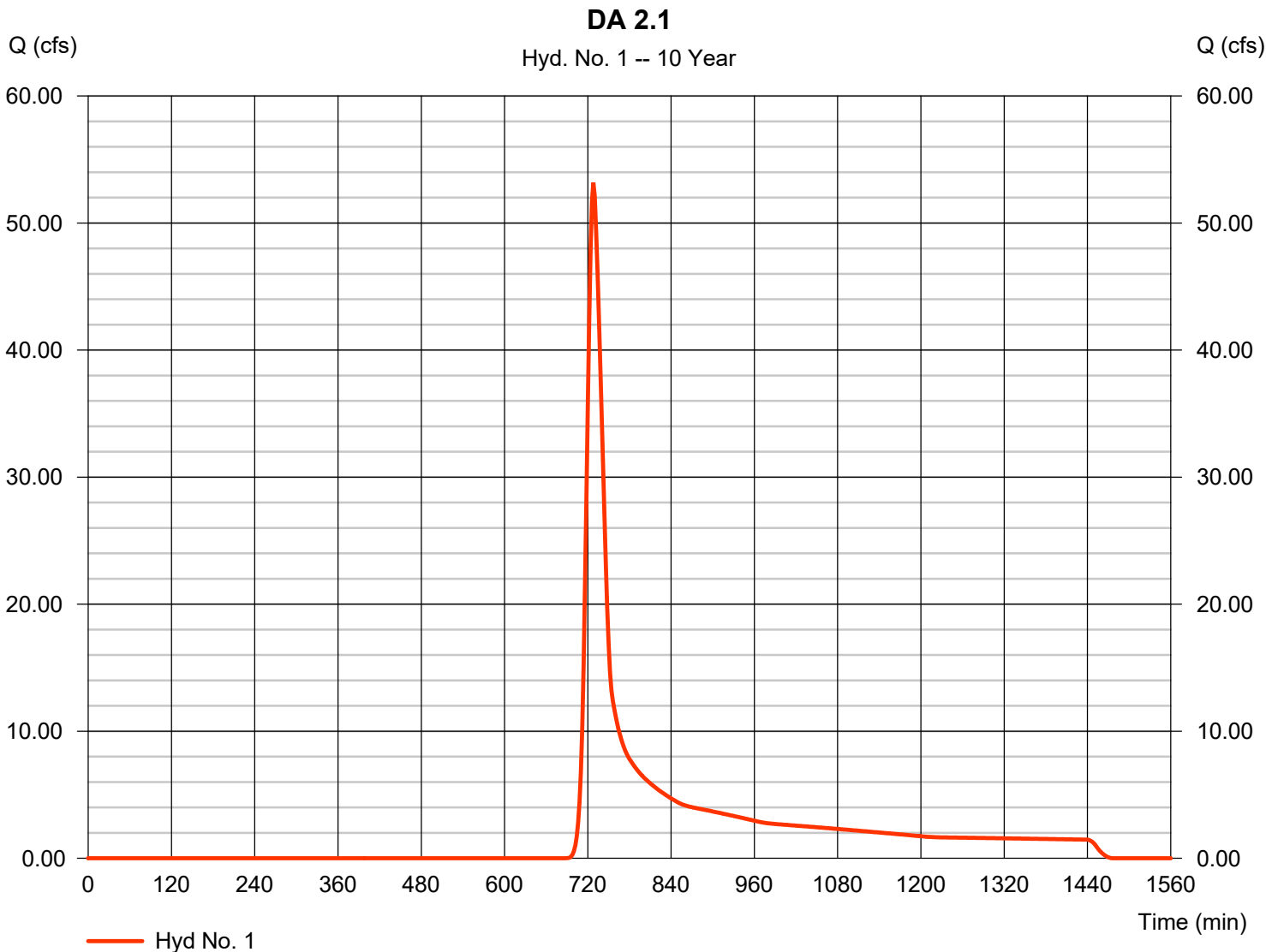

# Hydrograph Summary Report

Hydraflow Hydrographs Extension for AutoCAD® Civil 3D® 2016 by Autodesk, Inc. v11

Hyd. No.	Hydrograph type (origin)	Peak flow (cfs)	Time interval (min)	Time to Peak (min)	Hyd. volume (cuft)	Inflow hyd(s)	Maximum elevation (ft)	Total strge used (cuft)	Hydrograph Description
1	SCS Runoff	83.76	2	728	309,106	-----	-----	-----	DA 2.1
Pre-Development Hydraflow Model.gpw					Return Period: 25 Year			Tuesday, 04 / 17 / 2018	

# Hydrograph Report

## Hyd. No. 1

DA 2.1

Hydrograph type	= SCS Runoff	Peak discharge	= 83.76 cfs
Storm frequency	= 25 yrs	Time to peak	= 728 min
Time interval	= 2 min	Hyd. volume	= 309,106 cuft
Drainage area	= 40.780 ac	Curve number	= 57
Basin Slope	= 0.0 %	Hydraulic length	= 0 ft
Tc method	= TR55	Time of conc. (Tc)	= 20.70 min
Total precip.	= 6.60 in	Distribution	= Type II
Storm duration	= 24 hrs	Shape factor	= 484

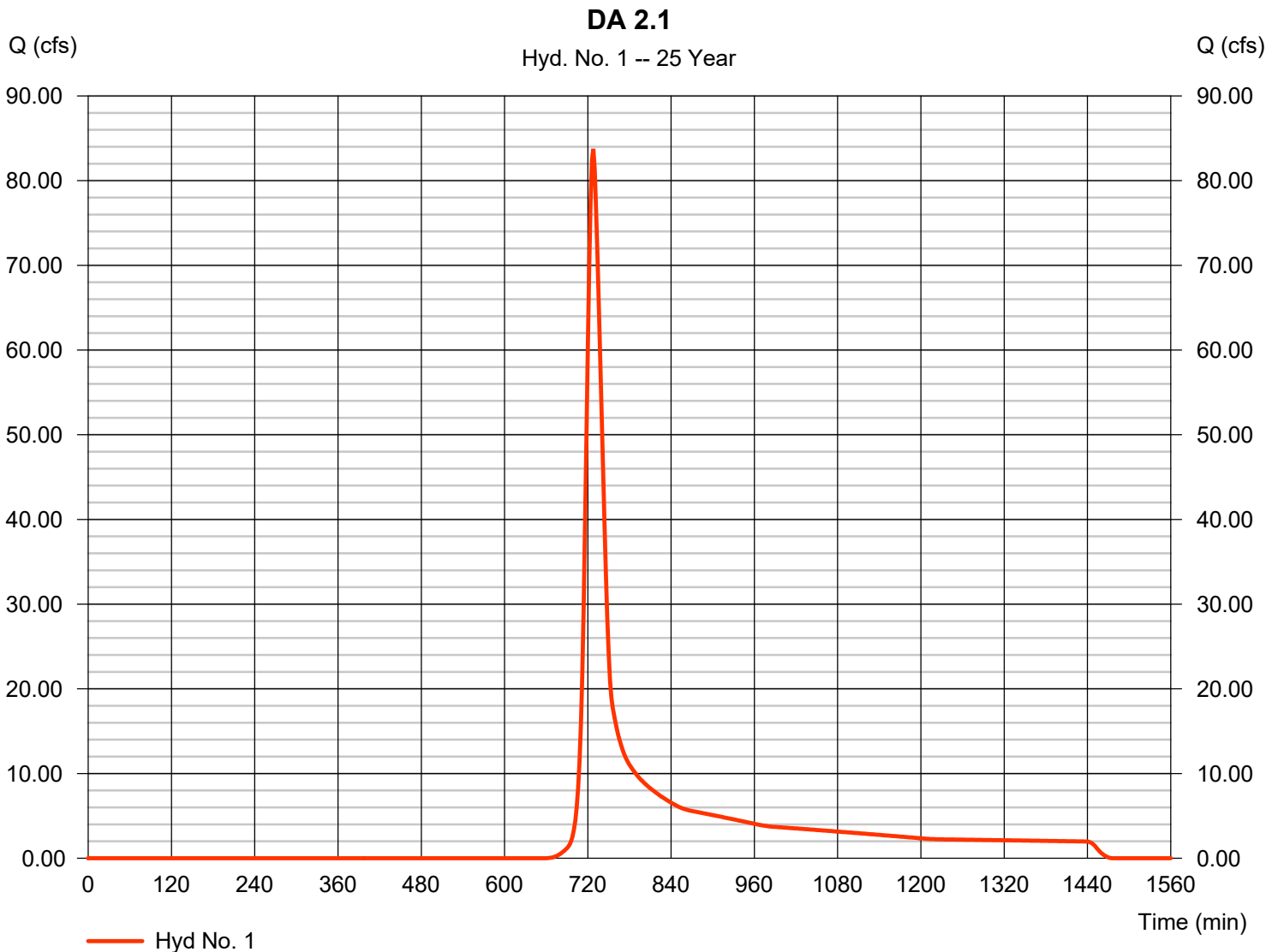

# Hydrograph Summary Report

Hydraflow Hydrographs Extension for AutoCAD® Civil 3D® 2016 by Autodesk, Inc. v11

Hyd. No.	Hydrograph type (origin)	Peak flow (cfs)	Time interval (min)	Time to Peak (min)	Hyd. volume (cuft)	Inflow hyd(s)	Maximum elevation (ft)	Total strge used (cuft)	Hydrograph Description
1	SCS Runoff	172.88	2	728	607,884	-----	-----	-----	DA 2.1
Pre-Development Hydraflow Model.gpw					Return Period: 100 Year			Tuesday, 04 / 17 / 2018	

# Hydrograph Report

Hydraflow Hydrographs Extension for AutoCAD® Civil 3D® 2016 by Autodesk, Inc. v11

Tuesday, 04 / 17 / 2018

## Hyd. No. 1

DA 2.1

Hydrograph type = SCS Runoff  
 Storm frequency = 100 yrs  
 Time interval = 2 min  
 Drainage area = 40.780 ac  
 Basin Slope = 0.0 %  
 Tc method = TR55  
 Total precip. = 9.40 in  
 Storm duration = 24 hrs

Peak discharge = 172.88 cfs  
 Time to peak = 728 min  
 Hyd. volume = 607,884 cuft  
 Curve number = 57  
 Hydraulic length = 0 ft  
 Time of conc. (Tc) = 20.70 min  
 Distribution = Type II  
 Shape factor = 484

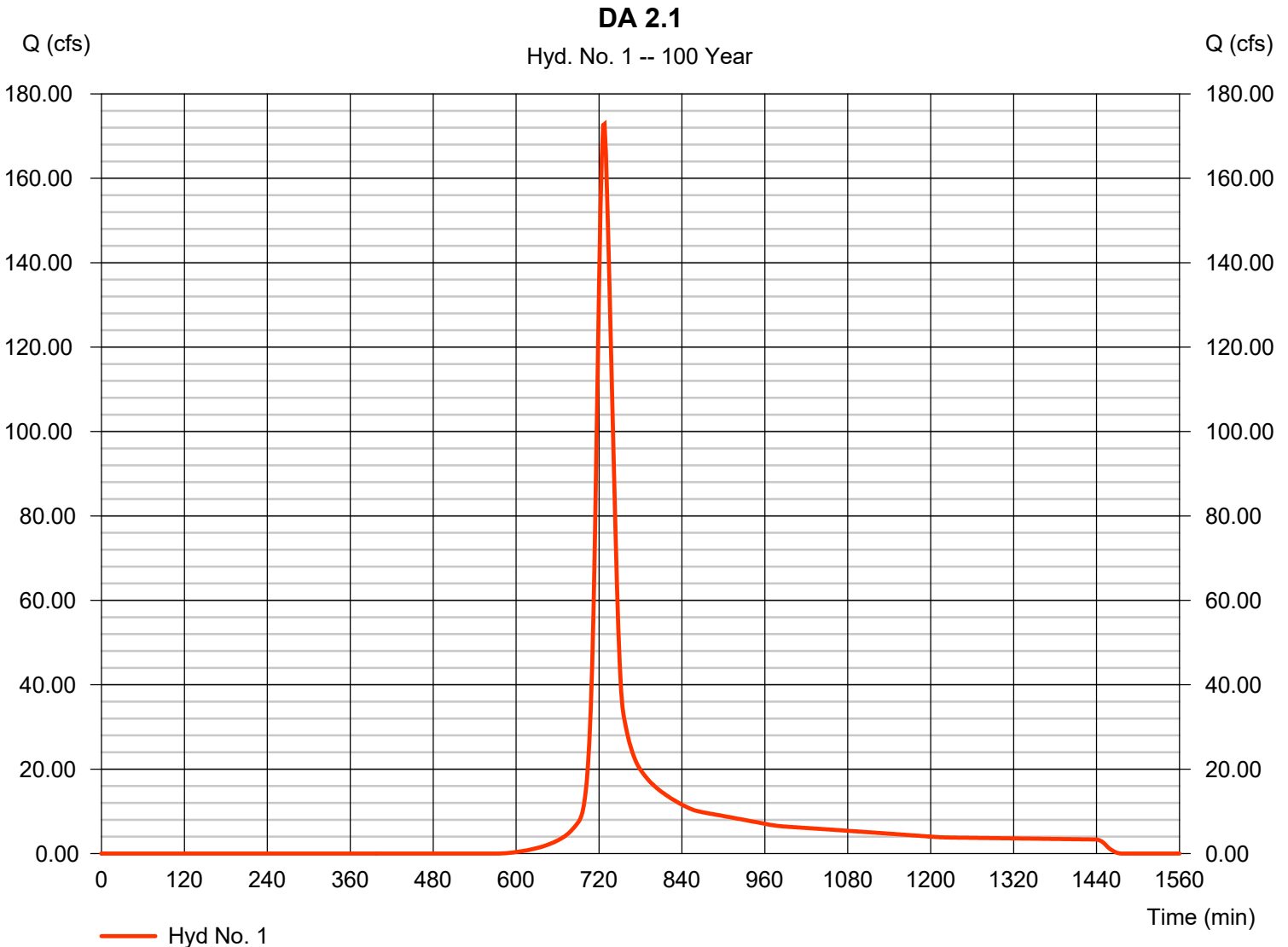



**APPENDIX D      Post-Development – HydroCAD**

# Watershed Model Schematic

Hydraflow Hydrographs Extension for AutoCAD® Civil 3D® 2016 by Autodesk, Inc. v11

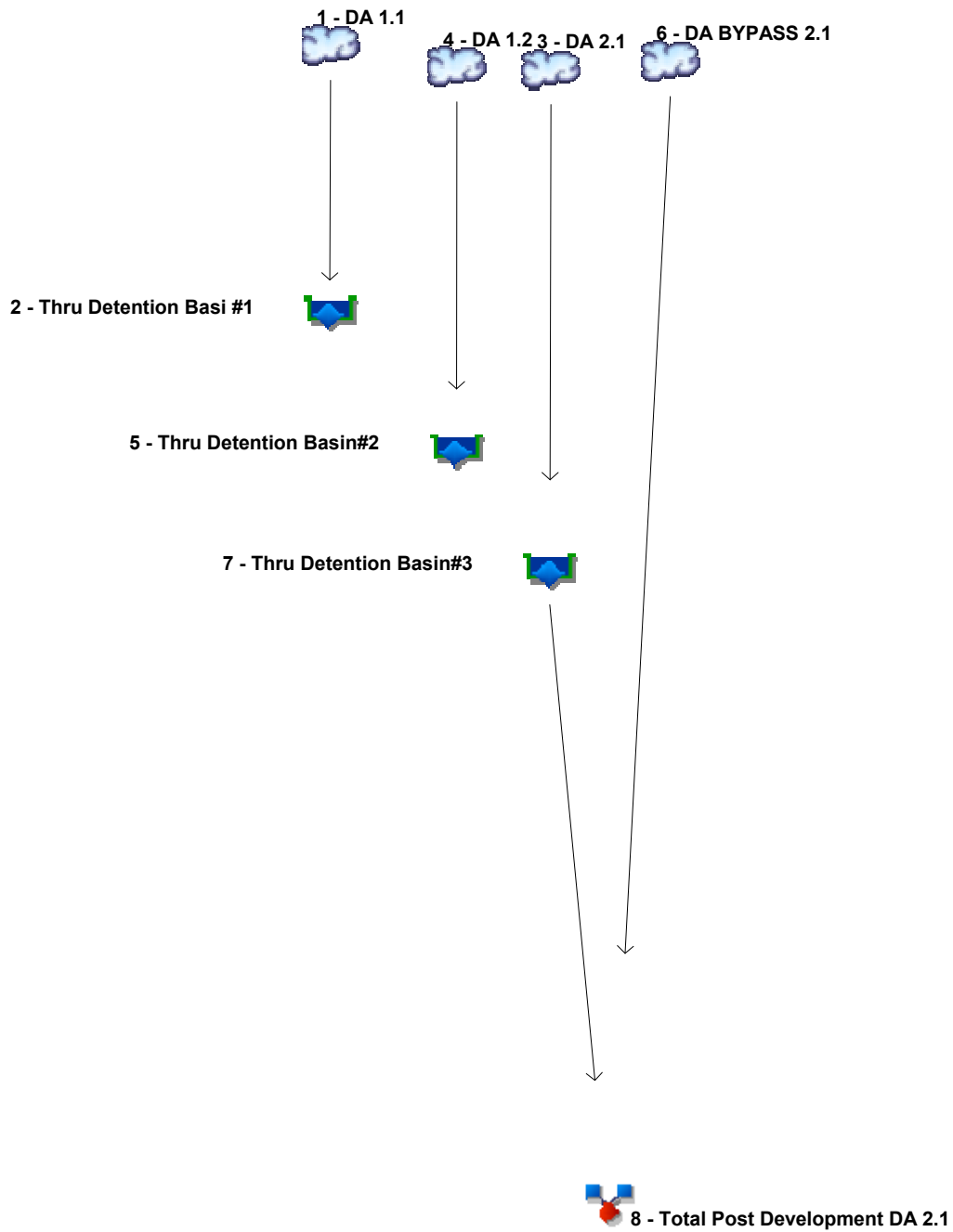

## Legend

Hyd.	Origin	Description
1	SCS Runoff	DA 1.1
2	Reservoir	Thru Detention Basi #1
3	SCS Runoff	DA 2.1
4	SCS Runoff	DA 1.2
5	Reservoir	Thru Detention Basin#2
6	SCS Runoff	DA BYPASS 2.1
7	Reservoir	Thru Detention Basin#3
8	Combine	Total Post Development DA 2.1



<b>Watershed Model Schematic.....</b>	<b>1</b>
<b>Hydrograph Return Period Recap.....</b>	<b>2</b>
<b>2 - Year</b>	
<b>Summary Report.....</b>	<b>3</b>
<b>Hydrograph Reports.....</b>	<b>4</b>
Hydrograph No. 1, SCS Runoff, DA 1.1.....	4
Hydrograph No. 2, Reservoir, Thru Detention Basi #1.....	5
Pond Report - Detention Basin #1.....	6
Hydrograph No. 3, SCS Runoff, DA 2.1.....	7
Hydrograph No. 4, SCS Runoff, DA 1.2.....	8
Hydrograph No. 5, Reservoir, Thru Detention Basin#2.....	9
Pond Report - Detention Basin #2.....	10
Hydrograph No. 6, SCS Runoff, DA BYPASS 2.1.....	11
TR-55 Tc Worksheet.....	12
Hydrograph No. 7, Reservoir, Thru Detention Basin#3.....	13
Pond Report - Detention Basin #3.....	14
Hydrograph No. 8, Combine, Total Post Development DA 2.1.....	15
<b>10 - Year</b>	
<b>Summary Report.....</b>	<b>16</b>
<b>Hydrograph Reports.....</b>	<b>17</b>
Hydrograph No. 1, SCS Runoff, DA 1.1.....	17
Hydrograph No. 2, Reservoir, Thru Detention Basi #1.....	18
Hydrograph No. 3, SCS Runoff, DA 2.1.....	19
Hydrograph No. 4, SCS Runoff, DA 1.2.....	20
Hydrograph No. 5, Reservoir, Thru Detention Basin#2.....	21
Hydrograph No. 6, SCS Runoff, DA BYPASS 2.1.....	22
Hydrograph No. 7, Reservoir, Thru Detention Basin#3.....	23
Hydrograph No. 8, Combine, Total Post Development DA 2.1.....	24
<b>25 - Year</b>	
<b>Summary Report.....</b>	<b>25</b>
<b>Hydrograph Reports.....</b>	<b>26</b>
Hydrograph No. 1, SCS Runoff, DA 1.1.....	26
Hydrograph No. 2, Reservoir, Thru Detention Basi #1.....	27
Hydrograph No. 3, SCS Runoff, DA 2.1.....	28
Hydrograph No. 4, SCS Runoff, DA 1.2.....	29
Hydrograph No. 5, Reservoir, Thru Detention Basin#2.....	30
Hydrograph No. 6, SCS Runoff, DA BYPASS 2.1.....	31
Hydrograph No. 7, Reservoir, Thru Detention Basin#3.....	32
Hydrograph No. 8, Combine, Total Post Development DA 2.1.....	33
<b>100 - Year</b>	
<b>Summary Report.....</b>	<b>34</b>
<b>Hydrograph Reports.....</b>	<b>35</b>
Hydrograph No. 1, SCS Runoff, DA 1.1.....	35

---

Hydrograph No. 2, Reservoir, Thru Detention Basi #1.....	36
Hydrograph No. 3, SCS Runoff, DA 2.1.....	37
Hydrograph No. 4, SCS Runoff, DA 1.2.....	38
Hydrograph No. 5, Reservoir, Thru Detention Basin#2.....	39
Hydrograph No. 6, SCS Runoff, DA BYPASS 2.1.....	40
Hydrograph No. 7, Reservoir, Thru Detention Basin#3.....	41
Hydrograph No. 8, Combine, Total Post Development DA 2.1.....	42
<b>IDF Report.....</b>	<b>43</b>

# Hydrograph Return Period Recap

Hydraflow Hydrographs Extension for AutoCAD® Civil 3D® 2016 by Autodesk, Inc. v11

Hyd. No.	Hydrograph type (origin)	Inflow hyd(s)	Peak Outflow (cfs)								Hydrograph Description
			1-yr	2-yr	3-yr	5-yr	10-yr	25-yr	50-yr	100-yr	
1	SCS Runoff	-----	-----	63.15	-----	-----	110.65	138.14	-----	207.53	DA 1.1
2	Reservoir	1	-----	0.600	-----	-----	0.805	2.516	-----	41.97	Thru Detention Basi #1
3	SCS Runoff	-----	-----	82.22	-----	-----	146.12	183.24	-----	277.06	DA 2.1
4	SCS Runoff	-----	-----	100.56	-----	-----	176.19	219.96	-----	330.44	DA 1.2
5	Reservoir	4	-----	1.130	-----	-----	1.244	3.573	-----	37.53	Thru Detention Basin#2
6	SCS Runoff	-----	-----	9.445	-----	-----	31.88	47.26	-----	91.39	DA BYPASS 2.1
7	Reservoir	3	-----	2.258	-----	-----	16.40	32.33	-----	156.29	Thru Detention Basin#3
8	Combine	6, 7	-----	10.21	-----	-----	47.67	79.59	-----	243.67	Total Post Development DA 2.1

# Hydrograph Summary Report

Hydraflow Hydrographs Extension for AutoCAD® Civil 3D® 2016 by Autodesk, Inc. v11

Hyd. No.	Hydrograph type (origin)	Peak flow (cfs)	Time interval (min)	Time to Peak (min)	Hyd. volume (cuft)	Inflow hyd(s)	Maximum elevation (ft)	Total strge used (cuft)	Hydrograph Description	
1	SCS Runoff	63.15	2	716	129,060	-----	-----	-----	DA 1.1	
2	Reservoir	0.600	2	590	129,063	1	807.55	95,700	Thru Detention Basi #1	
3	SCS Runoff	82.22	2	716	167,383	-----	-----	-----	DA 2.1	
4	SCS Runoff	100.56	2	716	205,499	-----	-----	-----	DA 1.2	
5	Reservoir	1.130	2	604	205,511	4	802.63	145,351	Thru Detention Basin#2	
6	SCS Runoff	9.445	2	726	39,077	-----	-----	-----	DA BYPASS 2.1	
7	Reservoir	2.258	2	872	167,414	3	806.08	103,872	Thru Detention Basin#3	
8	Combine	10.21	2	726	206,490	6, 7	-----	-----	Total Post Development DA 2.1	
16227-Basin Design - 3 Ponds.gpw					Return Period: 2 Year			Thursday, 04 / 26 / 2018		

# Hydrograph Report

## Hyd. No. 1

DA 1.1

Hydrograph type	= SCS Runoff	Peak discharge	= 63.15 cfs
Storm frequency	= 2 yrs	Time to peak	= 716 min
Time interval	= 2 min	Hyd. volume	= 129,060 cuft
Drainage area	= 17.340 ac	Curve number	= 86
Basin Slope	= 0.0 %	Hydraulic length	= 0 ft
Tc method	= User	Time of conc. (Tc)	= 6.00 min
Total precip.	= 3.60 in	Distribution	= Type II
Storm duration	= 24 hrs	Shape factor	= 484

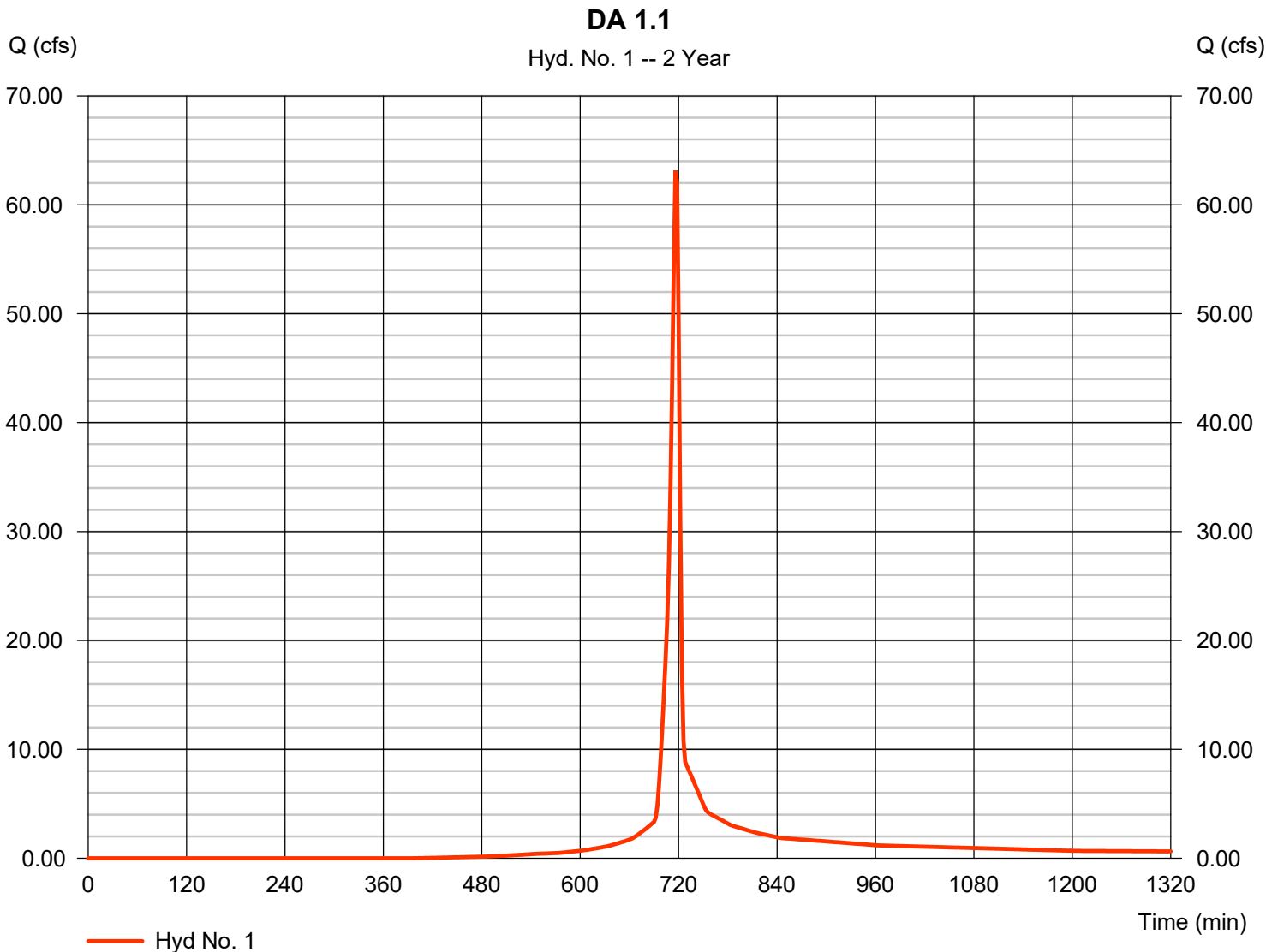

# Hydrograph Report

Hydraflow Hydrographs Extension for AutoCAD® Civil 3D® 2016 by Autodesk, Inc. v11

Thursday, 04 / 26 / 2018

## Hyd. No. 2

Thru Detention Basi #1

Hydrograph type	= Reservoir	Peak discharge	= 0.600 cfs
Storm frequency	= 2 yrs	Time to peak	= 590 min
Time interval	= 2 min	Hyd. volume	= 129,063 cuft
Inflow hyd. No.	= 1 - DA 1.1	Max. Elevation	= 807.55 ft
Reservoir name	= Detention Basin #1	Max. Storage	= 95,700 cuft

Storage Indication method used.

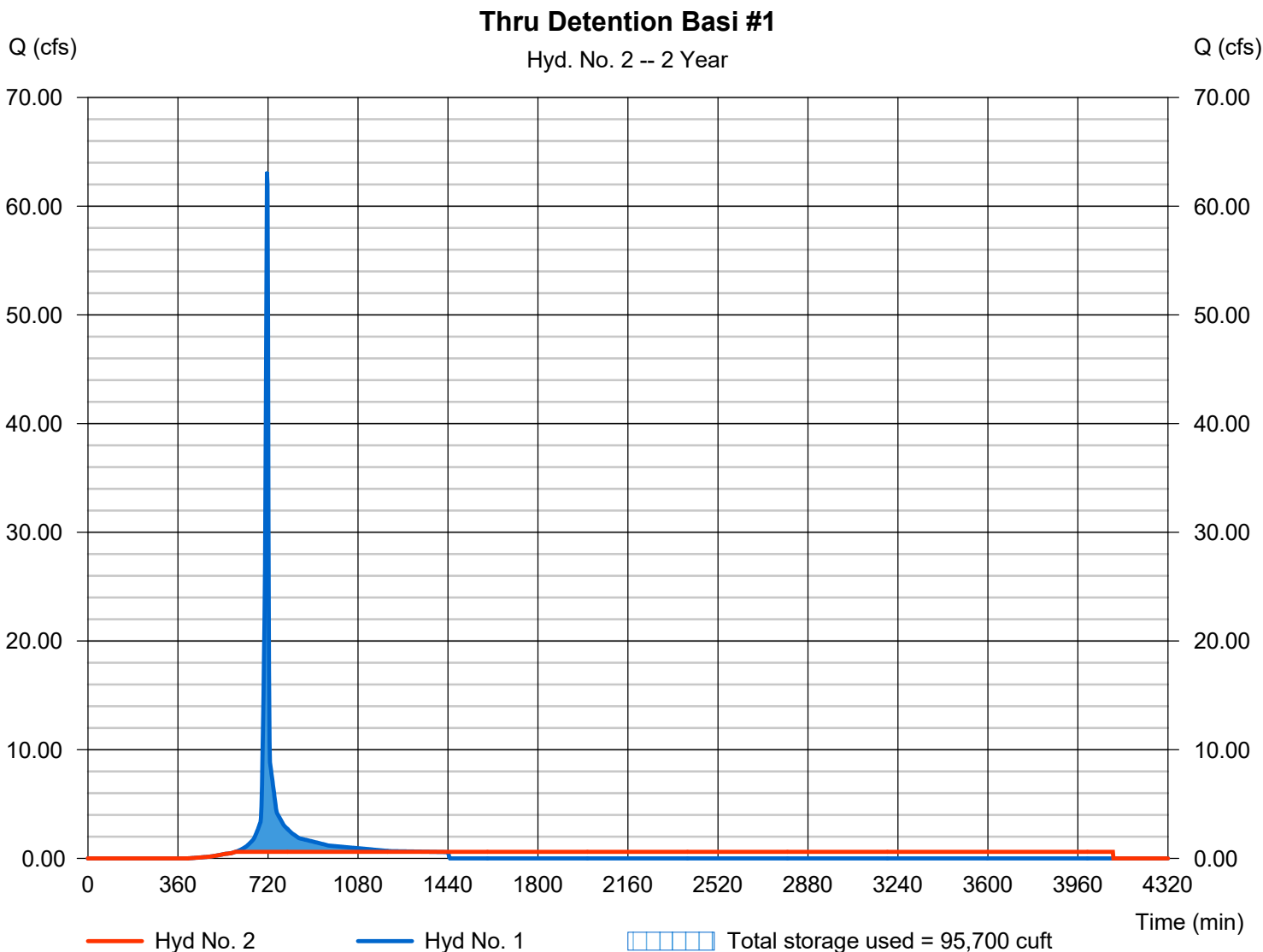

## Pond No. 1 - Detention Basin #1

### Pond Data

Contours -User-defined contour areas. Conic method used for volume calculation. Begining Elevation = 803.00 ft

### Stage / Storage Table

Stage (ft)	Elevation (ft)	Contour area (sqft)	Incr. Storage (cuft)	Total storage (cuft)
0.00	803.00	00	0	0
0.01	803.01	100	0	0
1.00	804.00	13,933	5,020	5,020
2.00	805.00	20,159	16,949	21,969
3.00	806.00	28,637	24,272	46,241
4.00	807.00	32,348	30,471	76,712
5.00	808.00	36,240	34,272	110,984
6.00	809.00	39,890	38,047	149,030
7.00	810.00	43,939	41,894	190,924
8.00	811.00	46,647	45,282	236,206
9.00	812.00	50,386	48,500	284,706
10.00	813.00	54,240	52,296	337,002
11.00	814.00	58,612	56,406	393,408
12.00	815.00	61,880	60,233	453,640

### Culvert / Orifice Structures

	[A]	[B]	[C]	[PrfRsr]
Rise (in)	= 24.00	0.00	0.00	0.00
Span (in)	= 24.00	0.00	0.00	0.00
No. Barrels	= 1	0	0	0
Invert El. (ft)	= 803.00	0.00	0.00	0.00
Length (ft)	= 100.00	0.00	0.00	0.00
Slope (%)	= 1.00	0.00	0.00	n/a
N-Value	= .013	.013	.013	n/a
Orifice Coeff.	= 0.60	0.60	0.60	0.60
Multi-Stage	= n/a	No	No	No

### Weir Structures

	[A]	[B]	[C]	[D]
Crest Len (ft)	= 14.50	24.00	1.50	0.00
Crest El. (ft)	= 810.50	811.00	809.92	0.00
Weir Coeff.	= 3.33	2.60	3.33	3.33
Weir Type	= 1	Broad	Rect	---
Multi-Stage	= Yes	No	Yes	No
Exfil.(in/hr)	= 0.000 (by Contour)			
TW Elev. (ft)	= 0.00			

Note: Culvert/Orifice outflows are analyzed under inlet (ic) and outlet (oc) control. Weir risers checked for orifice conditions (ic) and submergence (s).

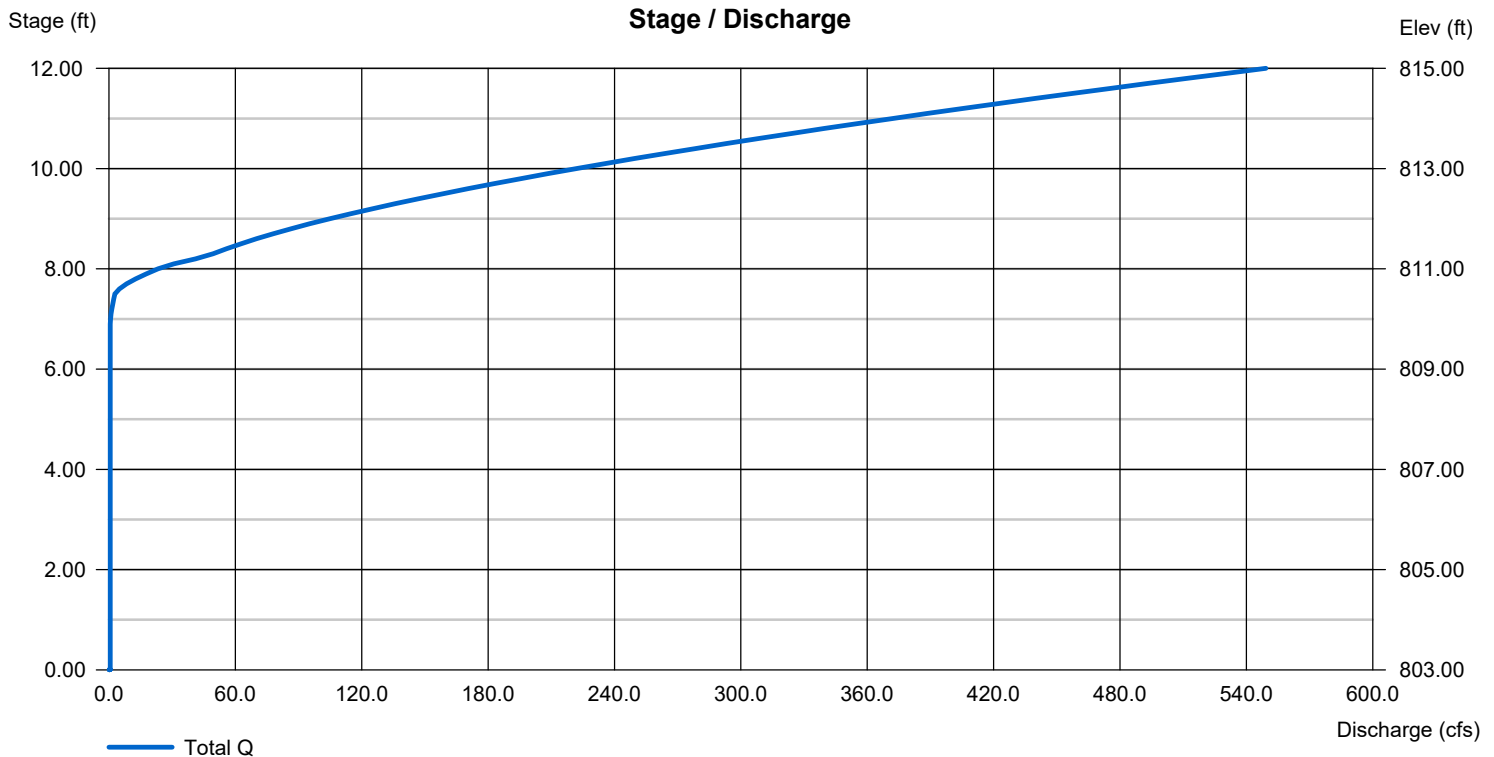

# Hydrograph Report

Hydraflow Hydrographs Extension for AutoCAD® Civil 3D® 2016 by Autodesk, Inc. v11

Thursday, 04 / 26 / 2018

## Hyd. No. 3

DA 2.1

Hydrograph type = SCS Runoff  
 Storm frequency = 2 yrs  
 Time interval = 2 min  
 Drainage area = 23.380 ac  
 Basin Slope = 0.0 %  
 Tc method = User  
 Total precip. = 3.60 in  
 Storm duration = 24 hrs

Peak discharge = 82.22 cfs  
 Time to peak = 716 min  
 Hyd. volume = 167,383 cuft  
 Curve number = 85  
 Hydraulic length = 0 ft  
 Time of conc. (Tc) = 6.00 min  
 Distribution = Type II  
 Shape factor = 484

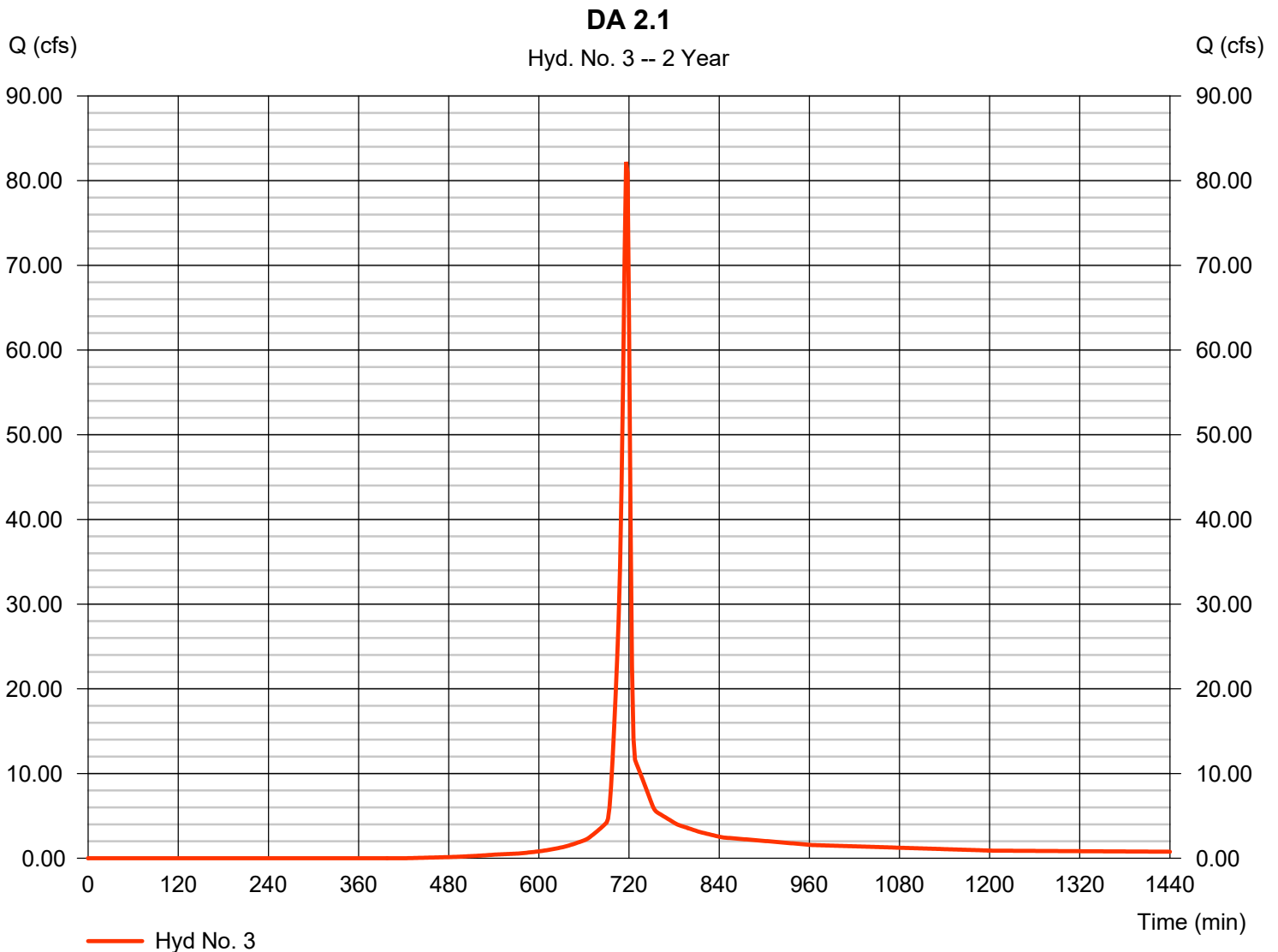



# Hydrograph Report

Hydraflow Hydrographs Extension for AutoCAD® Civil 3D® 2016 by Autodesk, Inc. v11

Thursday, 04 / 26 / 2018

## Hyd. No. 4

DA 1.2

Hydrograph type	= SCS Runoff	Peak discharge	= 100.56 cfs
Storm frequency	= 2 yrs	Time to peak	= 716 min
Time interval	= 2 min	Hyd. volume	= 205,499 cuft
Drainage area	= 27.610 ac	Curve number	= 86
Basin Slope	= 0.0 %	Hydraulic length	= 0 ft
Tc method	= User	Time of conc. (Tc)	= 6.00 min
Total precip.	= 3.60 in	Distribution	= Type II
Storm duration	= 24 hrs	Shape factor	= 484

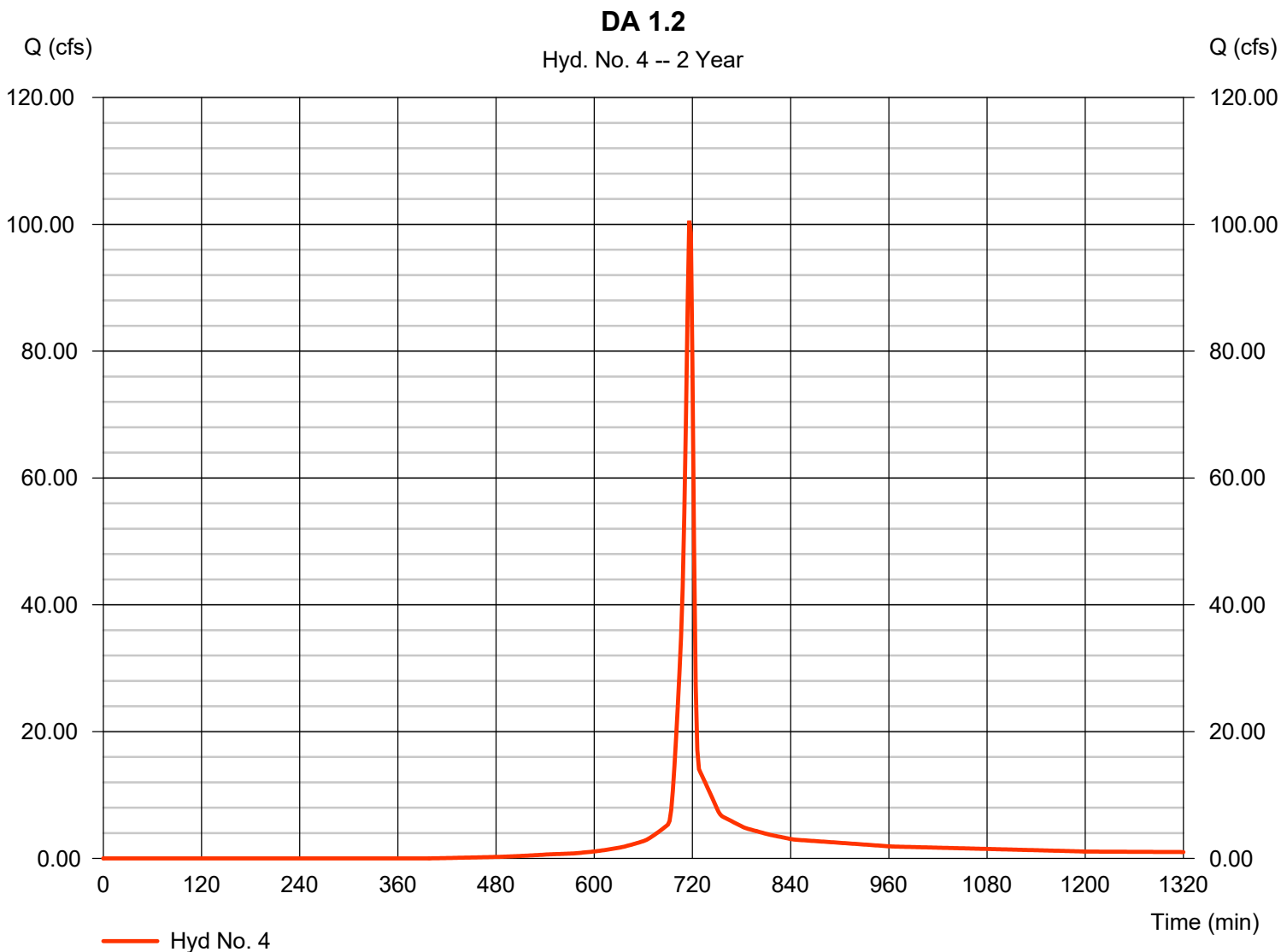

# Hydrograph Report

Hydraflow Hydrographs Extension for AutoCAD® Civil 3D® 2016 by Autodesk, Inc. v11

Thursday, 04 / 26 / 2018

## Hyd. No. 5

Thru Detention Basin#2

Hydrograph type	= Reservoir	Peak discharge	= 1.130 cfs
Storm frequency	= 2 yrs	Time to peak	= 604 min
Time interval	= 2 min	Hyd. volume	= 205,511 cuft
Inflow hyd. No.	= 4 - DA 1.2	Max. Elevation	= 802.63 ft
Reservoir name	= Detention Basin #2	Max. Storage	= 145,351 cuft

Storage Indication method used.

### Thru Detention Basin#2

Hyd. No. 5 -- 2 Year

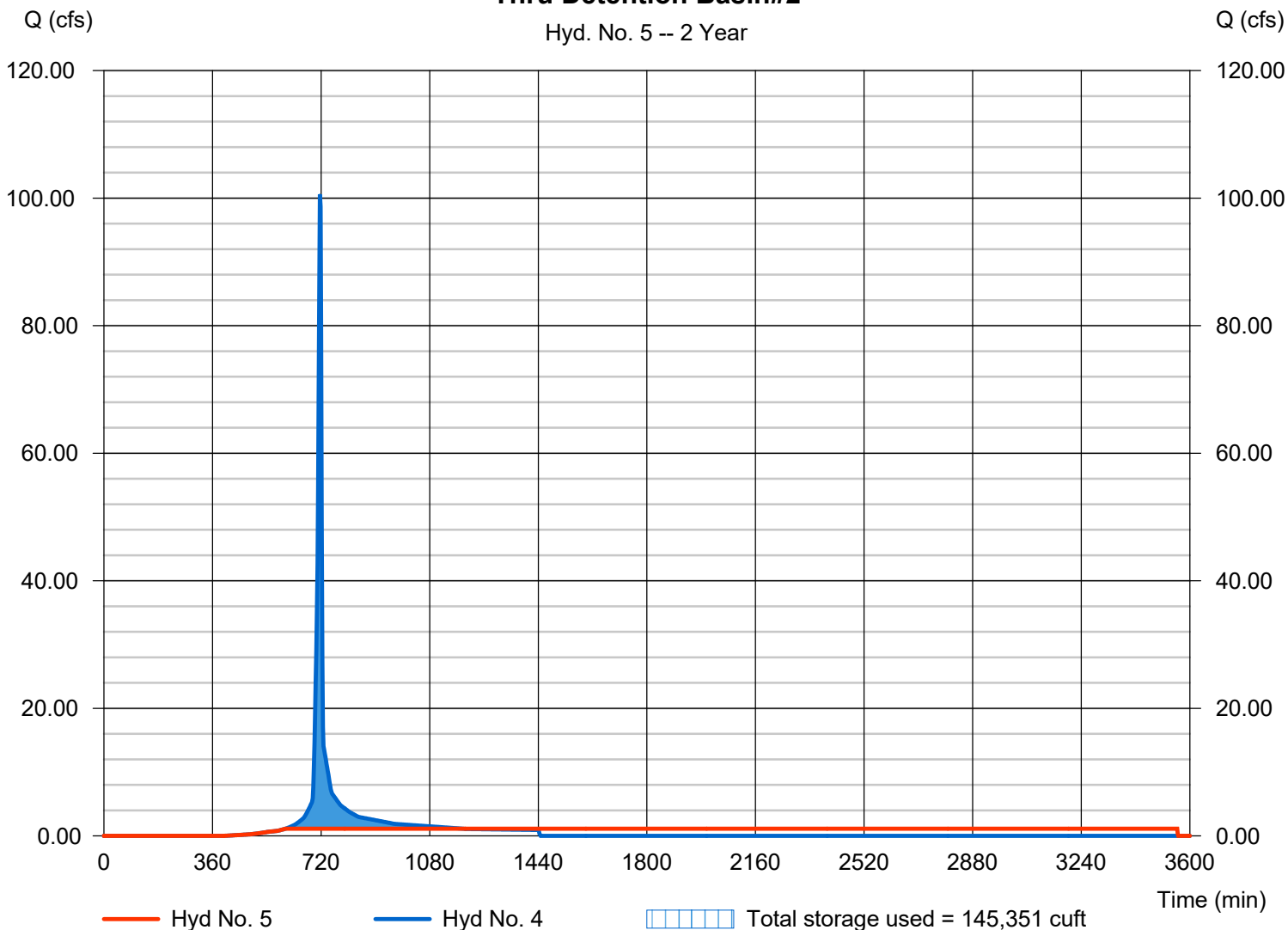

## Pond No. 3 - Detention Basin #2

### Pond Data

Contours -User-defined contour areas. Conic method used for volume calculation. Begining Elevation = 799.00 ft

### Stage / Storage Table

Stage (ft)	Elevation (ft)	Contour area (sqft)	Incr. Storage (cuft)	Total storage (cuft)
0.00	799.00	00	0	0
0.01	799.01	100	0	0
1.00	800.00	23,963	8,451	8,451
2.00	801.00	44,503	33,704	42,155
3.00	802.00	70,732	57,108	99,263
4.00	803.00	76,218	73,451	172,713
5.00	804.00	81,851	79,010	251,723
6.00	805.00	87,605	84,703	336,427
7.00	806.00	93,480	90,518	426,944
8.00	807.00	99,469	96,449	523,393

### Culvert / Orifice Structures

	[A]	[B]	[C]	[PrfRsr]
Rise (in)	= 42.00	0.00	0.00	0.00
Span (in)	= 42.00	0.00	0.00	0.00
No. Barrels	= 1	0	0	0
Invert El. (ft)	= 799.00	0.00	0.00	0.00
Length (ft)	= 100.00	0.00	0.00	0.00
Slope (%)	= 1.00	0.00	0.00	n/a
N-Value	= .013	.013	.013	n/a
Orifice Coeff.	= 0.60	0.60	0.60	0.60
Multi-Stage	= n/a	No	No	No

### Weir Structures

	[A]	[B]	[C]	[D]
Crest Len (ft)	= 14.00	25.00	2.00	0.00
Crest El. (ft)	= 805.00	805.75	804.50	0.00
Weir Coeff.	= 3.33	2.60	3.33	3.33
Weir Type	= 1	Broad	Rect	---
Multi-Stage	= Yes	No	Yes	No
Exfil.(in/hr)	= 0.000 (by Wet area)			
TW Elev. (ft)	= 0.00			

Note: Culvert/Orifice outflows are analyzed under inlet (ic) and outlet (oc) control. Weir risers checked for orifice conditions (ic) and submergence (s).

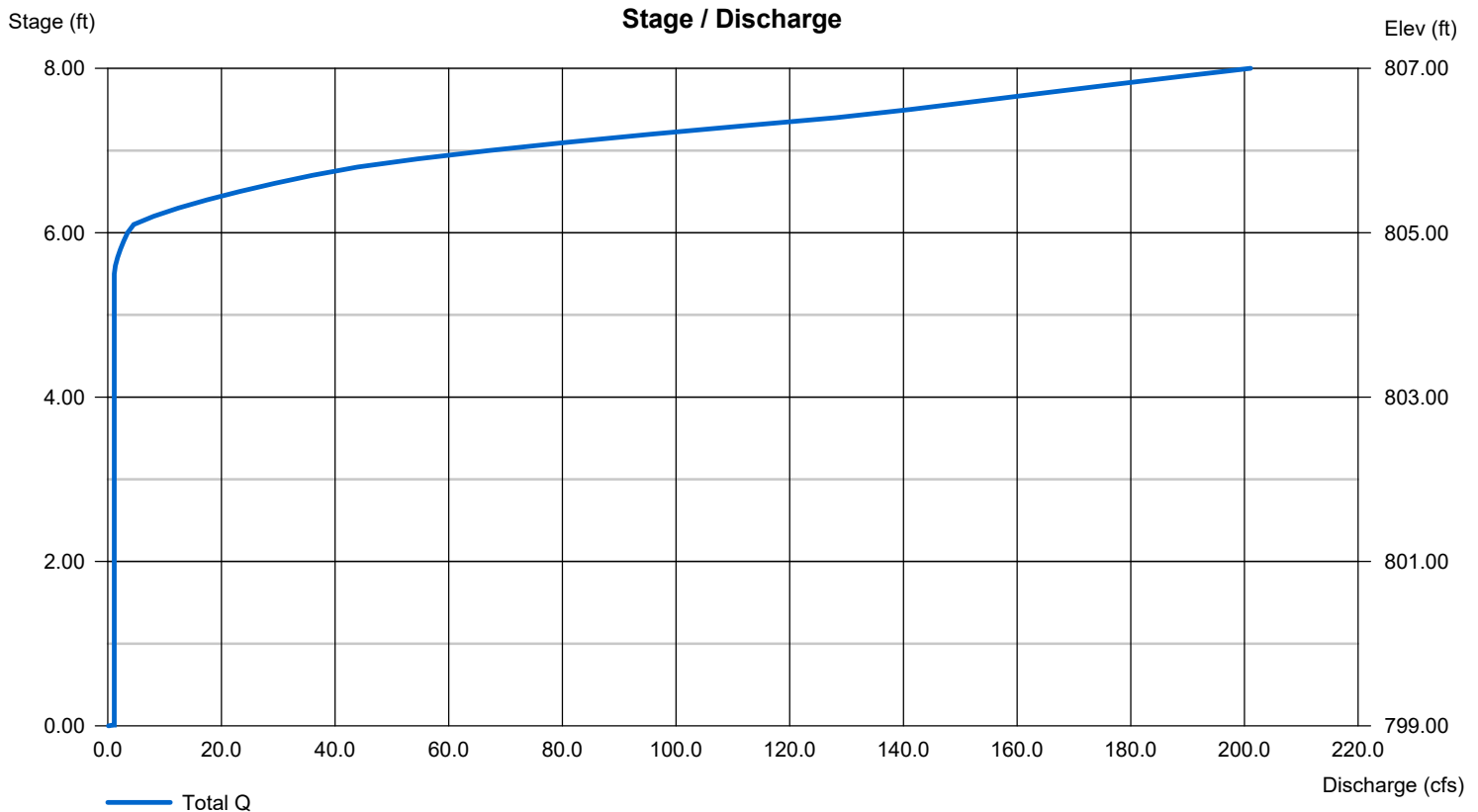

# Hydrograph Report

## Hyd. No. 6

DA BYPASS 2.1

Hydrograph type	= SCS Runoff	Peak discharge	= 9.445 cfs
Storm frequency	= 2 yrs	Time to peak	= 726 min
Time interval	= 2 min	Hyd. volume	= 39,077 cuft
Drainage area	= 17.410 ac	Curve number	= 61
Basin Slope	= 0.0 %	Hydraulic length	= 0 ft
Tc method	= TR55	Time of conc. (Tc)	= 17.40 min
Total precip.	= 3.60 in	Distribution	= Type II
Storm duration	= 24 hrs	Shape factor	= 484

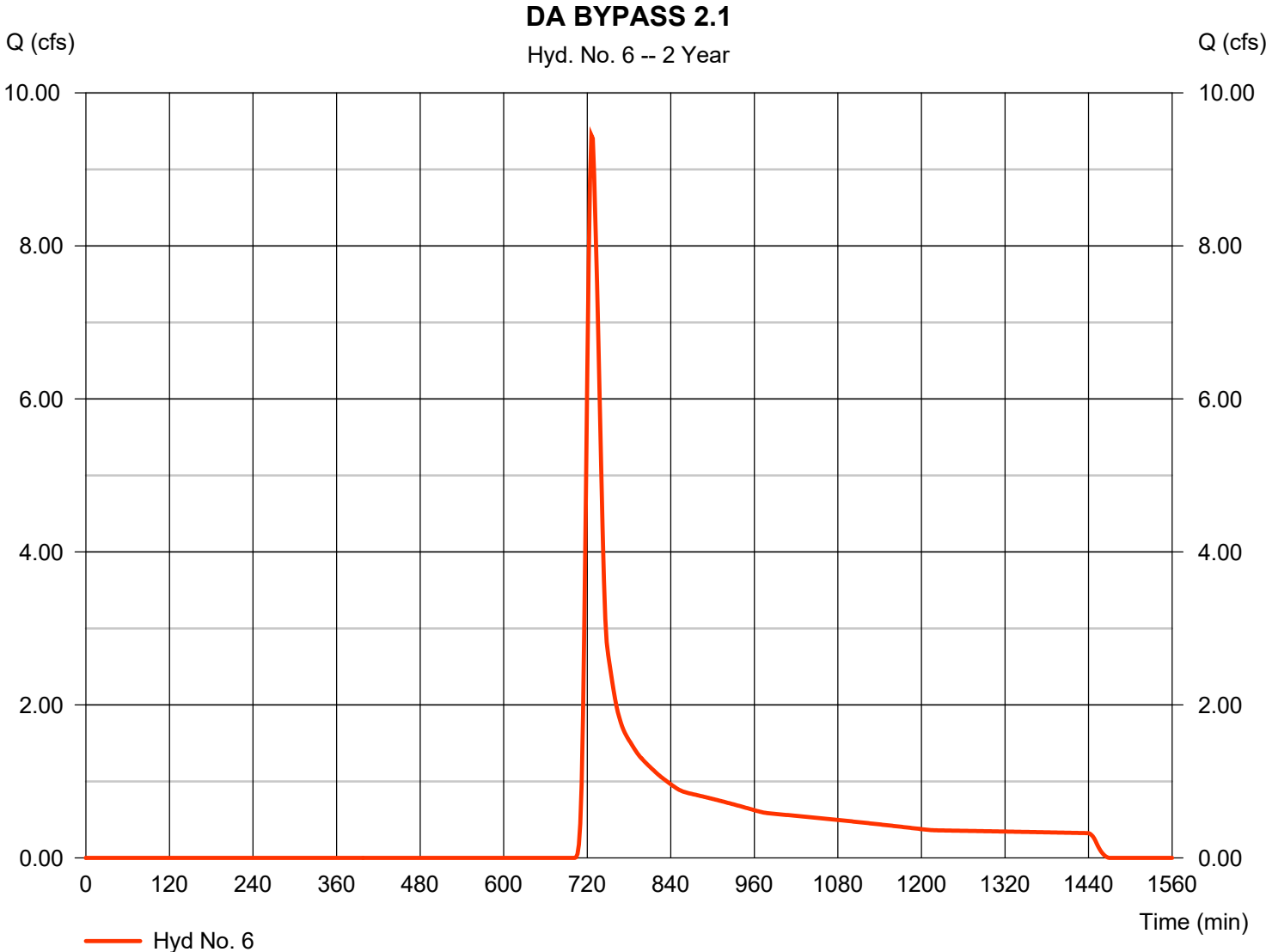

# TR55 Tc Worksheet

Hydraflow Hydrographs Extension for AutoCAD® Civil 3D® 2016 by Autodesk, Inc. v11

## Hyd. No. 6

DA BYPASS 2.1

<u>Description</u>	<u>A</u>	<u>B</u>	<u>C</u>	<u>Totals</u>
<b>Sheet Flow</b>				
Manning's n-value	= 0.400	0.011	0.011	
Flow length (ft)	= 100.0	0.0	0.0	
Two-year 24-hr precip. (in)	= 3.60	0.00	0.00	
Land slope (%)	= 5.00	0.00	0.00	
<b>Travel Time (min)</b>	<b>= 14.03</b>	<b>+ 0.00</b>	<b>+ 0.00</b>	<b>= 14.03</b>
<b>Shallow Concentrated Flow</b>				
Flow length (ft)	= 562.00	0.00	0.00	
Watercourse slope (%)	= 3.02	0.00	0.00	
Surface description	= Unpaved	Paved	Paved	
Average velocity (ft/s)	=2.80	0.00	0.00	
<b>Travel Time (min)</b>	<b>= 3.34</b>	<b>+ 0.00</b>	<b>+ 0.00</b>	<b>= 3.34</b>
<b>Channel Flow</b>				
X sectional flow area (sqft)	= 0.00	0.00	0.00	
Wetted perimeter (ft)	= 0.00	0.00	0.00	
Channel slope (%)	= 0.00	0.00	0.00	
Manning's n-value	= 0.015	0.015	0.015	
Velocity (ft/s)	=0.00	0.00	0.00	
Flow length (ft)	0.0	0.0	0.0	
<b>Travel Time (min)</b>	<b>= 0.00</b>	<b>+ 0.00</b>	<b>+ 0.00</b>	<b>= 0.00</b>
<b>Total Travel Time, Tc .....</b>				<b>17.40 min</b>

# Hydrograph Report

Hydraflow Hydrographs Extension for AutoCAD® Civil 3D® 2016 by Autodesk, Inc. v11

Thursday, 04 / 26 / 2018

## Hyd. No. 7

Thru Detention Basin#3

Hydrograph type	= Reservoir	Peak discharge	= 2.258 cfs
Storm frequency	= 2 yrs	Time to peak	= 872 min
Time interval	= 2 min	Hyd. volume	= 167,414 cuft
Inflow hyd. No.	= 3 - DA 2.1	Max. Elevation	= 806.08 ft
Reservoir name	= Detention Basin #3	Max. Storage	= 103,872 cuft

Storage Indication method used.

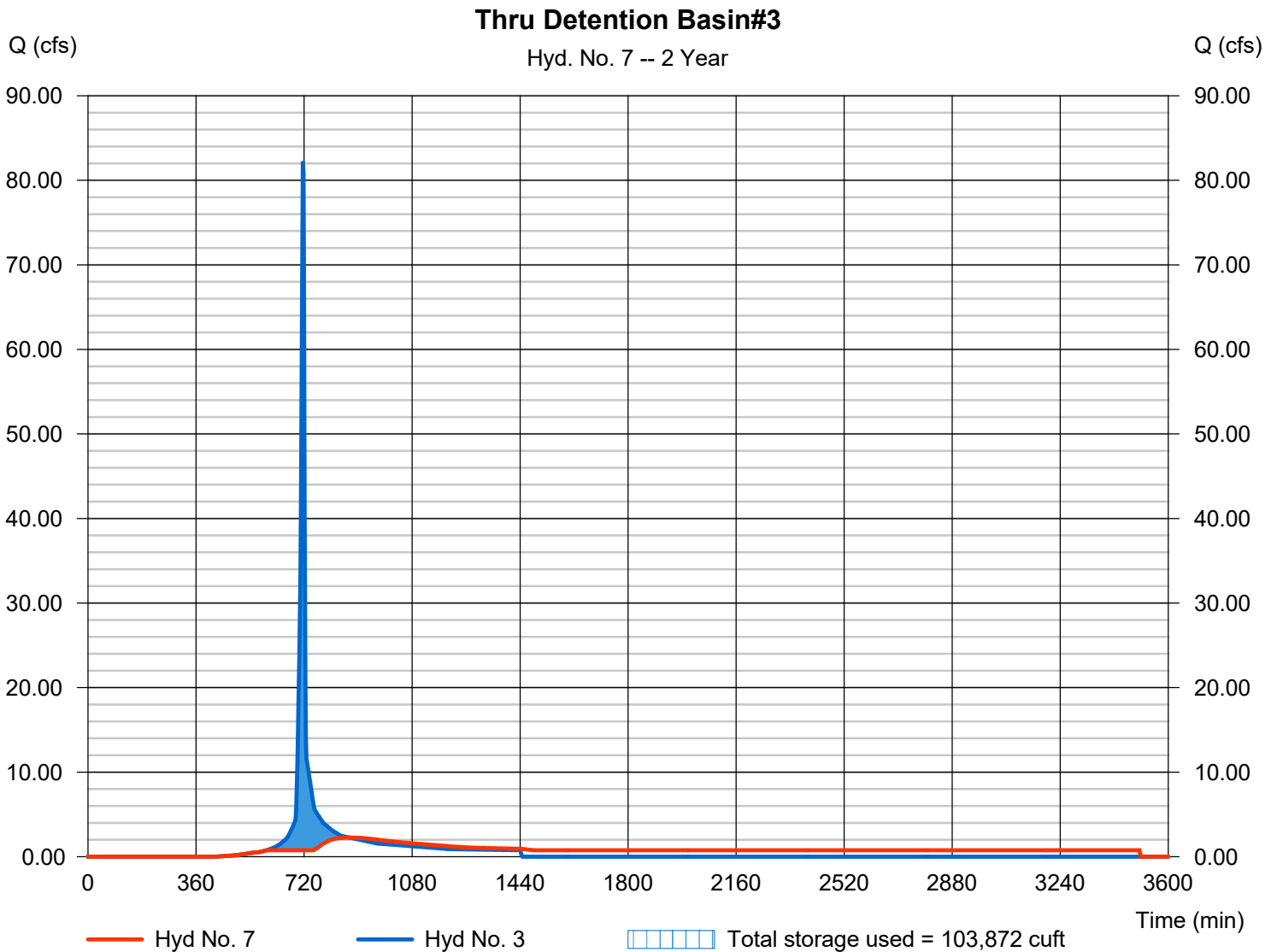

## Pond No. 7 - Detention Basin #3

### Pond Data

Contours -User-defined contour areas. Conic method used for volume calculation. Begining Elevation = 802.00 ft

### Stage / Storage Table

Stage (ft)	Elevation (ft)	Contour area (sqft)	Incr. Storage (cuft)	Total storage (cuft)
0.00	802.00	00	0	0
0.01	802.10	100	0	0
1.00	803.00	10,959	3,995	3,995
2.00	804.00	30,577	19,945	23,940
3.00	805.00	39,703	35,037	58,978
4.00	806.00	42,916	41,295	100,272
5.00	807.00	46,186	44,537	144,809
6.00	808.00	49,513	47,835	192,644
7.00	809.00	52,896	51,190	243,834
8.00	810.00	56,335	54,601	298,434
8.50	810.50	58,076	28,599	327,033

### Culvert / Orifice Structures

	[A]	[B]	[C]	[PrfRsr]
Rise (in)	= 36.00	0.00	0.00	0.00
Span (in)	= 36.00	0.00	0.00	0.00
No. Barrels	= 1	0	0	0
Invert El. (ft)	= 802.00	0.00	0.00	0.00
Length (ft)	= 92.00	0.00	0.00	0.00
Slope (%)	= 0.54	0.00	0.00	n/a
N-Value	= .013	.013	.013	n/a
Orifice Coeff.	= 0.60	0.60	0.60	0.60
Multi-Stage	= n/a	No	No	No

### Weir Structures

	[A]	[B]	[C]	[D]
Crest Len (ft)	= 13.00	40.00	3.00	0.00
Crest El. (ft)	= 808.00	808.50	805.80	0.00
Weir Coeff.	= 3.33	2.60	3.33	3.33
Weir Type	= 1	Broad	Rect	---
Multi-Stage	= Yes	No	Yes	No
Exfil.(in/hr)	= 0.000 (by Wet area)			
TW Elev. (ft)	= 0.00			

Note: Culvert/Orifice outflows are analyzed under inlet (ic) and outlet (oc) control. Weir risers checked for orifice conditions (ic) and submergence (s).

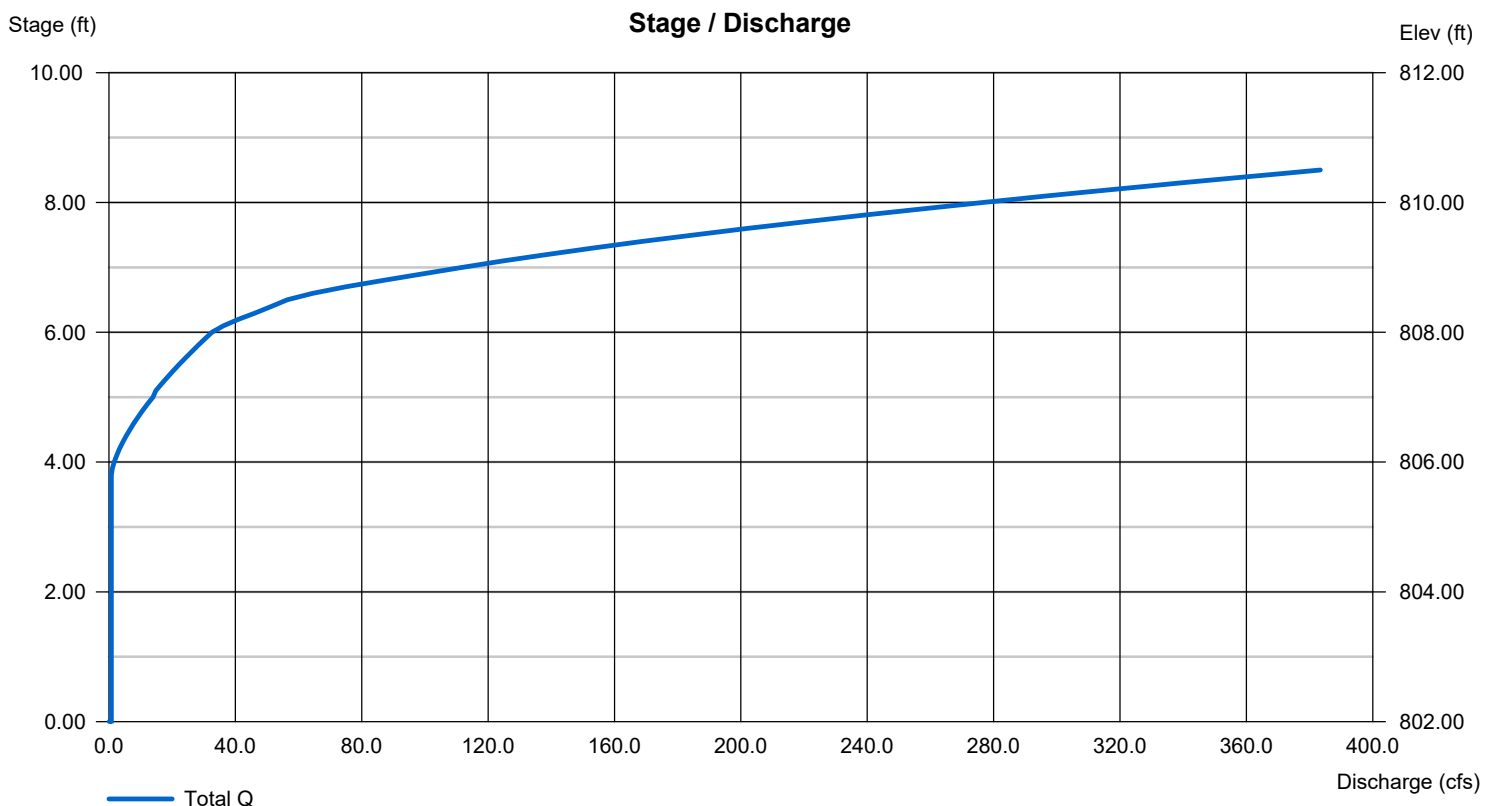

# Hydrograph Report

Hydraflow Hydrographs Extension for AutoCAD® Civil 3D® 2016 by Autodesk, Inc. v11

Thursday, 04 / 26 / 2018

## Hyd. No. 8

Total Post Development DA 2.1

Hydrograph type = Combine  
Storm frequency = 2 yrs  
Time interval = 2 min  
Inflow hyds. = 6, 7

Peak discharge = 10.21 cfs  
Time to peak = 726 min  
Hyd. volume = 206,490 cuft  
Contrib. drain. area = 17.410 ac

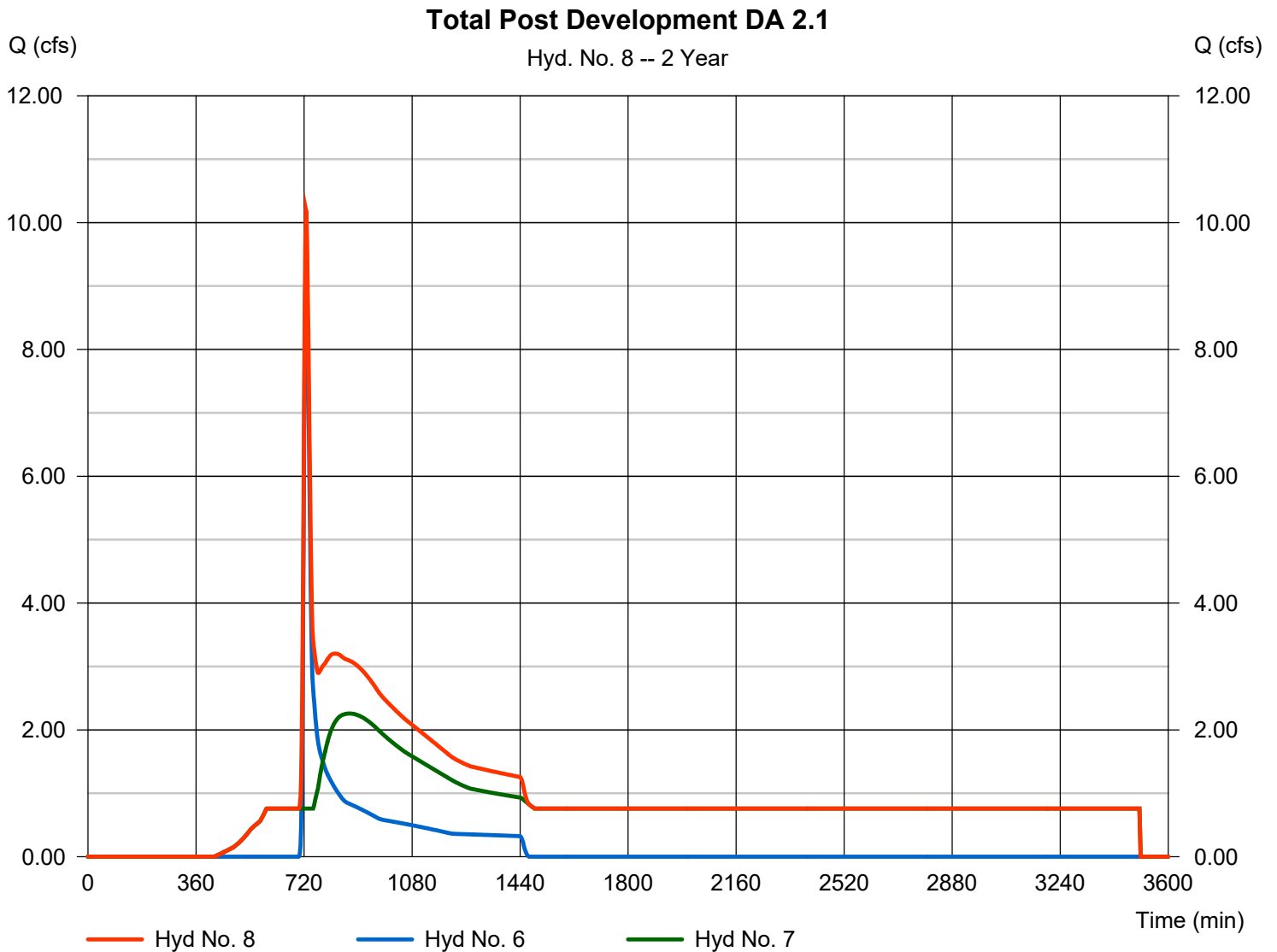



# Hydrograph Summary Report

Hydraflow Hydrographs Extension for AutoCAD® Civil 3D® 2016 by Autodesk, Inc. v11

Hyd. No.	Hydrograph type (origin)	Peak flow (cfs)	Time interval (min)	Time to Peak (min)	Hyd. volume (cuft)	Inflow hyd(s)	Maximum elevation (ft)	Total strge used (cuft)	Hydrograph Description
1	SCS Runoff	110.65	2	716	232,270	-----	-----	-----	DA 1.1
2	Reservoir	0.805	2	1442	195,877	1	810.03	192,473	Thru Detention Basi #1
3	SCS Runoff	146.12	2	716	304,966	-----	-----	-----	DA 2.1
4	SCS Runoff	176.19	2	716	369,837	-----	-----	-----	DA 1.2
5	Reservoir	1.244	2	1442	364,071	4	804.55	298,651	Thru Detention Basin#2
6	SCS Runoff	31.88	2	726	106,094	-----	-----	-----	DA BYPASS 2.1
7	Reservoir	16.40	2	736	304,978	3	807.19	153,964	Thru Detention Basin#3
8	Combine	47.67	2	726	411,063	6, 7	-----	-----	Total Post Development DA 2.1
16227-Basin Design - 3 Ponds.gpw					Return Period: 10 Year			Thursday, 04 / 26 / 2018	

# Hydrograph Report

## Hyd. No. 1

DA 1.1

Hydrograph type	= SCS Runoff	Peak discharge	= 110.65 cfs
Storm frequency	= 10 yrs	Time to peak	= 716 min
Time interval	= 2 min	Hyd. volume	= 232,270 cuft
Drainage area	= 17.340 ac	Curve number	= 86
Basin Slope	= 0.0 %	Hydraulic length	= 0 ft
Tc method	= User	Time of conc. (Tc)	= 6.00 min
Total precip.	= 5.50 in	Distribution	= Type II
Storm duration	= 24 hrs	Shape factor	= 484

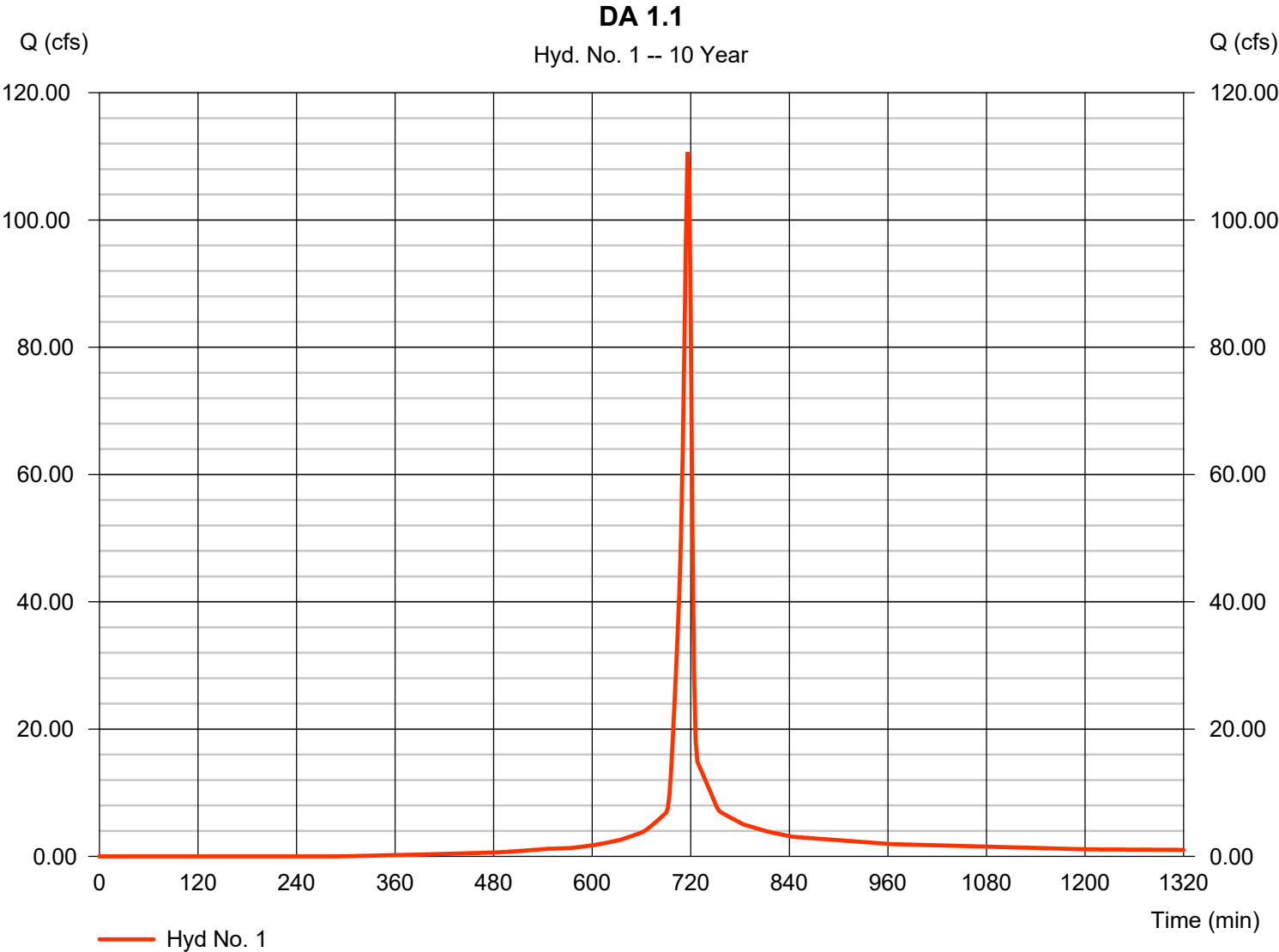

# Hydrograph Report

Hydraflow Hydrographs Extension for AutoCAD® Civil 3D® 2016 by Autodesk, Inc. v11

Thursday, 04 / 26 / 2018

## Hyd. No. 2

Thru Detention Basi #1

Hydrograph type	= Reservoir	Peak discharge	= 0.805 cfs
Storm frequency	= 10 yrs	Time to peak	= 1442 min
Time interval	= 2 min	Hyd. volume	= 195,877 cuft
Inflow hyd. No.	= 1 - DA 1.1	Max. Elevation	= 810.03 ft
Reservoir name	= Detention Basin #1	Max. Storage	= 192,473 cuft

Storage Indication method used.

### Thru Detention Basi #1

Hyd. No. 2 -- 10 Year

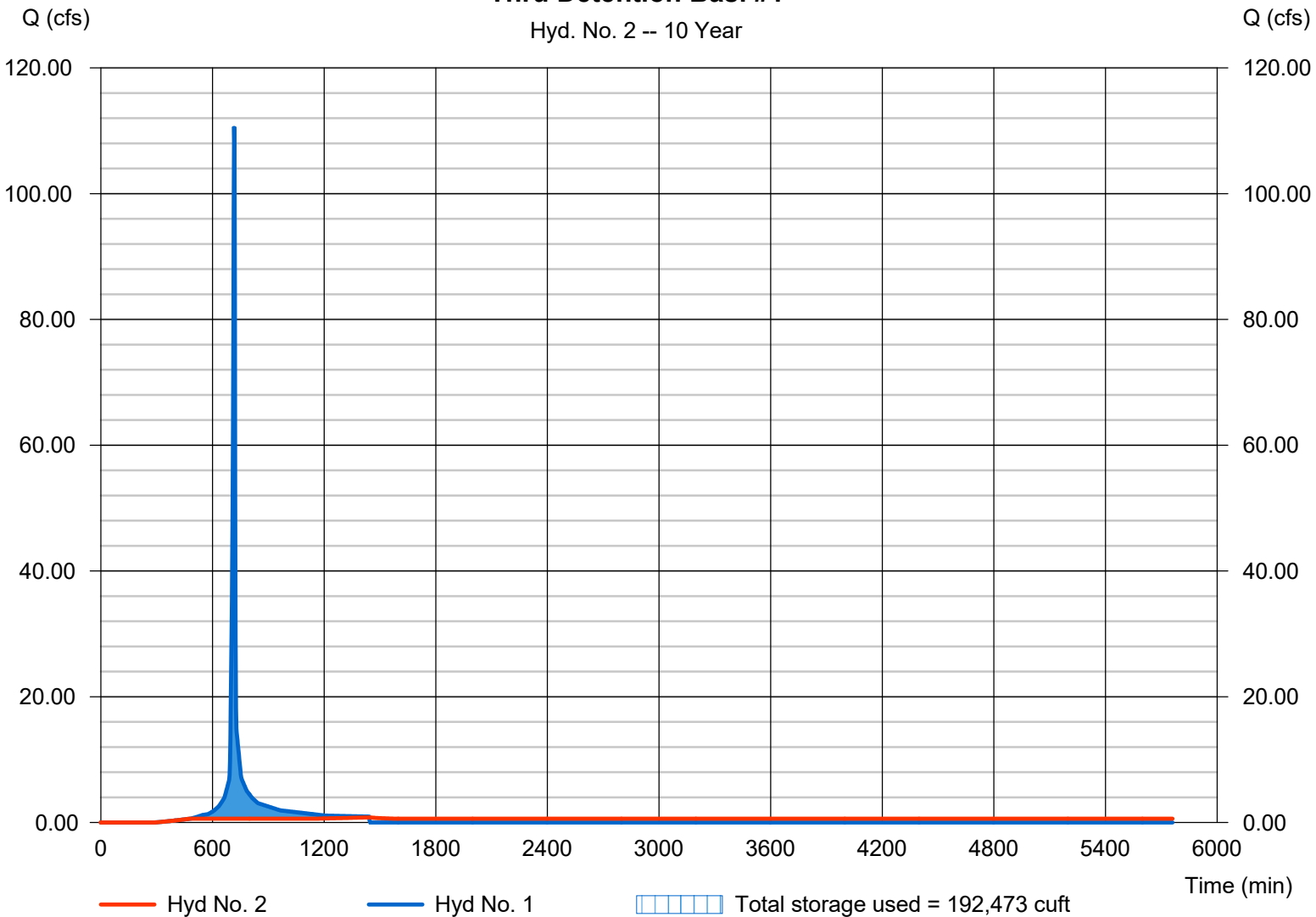

# Hydrograph Report

Hydraflow Hydrographs Extension for AutoCAD® Civil 3D® 2016 by Autodesk, Inc. v11

Thursday, 04 / 26 / 2018

## Hyd. No. 3

DA 2.1

Hydrograph type	= SCS Runoff	Peak discharge	= 146.12 cfs
Storm frequency	= 10 yrs	Time to peak	= 716 min
Time interval	= 2 min	Hyd. volume	= 304,966 cuft
Drainage area	= 23.380 ac	Curve number	= 85
Basin Slope	= 0.0 %	Hydraulic length	= 0 ft
Tc method	= User	Time of conc. (Tc)	= 6.00 min
Total precip.	= 5.50 in	Distribution	= Type II
Storm duration	= 24 hrs	Shape factor	= 484

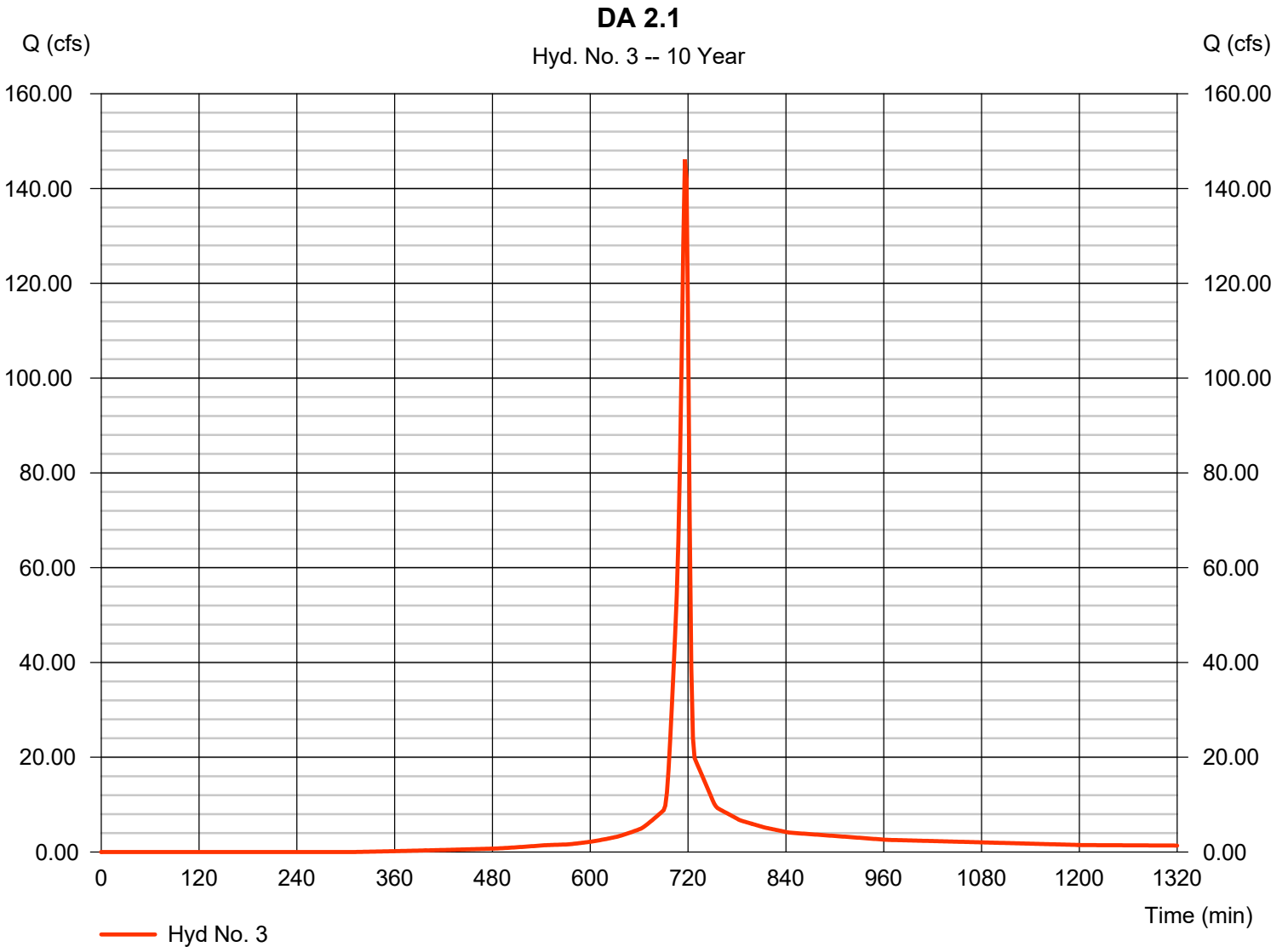

# Hydrograph Report

Hydraflow Hydrographs Extension for AutoCAD® Civil 3D® 2016 by Autodesk, Inc. v11

Thursday, 04 / 26 / 2018

## Hyd. No. 4

DA 1.2

Hydrograph type	= SCS Runoff	Peak discharge	= 176.19 cfs
Storm frequency	= 10 yrs	Time to peak	= 716 min
Time interval	= 2 min	Hyd. volume	= 369,837 cuft
Drainage area	= 27.610 ac	Curve number	= 86
Basin Slope	= 0.0 %	Hydraulic length	= 0 ft
Tc method	= User	Time of conc. (Tc)	= 6.00 min
Total precip.	= 5.50 in	Distribution	= Type II
Storm duration	= 24 hrs	Shape factor	= 484

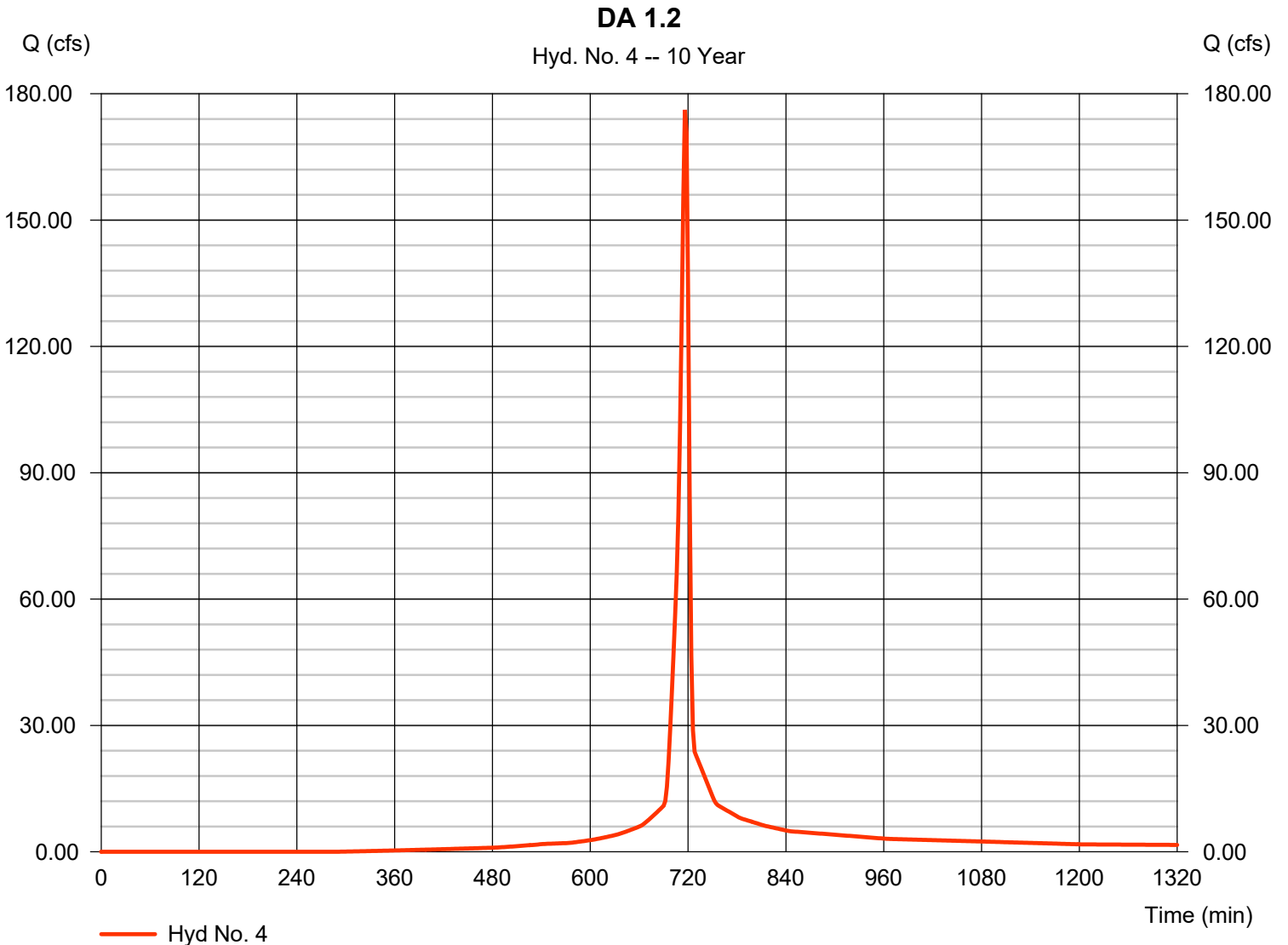

# Hydrograph Report

Hydraflow Hydrographs Extension for AutoCAD® Civil 3D® 2016 by Autodesk, Inc. v11

Thursday, 04 / 26 / 2018

## Hyd. No. 5

Thru Detention Basin#2

Hydrograph type	= Reservoir	Peak discharge	= 1.244 cfs
Storm frequency	= 10 yrs	Time to peak	= 1442 min
Time interval	= 2 min	Hyd. volume	= 364,071 cuft
Inflow hyd. No.	= 4 - DA 1.2	Max. Elevation	= 804.55 ft
Reservoir name	= Detention Basin #2	Max. Storage	= 298,651 cuft

Storage Indication method used.

### Thru Detention Basin#2

Hyd. No. 5 -- 10 Year

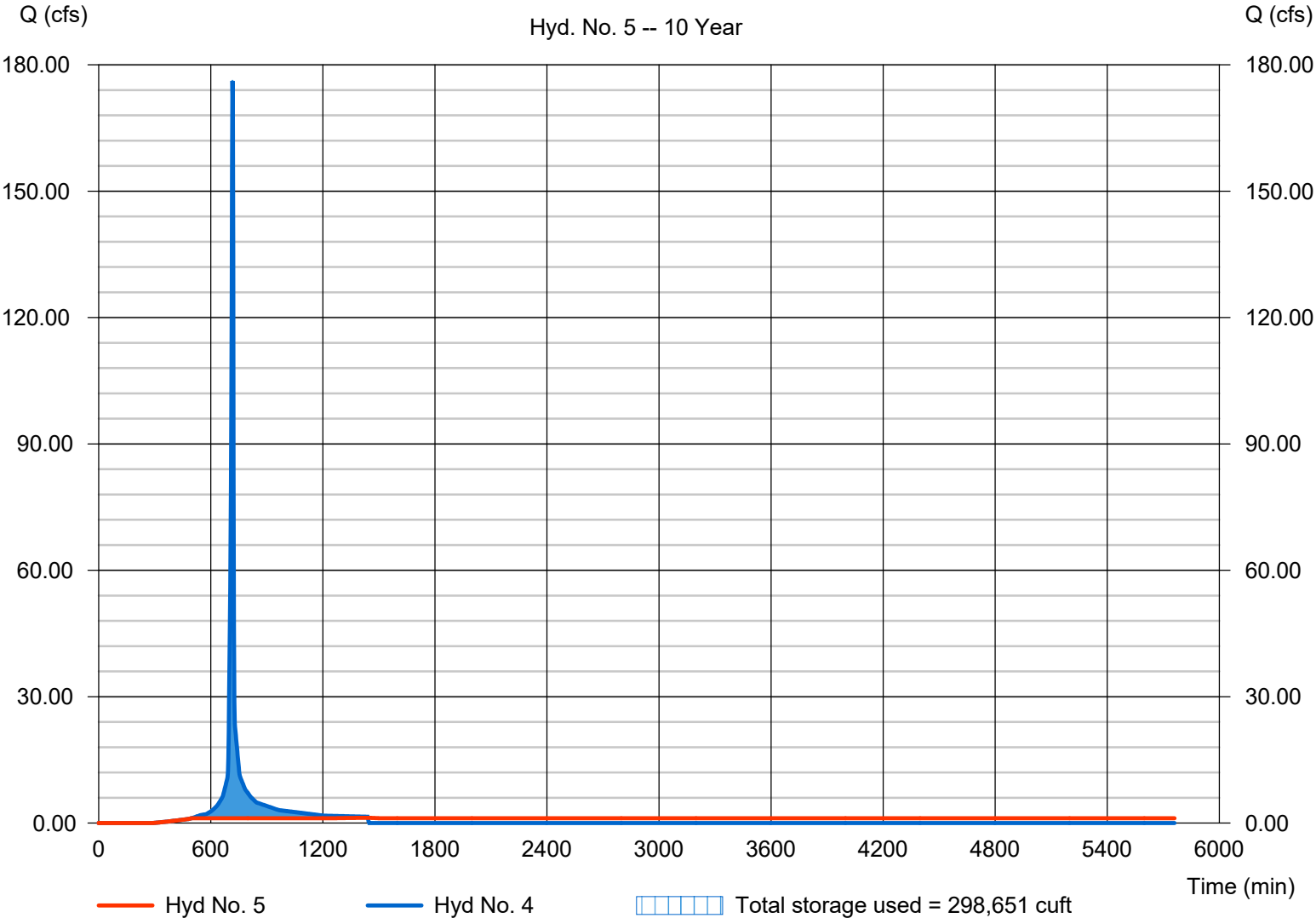

# Hydrograph Report

Hydraflow Hydrographs Extension for AutoCAD® Civil 3D® 2016 by Autodesk, Inc. v11

Thursday, 04 / 26 / 2018

## Hyd. No. 6

DA BYPASS 2.1

Hydrograph type = SCS Runoff  
 Storm frequency = 10 yrs  
 Time interval = 2 min  
 Drainage area = 17.410 ac  
 Basin Slope = 0.0 %  
 Tc method = TR55  
 Total precip. = 5.50 in  
 Storm duration = 24 hrs

Peak discharge = 31.88 cfs  
 Time to peak = 726 min  
 Hyd. volume = 106,094 cuft  
 Curve number = 61  
 Hydraulic length = 0 ft  
 Time of conc. (Tc) = 17.40 min  
 Distribution = Type II  
 Shape factor = 484

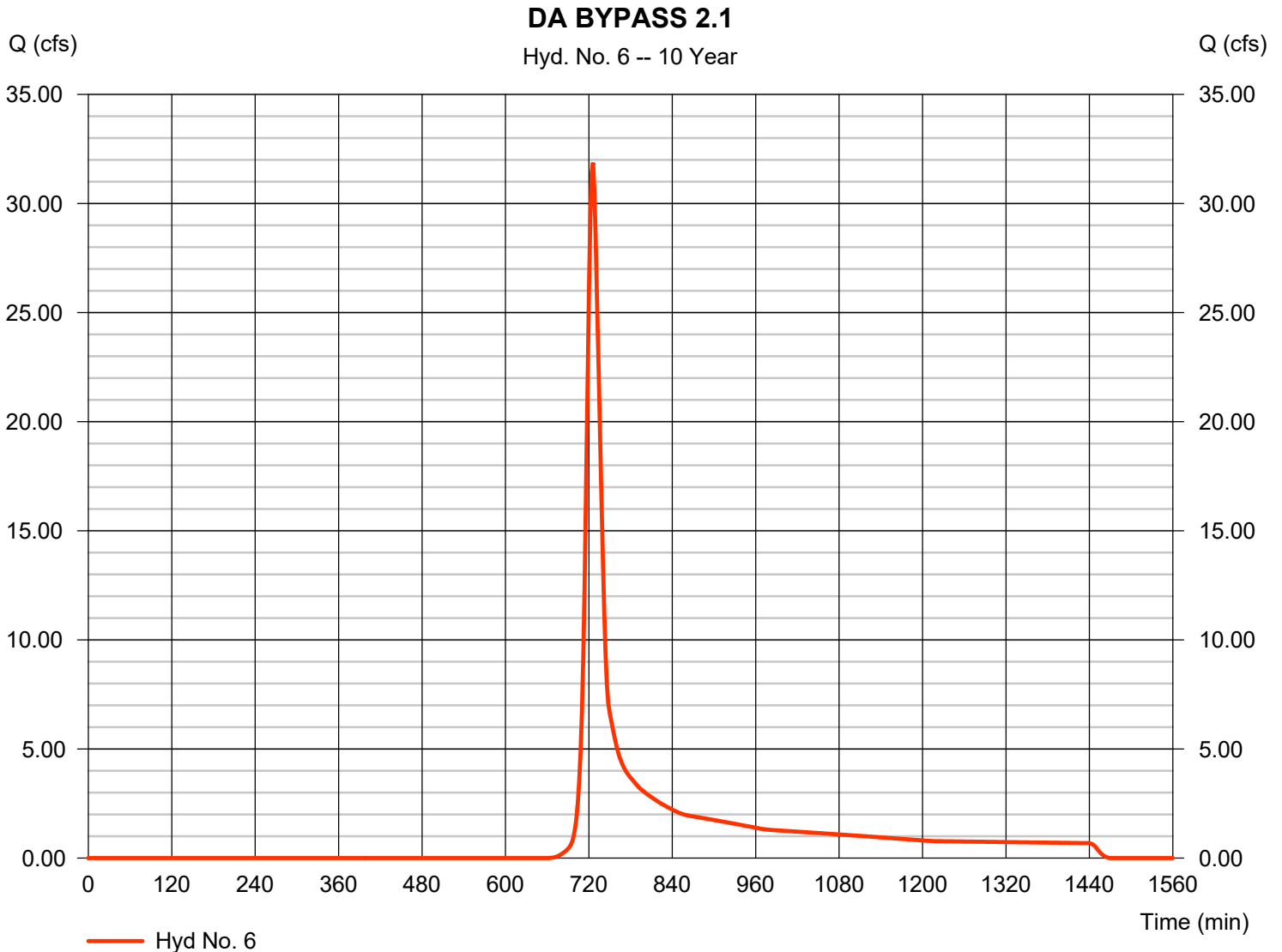

# Hydrograph Report

Hydraflow Hydrographs Extension for AutoCAD® Civil 3D® 2016 by Autodesk, Inc. v11

Thursday, 04 / 26 / 2018

## Hyd. No. 7

Thru Detention Basin#3

Hydrograph type	= Reservoir	Peak discharge	= 16.40 cfs
Storm frequency	= 10 yrs	Time to peak	= 736 min
Time interval	= 2 min	Hyd. volume	= 304,978 cuft
Inflow hyd. No.	= 3 - DA 2.1	Max. Elevation	= 807.19 ft
Reservoir name	= Detention Basin #3	Max. Storage	= 153,964 cuft

Storage Indication method used.

### Thru Detention Basin#3

Hyd. No. 7 -- 10 Year

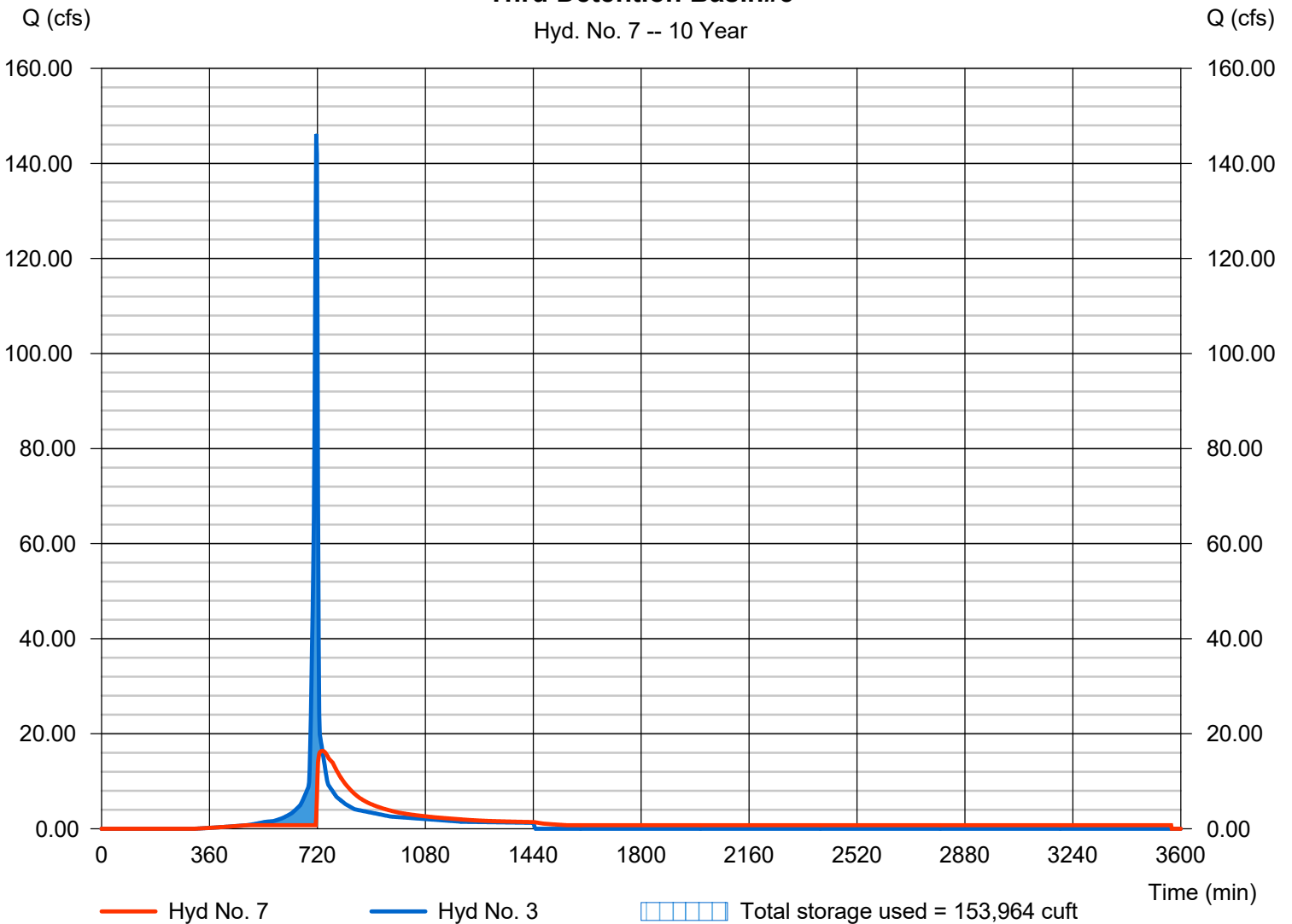



# Hydrograph Report

Hydraflow Hydrographs Extension for AutoCAD® Civil 3D® 2016 by Autodesk, Inc. v11

Thursday, 04 / 26 / 2018

## Hyd. No. 8

Total Post Development DA 2.1

Hydrograph type = Combine  
Storm frequency = 10 yrs  
Time interval = 2 min  
Inflow hyds. = 6, 7

Peak discharge = 47.67 cfs  
Time to peak = 726 min  
Hyd. volume = 411,063 cuft  
Contrib. drain. area = 17.410 ac

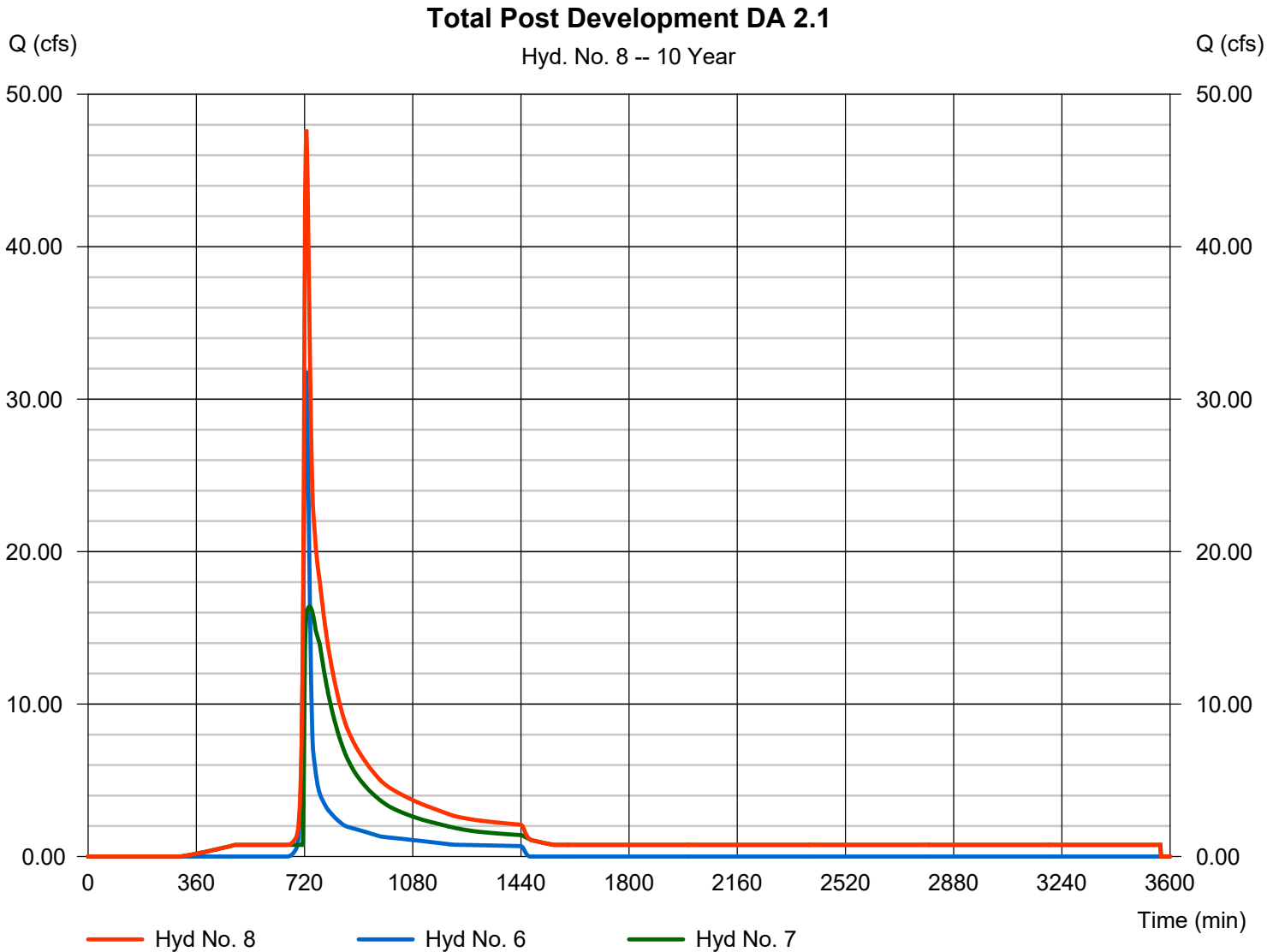

# Hydrograph Summary Report

Hydraflow Hydrographs Extension for AutoCAD® Civil 3D® 2016 by Autodesk, Inc. v11

Hyd. No.	Hydrograph type (origin)	Peak flow (cfs)	Time interval (min)	Time to Peak (min)	Hyd. volume (cuft)	Inflow hyd(s)	Maximum elevation (ft)	Total strge used (cuft)	Hydrograph Description	
1	SCS Runoff	138.14	2	716	293,981	-----	-----	-----	DA 1.1	
2	Reservoir	2.516	2	950	253,037	1	810.45	211,155	Thru Detention Basi #1	
3	SCS Runoff	183.24	2	716	387,566	-----	-----	-----	DA 2.1	
4	SCS Runoff	219.96	2	716	468,098	-----	-----	-----	DA 1.2	
5	Reservoir	3.573	2	990	447,015	4	805.01	337,162	Thru Detention Basin#2	
6	SCS Runoff	47.26	2	726	152,760	-----	-----	-----	DA BYPASS 2.1	
7	Reservoir	32.33	2	726	387,589	3	807.99	192,060	Thru Detention Basin#3	
8	Combine	79.59	2	726	540,349	6, 7	-----	-----	Total Post Development DA 2.1	
16227-Basin Design - 3 Ponds.gpw					Return Period: 25 Year			Thursday, 04 / 26 / 2018		

# Hydrograph Report

Hydraflow Hydrographs Extension for AutoCAD® Civil 3D® 2016 by Autodesk, Inc. v11

Thursday, 04 / 26 / 2018

## Hyd. No. 1

DA 1.1

Hydrograph type	= SCS Runoff	Peak discharge	= 138.14 cfs
Storm frequency	= 25 yrs	Time to peak	= 716 min
Time interval	= 2 min	Hyd. volume	= 293,981 cuft
Drainage area	= 17.340 ac	Curve number	= 86
Basin Slope	= 0.0 %	Hydraulic length	= 0 ft
Tc method	= User	Time of conc. (Tc)	= 6.00 min
Total precip.	= 6.60 in	Distribution	= Type II
Storm duration	= 24 hrs	Shape factor	= 484

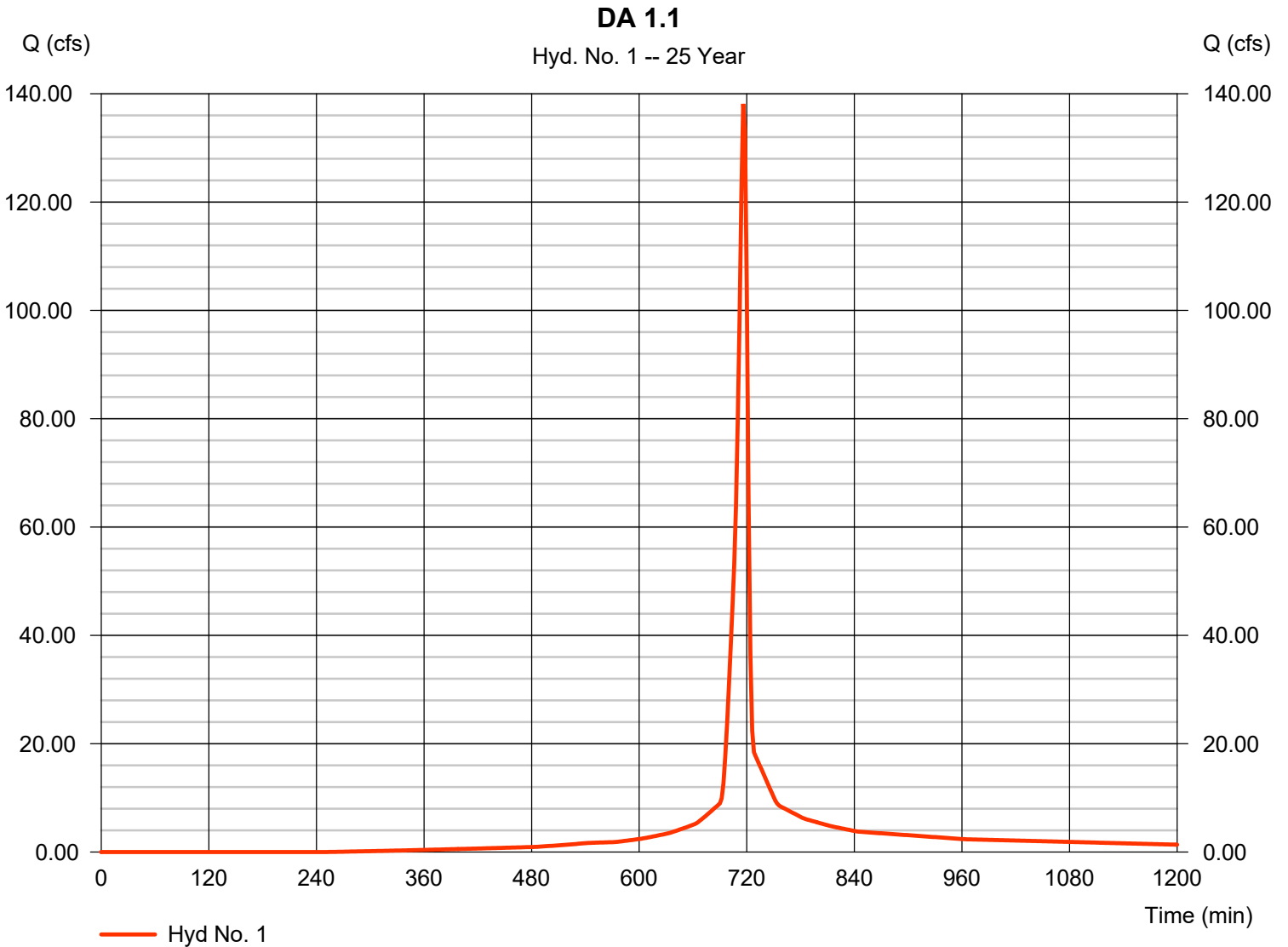

# Hydrograph Report

Hydraflow Hydrographs Extension for AutoCAD® Civil 3D® 2016 by Autodesk, Inc. v11

Thursday, 04 / 26 / 2018

## Hyd. No. 2

Thru Detention Basi #1

Hydrograph type	= Reservoir	Peak discharge	= 2.516 cfs
Storm frequency	= 25 yrs	Time to peak	= 950 min
Time interval	= 2 min	Hyd. volume	= 253,037 cuft
Inflow hyd. No.	= 1 - DA 1.1	Max. Elevation	= 810.45 ft
Reservoir name	= Detention Basin #1	Max. Storage	= 211,155 cuft

Storage Indication method used.

### Thru Detention Basi #1

Hyd. No. 2 -- 25 Year

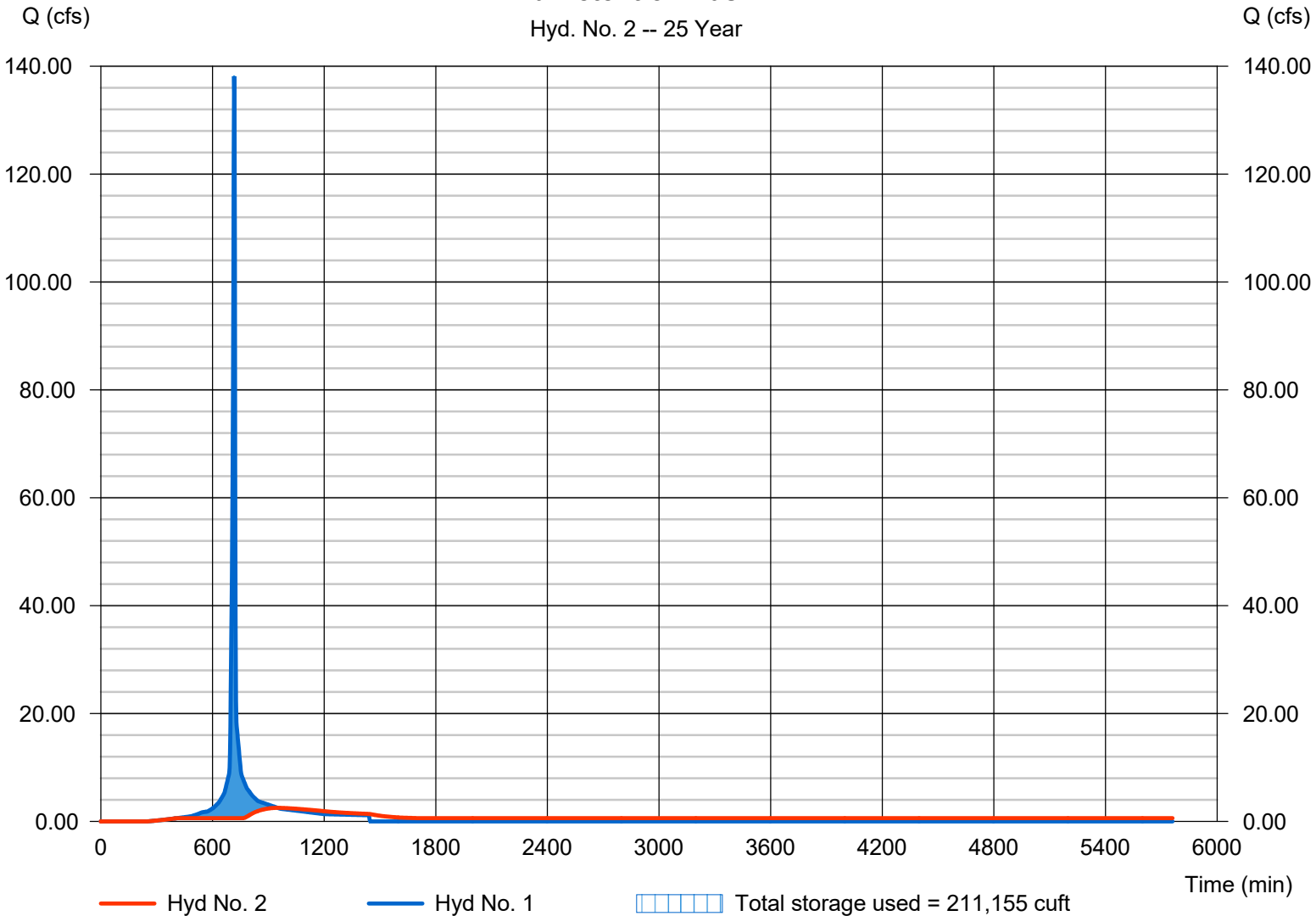

# Hydrograph Report

Hydraflow Hydrographs Extension for AutoCAD® Civil 3D® 2016 by Autodesk, Inc. v11

Thursday, 04 / 26 / 2018

## Hyd. No. 3

DA 2.1

Hydrograph type = SCS Runoff  
 Storm frequency = 25 yrs  
 Time interval = 2 min  
 Drainage area = 23.380 ac  
 Basin Slope = 0.0 %  
 Tc method = User  
 Total precip. = 6.60 in  
 Storm duration = 24 hrs

Peak discharge = 183.24 cfs  
 Time to peak = 716 min  
 Hyd. volume = 387,566 cuft  
 Curve number = 85  
 Hydraulic length = 0 ft  
 Time of conc. (Tc) = 6.00 min  
 Distribution = Type II  
 Shape factor = 484

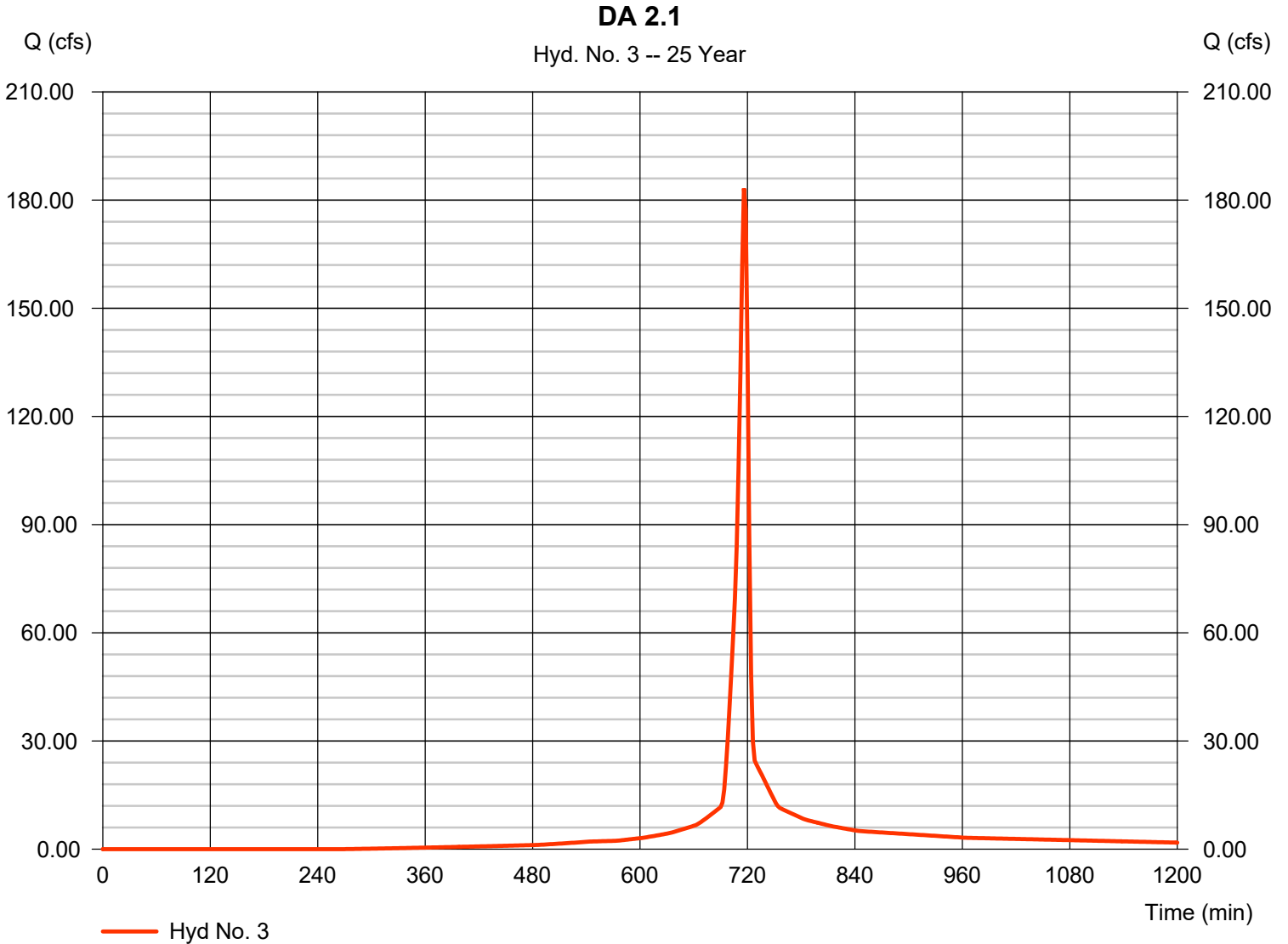

# Hydrograph Report

## Hyd. No. 4

DA 1.2

Hydrograph type	= SCS Runoff	Peak discharge	= 219.96 cfs
Storm frequency	= 25 yrs	Time to peak	= 716 min
Time interval	= 2 min	Hyd. volume	= 468,098 cuft
Drainage area	= 27.610 ac	Curve number	= 86
Basin Slope	= 0.0 %	Hydraulic length	= 0 ft
Tc method	= User	Time of conc. (Tc)	= 6.00 min
Total precip.	= 6.60 in	Distribution	= Type II
Storm duration	= 24 hrs	Shape factor	= 484

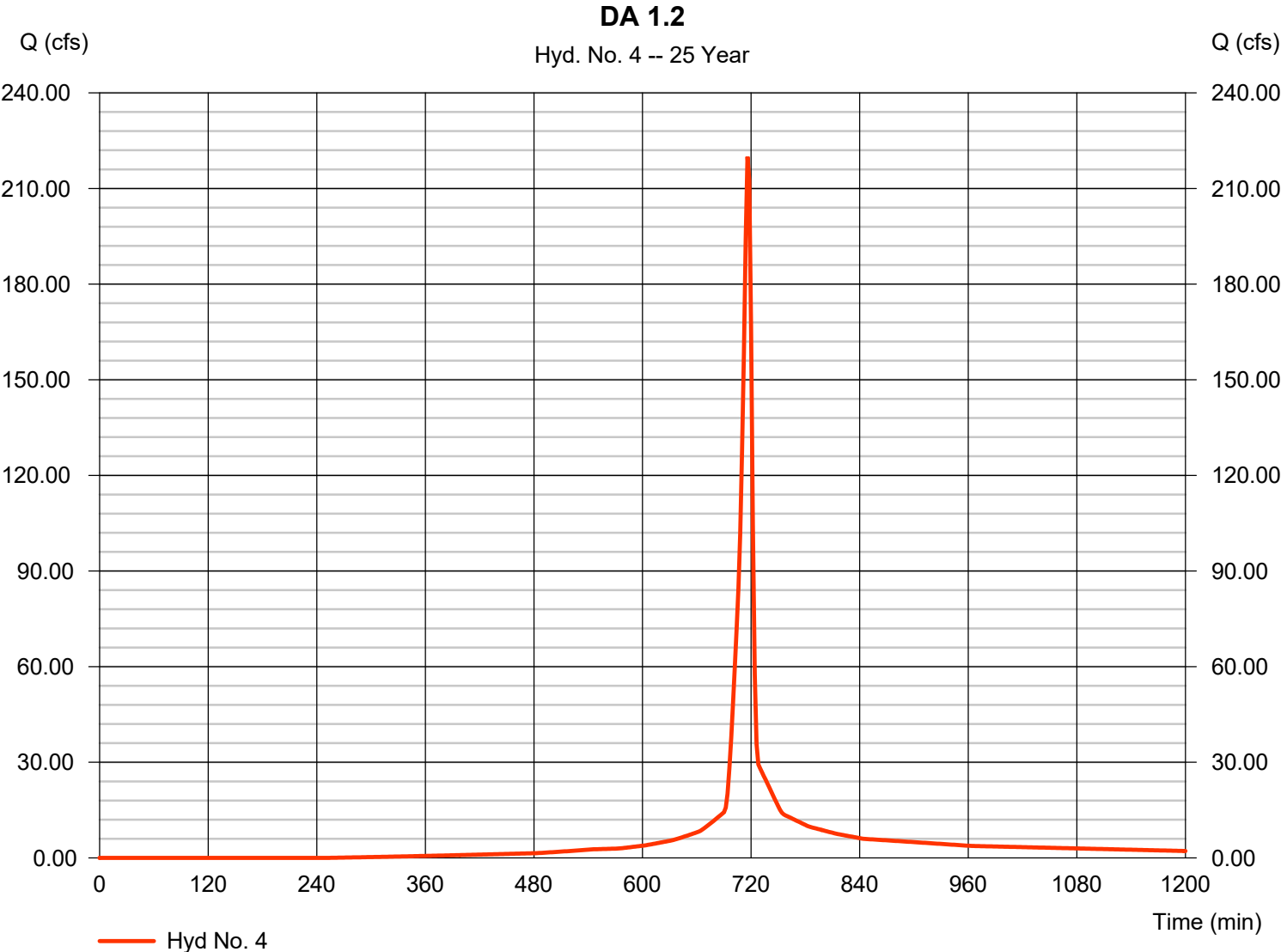

# Hydrograph Report

Hydraflow Hydrographs Extension for AutoCAD® Civil 3D® 2016 by Autodesk, Inc. v11

Thursday, 04 / 26 / 2018

## Hyd. No. 5

Thru Detention Basin#2

Hydrograph type	= Reservoir	Peak discharge	= 3.573 cfs
Storm frequency	= 25 yrs	Time to peak	= 990 min
Time interval	= 2 min	Hyd. volume	= 447,015 cuft
Inflow hyd. No.	= 4 - DA 1.2	Max. Elevation	= 805.01 ft
Reservoir name	= Detention Basin #2	Max. Storage	= 337,162 cuft

Storage Indication method used.

### Thru Detention Basin#2

Hyd. No. 5 -- 25 Year

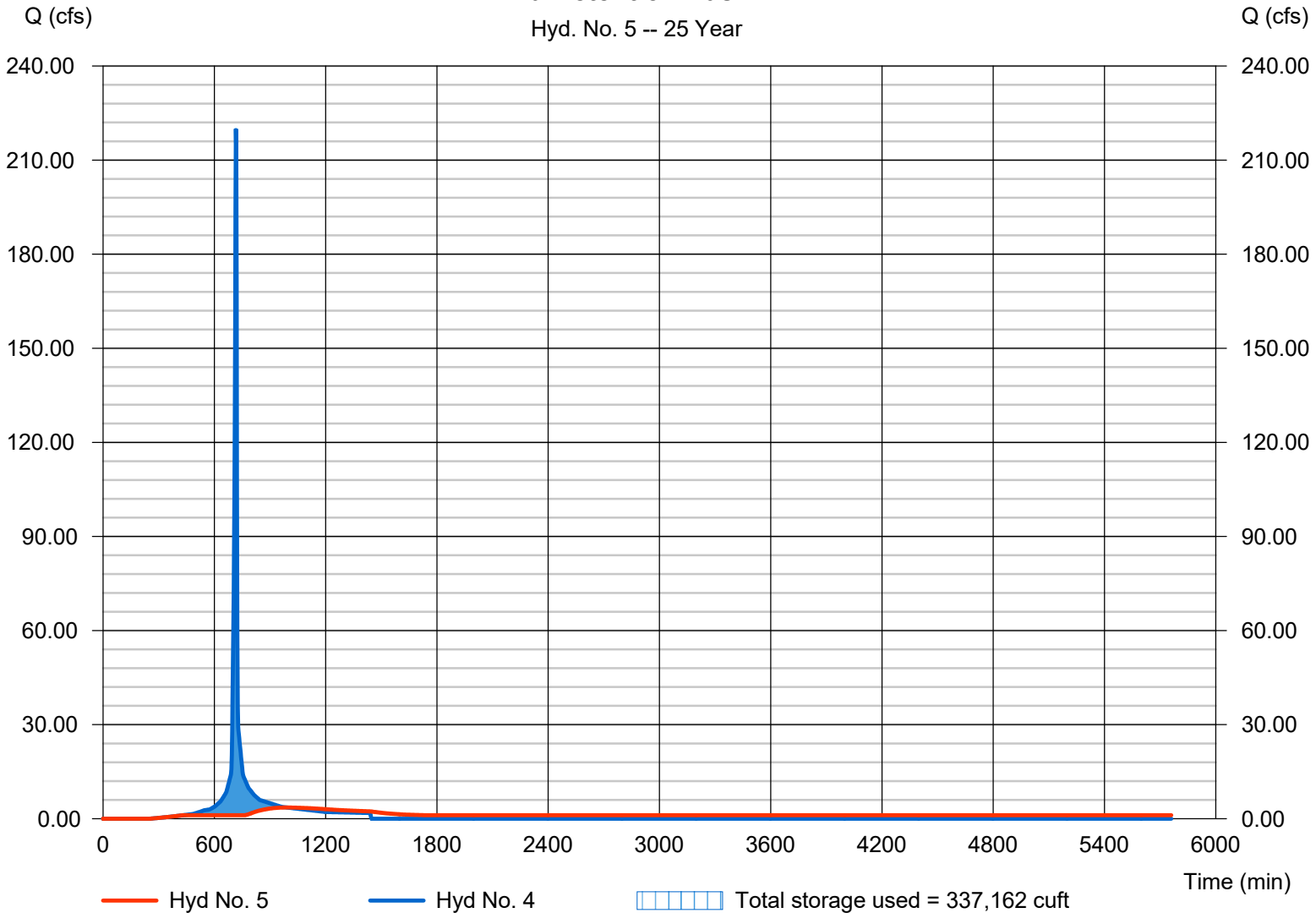

# Hydrograph Report

Hydraflow Hydrographs Extension for AutoCAD® Civil 3D® 2016 by Autodesk, Inc. v11

Thursday, 04 / 26 / 2018

## Hyd. No. 6

DA BYPASS 2.1

Hydrograph type	= SCS Runoff	Peak discharge	= 47.26 cfs
Storm frequency	= 25 yrs	Time to peak	= 726 min
Time interval	= 2 min	Hyd. volume	= 152,760 cuft
Drainage area	= 17.410 ac	Curve number	= 61
Basin Slope	= 0.0 %	Hydraulic length	= 0 ft
Tc method	= TR55	Time of conc. (Tc)	= 17.40 min
Total precip.	= 6.60 in	Distribution	= Type II
Storm duration	= 24 hrs	Shape factor	= 484

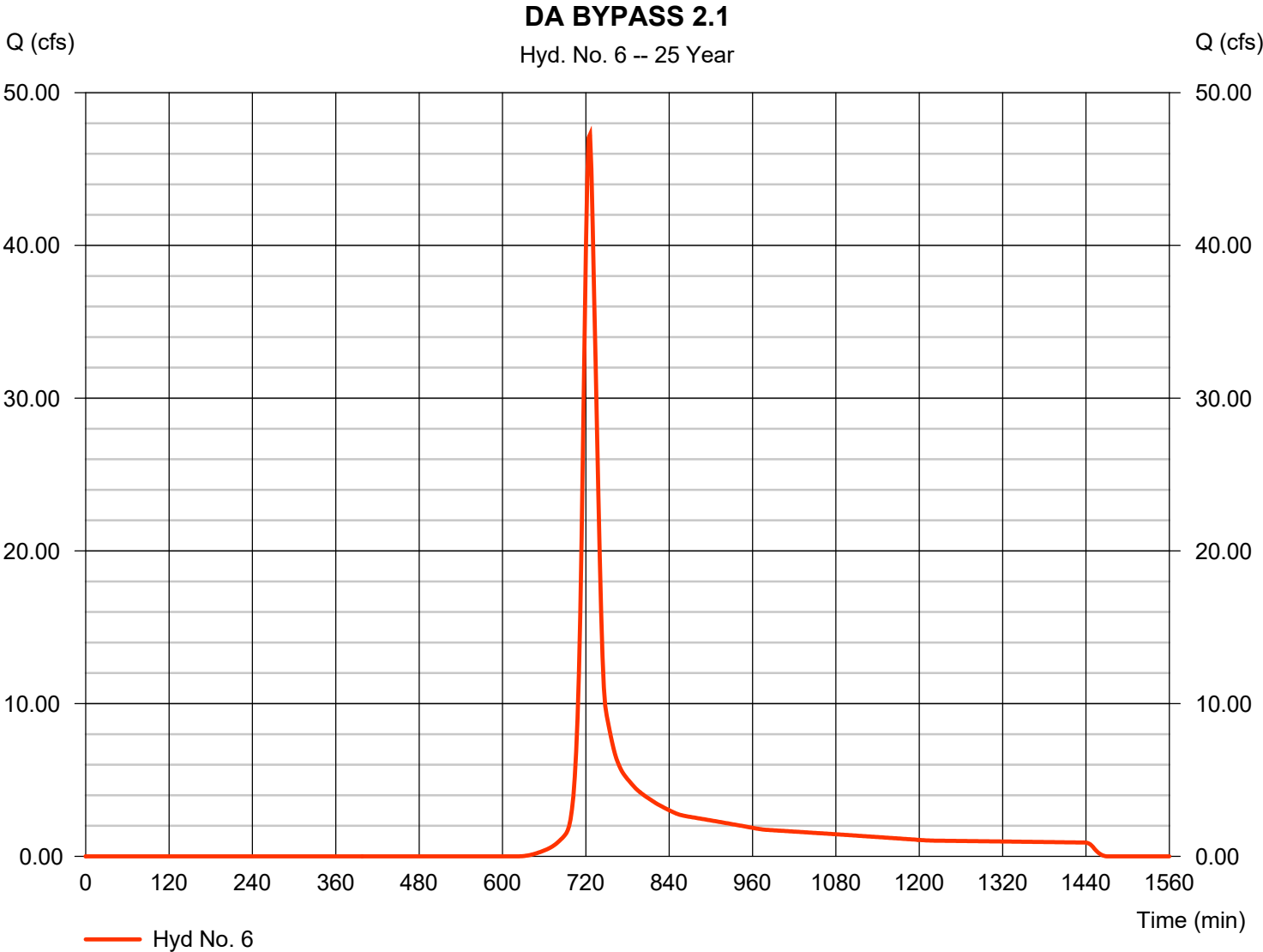



# Hydrograph Report

Hydraflow Hydrographs Extension for AutoCAD® Civil 3D® 2016 by Autodesk, Inc. v11

Thursday, 04 / 26 / 2018

## Hyd. No. 7

Thru Detention Basin#3

Hydrograph type	= Reservoir	Peak discharge	= 32.33 cfs
Storm frequency	= 25 yrs	Time to peak	= 726 min
Time interval	= 2 min	Hyd. volume	= 387,589 cuft
Inflow hyd. No.	= 3 - DA 2.1	Max. Elevation	= 807.99 ft
Reservoir name	= Detention Basin #3	Max. Storage	= 192,060 cuft

Storage Indication method used.

### Thru Detention Basin#3

Hyd. No. 7 -- 25 Year

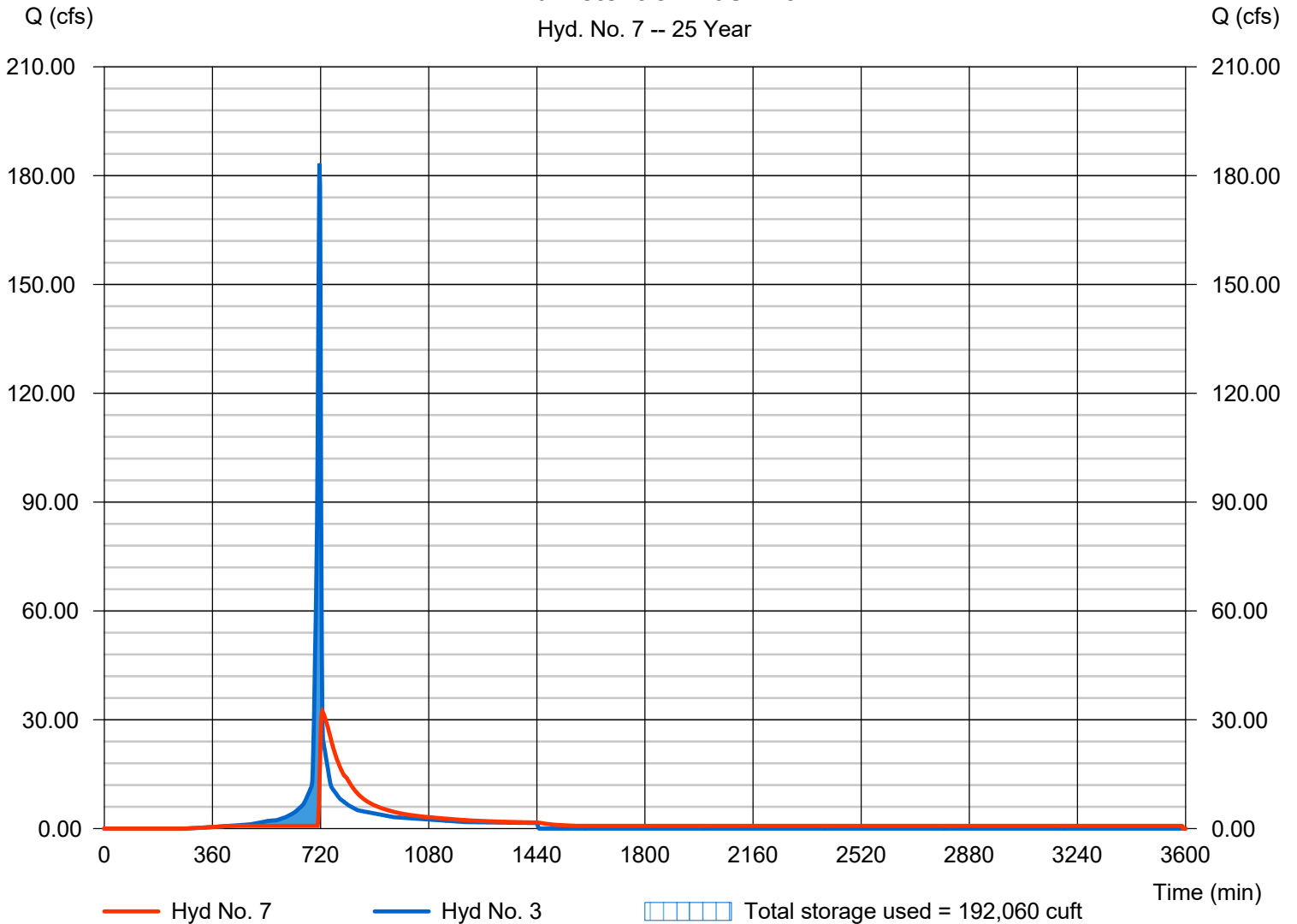

# Hydrograph Report

Hydraflow Hydrographs Extension for AutoCAD® Civil 3D® 2016 by Autodesk, Inc. v11

Thursday, 04 / 26 / 2018

## Hyd. No. 8

Total Post Development DA 2.1

Hydrograph type = Combine  
Storm frequency = 25 yrs  
Time interval = 2 min  
Inflow hyds. = 6, 7

Peak discharge = 79.59 cfs  
Time to peak = 726 min  
Hyd. volume = 540,349 cuft  
Contrib. drain. area = 17.410 ac

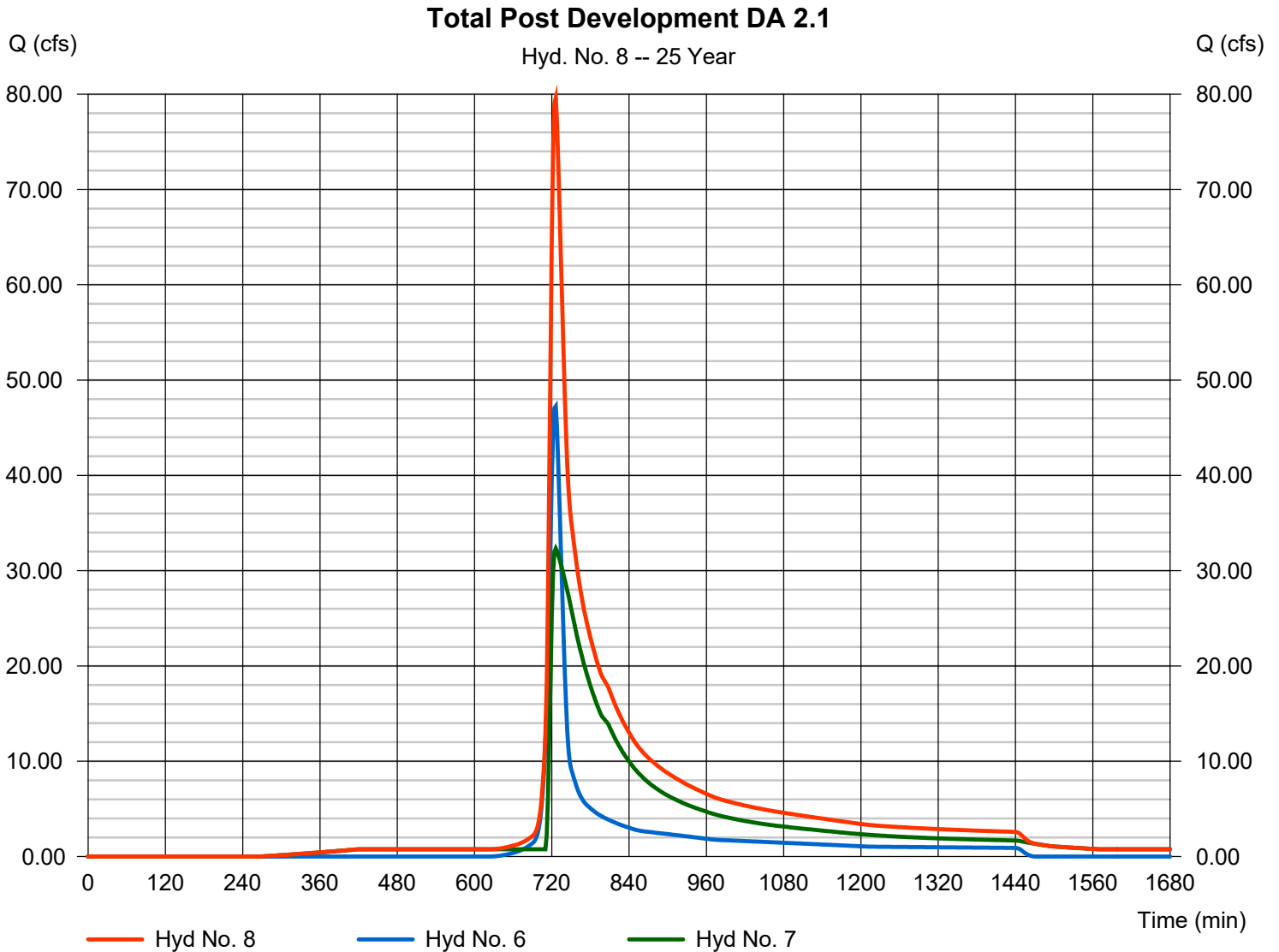

# Hydrograph Summary Report

Hydraflow Hydrographs Extension for AutoCAD® Civil 3D® 2016 by Autodesk, Inc. v11

Hyd. No.	Hydrograph type (origin)	Peak flow (cfs)	Time interval (min)	Time to Peak (min)	Hyd. volume (cuft)	Inflow hyd(s)	Maximum elevation (ft)	Total strge used (cuft)	Hydrograph Description	
1	SCS Runoff	207.53	2	716	454,032	-----	-----	-----	DA 1.1	
2	Reservoir	41.97	2	726	411,091	1	811.22	246,414	Thru Detention Basi #1	
3	SCS Runoff	277.06	2	716	602,339	-----	-----	-----	DA 2.1	
4	SCS Runoff	330.44	2	716	722,942	-----	-----	-----	DA 1.2	
5	Reservoir	37.53	2	734	697,305	4	805.72	401,495	Thru Detention Basin#2	
6	SCS Runoff	91.39	2	724	287,176	-----	-----	-----	DA BYPASS 2.1	
7	Reservoir	156.29	2	722	602,335	3	809.35	261,209	Thru Detention Basin#3	
8	Combine	243.67	2	722	889,511	6, 7	-----	-----	Total Post Development DA 2.1	
16227-Basin Design - 3 Ponds.gpw					Return Period: 100 Year			Thursday, 04 / 26 / 2018		

# Hydrograph Report

Hydraflow Hydrographs Extension for AutoCAD® Civil 3D® 2016 by Autodesk, Inc. v11

Thursday, 04 / 26 / 2018

## Hyd. No. 1

DA 1.1

Hydrograph type = SCS Runoff  
 Storm frequency = 100 yrs  
 Time interval = 2 min  
 Drainage area = 17.340 ac  
 Basin Slope = 0.0 %  
 Tc method = User  
 Total precip. = 9.40 in  
 Storm duration = 24 hrs

Peak discharge = 207.53 cfs  
 Time to peak = 716 min  
 Hyd. volume = 454,032 cuft  
 Curve number = 86  
 Hydraulic length = 0 ft  
 Time of conc. (Tc) = 6.00 min  
 Distribution = Type II  
 Shape factor = 484

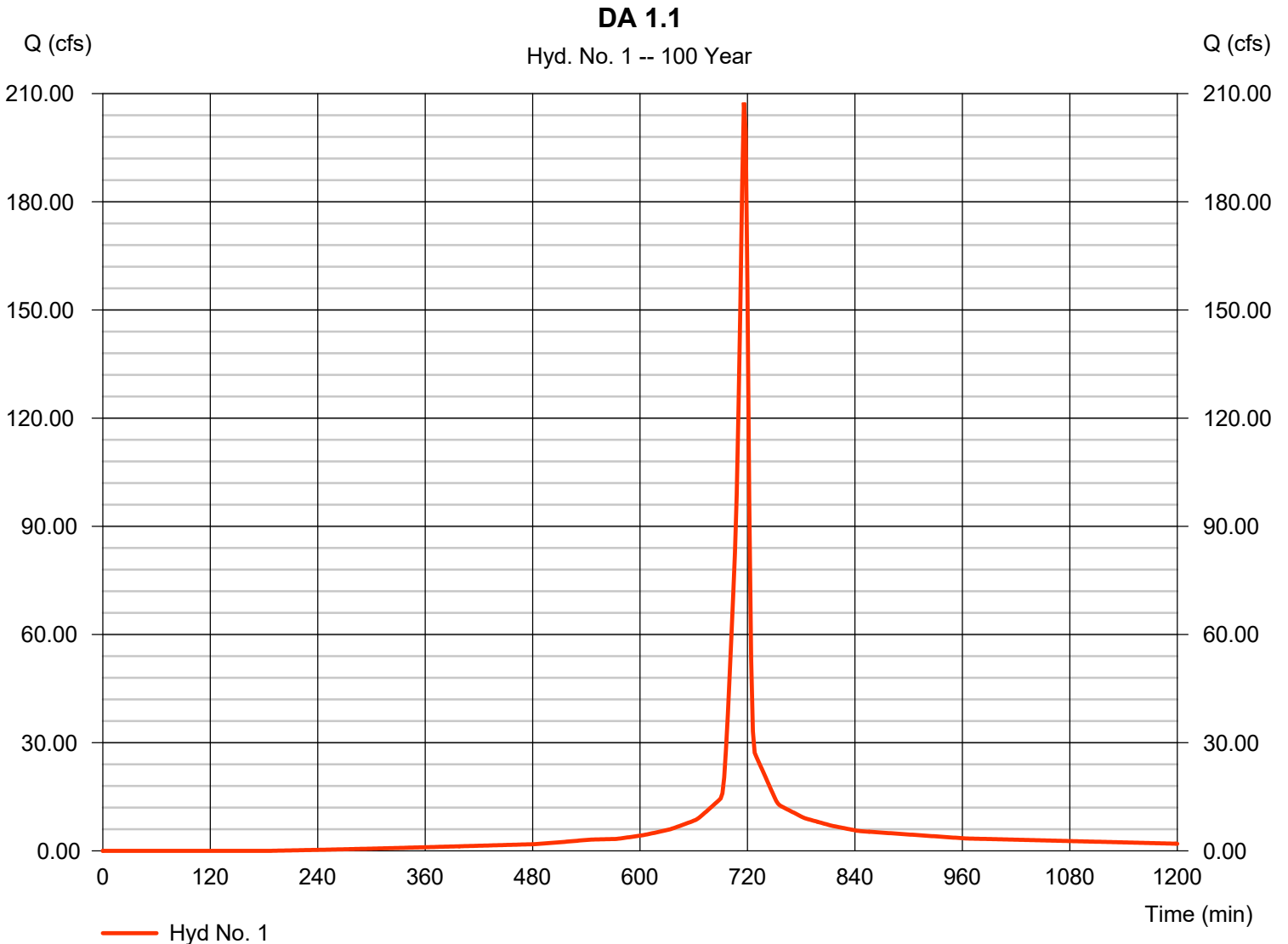

# Hydrograph Report

Hydraflow Hydrographs Extension for AutoCAD® Civil 3D® 2016 by Autodesk, Inc. v11

Thursday, 04 / 26 / 2018

## Hyd. No. 2

Thru Detention Basi #1

Hydrograph type	= Reservoir	Peak discharge	= 41.97 cfs
Storm frequency	= 100 yrs	Time to peak	= 726 min
Time interval	= 2 min	Hyd. volume	= 411,091 cuft
Inflow hyd. No.	= 1 - DA 1.1	Max. Elevation	= 811.22 ft
Reservoir name	= Detention Basin #1	Max. Storage	= 246,414 cuft

Storage Indication method used.

### Thru Detention Basi #1

Hyd. No. 2 -- 100 Year

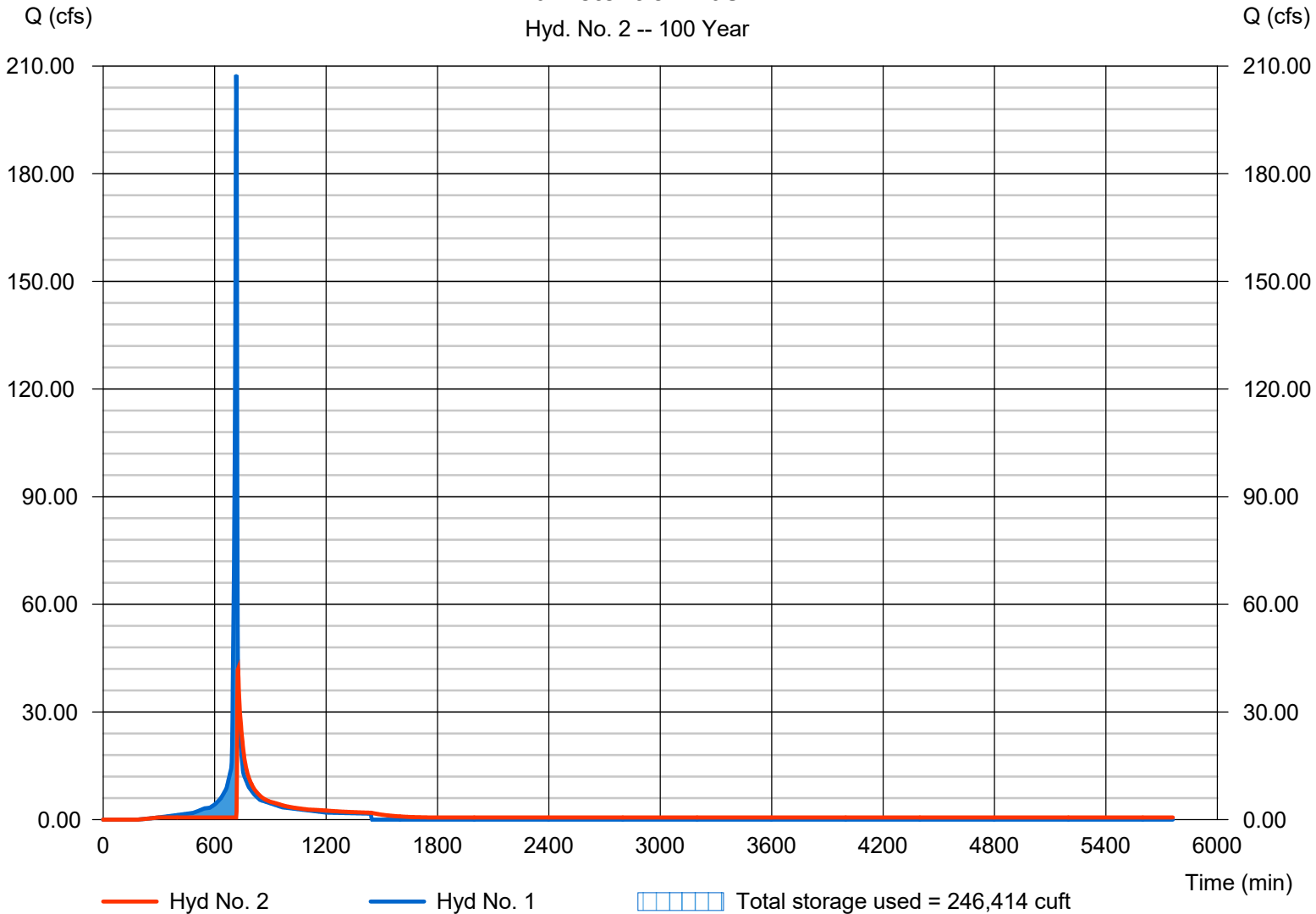

# Hydrograph Report

Hydraflow Hydrographs Extension for AutoCAD® Civil 3D® 2016 by Autodesk, Inc. v11

Thursday, 04 / 26 / 2018

## Hyd. No. 3

DA 2.1

Hydrograph type	= SCS Runoff	Peak discharge	= 277.06 cfs
Storm frequency	= 100 yrs	Time to peak	= 716 min
Time interval	= 2 min	Hyd. volume	= 602,339 cuft
Drainage area	= 23.380 ac	Curve number	= 85
Basin Slope	= 0.0 %	Hydraulic length	= 0 ft
Tc method	= User	Time of conc. (Tc)	= 6.00 min
Total precip.	= 9.40 in	Distribution	= Type II
Storm duration	= 24 hrs	Shape factor	= 484

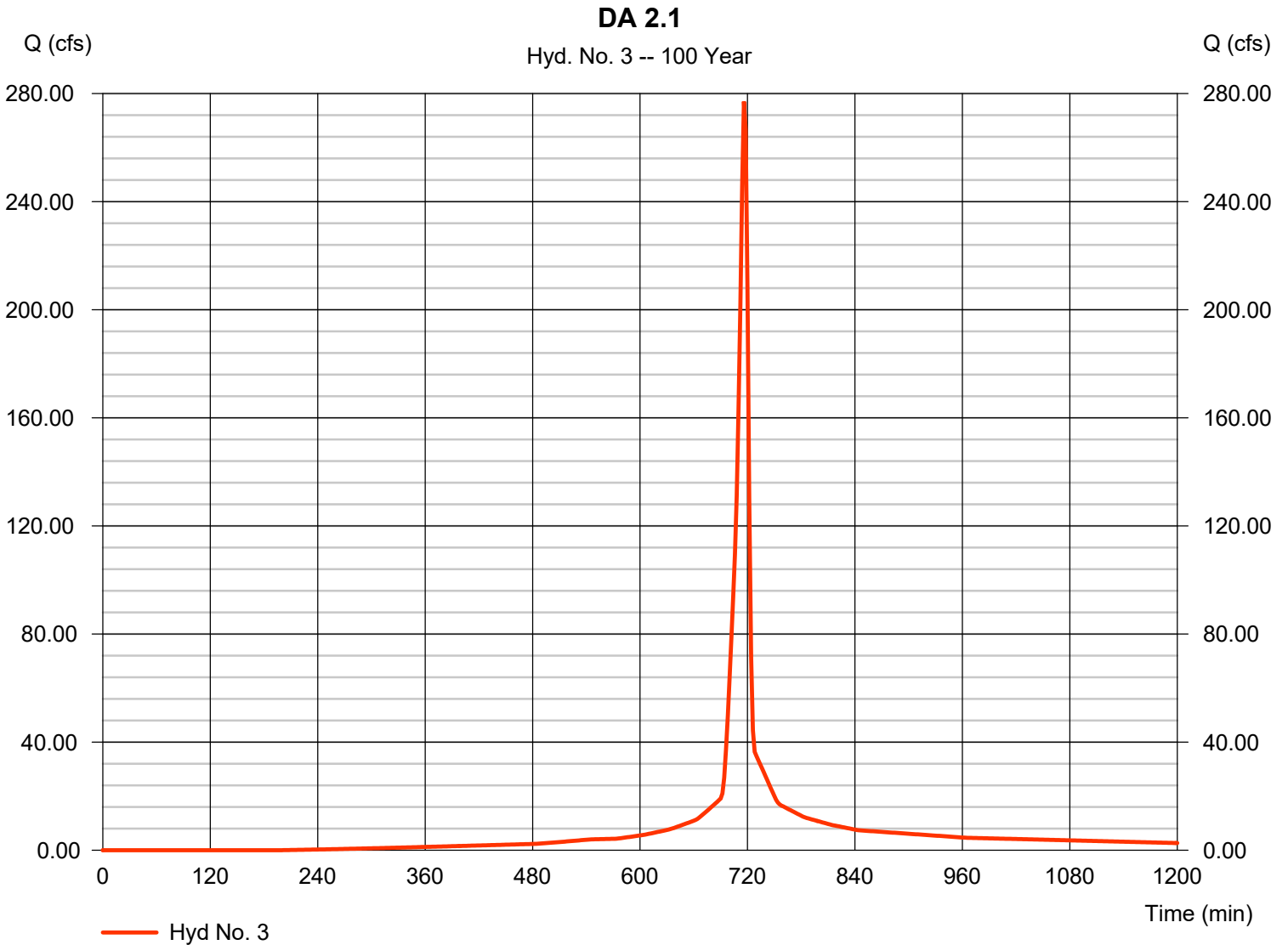

# Hydrograph Report

Hydraflow Hydrographs Extension for AutoCAD® Civil 3D® 2016 by Autodesk, Inc. v11

Thursday, 04 / 26 / 2018

## Hyd. No. 4

DA 1.2

Hydrograph type = SCS Runoff  
 Storm frequency = 100 yrs  
 Time interval = 2 min  
 Drainage area = 27.610 ac  
 Basin Slope = 0.0 %  
 Tc method = User  
 Total precip. = 9.40 in  
 Storm duration = 24 hrs

Peak discharge = 330.44 cfs  
 Time to peak = 716 min  
 Hyd. volume = 722,942 cuft  
 Curve number = 86  
 Hydraulic length = 0 ft  
 Time of conc. (Tc) = 6.00 min  
 Distribution = Type II  
 Shape factor = 484

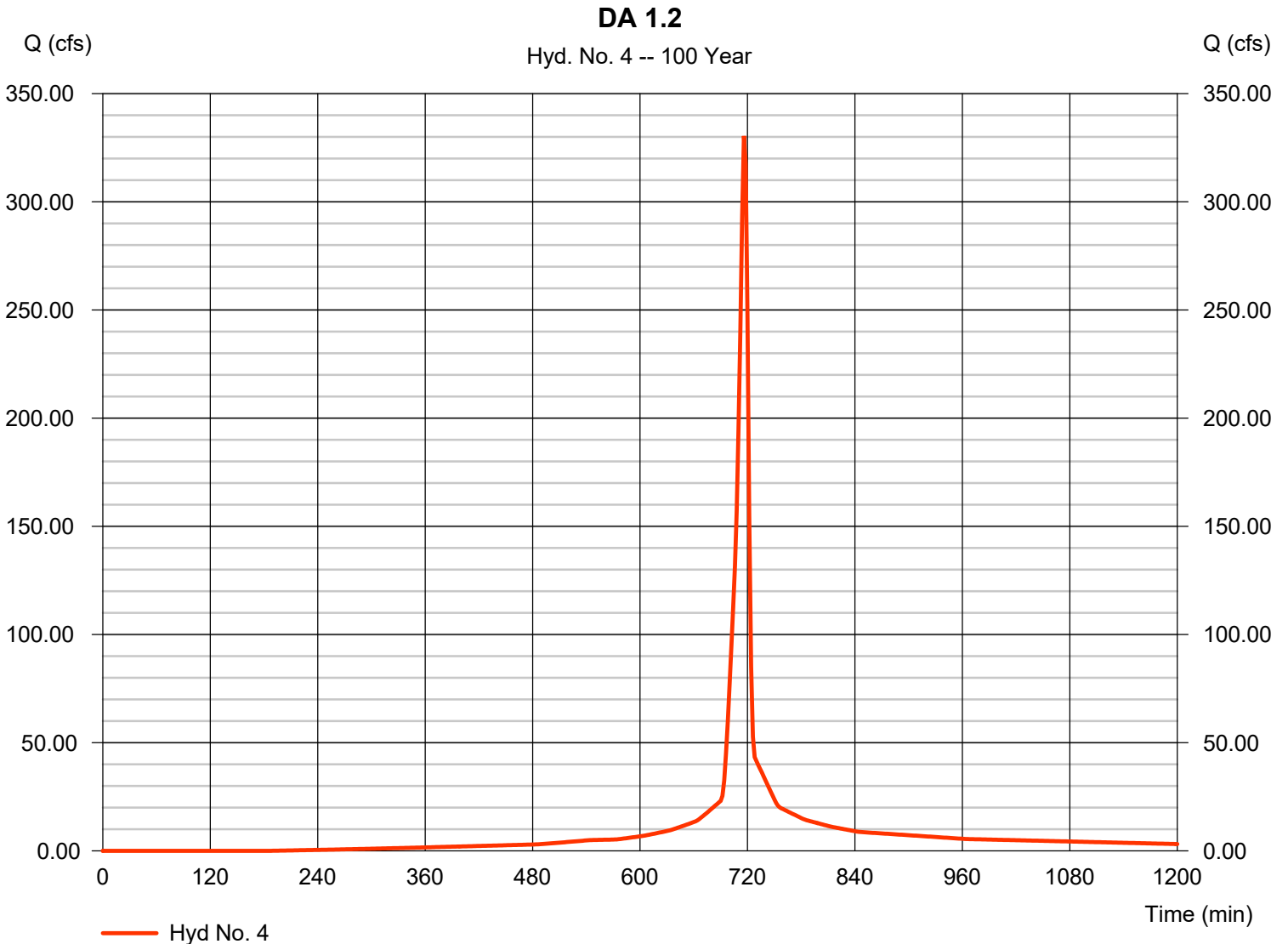

# Hydrograph Report

Hydraflow Hydrographs Extension for AutoCAD® Civil 3D® 2016 by Autodesk, Inc. v11

Thursday, 04 / 26 / 2018

## Hyd. No. 5

Thru Detention Basin#2

Hydrograph type	= Reservoir	Peak discharge	= 37.53 cfs
Storm frequency	= 100 yrs	Time to peak	= 734 min
Time interval	= 2 min	Hyd. volume	= 697,305 cuft
Inflow hyd. No.	= 4 - DA 1.2	Max. Elevation	= 805.72 ft
Reservoir name	= Detention Basin #2	Max. Storage	= 401,495 cuft

Storage Indication method used.

### Thru Detention Basin#2

Hyd. No. 5 -- 100 Year

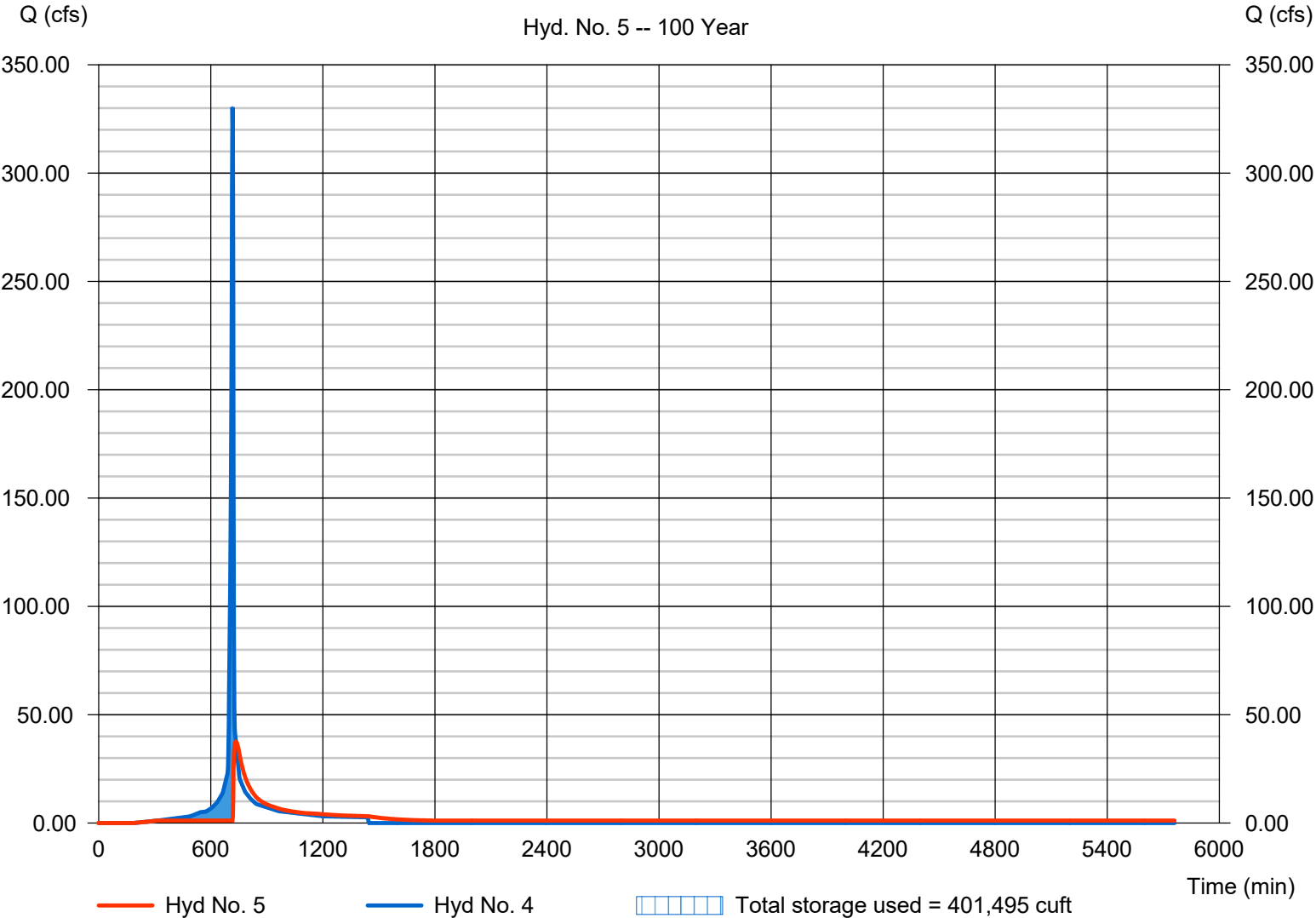



# Hydrograph Report

## Hyd. No. 6

### DA BYPASS 2.1

Hydrograph type	= SCS Runoff	Peak discharge	= 91.39 cfs
Storm frequency	= 100 yrs	Time to peak	= 724 min
Time interval	= 2 min	Hyd. volume	= 287,176 cuft
Drainage area	= 17.410 ac	Curve number	= 61
Basin Slope	= 0.0 %	Hydraulic length	= 0 ft
Tc method	= TR55	Time of conc. (Tc)	= 17.40 min
Total precip.	= 9.40 in	Distribution	= Type II
Storm duration	= 24 hrs	Shape factor	= 484

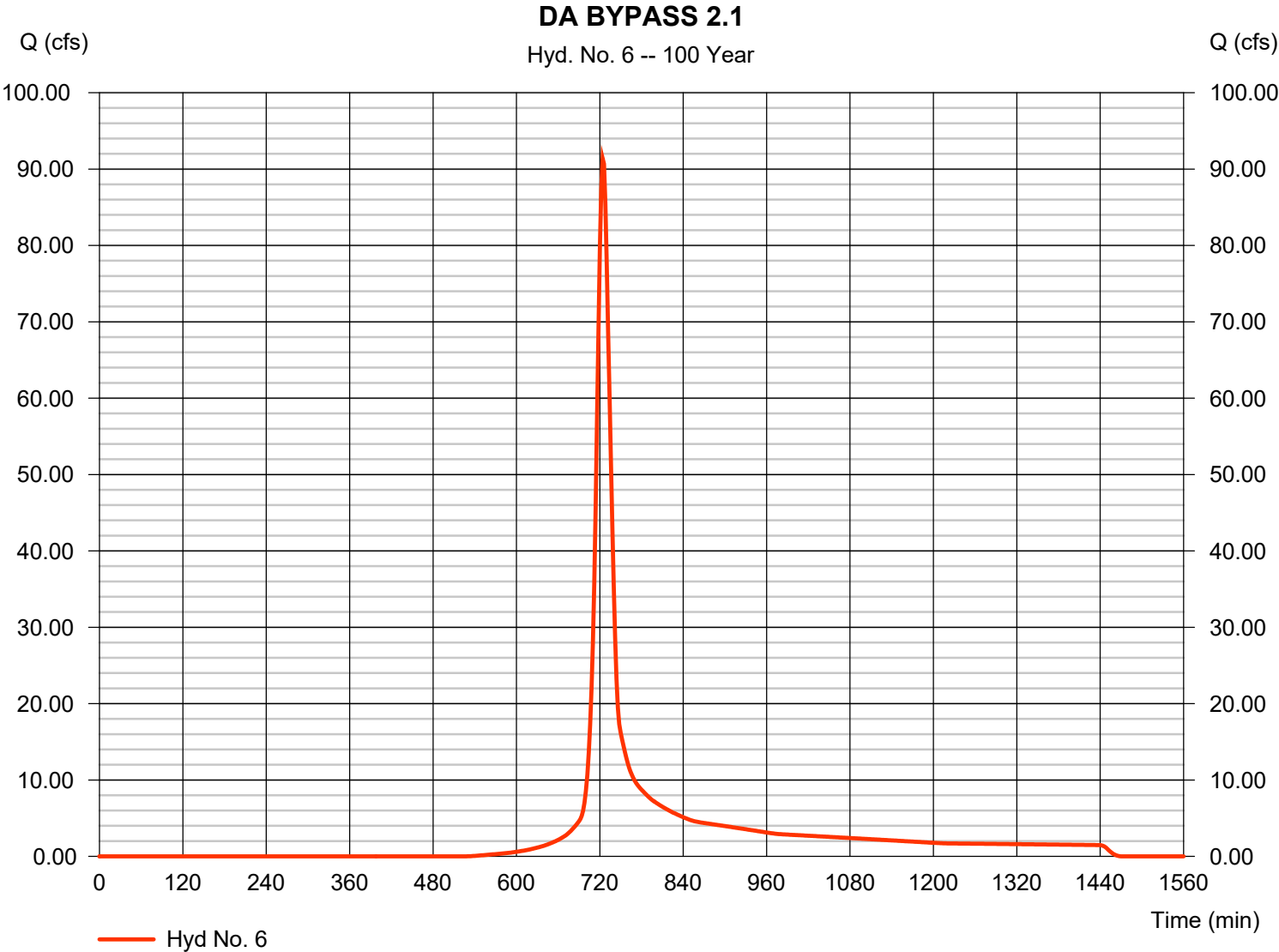

# Hydrograph Report

Hydraflow Hydrographs Extension for AutoCAD® Civil 3D® 2016 by Autodesk, Inc. v11

Thursday, 04 / 26 / 2018

## Hyd. No. 7

Thru Detention Basin#3

Hydrograph type	= Reservoir	Peak discharge	= 156.29 cfs
Storm frequency	= 100 yrs	Time to peak	= 722 min
Time interval	= 2 min	Hyd. volume	= 602,335 cuft
Inflow hyd. No.	= 3 - DA 2.1	Max. Elevation	= 809.35 ft
Reservoir name	= Detention Basin #3	Max. Storage	= 261,209 cuft

Storage Indication method used.

### Thru Detention Basin#3

Hyd. No. 7 -- 100 Year

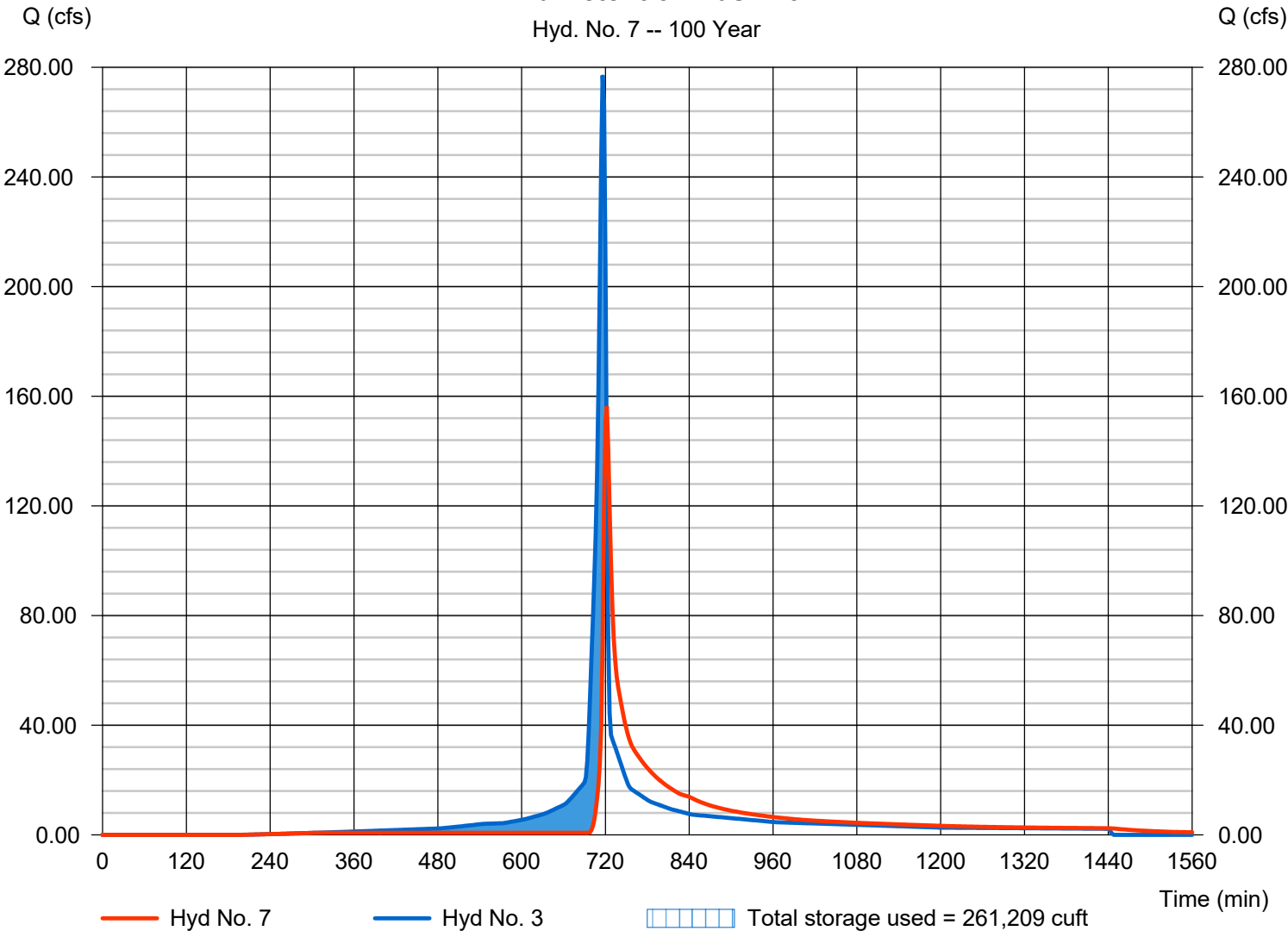

# Hydrograph Report

Hydraflow Hydrographs Extension for AutoCAD® Civil 3D® 2016 by Autodesk, Inc. v11

Thursday, 04 / 26 / 2018

## Hyd. No. 8

Total Post Development DA 2.1

Hydrograph type = Combine  
Storm frequency = 100 yrs  
Time interval = 2 min  
Inflow hyds. = 6, 7

Peak discharge = 243.67 cfs  
Time to peak = 722 min  
Hyd. volume = 889,511 cuft  
Contrib. drain. area = 17.410 ac

### Total Post Development DA 2.1

Hyd. No. 8 -- 100 Year

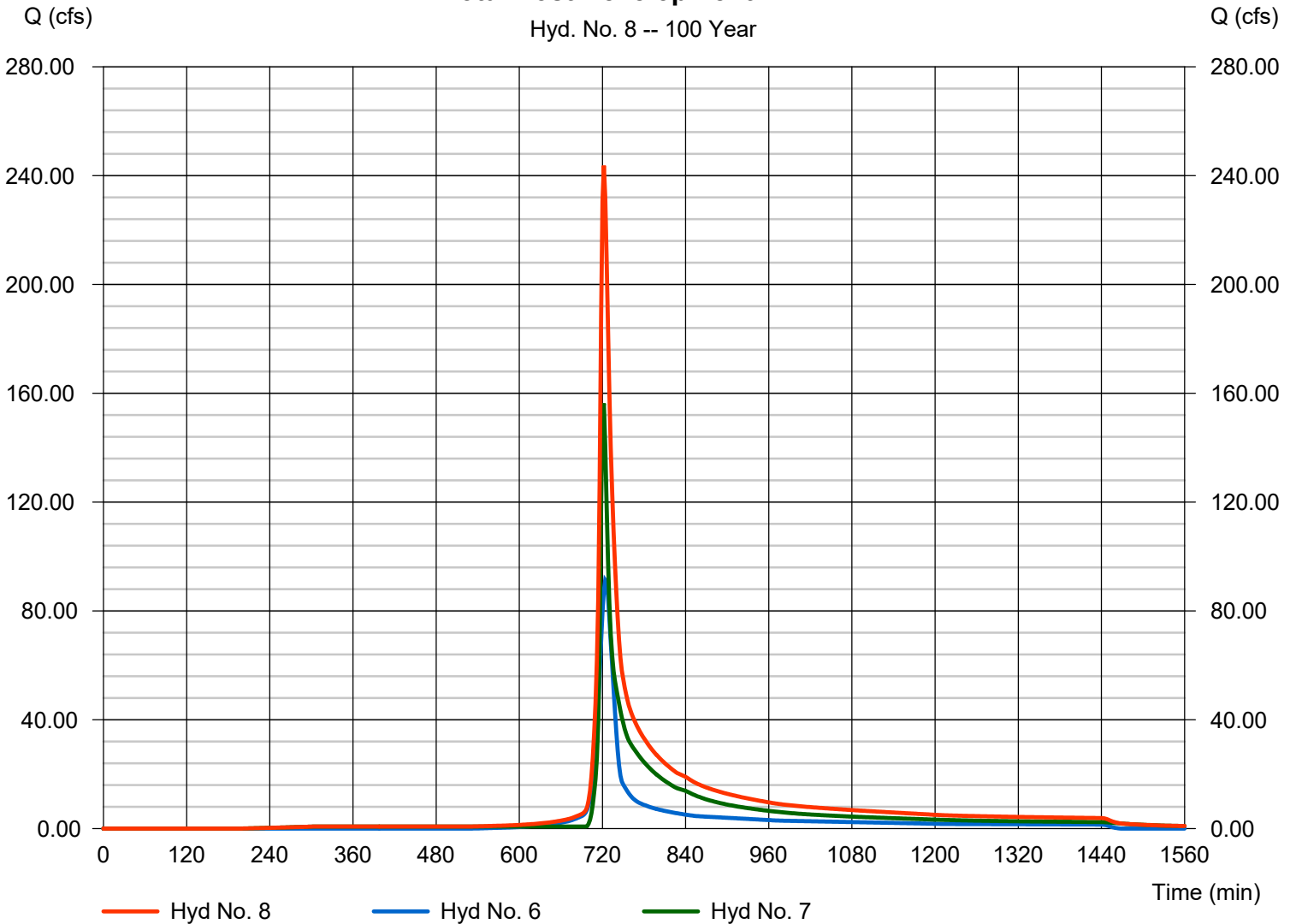



**APPENDIX E      Perimeter Drainage, Slope Conveyance, and Storm Drainage Pipes**

**-Cell 1**

**Perimeter Drainage Ditch Map**

**Slope Conveyance Map**

**Hydraflow Express Extension**

**-Cell 2**

**Perimeter Drainage Ditch Map**

**Slope Conveyance Map**

**Hydraflow Express Extension**

**-Storm and Sanitary Analysis**

# STORM DRAINAGE PIPE REPORT

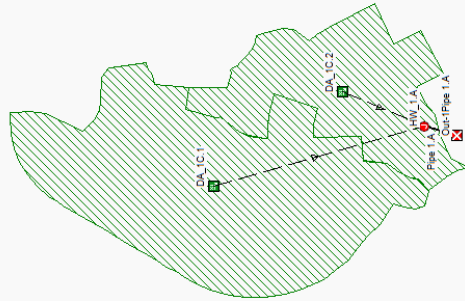
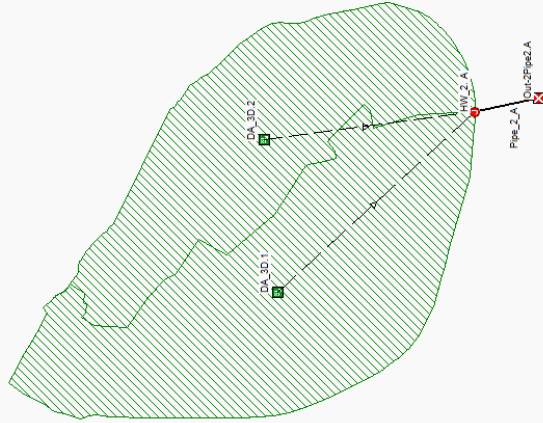

\*\*\*\*\*  
 Project Description  
 \*\*\*\*\*

File Name ..... GP Landfill Pipes.SPF

\*\*\*\*\*  
 Analysis Options  
 \*\*\*\*\*

Flow Units ..... cfs  
 Subbasin Hydrograph Method. EPA SWMM  
 Infiltration Method ..... SCS Curve Number  
 Link Routing Method ..... Kinematic Wave  
 Storage Node Exfiltration.. None  
 Starting Date ..... APR-13-2018 00:00:00  
 Ending Date ..... APR-14-2018 00:00:00  
 Antecedent Dry Days ..... 0.0  
 Report Time Step ..... 00:05:00  
 Wet Time Step ..... 00:05:00  
 Dry Time Step ..... 01:00:00  
 Routing Time Step ..... 30.00 sec

\*\*\*\*\*  
 Element Count  
 \*\*\*\*\*

Number of rain gages ..... 1  
 Number of subbasins ..... 4  
 Number of nodes ..... 4  
 Number of links ..... 2  
 Number of pollutants ..... 0  
 Number of land uses ..... 0

\*\*\*\*\*  
 Raingage Summary  
 \*\*\*\*\*

Gage ID	Data Source	Data Type	Recording Interval
Rain Gage-01	10-Yr	CUMULATIVE	6.00 min

\*\*\*\*\*  
 Subbasin Summary  
 \*\*\*\*\*

Subbasin ID	Total Area acres	Equiv. Width ft	Imperv. Area %	Average Slope %	Raingage
DA_1C.1	8.53	500.00	25.00	0.5000	Rain Gage-01
DA_1C.2	3.78	500.00	25.00	0.5000	Rain Gage-01
DA_3D.1	12.07	500.00	25.00	0.5000	Rain Gage-01
DA_3D.2	8.34	500.00	25.00	0.5000	Rain Gage-01

\*\*\*\*\*  
 Node Summary  
 \*\*\*\*\*

Node ID	Element Type	Invert Elevation ft	Maximum Elev. ft	Ponded Area ft <sup>2</sup>	External Inflow
---------	--------------	---------------------	------------------	-----------------------------	-----------------

```

-----
HW_1.A          JUNCTION          816.90    819.90    0.00
HW_2. A        JUNCTION          808.95    811.70    0.00
Out-1Pipe 1.A  OUTFALL          816.00    819.00    0.00
Out-2Pipe2.A   OUTFALL          805.00    807.00    0.00

```

```

*****
Link Summary
*****

```

Link ID	From Node	To Node	Element Type	Length ft	Slope %	Manning's Roughness
Pipe 1.A	HW_1.A	Out-1Pipe 1.A	CONDUIT	170.9	0.5267	0.0130
Pipe_2_A	HW_2. A	Out-2Pipe2.A	CONDUIT	29.1	13.5512	0.0130

```

*****
Cross Section Summary
*****

```

Link Design ID Flow Capacity	Shape	Depth/Diameter ft	Width ft	No. of Barrels	Cross Sectional Area ft <sup>2</sup>	Full Flow Hydraulic Radius ft
Pipe 1.A	CIRCULAR	3.00	3.00	1	7.07	0.75
Pipe_2_A	CIRCULAR	2.00	2.00	1	3.14	0.50

```

-----
Pipe 1.A          CIRCULAR          3.00    3.00    1    7.07    0.75
48.41
Pipe_2_A         CIRCULAR          2.00    2.00    1    3.14    0.50
83.28

```

```

*****
Runoff Quantity Continuity
*****
Volume      Depth
acre-ft     inches
-----
Total Precipitation ..... 14.993    5.499
Evaporation Loss ..... 0.000    0.000
Infiltration Loss ..... 2.569    0.942
Surface Runoff ..... 11.632    4.266
Final Surface Storage ... 0.813    0.298
Continuity Error (%) ..... -0.138

```

```

*****
Flow Routing Continuity
*****
Volume      Volume
acre-ft     Mgallons
-----
Dry Weather Inflow ..... 0.000    0.000
Wet Weather Inflow ..... 11.618    3.786
Groundwater Inflow ..... 0.000    0.000
RDII Inflow ..... 0.000    0.000
External Inflow ..... 0.000    0.000
External Outflow ..... 11.614    3.785
Surface Flooding ..... 0.000    0.000
Evaporation Loss ..... 0.000    0.000
Initial Stored Volume ... 0.000    0.000
Final Stored Volume ..... 0.001    0.000
Continuity Error (%) ..... 0.023

```

```

*****
Composite Curve Number Computations Report
*****

```



-----  
 Subbasin DA\_1C.1  
 -----

Soil/Surface Description	Area (acres)	Soil Group	CN
Newly Graded, Fair Condition (HSG B)	8.53	B	86.00
Composite Area & Weighted CN	8.53		86.00

-----  
 Subbasin DA\_1C.2  
 -----

Soil/Surface Description	Area (acres)	Soil Group	CN
Newly Graded, Fair Condition (HSG B)	3.78	B	86.00
Composite Area & Weighted CN	3.78		86.00

-----  
 Subbasin DA\_3D.1  
 -----

Soil/Surface Description	Area (acres)	Soil Group	CN
Newly Graded, Fair Condition (HSG B)	12.07	B	86.00
Composite Area & Weighted CN	12.07		86.00

-----  
 Subbasin DA\_3D.2  
 -----

Soil/Surface Description	Area (acres)	Soil Group	CN
Newly Graded, Fair Condition (HSG B)	8.34	B	86.00
Composite Area & Weighted CN	8.34		86.00

\*\*\*\*\*  
 EPA SWMM Time of Concentration Computations Report  
 \*\*\*\*\*

$$T_c = (0.94 * (L^{0.6}) * (n^{0.6})) / ((i^{0.4}) * (S^{0.3}))$$

Where:

- Tc = Time of Concentration (min)
- L = Flow Length (ft)
- n = Manning's Roughness
- i = Rainfall Intensity (in/hr)
- S = Slope (ft/ft)

-----  
 Subbasin DA\_1C.1  
 -----

Flow length (ft):	743.44
Pervious Manning's Roughness:	0.10000
Impervious Manning's Roughness:	0.01500
Pervious Rainfall Intensity (in/hr):	0.22912
Impervious Rainfall Intensity (in/hr):	0.22912
Slope (%):	0.50000
Computed TOC (minutes):	92.75

-----  
 Subbasin DA\_1C.2  
 -----

```

Flow length (ft):                329.12
Pervious Manning's Roughness:    0.10000
Impervious Manning's Roughness:  0.01500
Pervious Rainfall Intensity (in/hr): 0.22912
Impervious Rainfall Intensity (in/hr): 0.22912
Slope (%):                        0.50000
Computed TOC (minutes):          56.88

```

-----  
Subbasin DA\_3D.1  
-----

```

Flow length (ft):                1051.65
Pervious Manning's Roughness:    0.10000
Impervious Manning's Roughness:  0.01500
Pervious Rainfall Intensity (in/hr): 0.22912
Impervious Rainfall Intensity (in/hr): 0.22912
Slope (%):                        0.50000
Computed TOC (minutes):          114.21

```

-----  
Subbasin DA\_3D.2  
-----

```

Flow length (ft):                726.30
Pervious Manning's Roughness:    0.10000
Impervious Manning's Roughness:  0.01500
Pervious Rainfall Intensity (in/hr): 0.22912
Impervious Rainfall Intensity (in/hr): 0.22912
Slope (%):                        0.50000
Computed TOC (minutes):          91.46

```

\*\*\*\*\*  
Subbasin Runoff Summary  
\*\*\*\*\*

Subbasin Time of ID Concentration hh:mm:ss	Total Rainfall in	Total Runon in	Total Evap. in	Total Infil. in	Total Runoff in	Peak Runoff cfs	Runoff Coefficient	days
DA_1C.1 01:32:45	5.50	0.00	0.00	0.94	4.27	29.39	0.777	0
DA_1C.2 00:56:53	5.50	0.00	0.00	0.94	4.32	16.72	0.786	0
DA_3D.1 01:54:12	5.50	0.00	0.00	0.94	4.24	37.25	0.771	0
DA_3D.2 01:31:27	5.50	0.00	0.00	0.94	4.27	28.92	0.777	0

\*\*\*\*\*  
Node Depth Summary  
\*\*\*\*\*

Node ID	Average Depth Attained ft	Maximum Depth Attained ft	Maximum HGL Attained ft	Time of Max Occurrence days hh:mm	Total Flooded Volume acre-in	Total Time Flooded minutes	Retention Time hh:mm:ss
HW_1.A	0.34	2.34	819.24	0 12:00	0	0	0:00:00
HW_2. A	0.22	1.35	810.30	0 12:06	0	0	0:00:00
Out-1Pipe 1.A	0.34	2.33	818.33	0 12:00	0	0	0:00:00
Out-2Pipe2.A	0.22	1.35	806.35	0 12:06	0	0	0:00:00

\*\*\*\*\*  
Node Flow Summary  
\*\*\*\*\*

Node ID	Element Type	Maximum Lateral Inflow cfs	Peak Inflow cfs	Time of Peak Inflow Occurrence days hh:mm	Maximum Flooding Overflow cfs	Time of Peak Flooding Occurrence days hh:mm
HW_1.A	JUNCTION	45.99	45.99	0 12:00	0.00	
HW_2. A	JUNCTION	66.17	66.17	0 12:06	0.00	
Out-1Pipe 1.A	OUTFALL	0.00	45.95	0 12:00	0.00	
Out-2Pipe2.A	OUTFALL	0.00	66.16	0 12:06	0.00	

\*\*\*\*\*  
Outfall Loading Summary  
\*\*\*\*\*

Outfall Node ID	Flow Frequency (%)	Average Flow cfs	Peak Inflow cfs
Out-1Pipe 1.A	99.17	2.23	45.95
Out-2Pipe2.A	99.48	3.66	66.16
System	99.32	5.89	111.52

\*\*\*\*\*  
Link Flow Summary  
\*\*\*\*\*

Link ID	Element Reported Type	Time of Peak Flow Occurrence days hh:mm	Maximum Velocity Attained ft/sec	Length Factor	Peak Flow during Analysis cfs	Design Flow Capacity cfs	Ratio of Maximum /Design Flow
Pipe 1.A 0.78	CONDUIT Calculated	0 12:00	7.86	1.00	45.95	48.41	0.95
Pipe_2_A 0.67	CONDUIT Calculated	0 12:06	29.41	1.00	66.16	83.28	0.79

\*\*\*\*\*  
Highest Flow Instability Indexes  
\*\*\*\*\*  
Link Pipe\_2\_A (1)

\*\*\*\*\*  
Routing Time Step Summary  
\*\*\*\*\*  
Minimum Time Step : 30.00 sec  
Average Time Step : 30.00 sec  
Maximum Time Step : 30.00 sec  
Percent in Steady State : 0.00  
Average Iterations per Step : 1.25

WARNING 002 : Max/rim elevation (depth) increased to account for connecting conduit height dimensions for Node HW\_1.A.

Analysis began on: Fri Apr 27 11:18:52 2018  
Analysis ended on: Fri Apr 27 11:18:53 2018  
Total elapsed time: 00:00:01

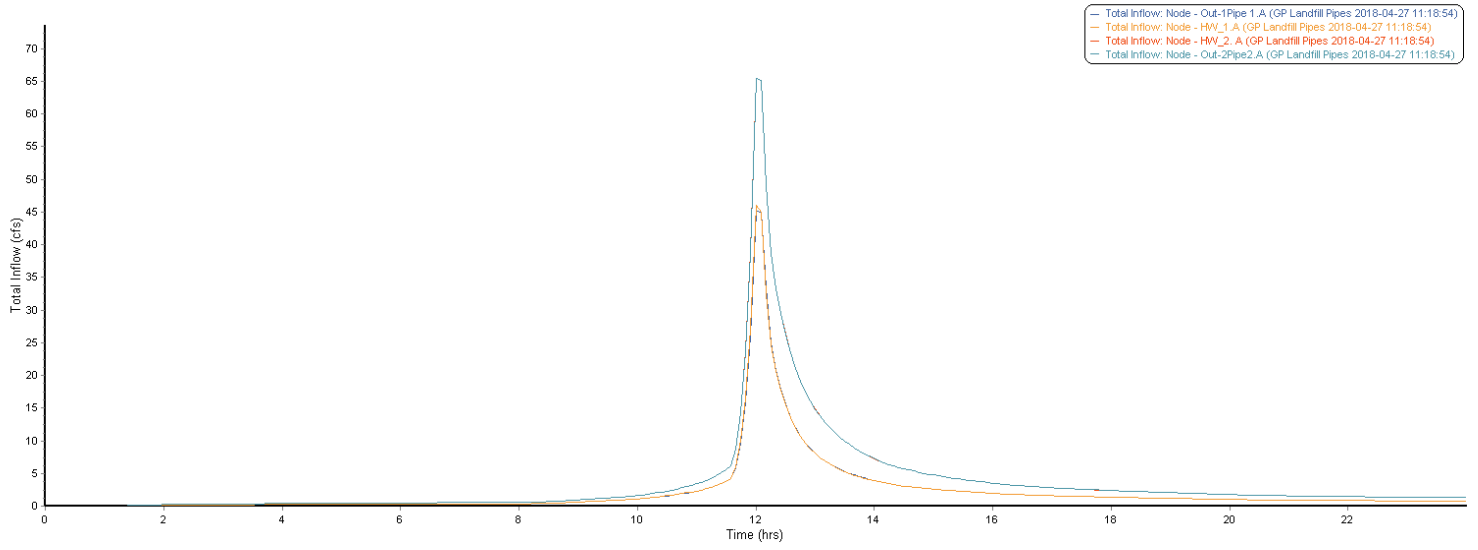

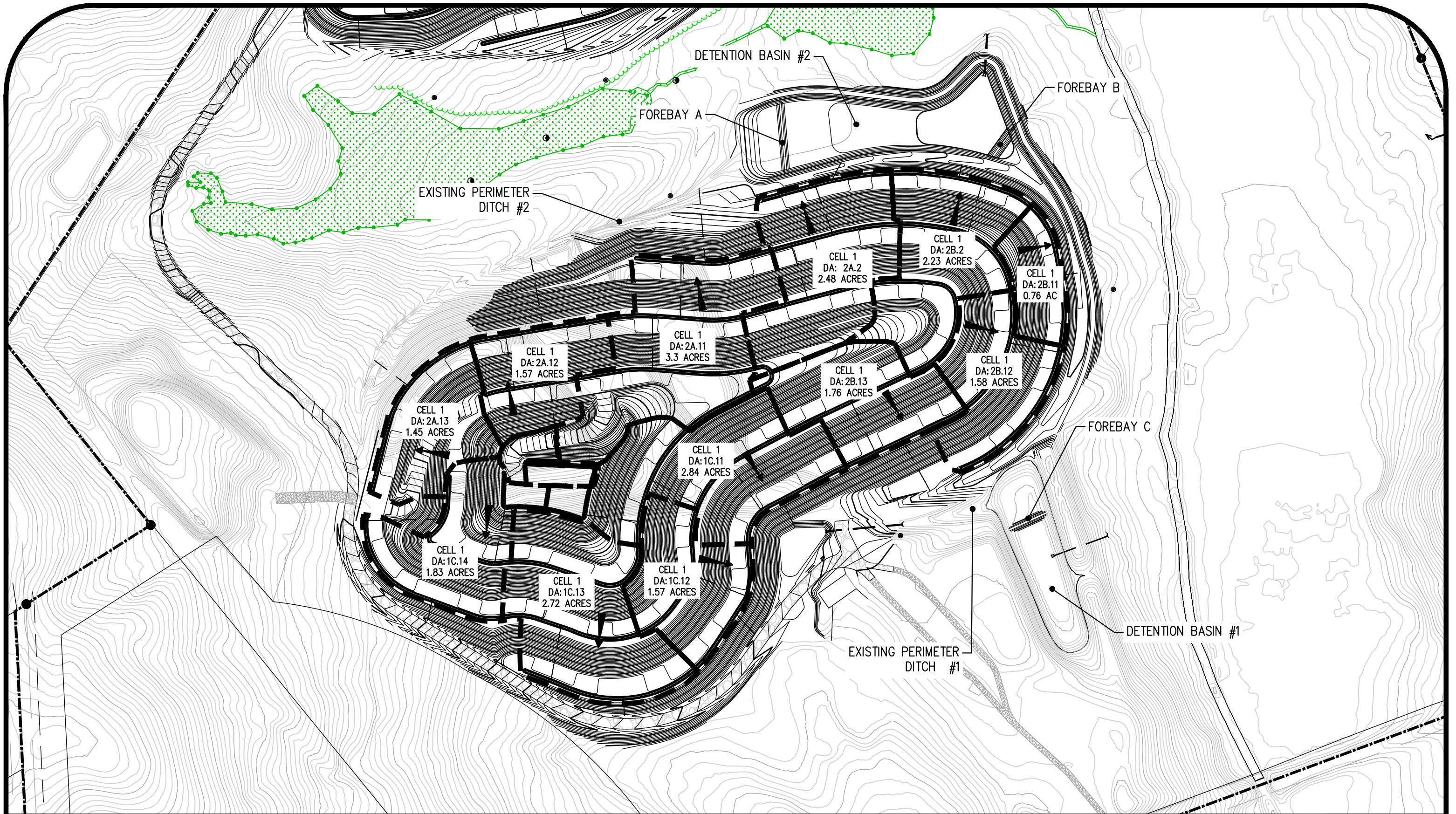

Documents prepared or furnished by Alliance Consulting Engineers, Inc. are instruments of service, and Alliance Consulting Engineers, Inc. retains an ownership and property interest (including the copyright and the right of reuse) in such documents, whether or not the project is completed.

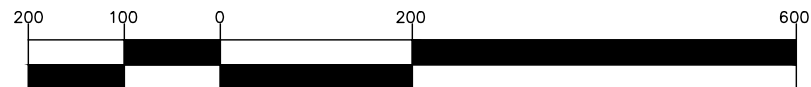

( IN FEET )

Project No.: 16227-0004  
March, 2018

## Slope Conveyance Drainage Map - Cell 1 for Project Greenpointe Landfill in Anderson County, South Carolina



Prepared by Alliance Consulting Engineers, Inc.  
124 Verdae Blvd, Greenville, SC 29607-3843  
864-284-1740  
www.alliancece.com

# Channel Report

## SLOPE CONVEYANCE DRAINAGE - CELL 1

### Trapezoidal

Bottom Width (ft) = 2.00  
Side Slopes (z:1) = 1.00, 1.00  
Total Depth (ft) = 2.00  
Invert Elev (ft) = 100.00  
Slope (%) = 1.00  
N-Value = 0.030

### Highlighted

Depth (ft) = 1.08  
Q (cfs) = 12.28  
Area (sqft) = 3.33  
Velocity (ft/s) = 3.69  
Wetted Perim (ft) = 5.05  
Crit Depth,  $Y_c$  (ft) = 0.91  
Top Width (ft) = 4.16  
EGL (ft) = 1.29

### Calculations

Compute by: Known Q  
Known Q (cfs) = 12.28

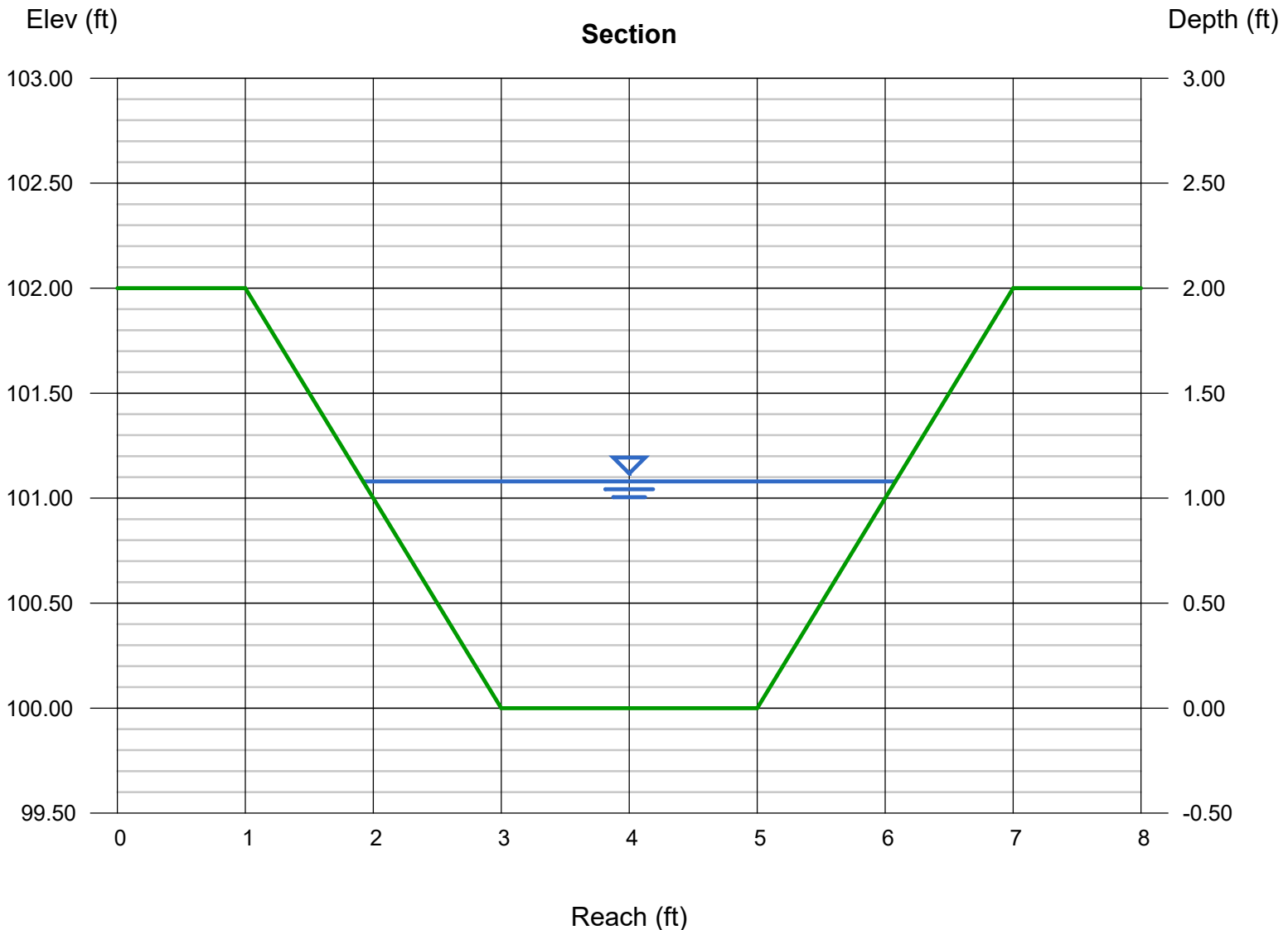

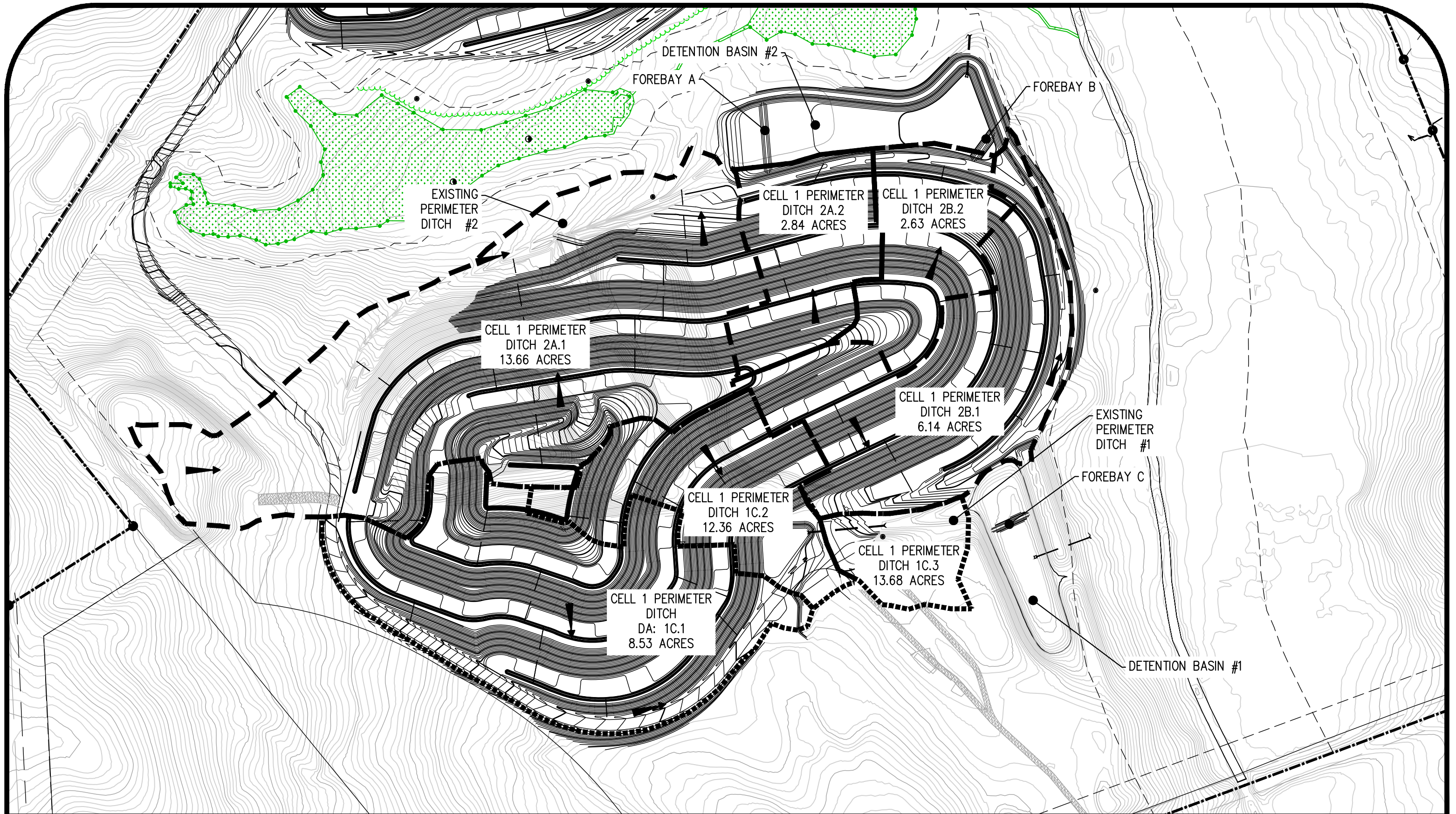

Documents prepared or furnished by Alliance Consulting Engineers, Inc. are instruments of service, and Alliance Consulting Engineers, Inc. retains an ownership and property interest (including the copyright and the right of reuse) in such documents, whether or not the project is completed.

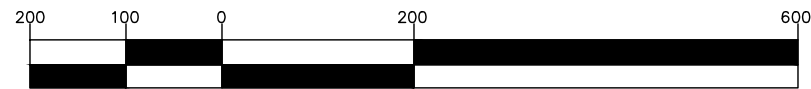

( IN FEET )

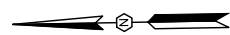

## Perimeter Drainage Ditch Map - Cell 1 for Project Greenpoint Landfill in Anderson County, South Carolina

Project No.: 16227-0004  
March, 2018



Prepared by Alliance Consulting Engineers, Inc.  
124 Verdae Blvd, Greenville, SC 29607-3843  
864-284-1740  
www.allianceCE.com



# Channel Report

## PERIMETER DRAINAGE DITCH - CELL 1 - PERIMETER DITCH 2A.1 (EXISTING DITCH 2)

### Trapezoidal

Bottom Width (ft)	= 4.00
Side Slopes (z:1)	= 3.00, 3.00
Total Depth (ft)	= 3.00
Invert Elev (ft)	= 100.00
Slope (%)	= 4.10
N-Value	= 0.030

### Highlighted

Depth (ft)	= 0.97
Q (cfs)	= 50.84
Area (sqft)	= 6.70
Velocity (ft/s)	= 7.59
Wetted Perim (ft)	= 10.13
Crit Depth, Yc (ft)	= 1.26
Top Width (ft)	= 9.82
EGL (ft)	= 1.86

### Calculations

Compute by:	Known Q
Known Q (cfs)	= 50.84

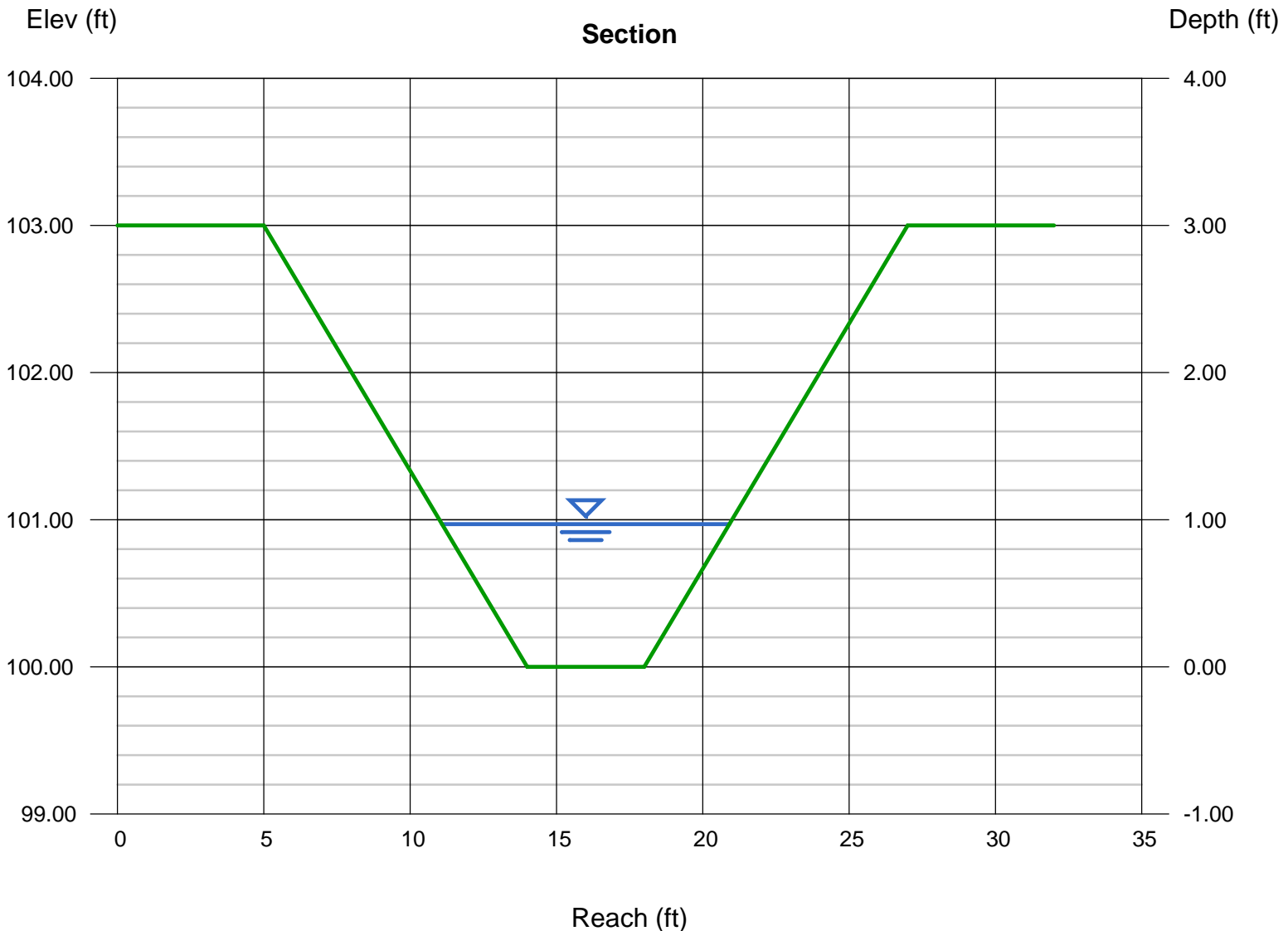

# Channel Report

## PERIMETER DRAINAGE DITCH - CELL 1 - PERIMETER DITCH 2A.2

### Trapezoidal

Bottom Width (ft) = 2.00  
Side Slopes (z:1) = 3.00, 3.00  
Total Depth (ft) = 1.50  
Invert Elev (ft) = 100.00  
Slope (%) = 1.00  
N-Value = 0.030

### Highlighted

Depth (ft) = 0.79  
Q (cfs) = 10.57  
Area (sqft) = 3.45  
Velocity (ft/s) = 3.06  
Wetted Perim (ft) = 7.00  
Crit Depth, Yc (ft) = 0.69  
Top Width (ft) = 6.74  
EGL (ft) = 0.94

### Calculations

Compute by: Known Q  
Known Q (cfs) = 10.57

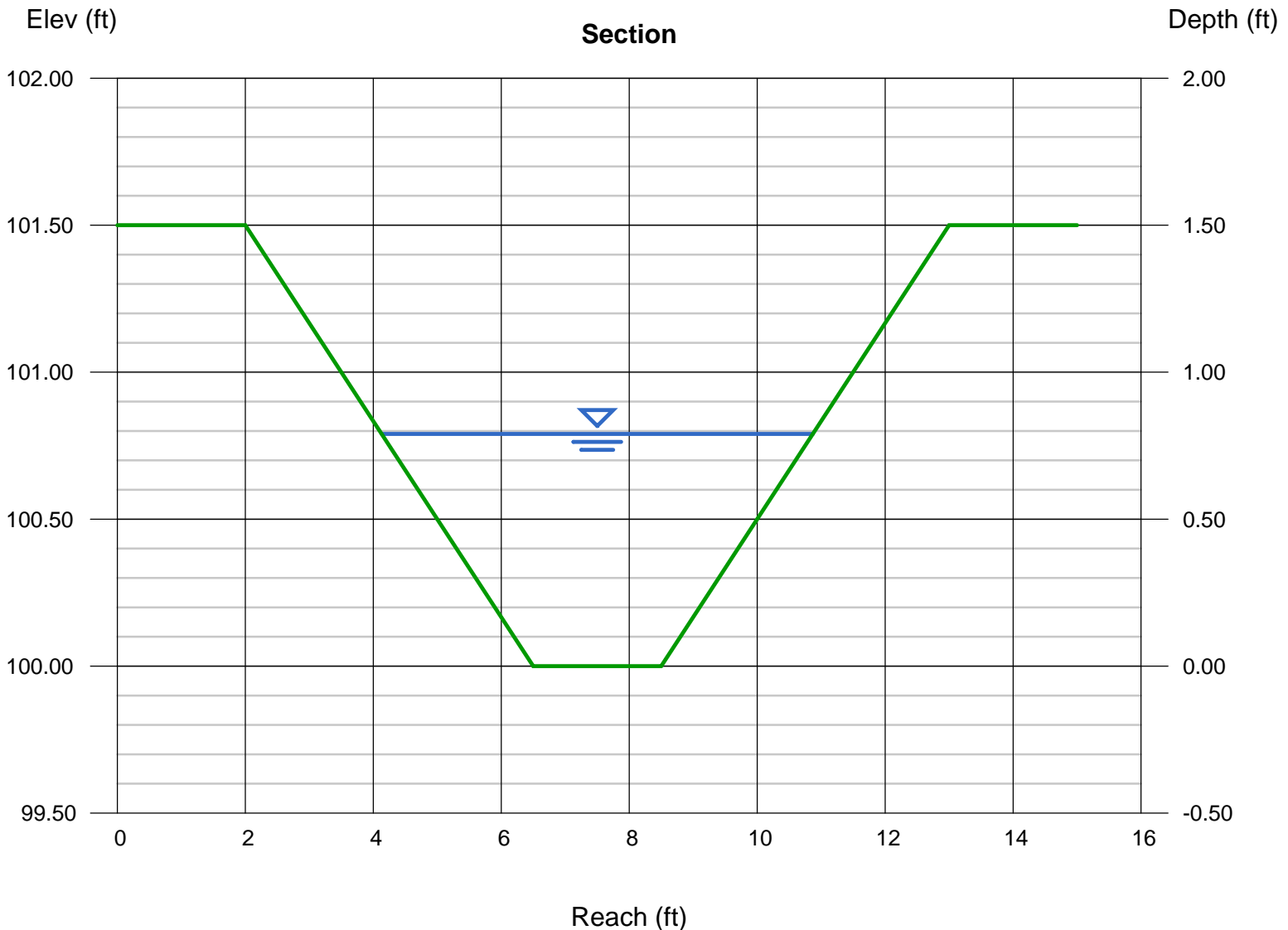

# Channel Report

## PERIMETER DRAINAGE DITCH - CELL 1 - PERIMETER DITCH 2B.1

### Trapezoidal

Bottom Width (ft) = 2.00  
Side Slopes (z:1) = 3.00, 3.00  
Total Depth (ft) = 2.00  
Invert Elev (ft) = 100.00  
Slope (%) = 1.50  
N-Value = 0.030

### Highlighted

Depth (ft) = 1.03  
Q (cfs) = 22.85  
Area (sqft) = 5.24  
Velocity (ft/s) = 4.36  
Wetted Perim (ft) = 8.51  
Crit Depth, Yc (ft) = 1.01  
Top Width (ft) = 8.18  
EGL (ft) = 1.33

### Calculations

Compute by: Known Q  
Known Q (cfs) = 22.85

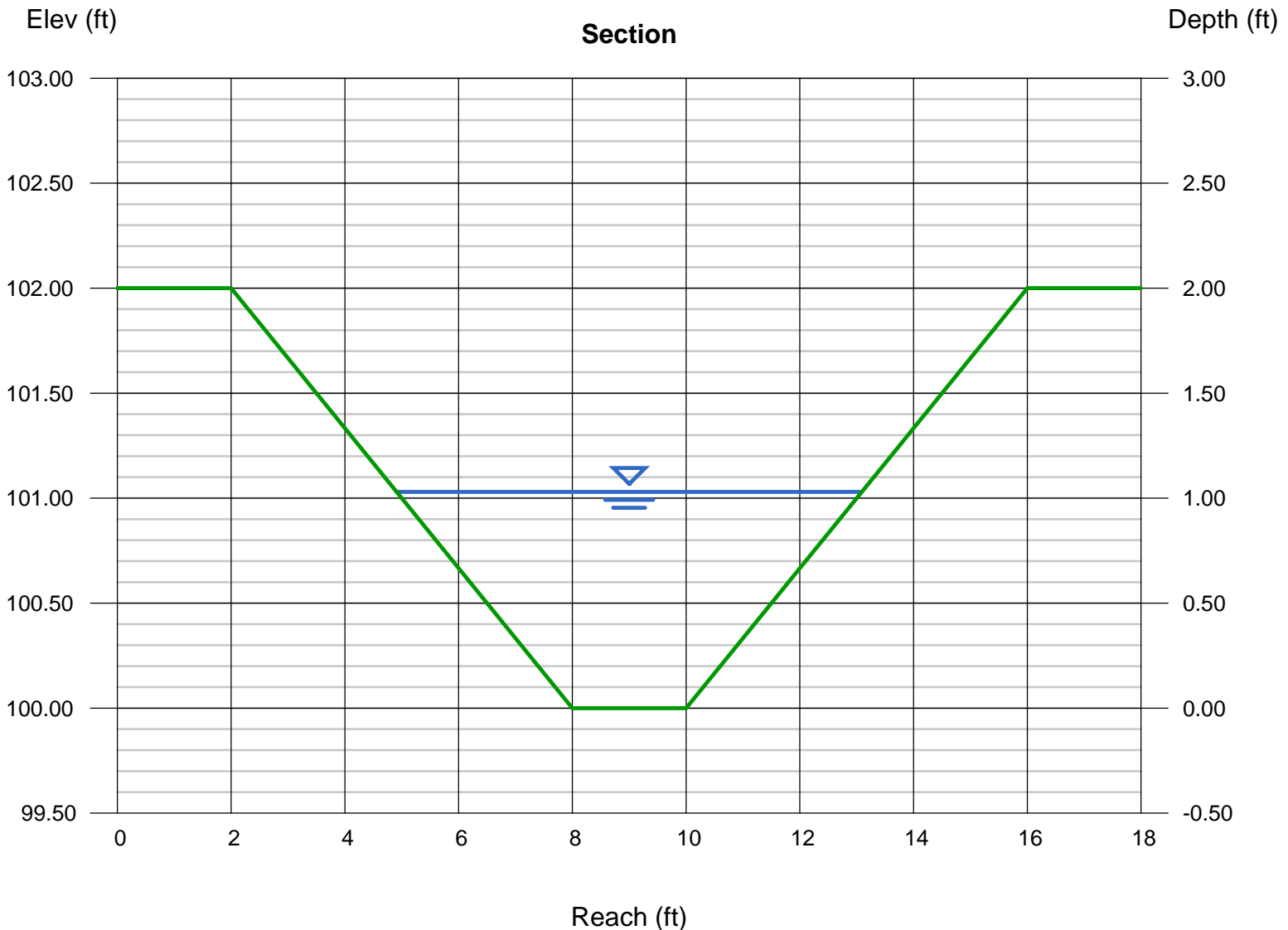

# Channel Report

## PERIMETER DRAINAGE DITCH - CELL 1 - PERIMETER DITCH 2B.2

### Trapezoidal

Bottom Width (ft) = 2.00  
Side Slopes (z:1) = 3.00, 3.00  
Total Depth (ft) = 1.50  
Invert Elev (ft) = 100.00  
Slope (%) = 1.00  
N-Value = 0.030

### Highlighted

Depth (ft) = 0.76  
Q (cfs) = 9.790  
Area (sqft) = 3.25  
Velocity (ft/s) = 3.01  
Wetted Perim (ft) = 6.81  
Crit Depth, Yc (ft) = 0.66  
Top Width (ft) = 6.56  
EGL (ft) = 0.90

### Calculations

Compute by: Known Q  
Known Q (cfs) = 9.79

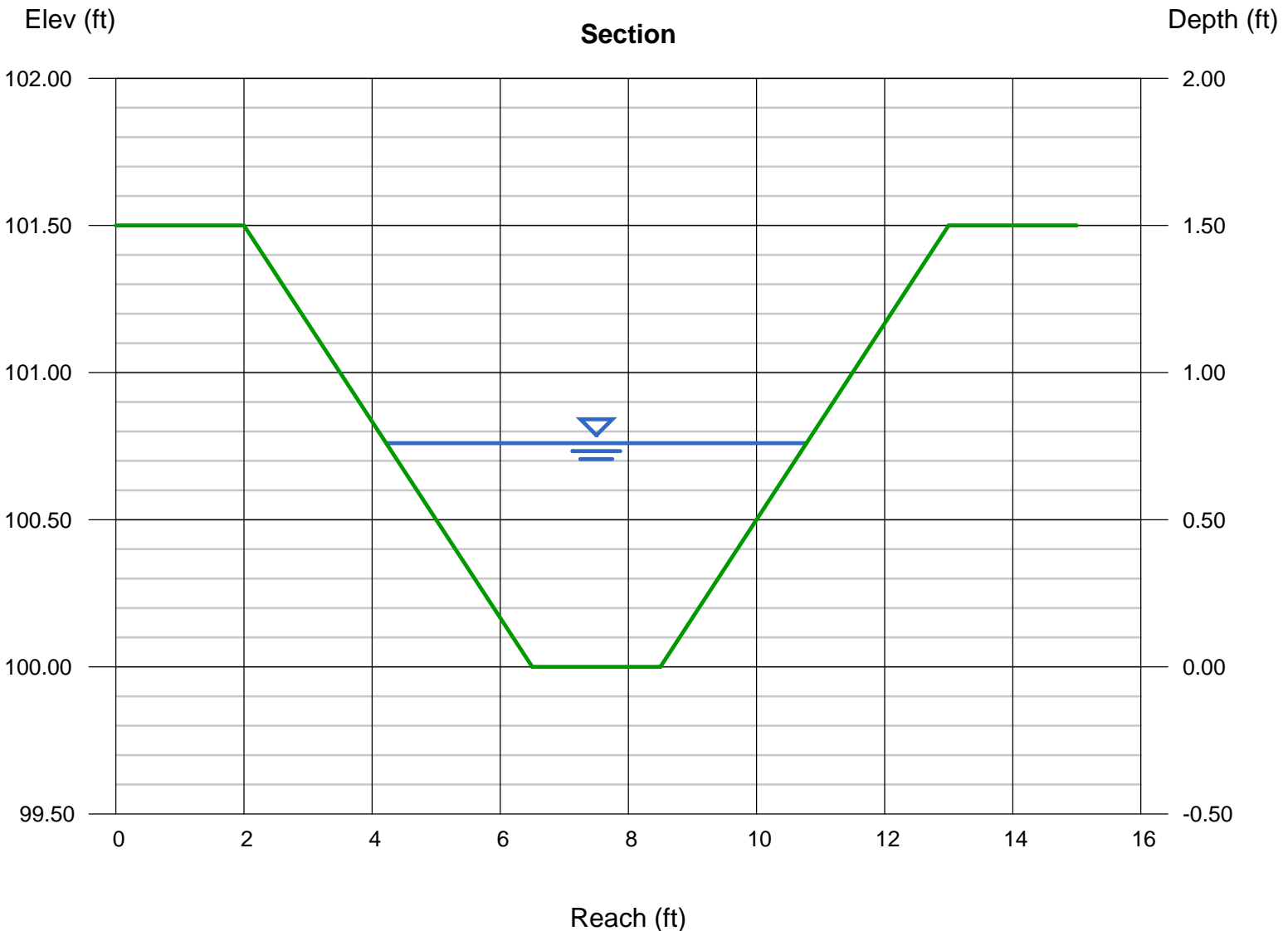

# Channel Report

## PERIMETER DRAINAGE DITCH - CELL 1 - PERIMETER DITCH 1C.1

### Trapezoidal

Bottom Width (ft) = 2.00  
Side Slopes (z:1) = 3.00, 3.00  
Total Depth (ft) = 2.00  
Invert Elev (ft) = 100.00  
Slope (%) = 1.80  
N-Value = 0.030

### Highlighted

Depth (ft) = 1.15  
Q (cfs) = 31.74  
Area (sqft) = 6.27  
Velocity (ft/s) = 5.06  
Wetted Perim (ft) = 9.27  
Crit Depth, Yc (ft) = 1.19  
Top Width (ft) = 8.90  
EGL (ft) = 1.55

### Calculations

Compute by: Known Q  
Known Q (cfs) = 31.74

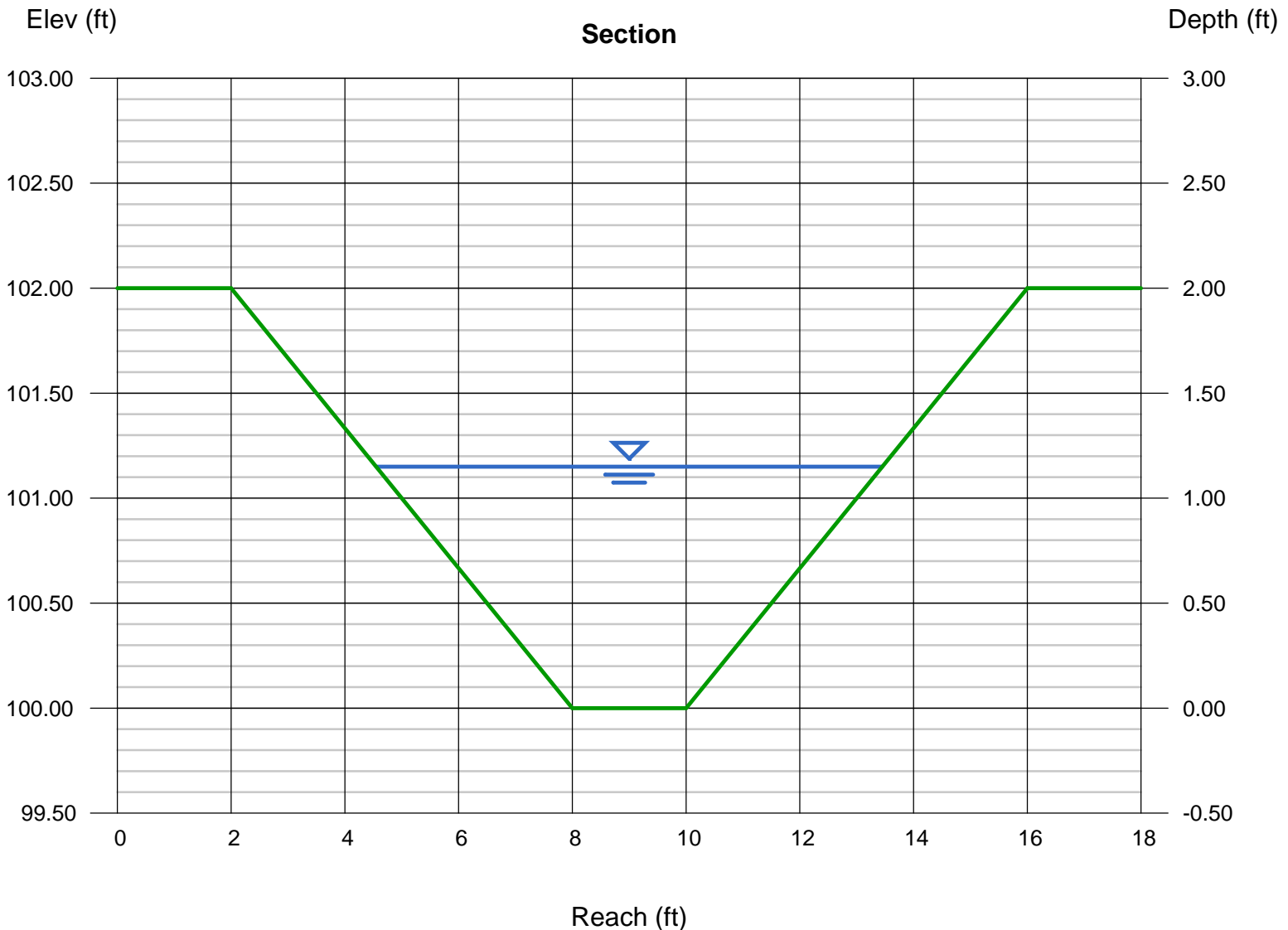

# Channel Report

## PERIMETER DRAINAGE DITCH - CELL 1 - PERIMETER DITCH 1C.2

### Trapezoidal

Bottom Width (ft)	= 4.00
Side Slopes (z:1)	= 3.00, 3.00
Total Depth (ft)	= 2.00
Invert Elev (ft)	= 100.00
Slope (%)	= 3.50
N-Value	= 0.030

### Highlighted

Depth (ft)	= 0.96
Q (cfs)	= 46.00
Area (sqft)	= 6.60
Velocity (ft/s)	= 6.96
Wetted Perim (ft)	= 10.07
Crit Depth, Yc (ft)	= 1.20
Top Width (ft)	= 9.76
EGL (ft)	= 1.71

### Calculations

Compute by:	Known Q
Known Q (cfs)	= 46.00

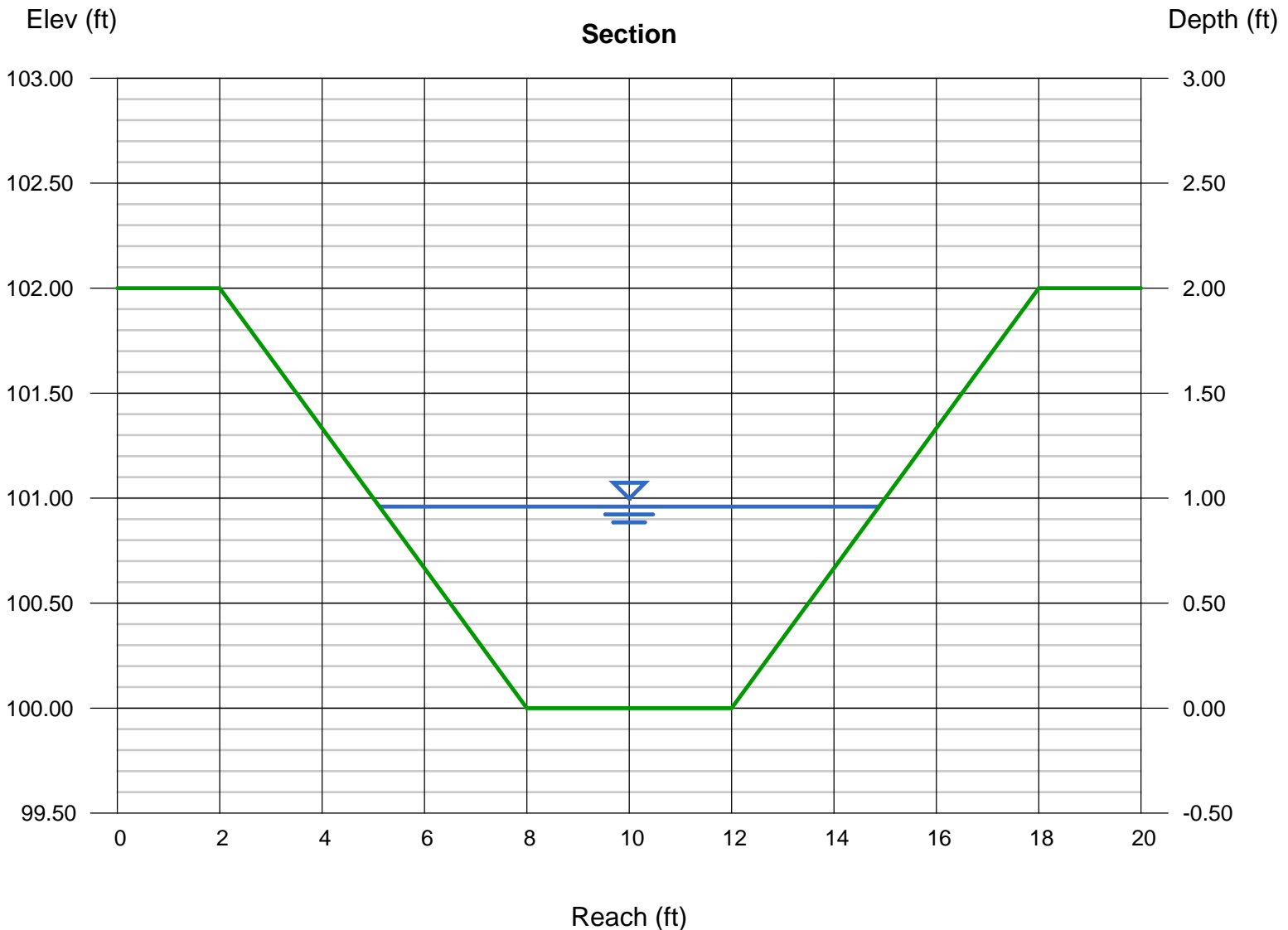

# Channel Report

## PERIMETER DRAINAGE DITCH - CELL 1 - PERIMETER DITCH 1C.3

### Trapezoidal

Bottom Width (ft) = 4.00  
Side Slopes (z:1) = 3.00, 3.00  
Total Depth (ft) = 2.00  
Invert Elev (ft) = 100.00  
Slope (%) = 3.50  
N-Value = 0.030

### Highlighted

Depth (ft) = 1.01  
Q (cfs) = 50.92  
Area (sqft) = 7.10  
Velocity (ft/s) = 7.17  
Wetted Perim (ft) = 10.39  
Crit Depth, Yc (ft) = 1.26  
Top Width (ft) = 10.06  
EGL (ft) = 1.81

### Calculations

Compute by: Known Q  
Known Q (cfs) = 50.92

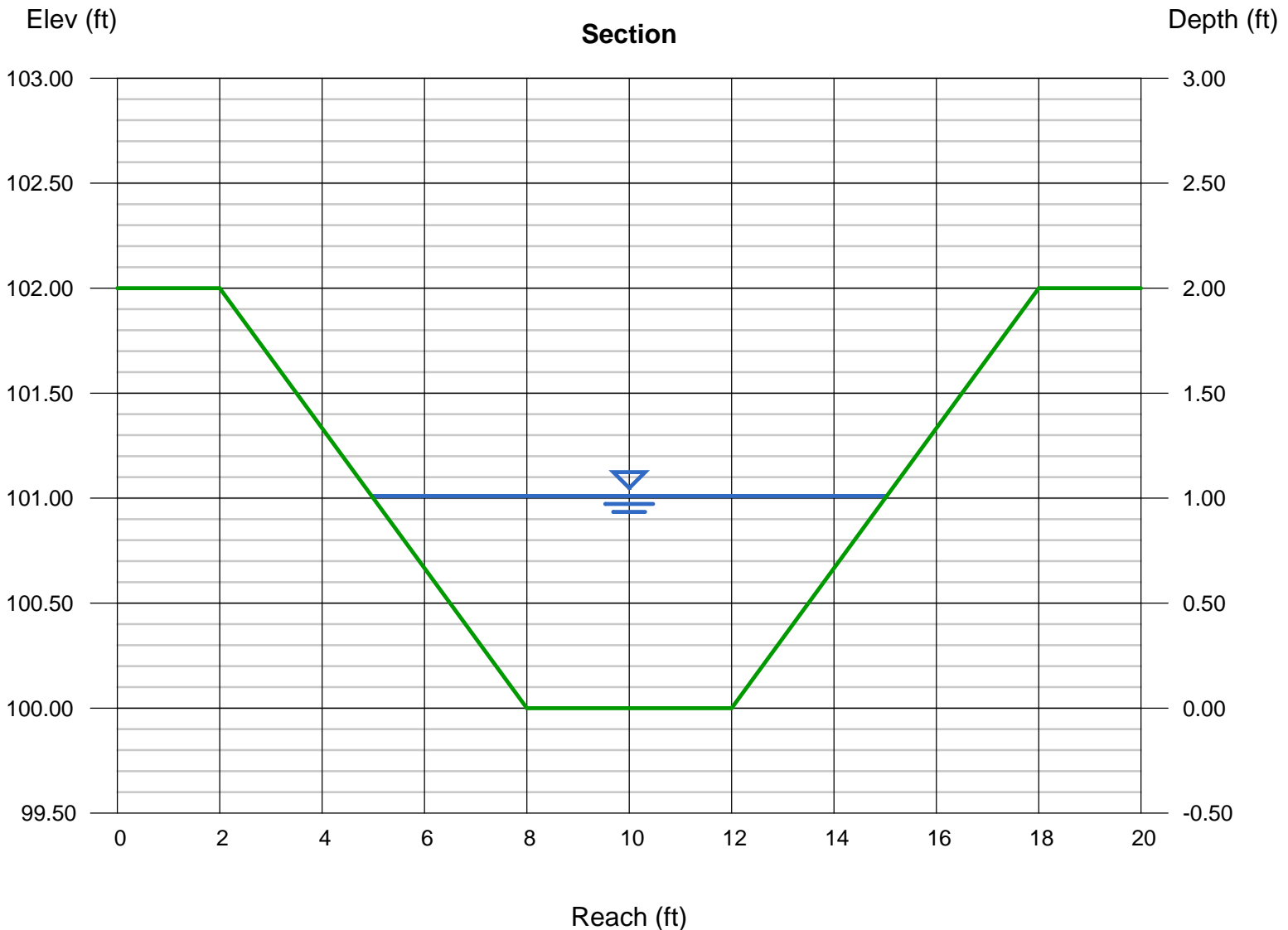

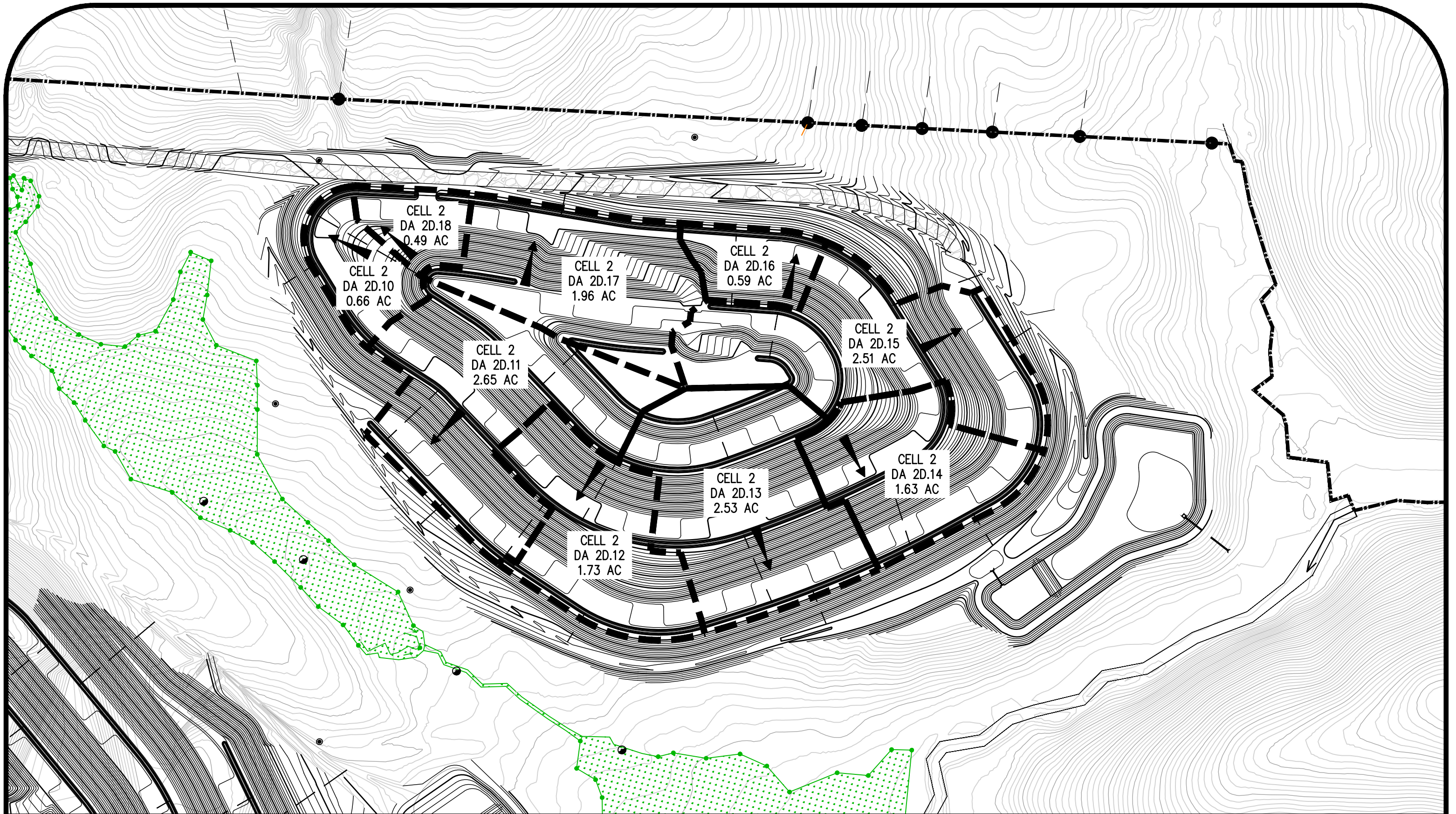

Documents prepared or furnished by Alliance Consulting Engineers, Inc. are instruments of service, and Alliance Consulting Engineers, Inc. retains an ownership and property interest (including the copyright and the right of reuse) in such documents, whether or not the project is completed.

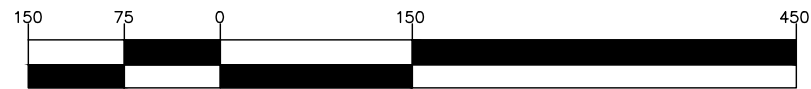

( IN FEET )

Project No.: 16227-0004  
March, 2018

## Slope Conveyance Drainage Map - Cell 2 for Project Greenpointe Landfill in Anderson County, South Carolina



Prepared by Alliance Consulting Engineers, Inc.  
124 Verdae Blvd, Greenville, SC 29607-3843  
864-284-1740  
www.alliancece.com



# Channel Report

## SLOPE CONVEYANCE DRAINAGE - CELL 2

### Trapezoidal

Bottom Width (ft) = 2.00  
Side Slopes (z:1) = 1.00, 1.00  
Total Depth (ft) = 2.00  
Invert Elev (ft) = 100.00  
Slope (%) = 1.00  
N-Value = 0.030

### Highlighted

Depth (ft) = 0.96  
Q (cfs) = 9.860  
Area (sqft) = 2.84  
Velocity (ft/s) = 3.47  
Wetted Perim (ft) = 4.72  
Crit Depth,  $Y_c$  (ft) = 0.80  
Top Width (ft) = 3.92  
EGL (ft) = 1.15

### Calculations

Compute by: Known Q  
Known Q (cfs) = 9.86

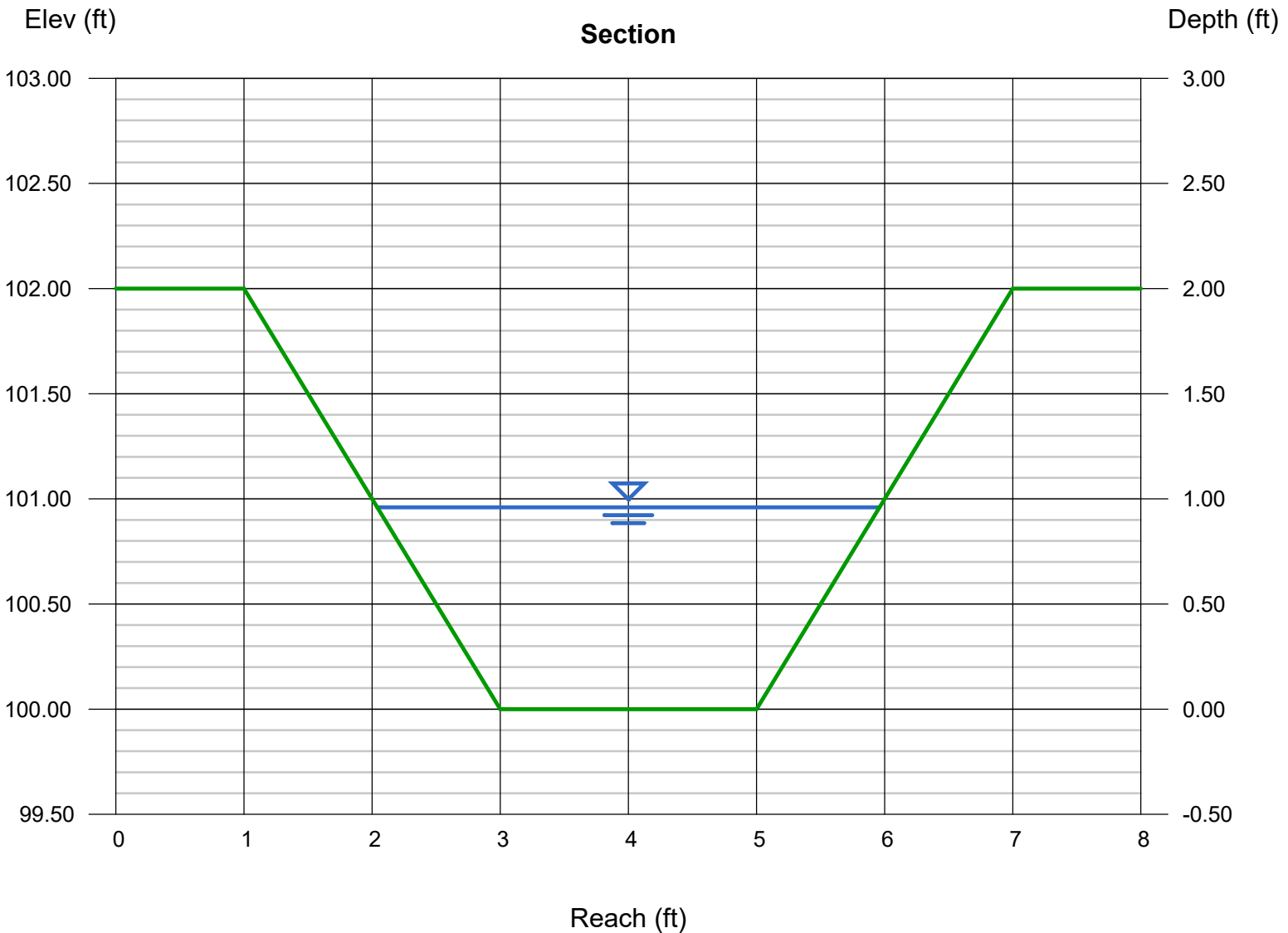

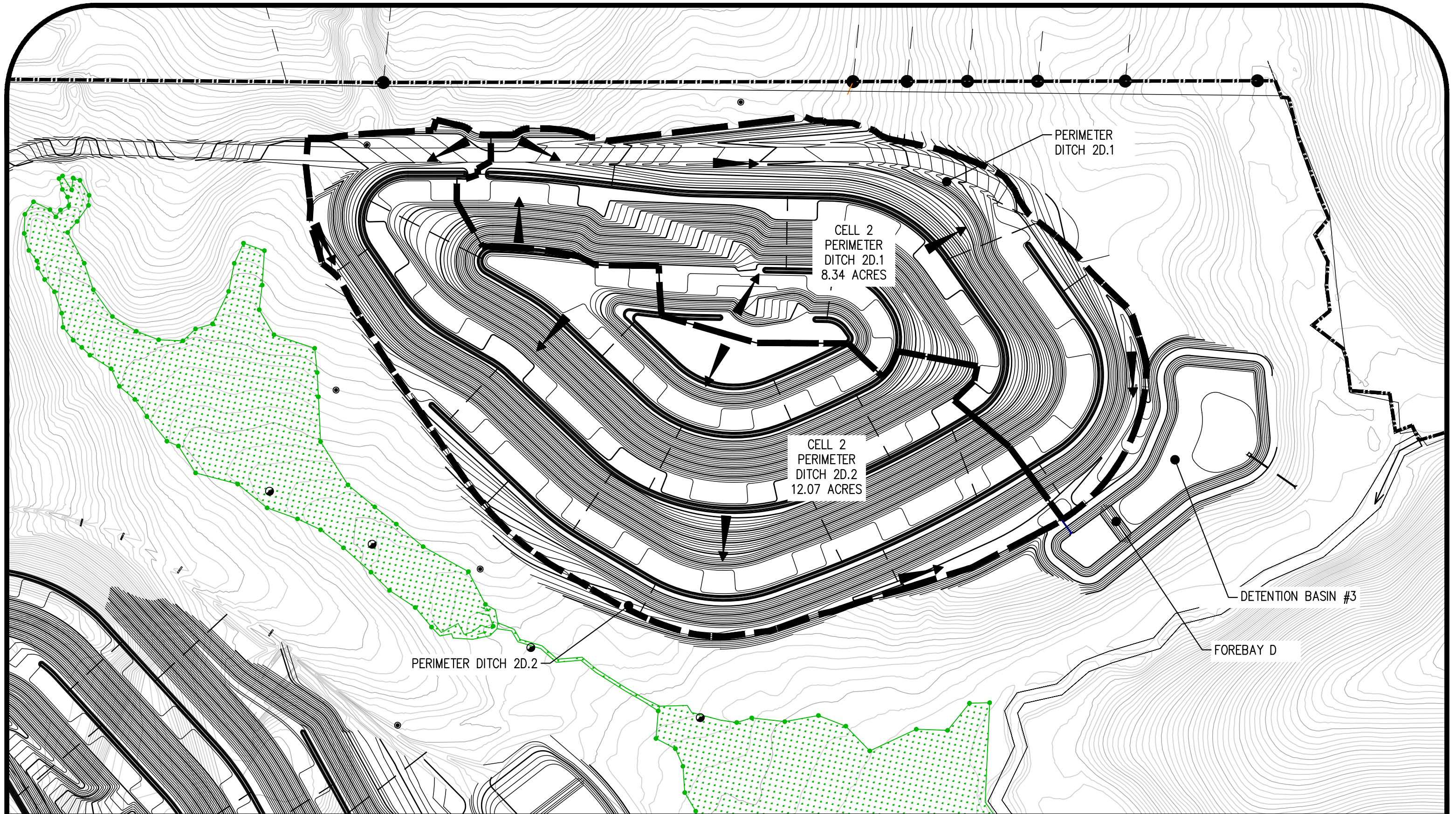

Documents prepared or furnished by Alliance Consulting Engineers, Inc. are instruments of service, and Alliance Consulting Engineers, Inc. retains an ownership and property interest (including the copyright and the right of reuse) in such documents, whether or not the project is completed.

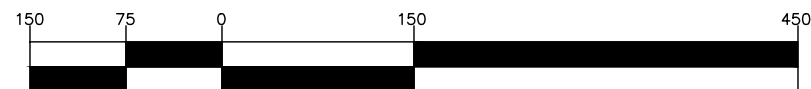

( IN FEET )

Project No.: 16227-0004  
March, 2018

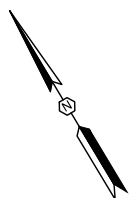

## Perimeter Ditch Drainage Map - Cell 2 for Project Greenpointe Landfill in Anderson County, South Carolina



Prepared by Alliance Consulting Engineers, Inc.  
124 Verdae Blvd, Greenville, SC 29607-3843  
864-284-1740  
www.alliancece.com

# Channel Report

## PERIMETER DRAINAGE DITCH - CELL 2 - PERIMETER DITCH 2D.1

### Trapezoidal

Bottom Width (ft) = 2.00  
Side Slopes (z:1) = 3.00, 3.00  
Total Depth (ft) = 1.50  
Invert Elev (ft) = 100.00  
Slope (%) = 1.00  
N-Value = 0.030

### Highlighted

Depth (ft) = 0.76  
Q (cfs) = 9.790  
Area (sqft) = 3.25  
Velocity (ft/s) = 3.01  
Wetted Perim (ft) = 6.81  
Crit Depth, Yc (ft) = 0.66  
Top Width (ft) = 6.56  
EGL (ft) = 0.90

### Calculations

Compute by: Known Q  
Known Q (cfs) = 9.79

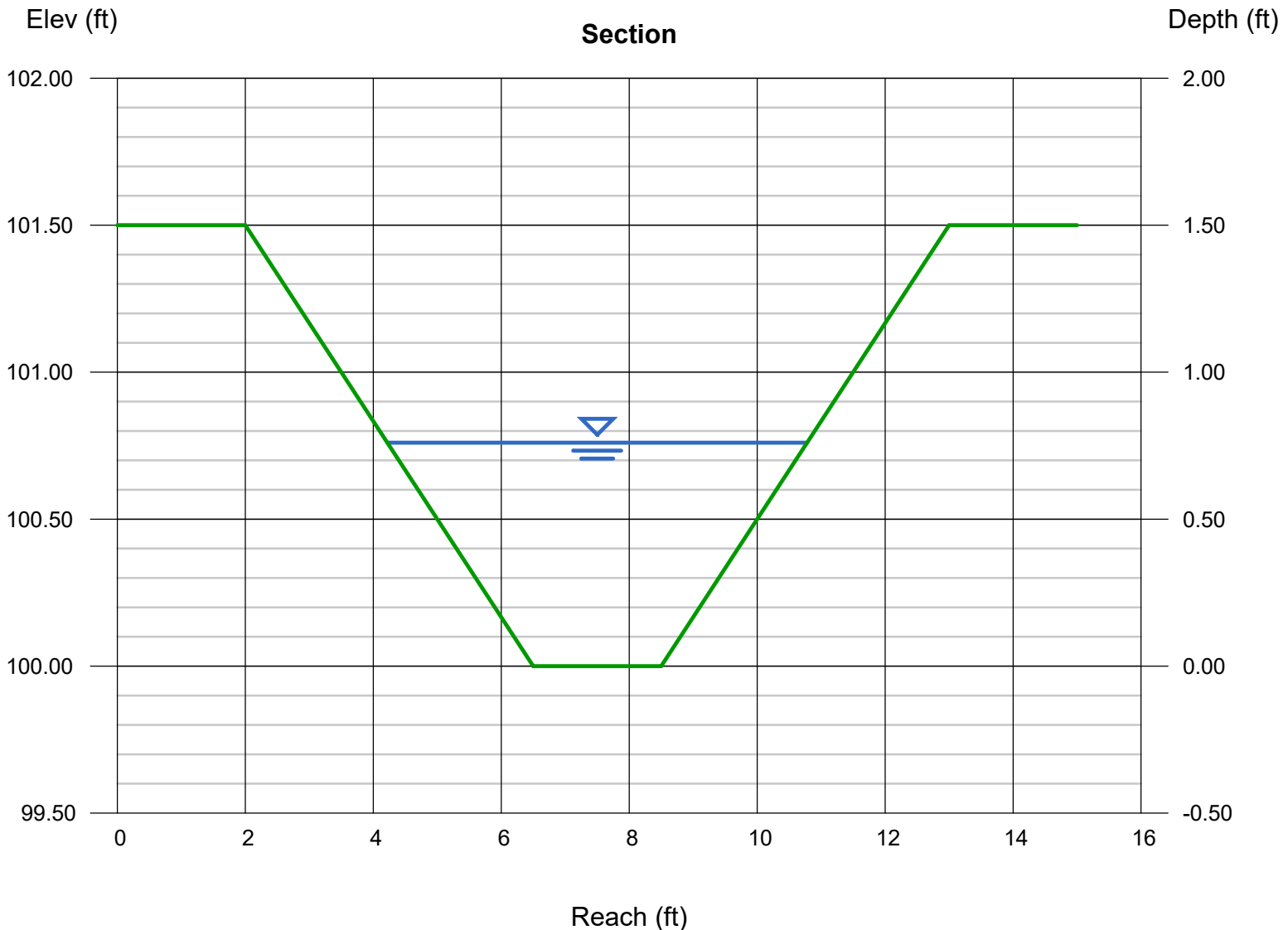

# Channel Report

## PERIMETER DRAINAGE DITCH - CELL 2 - PERIMETER DITCH 2D.2

### Trapezoidal

Bottom Width (ft) = 5.00  
Side Slopes (z:1) = 3.00, 3.00  
Total Depth (ft) = 1.50  
Invert Elev (ft) = 100.00  
Slope (%) = 1.00  
N-Value = 0.030

### Highlighted

Depth (ft) = 1.21  
Q (cfs) = 44.91  
Area (sqft) = 10.44  
Velocity (ft/s) = 4.30  
Wetted Perim (ft) = 12.65  
Crit Depth, Yc (ft) = 1.09  
Top Width (ft) = 12.26  
EGL (ft) = 1.50

### Calculations

Compute by: Known Q  
Known Q (cfs) = 44.91

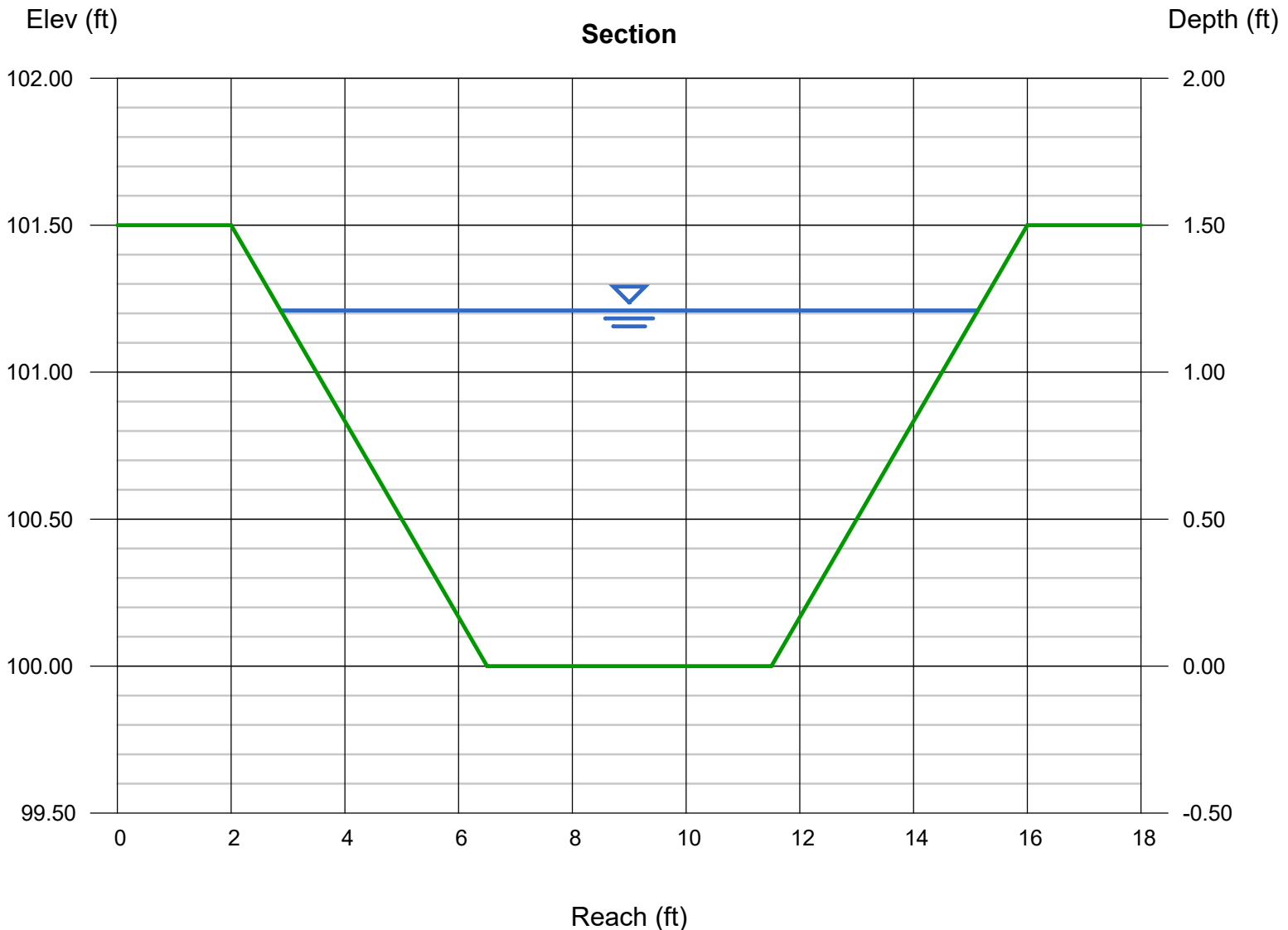

**APPENDIX F      Additional Calculations**

- **Basin Trapping Efficiency**
- **Rip Rap Calculations**

# Sediment Basin Trapping Efficiency

SCDHEC method (basin is NOT in low lying area & no high water table)

**Basin ID=** Detention Basin #1      **Efficiency =** 91.52 % (80% req'd)  
 Okay? Yes, OK

**Soil Type=** MADISON (B) name of soil  
**Soil Strata=** 0 - 6 0.0060 range in inches - D<sub>15</sub>

**Basin Ratio=**  $q_{po}/AV_{15}$   
**q<sub>po</sub>=** 1.0 cfs Peak outflow rate from basin - 10 yr 24 hr event  
**A=** 42926.0 ft<sup>2</sup> Surface area of pond at riser crest  
**D<sub>15</sub>=** 0.006 mm (from soil tables)  
**V<sub>15</sub>=** 1.01E-04 ft/sec (from eqns) (if D<sub>15</sub> < 0.01 mm then V<sub>15</sub>=2.81D<sub>15</sub><sup>2</sup>)  
**Ratio=** 9.73E+03 (if D<sub>15</sub> ≥ 0.01 mm then log V<sub>15</sub> = -0.34246(log D<sub>15</sub>)<sup>2</sup> + 0.98912(log D<sub>15</sub>) - 0.33801)

**Constraints:**      **Meets Constraints?**  
**Watershed Area=** 17.3 acres Yes, OK ≤ 30 acre watershed  
**Overland Slope=** 6.0 % Yes, OK slope ≤ 20 percent  
**Outlet Diameter=** 24 inches Yes, OK outlet diameter ≤ 6 feet  
 basin NOT in low lying area and not having a high water table has a ratio=2.20e5 at 80%  
 basin IN low lying are and not having a high water table has a ratio=4.70e3 at 80%

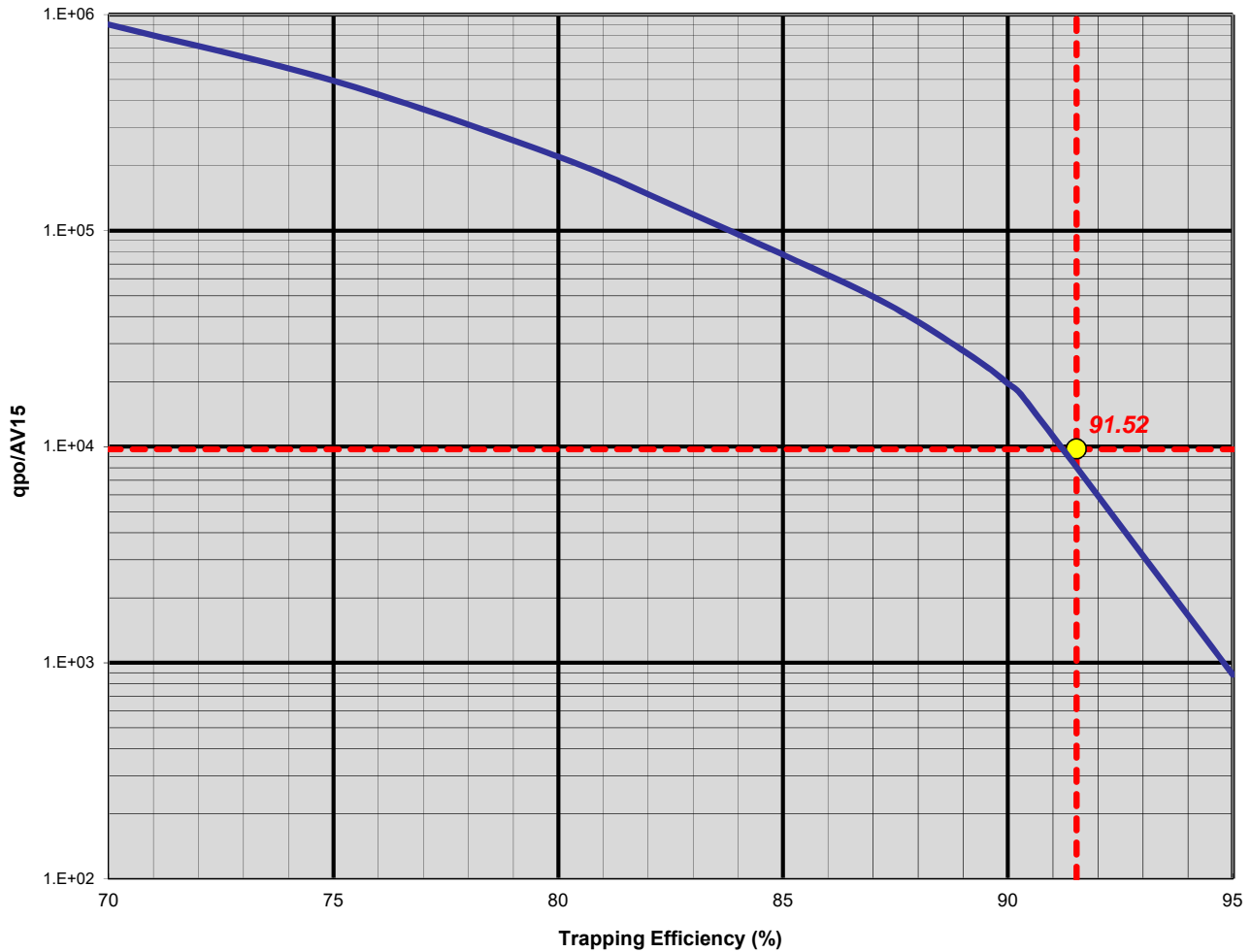

# Sediment Basin Trapping Efficiency

SCDHEC method (basin is NOT in low lying area & no high water table)

**Basin ID=** Detention Basin #2      **Efficiency =** 92.49 % (80% req'd)  
 Okay? Yes, OK

**Soil Type=** MADISON (B) name of soil  
**Soil Strata=** 0 - 6 0.0060 range in inches - D<sub>15</sub>

**Basin Ratio=**  $q_{po}/AV_{15}$   
 $q_{po}$  = 1.2 cfs      Peak outflow rate from basin - 10 yr 24 hr event  
**A=** 99469.0 ft<sup>2</sup>      Surface area of pond at riser crest  
**D<sub>15</sub>=** 0.006 mm      (from soil tables)  
**V<sub>15</sub>=** 1.01E-04 ft/sec      (from eqns)      (if D<sub>15</sub> < 0.01 mm then V<sub>15</sub> = 2.81D<sub>15</sub><sup>2</sup>)  
**Ratio=** 5.39E+03      (if D<sub>15</sub> >= 0.01 mm then log V<sub>15</sub> = -0.34246(log D<sub>15</sub>)<sup>2</sup> + 0.98912(log D<sub>15</sub>) - 0.33801)

**Constraints:**      **Meets Constraints?**  
**Watershed Area=** 27.6 acres      Yes, OK <= 30 acre watershed  
**Overland Slope=** 6.0 %      Yes, OK slope <= 20 percent  
**Outlet Diameter=** 42 inches      Yes, OK outlet diameter <= 6 feet  
 basin NOT in low lying area and not having a high water table has a ratio=2.20e5 at 80%  
 basin IN low lying are and not having a high water table has a ratio=4.70e3 at 80%

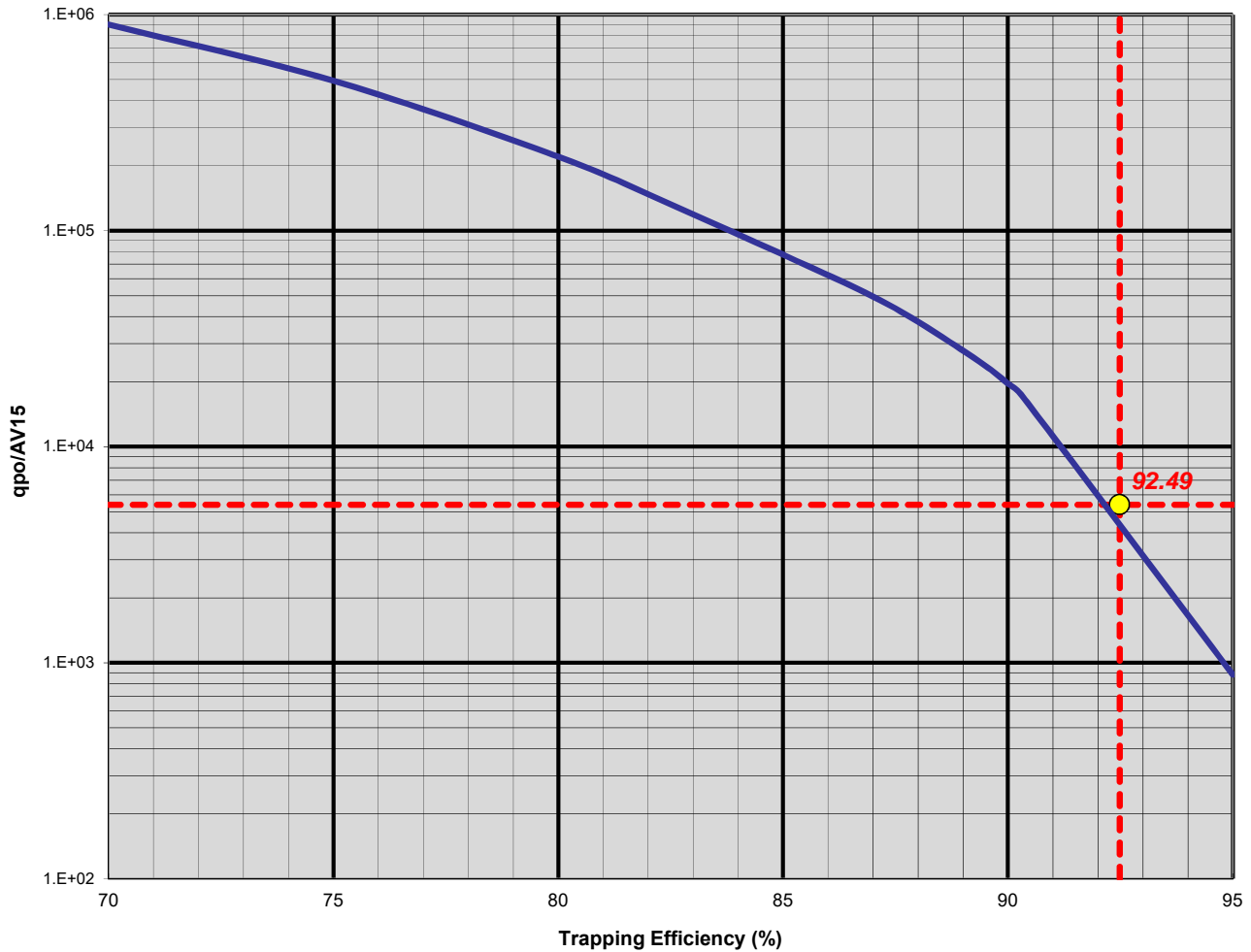

# Sediment Basin Trapping Efficiency

SCDHEC method (basin is NOT in low lying area & no high water table)

Basin ID= **Detention Basin #3**      Efficiency = **84.10 %** (80% req'd)  
 Okay? **Yes, OK**

Soil Type= **CECIL (B)** name of soil  
 Soil Strata= **0 - 7 0.0066** range in inches - D<sub>15</sub>

Basin Ratio= $q_{po}/AV_{15}$   
 $q_{po}$ = **15.24** cfs Peak outflow rate from basin - 10 yr 24 hr event  
 $A$ = **58076.0** ft<sup>2</sup> Surface area of pond at riser crest  
 $D_{15}$ = **0.0066** mm (from soil tables)  
 $V_{15}$ = **1.22E-04** ft/sec (from eqns) (if  $D_{15} < 0.01$  mm then  $V_{15} = 2.81D_{15}^2$ )  
 Ratio= **9.34E+04** (if  $D_{15} \geq 0.01$  mm then  $\log V_{15} = -0.34246(\log D_{15})^2 + 0.98912(\log D_{15}) - 0.33801$ )

**Constraints:**      **Meets Constraints?**  
 Watershed Area= **23.4** acres **Yes, OK** <= 30 acre watershed  
 Overland Slope= **6.0** % **Yes, OK** slope <= 20 percent  
 Outlet Diameter= **36** inches **Yes, OK** outlet diameter <= 6 feet  
 basin NOT in low lying area and not having a high water table has a ratio=2.20e5 at 80%  
 basin IN low lying are and not having a high water table has a ratio=4.70e3 at 80%

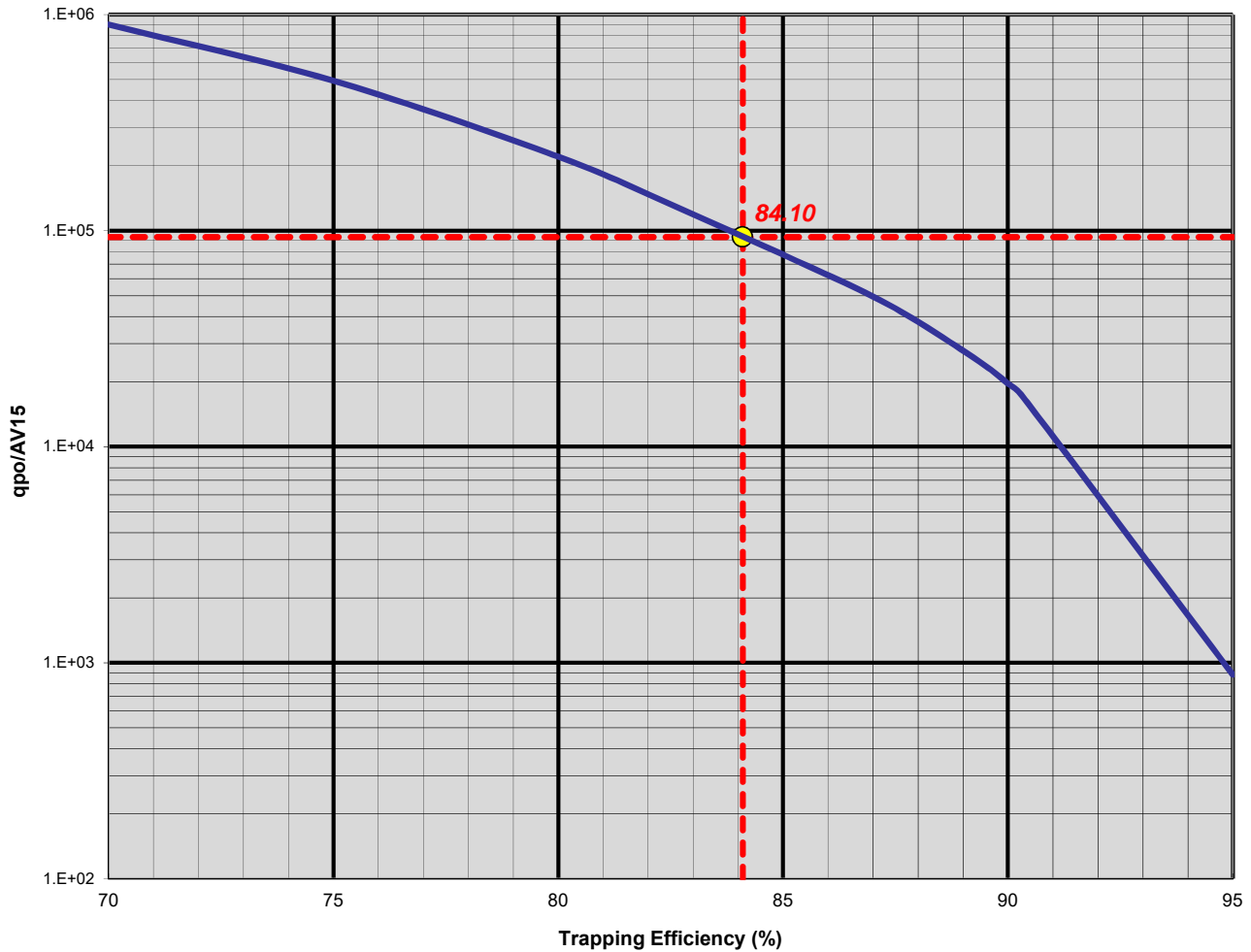



# RIP-RAP FOR OUTFALL PIPE OF DETENTION BASIN 1

**DESIGN OF OUTFLET PROTECTION FROM A ROUND PIPE FLOWING FULL  
MINIMUM TAILWATER CONDITION ( $T_w < 0.5$  DIAMETER)**

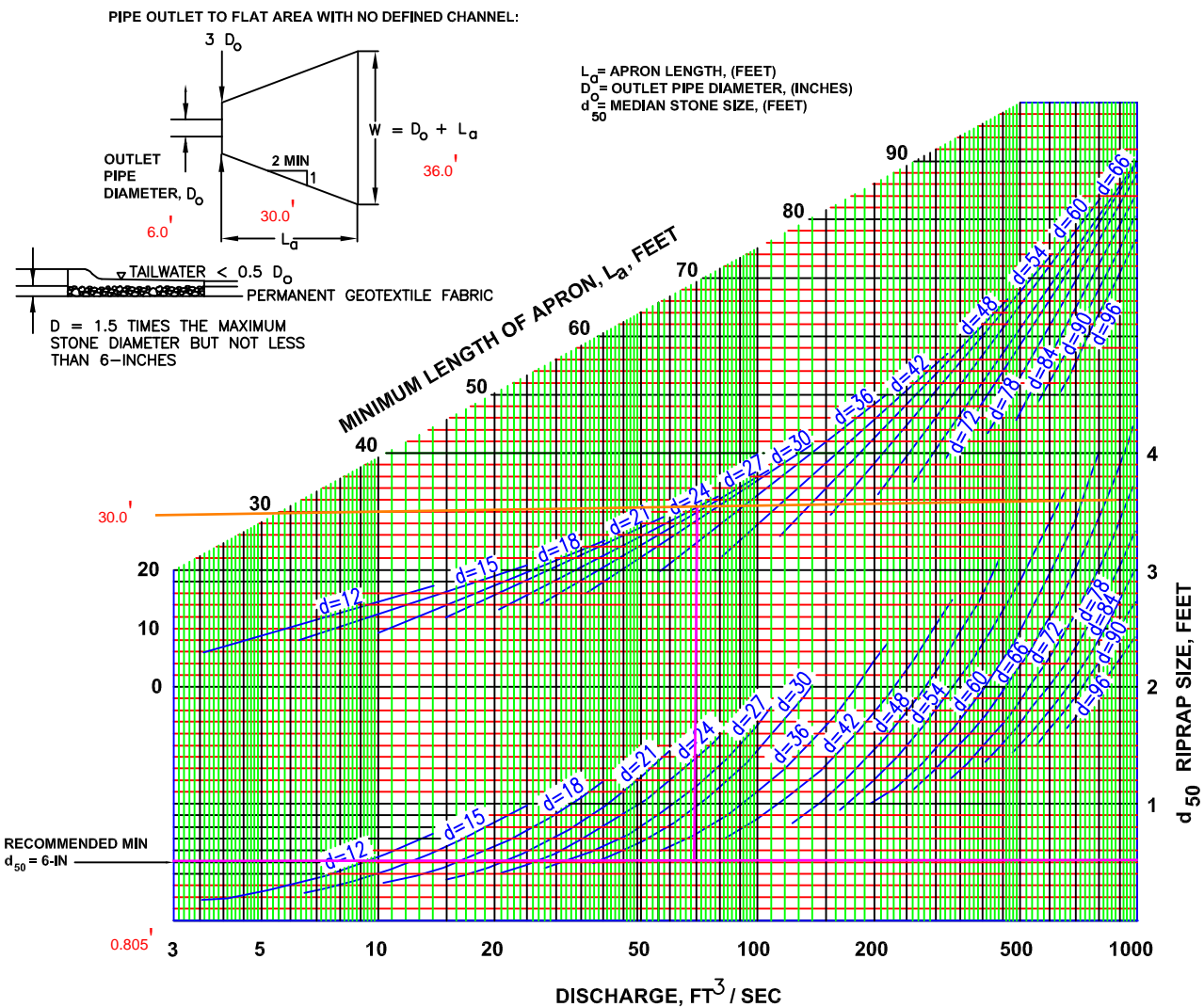

South Carolina  
 Department of Health  
 and Environmental Control

**FIGURE RR-6**  
**MINIMUM TAIL WATER CONDITION**  
 EFFECTIVE DATE: AUGUST, 2005

# RIP-RAP FOR OUTFALL PIPE OF DETENTION BASIN 2

**DESIGN OF OUTFLET PROTECTION FROM A ROUND PIPE FLOWING FULL**  
**MINIMUM TAILWATER CONDITION ( $T_w < 0.5$  DIAMETER)**

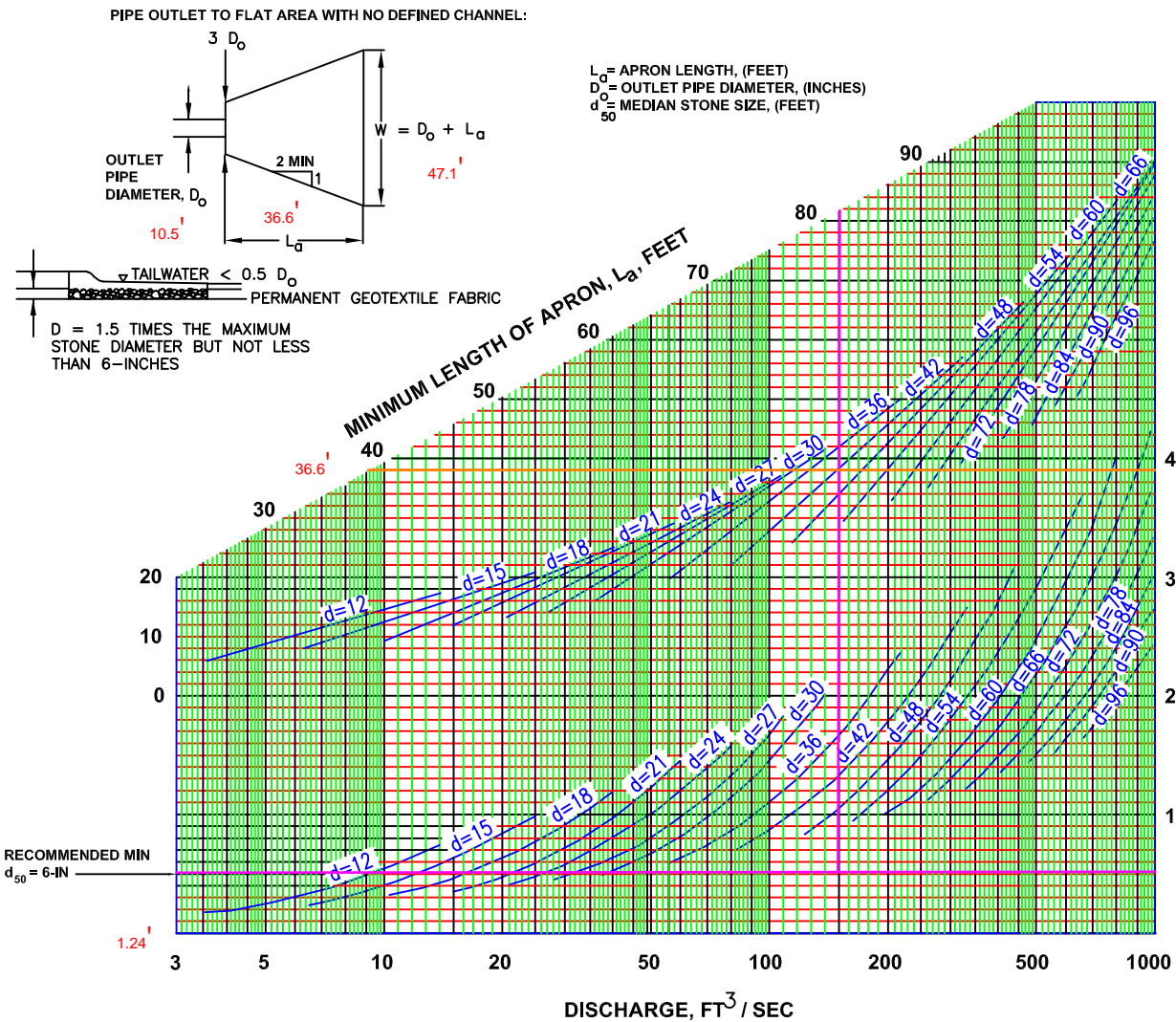

**FIGURE RR-6**  
**MINIMUM TAIL WATER CONDITION**  
 South Carolina  
 Department of Health  
 and Environmental Control  
 EFFECTIVE DATE: AUGUST, 2005

# RIP-RAP FOR OUTFALL PIPE OF DETENTION BASIN 3

**DESIGN OF OUTFLET PROTECTION FROM A ROUND PIPE FLOWING FULL**  
**MINIMUM TAILWATER CONDITION ( $T_w < 0.5$  DIAMETER)**

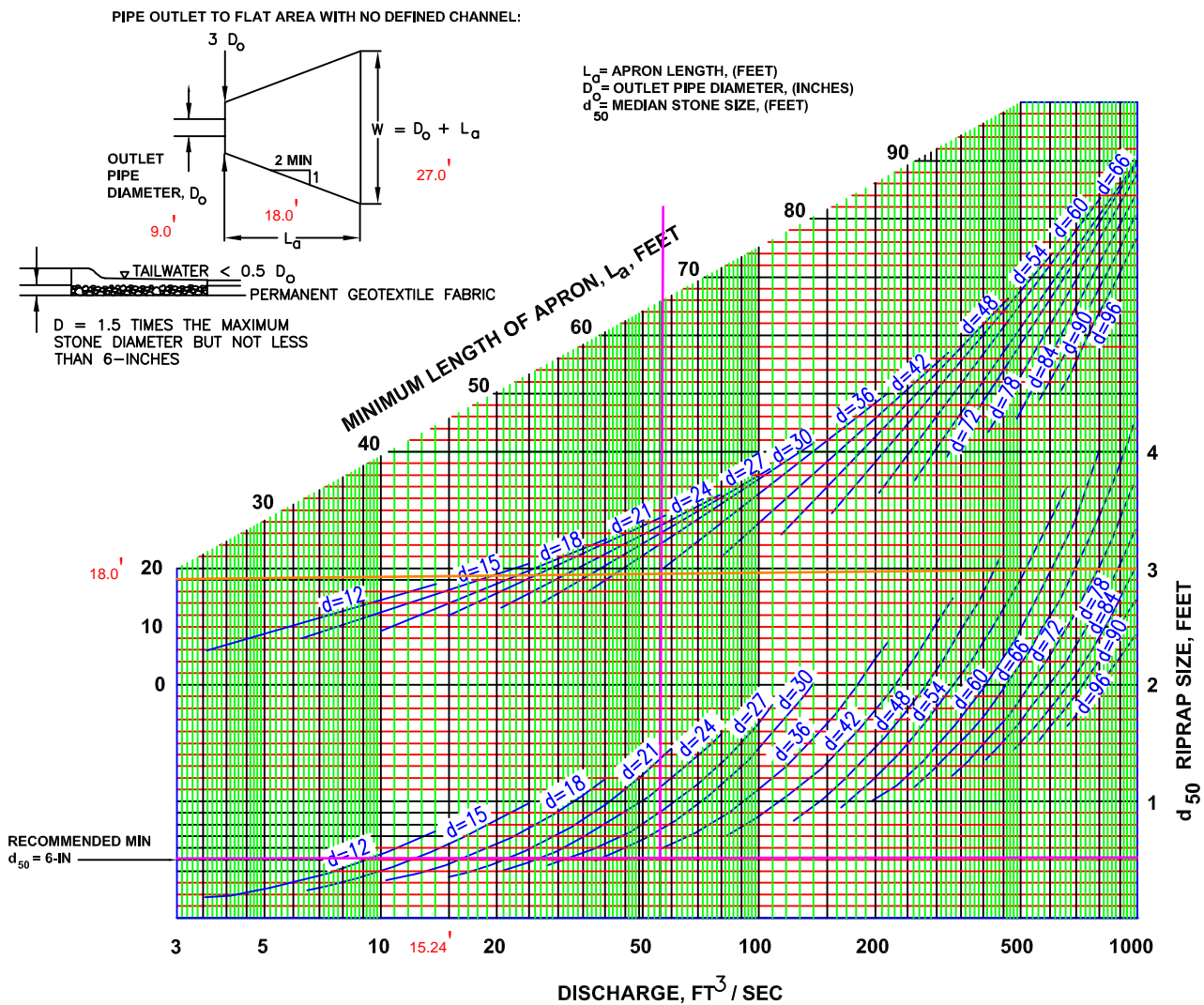

South Carolina  
 Department of Health  
 and Environmental Control

**FIGURE RR-6**  
**MINIMUM TAIL WATER CONDITION**  
 EFFECTIVE DATE: AUGUST, 2005

RIP-RAP FOR OUTFALL PIPE OF 36" RCP PIPE IN CELL 1

DESIGN OF OUTFLET PROTECTION FROM A ROUND PIPE FLOWING FULL  
 MINIMUM TAILWATER CONDITION ( $T_w < 0.5$  DIAMETER)

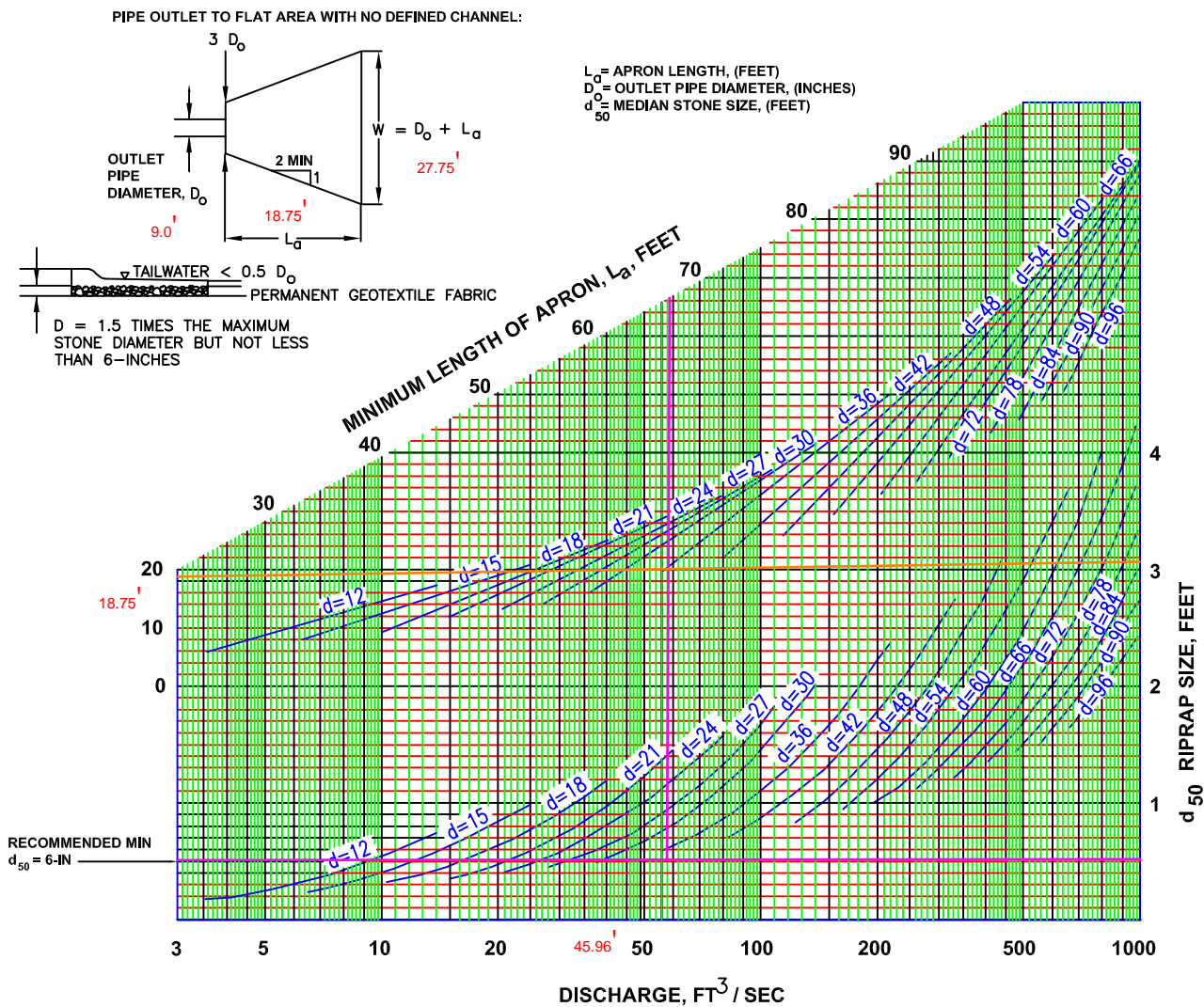

South Carolina  
 Department of Health  
 and Environmental Control

**FIGURE RR-6**  
**MINIMUM TAIL WATER CONDITION**  
 EFFECTIVE DATE: AUGUST, 2005

# RIP-RAP FOR OUTFALL 24" PIPE IN CELL 2

**DESIGN OF OUTFLET PROTECTION FROM A ROUND PIPE FLOWING FULL**  
**MINIMUM TAILWATER CONDITION ( $T_w < 0.5$  DIAMETER)**

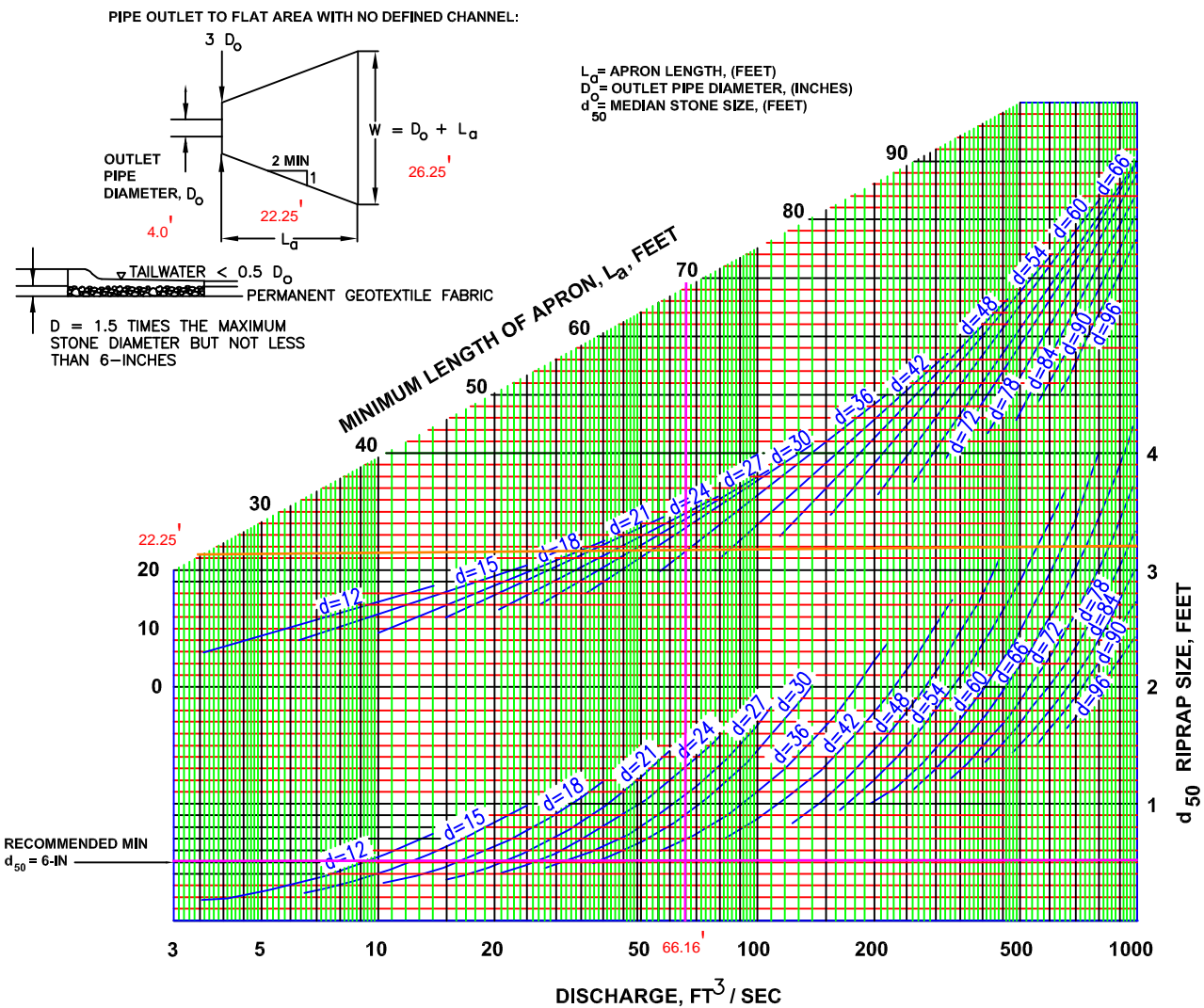

South Carolina  
 Department of Health  
 and Environmental Control

**FIGURE RR-6**  
**MINIMUM TAIL WATER CONDITION**  
 EFFECTIVE DATE: AUGUST, 2005

*Anderson County Fire Protection Commission*

210 McGee Road - Anderson, South Carolina 29625

Telephone: (864) 260-4016 / Fax: (864) 260-4015

GLENN G. HOLIDAY  
CHAIRMAN

PRESTON COX  
VICE CHAIRMAN

S.A.V.K. SORENSEN  
TREASURER

GERALD HANKS  
WILLIE WILES  
COMMISSION MEMBERS

*Jimmy Sutherland, County Fire Chief*  
*Brian Moon, Assistant County Fire Chief*



April 16, 2018

Mr. Radford Jenkins, Vice President  
Wasteco, Inc.  
Post Office Box 8028  
Greenville, South Carolina 29604

RE Anderson County Greenpointe Landfill  
Proposed Class Two C&D Expansion

Dear Mr. Jenkins:

The Greenpointe Class Two C&D Landfill, located at 500 Hamlin Road, is in the coverage area of the Anderson County Fire Department Station 19, Three and Twenty Fire Department.

If you have any questions, I may be contacted at the business number (864) 260-4016.

Thank you for your time.

Sincerely,

*Tommy Keaton* (arb)

Tommy Keaton, Fire Chief  
Three & Twenty Fire Dept

**Appendix I**  
**ACCEPTABLE WASTE FOR CLASS TWO LANDFILLS**

The following types of waste have been determined by the Department to be environmentally safe and may be accepted at Class Two Landfills unless specifically prohibited by the Department. Acceptable wastes may be generated by construction, demolition, land-clearing, industrial, and/or manufacturing activities, and/or obtained from segregated commercial waste. However, any of the materials listed in this appendix that have been contaminated by any hazardous constituent listed in the S.C. Hazardous Waste Management Regulations 61-79.261, or petroleum products, are prohibited from disposal at a Class Two Landfill.

Acceptable Land-Clearing Debris Such As:

- |   |  |
|---|--|
| <ul style="list-style-type: none"> <li>. brush &amp; limbs</li> <li>. earthen material, e.g., clays, sands, gravels, &amp; silts</li> <li>. logs</li> <li>. rock</li> </ul> | <ul style="list-style-type: none"> <li>. root mats</li> <li>. top soil</li> <li>. tree stumps</li> <li>. vegetation</li> </ul> |
|---|--|

Acceptable Debris Such As:

- |  |   |
|--|---|
| <ul style="list-style-type: none"> <li>. asbestos-containing material<sup>2</sup></li> <li>. bricks &amp; masonry blocks</li> <li>. cardboard</li> <li>. dry paint cans</li> <li>. dry caulking tubes</li> <li>. fiberglass matting</li> <li>. floor covering</li> <li>. glass</li> <li>. glass wire (optical fiber)</li> <li>. hardened asphaltic concrete<sup>3</sup></li> <li>. hardened cement</li> <li>. hardened concrete (may include rebar)</li> <li>. insulation material</li> <li>. lumber (includes treated lumber)</li> <li>. mirrors</li> </ul> | <ul style="list-style-type: none"> <li>. other items physically attached to structure, e.g., signs, mailboxes, awning, vinyl siding</li> <li>. other structural fabrics</li> <li>. packaging material</li> <li>. painted waste (includes lead-based paint)</li> <li>. pallets &amp; crates</li> <li>. pipes</li> <li>. plaster &amp; plasterboard</li> <li>. polyfiberglass (highly polished, cured material used for shower stalls, roofing, etc.)</li> <li>. shingles &amp; roofing materials</li> <li>. structural steel</li> <li>. tile (floor, wall &amp; ceiling)</li> <li>. tires<sup>4</sup></li> <li>. tubing</li> <li>. wall coverings</li> </ul> |
|--|---|

<sup>2</sup> Friable and nonfriable asbestos-containing material shall be disposed in a designated area and covered immediately upon receipt with at least six inches (6") of acceptable material. Prior to disposal of asbestos-containing material, the generator of the asbestos waste shall obtain a "permission for disposal" letter from the Department's Bureau of Air Quality (BAQ) and submit this letter to the landfill. All landfills accepting asbestos-containing material for disposal are subject to the BAQ regulation 61-86.1 Standards of Performance for Asbestos Abatement Operations, and the National Emissions Standards for Hazardous Air Pollutants[40CFR61, Subpart M;]

<sup>3</sup> Tar sealant material is not acceptable.

<sup>4</sup> Tires shall be reduced in size by a minimum of one-eighth the size of the original tire prior to landfill disposal.

Acceptable Brown Goods:

- . box springs
- . mattresses
- . wooden swing sets
- . nonmotorized bulky outdoor children's toys
- . furniture including lawn furniture:
  - laminated
  - metal<sup>5</sup>
  - plastic
  - PVC
  - vinyl
  - wooden

Animal Carcasses Acceptable Under Following Conditions:

- . Animal carcasses shall be buried in a separate designated area. The facility shall submit to the Department a written request to dispose of animal carcasses including a plan that shows the portion of the landfill to be used for this type of disposal. The permit will be modified to reflect the designated disposal area, and;
- . Animal carcasses shall be buried and covered with at least twelve inches (12") of dirt immediately upon receipt.
- . Hydrated lime shall be added to the carcass and surrounding area before cover is applied to control bacterial growth and odor.
- . Mass kill burial shall not be acceptable at Class Two Landfills unless approved by the Department prior to disposal.

---

<sup>5</sup>The Department recommends that all metal furniture be recycled if feasible.



---

**Appendix II**  
**UNACCEPTABLE WASTE FOR CLASS TWO LANDFILLS**

The following types of waste have been determined to pose a potential threat to the environment and shall not be accepted at Class Two Landfills. Wastes are considered to be contaminated if a waste has come into contact with and maintains a residue or characteristic of the contaminated materials as described herein.

Any Waste That Has Been Contaminated by Petroleum Products Such As:

- |                            |                        |
|----------------------------|------------------------|
| . absorbent (vermiculite)  | . paper towels & rags  |
| . concrete                 | . pipes                |
| . containers               | . soil                 |
| . filters (oil, etc.)      | . storage tanks        |
| . mechanical/machine parts | . tar sealant material |

Any Waste That Has Been Contaminated by Polychlorinated Biphenyls (PCBs) Such As:

- |  |                         |
|--|-------------------------|
| . any waste that has come in contact with any liquid-containing PCBs | . electrical components |
| . capacitors   | . lighting ballasts     |
|  | . transformers          |

Any Waste That Has Been Contaminated by Organic Chemicals or Solvents (industrial plants, chemical plants, laboratories, construction sites, etc.) Such As:

- |                                 |   |
|---------------------------------|---|
| . absorbent                     | . mechanical/machine parts (valves, etc.) |
| . adhesives                     | . paint thinner                           |
| . caulking compounds            | . pipes                                   |
| . cement                        | . pumps                                   |
| . containers (packaging)        | . soil                                    |
| . filters                       | . storage tanks                           |
| . flooring (wood, carpet, etc.) | . tar                                     |
| . glazing compound              | . vats                                    |

Any Waste That Has Been Contaminated by Preservatives, (pentachlorophenol & creosote) Such As:

- |  |                 |
|--|-----------------|
| . containers                                       | . railroad ties |
| . mechanical parts used in manufacturing processes | . soil          |
|  | . utility poles |

Any Waste That Has Been Contaminated by Pesticides/Herbicides Such As:

- |                                  |                       |
|----------------------------------|-----------------------|
| . concrete                       | . pallets & crates    |
| . containers (packaging)         | . soil                |
| . equipment used for application | . vats                |
| . mechanical/machine parts       | . wood (storage area) |

Miscellaneous Waste Such As:

- . lamps<sup>6</sup>
- . liquid waste (paint, paint thinner, etc.)
- . unpolished fiberglass (Bondo)
- . wastes/substances determined by the Department to be unacceptable

Cathode Ray Tubes (CRTs) and Electronic Equipment Such As:

- . cameras
- . compact discs (CDs)
- . computers
- . computer monitors
- . communication & navigation equipment
- . Digital Versatile Disc (DVDs)
- . displays
- . hand-held video game machines
- . mainframes
- . microwave ovens
- . personal digital assistants (PDAs)
- . radios
- . stereos
- . televisions
- . test equipment (oscilloscopes, etc.)
- . video cassette recorders (VCRs)
- . video game machines

---

<sup>6</sup>Fluorescent lamps and high intensity discharge (HID) lamps such as metal halide and mercury vapor lamps.

---

**Appendix III**  
**CONSTITUENTS FOR DETECTION MONITORING FOR CLASS TWO LANDFILLS**

<u>Common name</u>	<u>CAS RN</u>
pH	
Specific Conductance	
Temperature	
<u>Inorganic Constituents:</u>	
(1) Arsenic	(Total)
(2) Barium	(Total)
(3) Cadmium	(Total)
(4) Chromium	(Total)
(5) Lead	(Total)
(6) Mercury	(Total)
(7) Selenium	(Total)
(8) Silver	(Total)
(9) Chloride	(Total)
(10) Nitrate	(Total)
(11) Sulfate	(Total)
<u>Organic Constituents:</u>	
(12) Benzene	71-43-2
(13) Carbon tetrachloride	56-23-5
(14) Chlorobenzene	108-90-7
(15) Chloroform; Trichloromethane	67-66-3
(16) 1,1-Dichloroethane; Ethylidene chloride	75-34-3
(17) 1,2-Dichloroethane; Ethylene dichloride	107-06-2
(18) 1,1-Dichloroethylene; 1,1-Dichloroethene; Vinylidene chloride	75-35-4
(19) cis-1,2-Dichloroethylene; cis-1,2-Dichloroethene	156-59-2
(20) trans-1,2-Dichloroethylene; trans-1,2-Dichloroethene	156-60-5
(21) Ethylbenzene	100-41-4
(22) Methylene chloride	75-09-2
(23) Tetrachloroethylene; Tetrachloroethene; Perchloroethylene	127-18-4
(24) Toluene	108-88-3
(25) 1,1,1-Trichloroethane; Methylchloroform	71-55-6
(26) 1,1,2-Trichloroethane	79-00-5
(27) Trichloroethylene; Trichloroethene	79-01-6
(28) Vinyl chloride	75-01-4
(29) Xylenes	1330-20-7



August 24, 2015

Mr. David Oberly II, Hydrogeologist  
Solid Waste Groundwater Section  
Division of Mining and Solid Waste Management  
SCDHEC - BLWM  
2600 Bull Street, Columbia, SC 29201

**RE: Groundwater Detection Monitoring Plan**  
Greenpointe C&D Landfill (#LF2-00001)  
500 Hamlin Road, Easley, Anderson County, SC

Dear Mr. Oberly:

Enclosed please find the Groundwater Detection Monitoring Plan for the Greenpointe C&D Landfill (Solid Waste Permit #LF2-00001) located at 500 Hamlin Road in Easley, Anderson County, South Carolina.

If you have any questions or require additional information, please feel free to contact HRP at (864) 289-0311.

Sincerely,

Salley Gould, GIT #26  
Project Geologist

Shaun C. Malin, P.G. #2454  
Project Manager

cc: Mr. Radford Jenkins, President, Greenpointe Landfill, LLC.  
Mr. Jared Davis, Greenpointe Landfill, LLC.  
Ty Hawkins (HRP)

Attachment





MOVE YOUR ENVIRONMENT FORWARD

## GROUNDWATER DETECTION MONITORING PLAN – 2015 UPDATE

### **Greenpointe C&D Landfill (Permit: LF2-00001)**

500 Hamlin Road  
Anderson, South Carolina

Prepared For:

Greenpointe Landfill  
c/o: Mr. Radford Jenkins  
P.O. Box 8028  
Greenville, SC 29604-8028

Prepared By:

HRP Associates, Inc.  
1327 Miller Road, Suite D  
Greenville, SC 29607

HRP #: GRE4714.GW

Issued On: August 24, 2015

**RECEIVED**

AUG 26 2015

DIVISION OF MINING &  
SOLID WASTE MANAGEMENT  
BLWW



**TABLE OF CONTENTS**

**1.0 INTRODUCTION .....1**

    1.1 Purpose ..... 1

    1.2 Site Location/Geography ..... 2

    1.3 Site Background ..... 2

**2.0 MONITORING WELL NETWORK: REVISED FALL 2015 .....3**

    2.2 Monitoring Well Network Expansion ..... 3

        2.2.1 Monitoring Well Abandonment..... 3

        2.2.2 Monitoring Well Installation ..... 3

        2.2.3 Monitoring Well Repair ..... 4

        2.2.4 Certified Land Survey..... 4

    2.3 New Monitoring Well Network (Fall 2015) ..... 4

**3.0 GROUNDWATER SAMPLE COLLECTION AND ANALYSIS PROTOCOL.....5**

    3.1 Determination of Groundwater Elevation ..... 5

    3.2 Groundwater Sampling Methodology..... 5

    3.3 Sample Analysis ..... 5

    3.4 Sample Handling Procedures ..... 5

    3.5 Sampling Equipment Decontamination Procedures..... 6

    3.6 Data Management Plan ..... 7

        3.6.1 Field Data Collection & Management..... 7

        3.6.2 Laboratory Data Collection & Management ..... 7

        3.6.3 Chain-of-Custody ..... 8

**4.0 QUALITY CONTROL SAMPLES.....9**

**5.0 REPORTING & MONITORING SCHEDULE ..... 10**

**6.0 REFERENCES..... 11**

**Figures**

- Figure 1 Site Location Map
- Figure 2 Site Map & Monitoring Locations (Fall 2015)
- Figure 3 Certified Land Survey

**Appendices**

- Appendix A Well Construction Details
- Appendix B SCDHEC 1903 Forms
- Appendix C Groundwater Monitoring Well Development Logs
- Appendix D Supporting Documentation



**General Information**

**Project/Site Information:**

Greenpointe Landfill  
500 Hamlin Road  
Anderson, SC

**Consultant Information:**

HRP Associates, Inc.  
1327 Miller Road, Suite D  
Greenville, SC 29607  
Phone: 864-289-0311  
Fax: 864-281-9846  
E-mail: ty.hawkins@hrpassociates.com  
Project Number: GRE4714.GW.P1

**Client Information:**

Mr. Radford Jenkins  
P.O. Box 8028  
Greenville, SC 2964-8028

**Report Date:** 8/24/2015

**Report Author:**

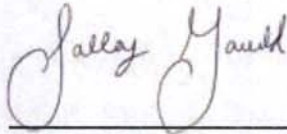

Salley Gould  
Project Geologist, GIT #26

**Senior Review:**



Shaun C. Malin  
Project Manager, P.G. #2454

**Client Manager:**

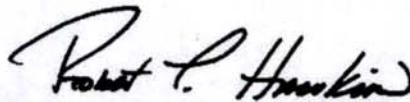

Robert "Ty" Hawkins  
Project Manager



## 1.0 INTRODUCTION

---

HRP Associates, Inc. (HRP) has prepared the following Groundwater Detection Monitoring Plan, on behalf of Greenpointe C&D Landfill (Greenpointe), for the facility located at 500 Hamlin Road, Anderson, South Carolina (the Site) (**Figure 1**).

Greenpointe is in the process of expanding the landfill footprint into Cell 2 (**Figure 2**) in accordance with their previously approved permit. As such, the current groundwater network warrants modification to continue to monitor the landfill in accordance with the SCDHEC Regulation R.61-107.19, the Class 2 Landfill Permit#LF2-00001, and yet still allow the landfill to effectively conduct its operations. This 2015 Groundwater Detection Monitoring Plan will be initiated during the Annual (fall) 2015 groundwater monitoring event.

The following actions occurred, to modify the groundwater network:

- Abandonment of three (3) existing groundwater monitoring wells: two (2) within Cell 2 (PZ-2 and PZ-9) and one (1) within Cell 3 (PZ-3);
- Installation of two (2) new groundwater monitoring wells east of Cell 2 and Cell 3 (PZ-11 and PZ-12);
- Installation of one (1) new groundwater monitoring well (PZ-13) along the border of Cell 2 and Cell 3;
- Lowering the elevation of two (2) groundwater monitoring wells (PZ-5 and PZ-8) to be accessible for groundwater sampling;
- The addition of three (3) existing groundwater monitoring wells (PZ-3, PZ-8, and PZ-5) to the landfill's groundwater monitoring network. Of note, these three (3) wells are currently in-place, but have not been monitored as part of the 2009 Groundwater Monitoring System Design Report (GWSDR); and,
- Conduct a Site survey by a certified land surveyor of all Site groundwater monitoring wells.

Upon completion of the aforementioned modifications, the new landfill groundwater monitoring network will include the following seven (7) monitoring wells:

- PZ-1: up-gradient of the disposal unit and is considered a background well;
- PZ-10 and PZ-11: down-gradient of Cell 1; and,
- PZ-5, PZ-8, PZ-12, and PZ-13: down-gradient of Cell 2.

### 1.1 Purpose

This Groundwater Detection Monitoring Plan describes the updated methods and protocol from the Davis and Floyd October 2009 *Groundwater Detection Monitoring Plan* as previously approved by SCDHEC on October 19, 2009 following the expansion of the landfill footprint into Cell 2. This document specifies the future protocol which will be utilized to monitor groundwater during the operation of Greenpointe Landfill.



## 1.2 Site Location/Geography

The Site is located approximately nine (9) miles north of Williamston, South Carolina on Hamlin Road in Anderson County, South Carolina (Figure 1) and comprises a total of 195 acres. Adjacent properties to the landfill are sparsely populated and primarily used for agricultural purposes or undeveloped land. The majority of the area within one-quarter mile of the Site is comprised of undeveloped woods. A Site map is presented as **Figure 1**.

The topography within the facility boundary generally slopes to the south at elevations ranging from 800 to 860 feet above mean sea level. The landfill boundary is greater than 200 feet from the edge of Pickens Creek (located along the south side of the Site) and a tributary of Pickens Creek (along the east side of the Site).

## 1.3 Site Background

Eight (8) piezometers were installed around the proposed landfill area in July 2005. These piezometers were installed to depths ranging from 15-30 feet below ground surface.

A *Groundwater Monitoring System Design Report* was submitted to SCDHEC on May 21, 2009. This document detailed Site aquifer information and also proposed the number and location of groundwater monitoring wells needed to sufficiently monitor the underlying aquifer. Subsequently, a *Groundwater Detection Monitoring Plan* was submitted in August 2009 and a *Revised Groundwater Detection Monitoring Plan* was submitted and approved by SCDHEC on October 19, 2010. The *Revised Groundwater Detection Monitoring Plan* detailed Greenpointe landfill's plans to evaluate the Sites groundwater in accordance with South Carolina Regulation 61-107-.19 through the use of a monitoring network. This plan has been in place and executed since April 2010.

## **2.0 MONITORING WELL NETWORK: REVISED FALL 2015**

---

### **2.1 2009 – April 2015 Monitoring Well Network**

As per the *2009 Groundwater Monitoring System Design Report*, the initial groundwater monitoring well network consisted of four (4) monitoring locations, which were sampled semi-annually.

1. Monitoring point PZ-1 is located up-gradient of the disposal unit and is considered a background well;
2. PZ-9 is located along the southeastern boundary of the disposal unit;
3. PZ-2 is centrally located along the southern boundary of the disposal unit; and
4. PZ-10 is located along the southwestern boundary of the disposal unit.

### **2.2 Monitoring Well Network Expansion**

In accordance with SCDHEC's approval letter dated April 8, 2015, HRP conducted the following activities.

#### **2.2.1 Monitoring Well Abandonment**

The expansion of the landfill footprint into Cell 2 required the abandonment of the three (3) existing monitoring wells; two (2) within Cell 2 (PZ-2 and PZ-9) and one (1) within Cell 3 (PZ-3). These monitoring wells were abandoned by a licensed well driller in accordance with South Carolina Well Standards (R.61-71). Portland cement was used to fill the total volume of each well using forced injection by tremie pipe from bottom to top. All aboveground well materials (stick-up vaults, casings and pads) were removed and filled with native soil to the level of the surrounding ground surface.

#### **2.2.2 Monitoring Well Installation**

Two (2) new down-gradient monitoring wells (PZ-11 and PZ-12) were installed in strategic positions along the eastern landfill boundary to monitor groundwater quality in this area. PZ-11 was installed down-gradient and southeast of Cell 1 and PZ-12 was installed within 150 feet and down-gradient southeast of Cell 2. Additionally, a third new down-gradient monitoring well, MW-13, was installed just down-gradient of Cell 2.

The new monitoring wells were installed by a licensed well driller in accordance with South Carolina Well Standards described in R.61-71 and South Carolina Solid Waste Management Regulations R.61-107.19.

Groundwater monitoring wells were installed using a hollow-stem auger (HSA) #CP-1100E drill rig. All newly installed groundwater monitoring wells were constructed of 2-inch PVC risers with ten (10) foot 0.010-slot screened intervals. Filter-pack was composed of silica sand and extended two (2) feet above the top of the screened interval. The filter-pack was followed by two (2) feet of hydrated bentonite chips and then tremie grouted to the ground surface. Each monitoring well was completed with a stick-up well cover set in a 2' x 2' concrete pad. Well installation logs and

SCDHEC 1903 forms are presented in **Appendices A** and **B**, respectively. Monitoring well development logs are presented in **Appendix C**.

### **2.2.3 Monitoring Well Repair**

As part of the landfill's expansion into Cell 2, grading was conducted in the area of PZ-5 and PZ-8. This grading resulted in wells being elevated approximately 8 feet above the surrounding grade. As such, the stick-up casing on wells PZ-5 and PZ-8 was lowered to the ground surface to be accessible for groundwater sampling. After being lowered, a new well pad was installed for each well. The top of casing was then resurveyed, as detailed in Section 2.2.4.

### **2.2.4 Certified Land Survey**

A Site survey was conducted by a certified land surveyor, upon the completion of well construction activities, and is included as **Figure 3**.

## **2.3 New Monitoring Well Network (Fall 2015)**

Beginning with the annual 2015 groundwater sampling event (September 2015), the new landfill groundwater monitoring network will include the following seven (7) monitoring wells.

- PZ-1: up-gradient of the disposal unit and is considered a background well;
- PZ-10 and PZ-11: down-gradient of Cell 1; and,
- PZ-5, PZ-8, PZ-12, and PZ-13: down-gradient of Cell 2.

Two (2) existing groundwater wells (PZ-5 and PZ-8) were added to the groundwater monitoring network. These two wells were installed as part of the initial feasibility assessment of landfill, but have not historically been monitored as part of the landfills groundwater monitoring network. PZ-8 is located 43 feet down-gradient of Cell 2. PZ-5 is located west of Cell 3 along the landfill's western boundary. Each of these wells is located down-gradient of the active disposal unit and will be utilized to evaluate potential impact to the underlying shallow aquifer.

This monitoring system will provide groundwater quality data to detect a potential impact to groundwater. The new groundwater monitoring well network will continue to be sampled on a semi-annual basis in accordance with this updated plan. Monitoring well locations are depicted in **Figure 2**.

### **3.0 GROUNDWATER SAMPLE COLLECTION AND ANALYSIS PROTOCOL**

All pertinent sampling, analysis, and field procedures are adopted from the U.S. EPA Region IV, Science and Ecosystem Support Division (SESD) Operating Procedure as referenced throughout the following sections. Please refer to the aforementioned publicly available documents where procedures are not specified.

#### **3.1 Determination of Groundwater Elevation**

Depth-to-water measurements will be recorded at groundwater monitoring wells on a semi-annual basis. Total well depths will also be recorded annually to check for the potential build-up of sediment in the wells. Measurement procedures are based on applicable guidelines of *Groundwater Level and Well Depth Measurement*, U.S. EPA Science and Ecosystem Support Division (SESD) Operating Procedure (SESDPROC-105-R1), EPA Region IV, November 1, 2007.

#### **3.2 Groundwater Sampling Methodology**

HRP will utilize a low-flow sampling technique to obtain geochemical parameters (pH, specific conductivity, temperature, etc.), and groundwater samples from specific Site monitoring wells. The purpose of low-flow sampling is to minimize persistent turbidity. Well purging procedures are based on applicable guidelines of *Groundwater Sampling* of the SESD Operating Procedure (SESDPROC-301-RI), EPA Region IV, November 1, 2007.

Ultimately, groundwater purging and/or sampling methods (e.g., submersible pump, bailer, etc.) will be left to the discretion of the sampling team leader and may vary based on 1) the volume of water to be purged, 2) depth to water, 3) field and equipment conditions, and 4) logistics. The actual purge method used will be recorded on the HRP well sampling log.

#### **3.3 Sample Analysis**

Groundwater samples will continue to be analyzed for Site constituents of concern as defined in the October 2009 Groundwater Detection Monitoring Plan:

- VOCs via EPA Method 8260;
- Nitrate, sulfate and chloride will be analyzed by methods EPA 9056;
- Mercury via EPA Method 7470; and,
- Metals (As, Ba, Cd, Cr, Pb, Hg, Se, Ag) by EPA method 6010A.

#### **3.4 Sample Handling Procedures**

All samples to be analyzed will be stored on ice in an insulated cooler while in the field and in a manner that protects the sample from breakage. The samples will be transferred to a laboratory upon completion of the monitoring event. A chain-of-custody form will accompany the samples from the time of collection until they are received by the laboratory. Each party in possession of the samples will be required to sign the chain-of-custody form signifying receipt. The completed form will be provided by the laboratory along with the report of analysis results. These procedures are based on applicable guidelines of the *Packing, Marking, Labeling and Shipping of*

*Environmental and Waste Samples* of the SESD Operating Procedure (SESDPROC-209-R1), EPA Region IV, November 1, 2007.

Sample containers, will be free of foreign substances, particularly substances that will change sample quality or interfere with required analyses. Stick-on labels will be affixed to all containers.

### **3.5 Sampling Equipment Decontamination Procedures**

Where possible, all sampling equipment will be washed and prepared in the laboratory prior to use in the field.

The following cleaning procedures for Teflon, glass, or stainless-steel sampling equipment used for the collection of samples for VOC analyses are based on applicable guidelines of the *Field Equipment Cleaning and Decontamination at the FEC* of the SESD Operating Procedure (SESDPROC-206-RI), EPA Region IV, November 1, 2007:

1. Wash equipment thoroughly with laboratory phosphate-free detergent and hot water using a brush to remove any particulate matter or surface film;
2. Rinse equipment thoroughly with hot tap water;
3. Rinse equipment thoroughly with organic/analyte free water. Organic/analyte free water is defined as tap water that has been treated with activated carbon and de-ionizing units. If transported for use in the field, the organic-free water should be stored in properly prepared and labeled "organic-free water only" containers and used within three (3) days of preparation.
4. Wrap equipment in one layer of aluminum foil. Roll edges of foil into a "tab" to allow for easy removal.

The following procedures are based on applicable guidelines of the *Field Equipment Cleaning and Decontamination* of the SESD Operating Procedure (SESDPROC-205-RI), EPA Region IV, November 1, 2007. If necessary, Teflon, glass, stainless steel, or metal equipment used to collect samples for VOC analyses may be decontaminated in the field using the following procedures:

1. Clean with tap water and laboratory phosphate-free detergent using a brush if necessary to remove particulate matter and surface films;
2. Rinse thoroughly with tap water;
3. Rinse thoroughly with organic/analyte free water. Organic-free water is defined as tap water that has been treated with activated carbon and de-ionizing units. If transported for use in the field, the organic-free water should be stored in properly prepared and labeled "organic free water only" containers and used within three (3) days of preparation. If organic/analyte free water is not available, allow equipment to air dry as long as possible after the solvent rinse;

4. Wrap with aluminum foil, if appropriate, to prevent contamination if equipment is going to be stored or transported.

### **3.6 Data Management Plan**

The following procedures are based on applicable guidelines of the *Sample and Evidence Management* of the SESD Operating Procedure (SESDPROC-005-RI), EPA Region IV, November 1, 2007.

#### **3.6.1 Field Data Collection & Management**

Field personnel are responsible for uniquely identifying and labeling samples, providing proper preservation, packaging samples to prevent breakage during shipment, and initiating the chain-of-custody form.

Proper sample identification is an essential part of any field sampling project. Because of its importance to accurate data acquisition, documentation and labeling of samples in the field is necessary. Each sample shall be identified on the sample container label and include the following information:

1. Date and time;
2. Sample identification number;
3. Project name and number;
4. Sampler name;
5. Sample location;
6. General analyses to be performed;
7. Designation as either grab or composite sample;
8. Preservative.

#### **3.6.2 Laboratory Data Collection & Management**

Data to be retained by the laboratory include the following items:

1. Chain-of-custody forms;
2. Laboratory notes;
3. Internal laboratory performance audits;
4. Chromatograms;
5. Raw data printouts;
6. Tabulated data printouts;
7. Laboratory QA/QC data.

### 3.6.3 Chain-of-Custody

An accurate record of sample collection, transport, analysis and disposal will be maintained and documented. In addition, chain-of-custody procedures will be instituted and followed throughout the sampling program. The chain-of-custody form shall be signed by each individual who has the samples in his or her possession until delivery to the laboratory. The laboratory shall not accept samples for analysis without a correctly prepared chain-of-custody form. The laboratory shall be responsible for maintaining chain-of-custody of the samples.

#### 4.0 **QUALITY CONTROL SAMPLES**

---

To obtain a quantitative measure of the reproducibility of the sampling and analysis results (i.e., to assess precision and accuracy), quality control (QC) samples will be collected in the field or supplied by the laboratory as appropriate. The type and number of QC samples are dependent on the variability of the matrix being sampled, the sampling methodology, and the objectives of the data collection activity. The collection of QC samples will be based on applicable guidelines of the *Field Sampling Quality Control* of the SESD Operating Procedure (SESDFPROC-OII-R2), EPA Region IV, January 28, 2008. All QC samples will be analyzed for VOCs.

The following QC samples will continue to be collected throughout a routine monitoring event:

- One (1) trip blank for every day of sampling; and,
- One duplicate for every ten (1) groundwater samples.



## 5.0 **REPORTING & MONITORING SCHEDULE**

---

The next groundwater monitoring event will take place during the third quarter of 2015. In accordance with this 2015 Update, an annual Groundwater Monitoring Report summarizing the information collected during the previous year will be submitted on or before October 15.

The Annual Groundwater Monitoring Report will include the following:

- Monitoring data, including groundwater levels and groundwater analytical results;
- Hydrogeological review and summary;
- Data Analysis (gradients, trends, degradations, flow rates, etc.);
- Site location and groundwater flow contour maps; and,
- A determination of monitoring system adequacy.

A Semi-Annual Groundwater Monitoring Report, consisting of an analytical data report, shall be submitted on or before April 15 of each reporting year.

## 6.0 REFERENCES

---

Landfill Permit: LF-00002

SCDHEC, Oberly, David. April 8, 2015. Proposed Groundwater Monitoring Network Modifications. Greenpointe Class 2 Landfill, Anderson, SC.

Davis & Floyd, Inc. May 21, 2009. Groundwater Monitoring System Design Report. Greenpointe Class 2 Landfill, Anderson, SC.

Davis & Floyd, Inc. August 3, 2009. Groundwater Monitoring Detection Monitoring Plan. Greenpointe Class 2 Landfill, Anderson, SC.

# FIGURES

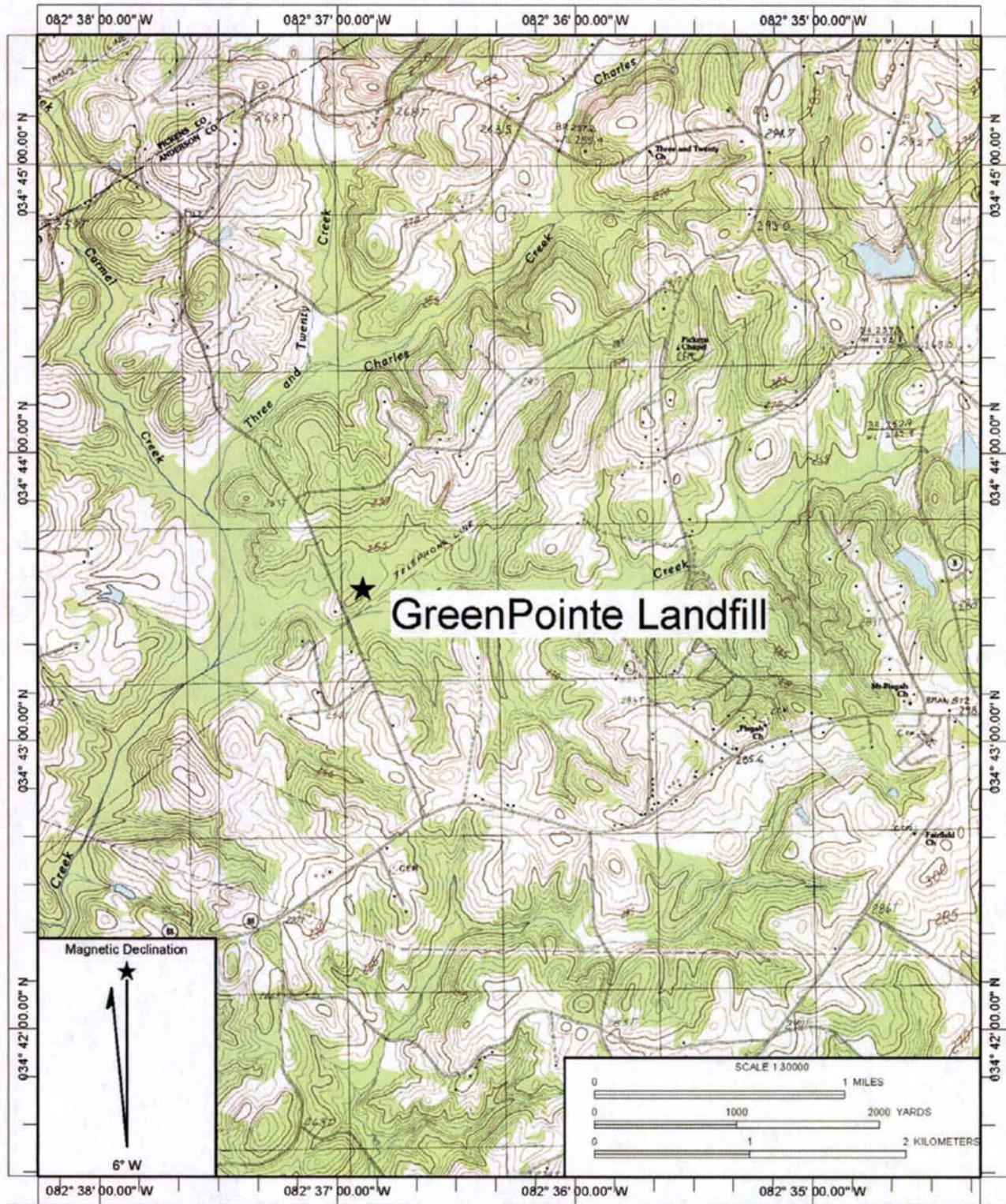

**Figure 1**  
**Site Location**  
**500 Hamlin Road**  
**Easley, SC**  
**Scale: 1" = 2,500'**

**HRP**  
 MOVE YOUR ENVIRONMENT FORWARD  
 1327 MILLER ROAD  
 SUITE D  
 GREENVILLE, SC 29607  
 (864) 289-0311  
 HRPASSOCIATES.COM

No.	Date	Revisions

Designed By:	SVG
Drawn By:	DML
Reviewed By:	RTH

Issue Date:	08/03/2015
Project No:	GRE4714.GW
Sheet Size:	11x17

**Site Plan**  
 GreenPointe Landfill  
 500 Hamlin Road  
 Easley, South Carolina

**FIGURE NO.**  
**2**

**Legend**

- ◆ Groundwater Monitoring Network Well
- ⊕ Piezometer (not currently monitored)
- General Landfill Footprint
- Approximate Cell Boundaries
- Approximate Property Line
- 100 Year Flood Line
- ▭ On-site buildings

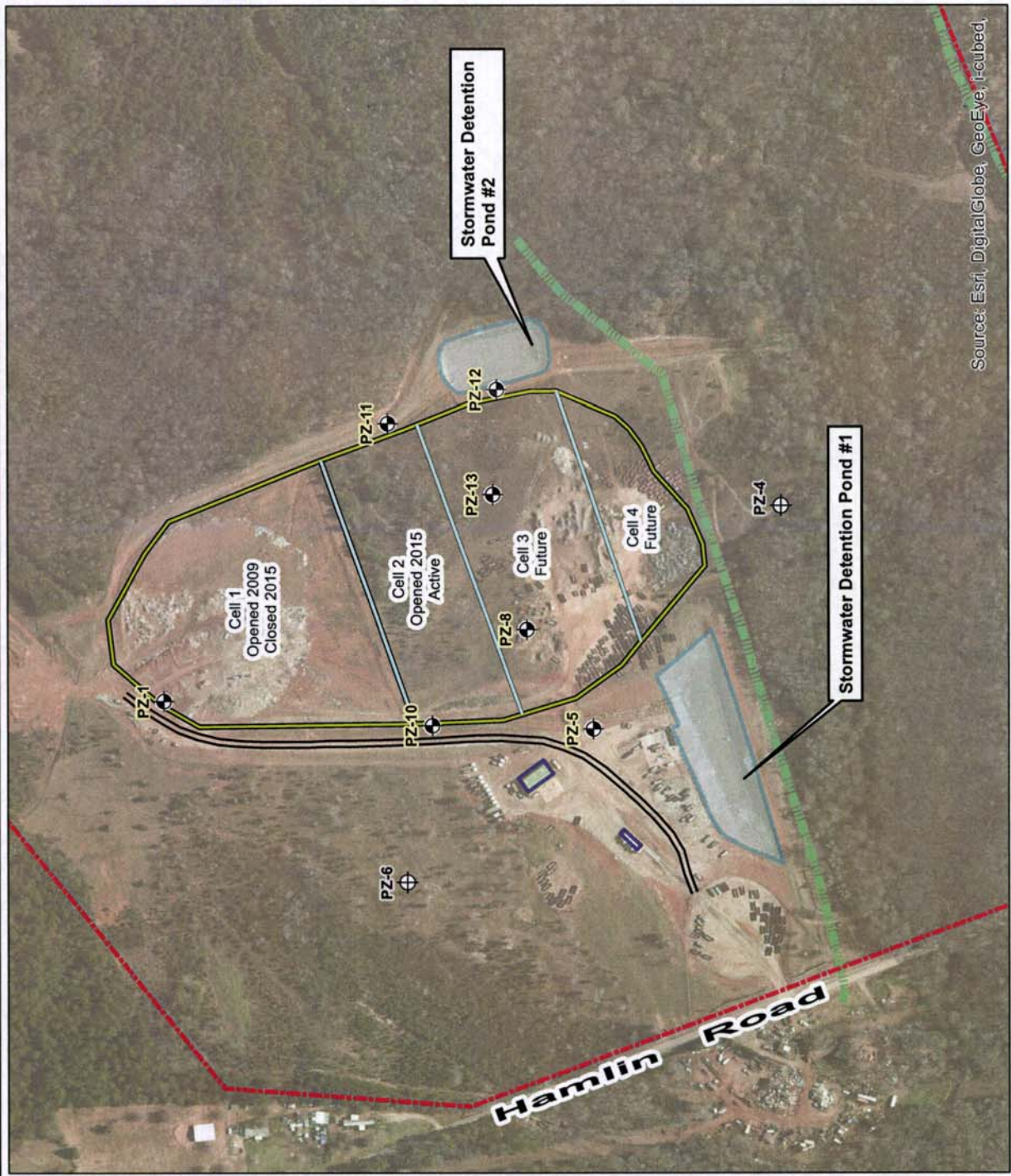

Source: Esri, DigitalGlobe, GeoEye, Earthstar, etc.



# APPENDIX A

## Well Construction Details



# BORING LOG

Project #: GRE4712.GW	ID: PZ-11
Rig Type: Geoprobe 7822 DT	Sheet: 1 of 1
SC PG: Shaun Malin #2454	Date Initiated: 06/18/15
Project Name: Greenpointe Landfill	Date Completed: 06/18/15
Location: 500 Hamlin Road, Easley, SC	Coordinates: _____
Method: Hollow Stem Augers	
Field Party: MP	
Weather: Sun, 85 degrees F	

Sampling Data						Well Schematic	Key		Well Completion Details		Water Levels	
Stratigraphy	USGS Class	Recovery (%)	Visible Contamination	Odor	Depth in Feet		Grout	Well Diameter: 2 inches	Total Depth: 20 feet bgs		Water level encountered during drilling: ▼	
							Sand	Screened Interval: 10-20 feet	Screen Slot: 0.01 foot		Static water level: ▼	
							Well Screen	Driller: SAEDACCO				

Stratigraphy	USGS Class	Recovery (%)	Visible Contamination	Odor	Depth in Feet	Well Schematic	Description
	CL/ML	NA	N	N	0-5'	0 2 4 6 8 10 12 14 16 18 20	0-5': Brown silty clay, no muscovite present, no moisture, no odor.
	CL/ML	NA	N	N	5-10'	10 12 14 16 18 20	5-10': Light brown silty clay, no muscovite, increase in clay content from 0-5' bgs, no moisture from 5-8' bgs, slight moisture 8-10' bgs, no odor.
	CL/ML	NA	N	N	10-15'	10 12 14 16 18 20	10-15': Light brown silty clay, abundant muscovite, shiny appearance, moist 10-11' bgs, wet at 11' bgs, no odor.
	CL/ML	NA	N	N	15-20'	10 12 14 16 18 20	15-20': Light brown silty clay, abundant muscovite, wet, no odor. Well set at 20' bgs. Sand at 8-20' bgs, bentonite 6-8' bgs, grout 0-6' bgs.





# BORING LOG

Project #:	GRE4712.GW	ID:	PZ-12
Rig Type:	Geoprobe 7822 DT	Sheet:	1 of 1
SC PG:	Shaun Malin #2454	Date Initiated:	06/17/15
Project Name:	Greenpointe Landfill	Date Completed:	06/17/15
Location:	500 Hamlin Road, Easley, SC	Coordinates:	
Method:	Hollow Stem Augers		
Field Party:	MP		
Weather:	Sun, 85 degrees F		

Sampling Data							Well Schematic	Key		Well Completion Details		Water Levels	
Stratigraphy	USGS Class	Recovery (%)	Visible Contamination	Odor	PID (ppm)	Depth in Feet		Grout	Bentonite	Well Diameter:	2 inches	Water level encountered during drilling:	▼

Stratigraphy	USGS Class	Recovery (%)	Visible Contamination	Odor	PID (ppm)	Depth in Feet	Well Schematic	Description
	CL/ML	NA	N	N	119	0-4'		0-5': Brown silty clay, muscovite (> 1mm) present, no moisture, no odor. Transition to dark gray silty clay at 4' with slight moisture, clay % increased from 0-4' bgs, no odor.
	CL/ML	NA	N	N	135	5-10'		5-10': Grey brown silty clay, silt % increases, moist, more muscovite than above 0-5' bgs, soil has a shiny appearance, no odor.
	CL/ML	NA	N	N	179	10-15'		10-15': Grey brown silty clay, water approximately 10.5-11' bgs, abundant muscovite, no odor.
	CL/ML	NA	N	N	49	15-20'		15-20': Grey silty clay, very wet, no odor. Well set at 20' bgs. Screen from 10-20' bgs; sand from 8-20' bgs; bentonite from 6-8' bgs, Grout from 0-6' bgs.





# BORING LOG

Project #:	GRE4712.GW	ID:	PZ-13
Rig Type:	Geoprobe 7822 DT	Sheet:	1 of 1
SC PG:	Shaun Malin #2454	Date Initiated:	06/17/15
Project Name:	Greenpointe Landfill	Date Completed:	06/17/15
Location:	500 Hamlin Road, Easley, SC	Coordinates:	
Method:	Hollow Stem Augers		
Field Party:	MP		
Weather:	Sun, 85 degrees F		

Sampling Data							Well Schematic	Key	Well Completion Details	Water Levels
Stratigraphy	USGS Class	Recovery (%)	Visible Contamination	Odor	PID (ppm)	Depth in Feet		Grout	Well Diameter: 2 inches	Water level encountered during drilling: ▼
								Bentonite	Total Depth: 20 feet bgs	
								Sand	Screened Interval: 10-20 feet	
								Well Screen	Screen Slot: 0.01 foot	Static water level: ▼
									Driller: SAEDACCO	

Stratigraphy	USGS Class	Recovery (%)	Visible Contamination	Odor	PID (ppm)	Depth in Feet	Well Schematic	Description
	CL/ML	NA	N	N	490	0-5'		0-5': Light brown silty clay, small (<1 mm) flakes of muscovite. 3' bgs begin stration to increased clay content and slight color change to sandy brown, fewer muscovite than above, no odor, dry.
	CL/ML	NA	N	N	447	5-10'		5-10': Sany brown silty clay, clay % decreasing over the 5' interval, soil is very compacted, more silt than 0-5'; no odor, dry.
	CL/ML	NA	N	N	642	10-15'		10-15': Sandy brown silty clay, increase in moisutre content, water table approximately 10.5-11' bgs.
	CL/ML	NA	N	N	429	15-20'		15-20': Sandy brown silty clay, wet, no odor. Well set at 20' bgs. Screen from 10-20' bgs; sand from 8-20' bgs, bentonite 6-8' bgs; grout 0-6' bgs.

# APPENDIX B

## SCDHEC 1903 Forms



















# APPENDIX C

## Monitoring Well Development Logs

### Meter Calibration Sheet

HRP Job # : \_\_\_\_\_  
 Description: Development  
 Location: GreenPoint Landfill

#### pH (standard units)

Date: 8-13-15 Analyst: GSC  
 Time: 9:40 Meter Serial No: 1254770

Actual pH	Lot Number	Expiration Date	Measured (SU)*	Mid-Day Reading (7.0)	End of Day Reading (7.0)
4.00	4AG250	Jul-16	4.01		
7.00	4AG649	Jul-16	7.02		
10.00	3AH644	Aug-15	10.03		
7.00**	4AG649	Jul-16	7.03		

\* Only report pH units to 0.1  
 \*pH reading must be within  $\pm 0.1$  standard units  
 \*\* - QC check for pH reading must be within  $\pm 0.1$  standard units

Comments: \_\_\_\_\_  
 \_\_\_\_\_

#### Conductivity (uS/cm)

Date: 8-13-15 Analyst: GSC  
 Time: 9:40 Meter Serial No: 198223

Actual Conductivity (uS/cm)	Lot Number	Expiration Date	Measured
84	4A1376	Sep-15	85.2
1413	4AH987	Aug-15	1405
447 (Verification only)	4AH664	Aug-15	422

\*Conductivity reading must be within  $\pm 10\%$

Comments: \_\_\_\_\_  
 \_\_\_\_\_

#### Turbidity (NTU)

Date: 8-13-15 Analyst: GSC  
 Time: 9:40 Meter Serial No: 20110089

Actual Turbidity (NTU)	Lot Number	Expiration Date	Measured	Mid-Day Reading (7.0)	End of Day Reading (7.0)
1000	40703	Jul-16	997.3		
10.0	40763	Jul-16	10.01		
0.02	40701	Jul-16	0.01		

\*Turbidity reading must be within  $\pm 10\%$

Comments: \_\_\_\_\_  
 \_\_\_\_\_

### Meter Calibration Sheet

HRP Job #: \_\_\_\_\_  
 Description: \_\_\_\_\_  
 Location: Greenpoint Landfill

#### pH (standard units)

Date: 8/13/15 Analyst: SG  
 Time: 0938 Meter Serial No: 3513430

Actual pH	Lot Number	Expiration Date	Measured (SU)*	Mid-Day Reading (7.0)	End of Day Reading (7.0)
4.00	4AG250	Jul-16	4.01		
7.00	4AG649	Jul-16	7.00		
10.00	3AH644	Aug-15	10.02		
7.00**	4AG649	Jul-16	7.01		

\* Only report pH units to 0.1  
 \*pH reading must be within  $\pm 0.1$  standard units  
 \*\* QC check for pH reading must be within  $\pm 0.1$  standard units

Comments: \_\_\_\_\_  
 \_\_\_\_\_

#### Conductivity (uS/cm)

Date: 8/13/15 Analyst: SG  
 Time: 0938 Meter Serial No: 1540660

Actual Conductivity (uS/cm)	Lot Number	Expiration Date	Measured
84	4A1376	Sep-15	84.0
1413	4AH987	Aug-15	1419
447 (Verification only)	4AH664	Aug-15	470

\*Conductivity reading must be within  $\pm 10\%$

Comments: \_\_\_\_\_  
 \_\_\_\_\_

#### Turbidity (NTU)

Date: 8/13/15 Analyst: SG  
 Time: 0945 Meter Serial No: 20061240

Actual Turbidity (NTU)	Lot Number	Expiration Date	Measured	Mid-Day Reading (7.0)	End of Day Reading (7.0)
1000	40703	Jul-16	998.3		
10.0	40763	Jul-16	10.10		
0.02	40701	Jul-16	0.02		

\*Turbidity reading must be within  $\pm 10\%$

Comments: \_\_\_\_\_  
 \_\_\_\_\_

HRP Associates, Inc.  
1327 Miller Road  
Greenville, SC 29607

## Monitoring Well Development Log

Project/No. GRE4714, GW Well P2-11 Date 8/13/15

Total Depth 23.32 Casing Diameter (inches) 2" Purge Method Centrifugal

Water Level 6.94 Well Volume (gal) 2.7 Submersible

Water Column 16.38 Total Volume Purged 38 391 Other \_\_\_\_\_

Pump On 1013 Pump Off 1233 Developed By GSC

**Well Casing Volumes**

gallon/foot	1-1/4" = 0.06	2" = 0.16	3" = 0.37	4" = 0.65
	1-1/2" = 0.09	2-1/2" = 0.26	3-1/2" = 0.50	6" = 1.47

well wet  
dry

Time	Minutes Elapsed	Rate (gpm) (mL/min)	DTW (ft)	Gallons Purged	pH	Specific Conductance (mS/cm)	Temp. (C) (F)	DO (mg/L)	OPR	Turbidity (NTU)
1013	0	-	6.94	0	5.35	60.0	19.9	-	-	>1100
1017	4	-		3	5.07	61.2	20.7	-	-	909.6
1021	8	-		6	5.03	61.6	20.1	-	-	65.08
1026	13	-		9	5.03	55.8	19.7	-	-	829.3
1030	17	-		12	4.91	45.7	19.4	-	-	619.7
1035	22	-		15	5.05	39.8	18.7	-	-	>1100
1037	well DRY			waited 10 mins		<del>was wet</del>				
1050	47	-		20	5.22	40.9	21.0	-	-	>1100
1051	well wet DRY			<del>22 5.36 38.5 20.0</del>						
1113		-		23	5.36	38.5	20.0	-	-	>1100
1116	well wet DRY			<del>24 5.47 46.1 21.1</del>						
1130		-		26	5.47	46.1	21.1	-	-	118.4
1141		-		29	4.98	44.3	19.6	-	-	>1100
1141	well wet dry			waited 10 mins						
1153		-		32	4.94	26.5	20.2	-	-	>1100
1154	well wet dry			waited 30 mins						
1230		-		35	5.16	26.7	22.5	-	-	67.72
1233		-		38	4.75	26.7	19.7	-	-	978.2

⊙







# APPENDIX D

## Supporting Documentation



March 23, 2015

Mr. David Oberly II  
SCDHEC - BLWM  
2600 Bull Street  
Columbia, SC 29201

RE: PROPOSED GROUNDWATER MONITORING NETWORK MODIFICATIONS  
GREEN POINTE C&D LANDFILL (#LF2-00001)  
500 HAMLIN ROAD, EASLEY, ANDERSON COUNTY, SC  
(JOB#GRE4713.GW)

Dear Mr. Oberly:

On behalf of Green Pointe Landfill, HRP Associates, Inc. (HRP) is seeking South Carolina Department of Health and Environmental Control (SCDHEC) approval to alter and expand the current on-site groundwater monitoring network. Green Pointe Landfill is expanding the landfill footprint into Cell 2 (**Attachment 1**) in accordance with their previously approved permit. As such, the current groundwater network warrants modification to continue to monitor the landfill in accordance with the SCDHEC Regulation R.61-107.19, the Class 2 Landfill Permit #LF2-00001, and yet still allow the landfill to effectively conduct its operations. To modify the groundwater monitoring network, HRP proposes the following:

- Abandonment of the two (2) existing groundwater monitoring wells within Cell 2 (PZ-2 and PZ-9);
- Installation of two (2) new groundwater monitoring wells east of Cell 2 and Cell 3 (PZ-11 and PZ-12); and,
- The addition of three (3) existing groundwater monitoring wells (PZ-3, PZ-8, and PZ-5) to the landfill's groundwater monitoring network. Of note, these three wells are currently in-place, but not currently monitored as part of the landfill's groundwater monitoring network.

The expansion of the landfill footprint into Cell 2 requires the abandonment of the two (2) existing monitoring wells (PZ-2 and PZ-9) within cell 2. These monitoring wells will be abandoned by a licensed well driller in accordance with South Carolina Well Standards (R.61-71). Portland cement will be used to fill the total volume of each well using forced injection by tremie pipe from bottom to top. All aboveground well materials (stick-up vaults, casings and pads) will be removed and filled with native soil to the level of the surrounding ground surface. Approximately 47 feet of well footage will be abandoned.

Two (2) new down-gradient monitoring wells (PZ-11 and PZ-12) will be installed in strategic positions along the eastern landfill boundary to monitor groundwater quality in this area. PZ-11 will be installed immediately down-gradient southeast of Cell 1 and PZ-12 will be installed

within 150 feet and down-gradient southeast of Cell 2. The proposed new monitoring wells will be installed by a licensed well driller in accordance with South Carolina Well Standards described in R.61-71 and South Carolina Solid Waste Management Regulations R.61-107.19. The wells will be 2-inch in diameter with 15-foot 10-slot screens. The exact depths and screened intervals will be dependent on Site lithology and depth to groundwater; however, based on existing wells, it is estimated that these monitoring wells will be installed to approximately 20 feet below ground surface. The SCDHEC Monitoring Well Applications are included as an attachment to this letter.

Three (3) additional existing groundwater wells (PZ-3, PZ-5, and PZ-8) will be added to the groundwater monitoring network. These three wells are currently in-place, but have not been monitored as part of the landfills groundwater monitoring network. PZ-3 and PZ-8 are located 196 and 43 feet down-gradient of Cell 2, respectively. PZ-5 is located west of Cell 3 along the landfill's western boundary. All three wells are located down-gradient of active disposal units and will be utilized to evaluate any potential impact to the underlying shallow aquifer.

As part of the utilization of PZ-5, this well will also be lowered to the current ground surface. Excavation in the area will require this well be cut to make accessible for sampling. After being cut, a new well pad will be installed and the TOC elevation will be surveyed to re-establish elevations to monitor site groundwater elevations.

Upon completion of the aforementioned modifications, the new landfill groundwater monitoring network will include the following seven (7) monitoring wells:

- PZ-1: up-gradient of the disposal unit and is considered a background well;
- PZ-10 and PZ-11: down-gradient of Cell 1; and,
- PZ-3, PZ-5, PZ-8, and PZ-12: down-gradient of Cell 2.

The groundwater new monitoring network will be sampled on a semi-annual basis in accordance with the SCDHEC approved October 19, 2009 Revised Groundwater Detection Monitoring Plan. Monitoring well locations are depicted in **Figure 1 (Attachment 1)**.

HRP will implement the aforementioned tasks immediately upon SCDHEC approval. If you have any questions or require additional information, please feel free to contact HRP at (864) 289-0311.

Sincerely,  
HRP Associates, Inc.

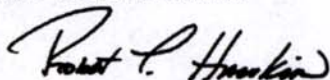

Robert T. Hawkins  
Project Manager



Mr. Oberly  
March 23, 2015  
Page 3

Attachments



# ATTACHMENT 1: PROPOSED GROUNDWATER MONITORING NETWORK



NO.	DATE	REVISIONS

DESIGNED BY:	RTH
DRAWN BY:	DML
REVIEWED BY:	RTH

ISSUE DATE:	03/23/2015
PROJECT NUMBER:	GRE4712.GW
SHEET SIZE:	11"x17"

**SITE PLAN WITH POTENTIOMETRIC GW CONTOURS**  
 GREENPONT  
 500 HAMLIN ROAD  
 ANDERSON COUNTY, SOUTH CAROLINA

**FIGURE NO. 1**

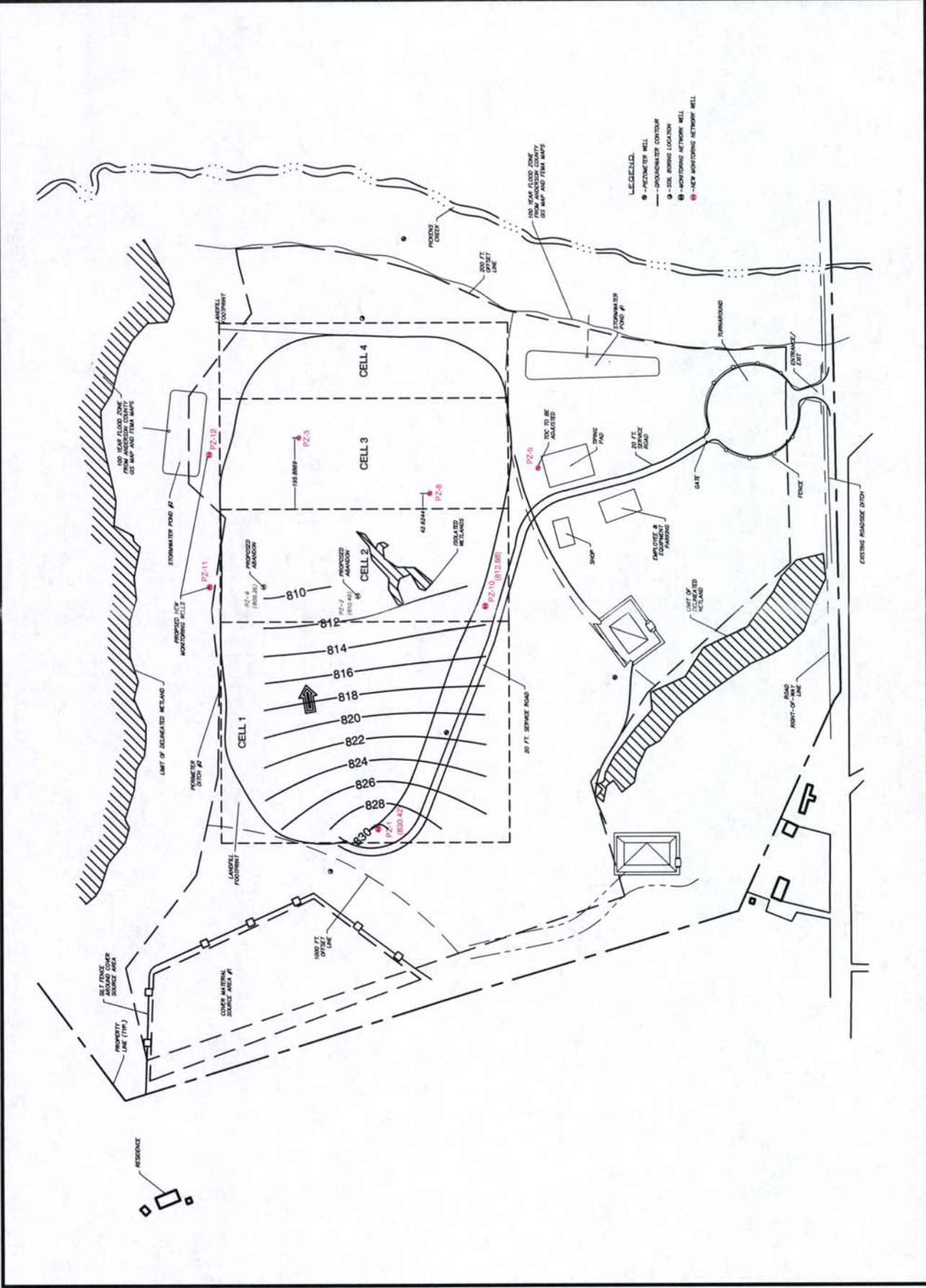

# ATTACHMENT 2:

## SCDHEC MONITORING WELL APPLICATION







# Monitoring Well Application

<p>1. Proposed Location of Monitoring Well(s):</p> <p>Street Address: <b>500 Hamlin Road</b></p> <p>City (including Zip): <b>Easley 29642</b></p> <p>County: <b>Anderson</b></p> <p>Please attach Scaled Map or Plat</p>	<p>5. Intended Purpose of Well(s):</p> <p>Pre-Purchase <input type="checkbox"/></p> <p>Investigation <input checked="" type="checkbox"/></p> <p>Program Area: <b>SCDHEC-BLWM</b></p> <p>Project or Site ID #: <b>#LF2-00001</b></p> <p><b>NOTE:</b> If this request is for an existing DHEC project, please enter the Program area and ID number below.</p>																										
<p>2. Well Owner's Information:</p> <p>Name (Last then First): <b>Jenkins, Radford</b></p> <p>Company: <b>Green Pointe Landfill</b></p> <p>Complete Address: <b>P.O. Box 8028 Greenville, SC 29604</b></p> <p>Telephone Number: <b>(864) 233-0100</b></p>	<p>6. Proposed number of monitoring wells: <b>3</b></p> <p>7. Proposed parameters to be analyzed (check all that apply), please specify analytical method beside check box:</p> <table><tr><td>VOCs</td><td><input checked="" type="checkbox"/></td></tr><tr><td>BTEX</td><td><input type="checkbox"/></td></tr><tr><td>MtBE</td><td><input type="checkbox"/></td></tr><tr><td>Naphthalene</td><td><input type="checkbox"/></td></tr><tr><td>PAHs</td><td><input type="checkbox"/></td></tr><tr><td>Metals</td><td><input checked="" type="checkbox"/></td></tr><tr><td>Nitrates</td><td><input checked="" type="checkbox"/></td></tr><tr><td>Base, Neutral &amp; Acid Ex.</td><td><input type="checkbox"/></td></tr><tr><td>Pesticides/Herbicides</td><td><input type="checkbox"/></td></tr><tr><td>Phenols</td><td><input type="checkbox"/></td></tr><tr><td>Radionuclides</td><td><input type="checkbox"/></td></tr><tr><td>PCBs</td><td><input type="checkbox"/></td></tr><tr><td>Other (specify below)</td><td><input checked="" type="checkbox"/></td></tr></table> <div style="border: 1px solid black; padding: 5px;"><p><b>Metals: Ba, As, Cd, Cr, Pb, Hg, Se, Ag Chloride &amp; Sulfate</b></p></div>	VOCs	<input checked="" type="checkbox"/>	BTEX	<input type="checkbox"/>	MtBE	<input type="checkbox"/>	Naphthalene	<input type="checkbox"/>	PAHs	<input type="checkbox"/>	Metals	<input checked="" type="checkbox"/>	Nitrates	<input checked="" type="checkbox"/>	Base, Neutral & Acid Ex.	<input type="checkbox"/>	Pesticides/Herbicides	<input type="checkbox"/>	Phenols	<input type="checkbox"/>	Radionuclides	<input type="checkbox"/>	PCBs	<input type="checkbox"/>	Other (specify below)	<input checked="" type="checkbox"/>
VOCs	<input checked="" type="checkbox"/>																										
BTEX	<input type="checkbox"/>																										
MtBE	<input type="checkbox"/>																										
Naphthalene	<input type="checkbox"/>																										
PAHs	<input type="checkbox"/>																										
Metals	<input checked="" type="checkbox"/>																										
Nitrates	<input checked="" type="checkbox"/>																										
Base, Neutral & Acid Ex.	<input type="checkbox"/>																										
Pesticides/Herbicides	<input type="checkbox"/>																										
Phenols	<input type="checkbox"/>																										
Radionuclides	<input type="checkbox"/>																										
PCBs	<input type="checkbox"/>																										
Other (specify below)	<input checked="" type="checkbox"/>																										
<p>3. Property Owner's Information:</p> <p><input checked="" type="checkbox"/> Check if same as Well Owner</p> <p>Name (Last then First):</p> <p>Company:</p> <p>Address:</p> <p>Telephone Number:</p>	<p>8. Proposed construction details (complete and attach proposed monitoring well schematics):</p>																										
<p>4. Proposed Drilling Date: <b>05/01/2015</b></p>																											

**South Carolina Department of Health and Environmental Control (SCDHEC) summary of standards for monitoring well construction (per South Carolina Well Standards and Regulations R. 61-71)**

**Approval and License Requirements**

Prior Department approval is required for the installation or abandonment of all monitoring wells including direct push, geoprobe or other temporary type monitoring wells. The attached monitoring well approval document should be completed, submitted and approved prior to construction of any monitoring well. A monitoring well is any well used to obtain water samples for water quality analyses or to measure groundwater levels. There are no fees for approvals. All monitoring wells must be drilled by a driller that is registered in South Carolina with the Board of Certification of the Environmental Systems Operators. If any of the information on the application including the proposed drilling date, well construction details or well placement changes, the Department (i.e. project manager issuing the well approval) must be notified 24 hours prior to well construction.

**Location**

Due to the nature and purpose of a monitoring well, the depth and location requirements in respect to surface water bodies, potential contamination sources, etc., are variable, and shall be approved on a case by case basis by the Department.

**Construction and Material**

Casing should be of sufficient strength to withstand normal forces encountered during and after well installation and be composed of material so as to minimally affect water quality analyses. Casing should have a sufficient diameter to allow for efficient sample collection (i.e., to provide access for sampling equipment). The diameter of the drilled hole needs to be large enough on all sides (1.5 inches of annular space) to allow forced injection of grout through a tremie pipe. All monitoring wells should have a cement pad or aggregate reinforced concrete at the ground surface which extends at least six inches beyond the bore hole diameter and six inches below ground surface to prevent infiltration between the surface casing and the bore hole. All monitoring wells should be grouted from the top of the bentonite seal to the surface with a neat cement, high solids bentonite or neat cement, bentonite mixture approved by the Department. A hydrated bentonite seal with a minimum thickness of 12 inches is to be placed above the filter pack to prevent infiltration of grout if the well has a filter pack. The monitoring well intake or screen design should minimize the amount of formational materials entering the well. The gravel pack should be utilized opposite the well screen as appropriate so that parameters analyses will be minimally affected. All monitoring wells should have a locking cap or other security device to prevent damage and/or vandalism. Any monitoring well which is destroyed, rendered unusable or is abandoned should be reported to the Department and be properly abandoned, revitalized or replaced as appropriate or required by permit or regulation.

**Development**

Monitoring wells shall be properly developed. Development shall include the removal of formation cuttings and drilling fluids from the well bore hole. Development shall be complete when the well produces water typical of the aquifer being monitored.

## **Reporting Requirements**

A monitor well record form (1903) or equivalent to include the following should be completed and submitted to the Department within 30 days after completion of the monitoring wells:

Name and address of facility/owner;  
Surveyed or global positioning system location of monitor well(s) on a scaled map or plat;  
Driller and certification number;  
Date drilled;  
Driller's or Geologist's log;  
Total depth;  
Screened interval;  
Diameter and construction details;  
Depth to water table with date and time measured;  
Surveyed elevation of measuring point with respect to established benchmark;  
Monitoring well approval number issued by the Department.

Additionally, the groundwater and soil (if taken) analytical results should be submitted to the Department within 30 days of receipt from the laboratory.

## **Abandonment**

All monitoring wells shall be properly abandoned, when deemed appropriate by the Department. Any well that acts as a source of contamination shall be repaired or permanently abandoned immediately after receipt of notice from the Department. Abandonment shall be by forced injection of grout or pouring through a tremie pipe starting at the bottom of the well and proceeding to the surface in one continuous operation. The well shall be filled with either neat cement, bentonite-cement, or 20% high solids sodium bentonite grout, from the bottom of the well to the land surface.

- \* This summary of standards for monitoring well construction may not include a listing of all information necessary to obtain an approval to install monitoring wells. Final approval of monitoring well installation will be dependant upon the regulatory requirements for the Department program area for which the monitoring wells are to be installed.
- \* Some areas of the Department may require a detailed justification of the placement of monitoring wells and the depth of monitoring well screened zones prior to granting installation approval.



W. Marshall Taylor Jr., Acting Director

*Promoting and protecting the health of the public and the environment*

April 8, 2015

RADFORD JENKINS  
GREENPOINTE LLC  
PO BOX 8028  
GREENVILLE SC 29604 8028

RE: Proposed Groundwater Monitoring Network Modifications (Hawkins to Oberly)  
Dated March 23, 2015  
Greenpointe Class 2 Landfill  
Solid Waste Permit #LF2-00001  
Anderson County

Dear Mr. Jenkins:

The referenced document has been reviewed with regard to the requirements of R.61-107.19 Part IV Subpart E of the South Carolina Solid Waste Management Regulations and the Facility's Solid Waste Permit.

The proposed abandonment of PZ-2 and PZ-9 is approved. Also, per the Author's discussion with the Facility's environmental consultant on March 30, 2015, well PZ-3 should be abandoned as well due to the earth moving activities that will take place in future Cell 3 in order to construct Cell 2. In addition to wells PZ-11 and PZ-12, an additional well should be installed along the border of Cell 2 and future Cell 3 due to the slow travel time of groundwater at the site. An amended plan to show these changes should be submitted before final approval can be provided.

If you have any questions regarding this, please feel free to contact me at (803) 898-1398 or oberlydj@dhec.sc.gov.

Sincerely,

David Oberly, II, Hydrogeologist  
Solid Waste Groundwater Section  
Division of Mining and Solid Waste Management  
Bureau of Land and Waste Management

cc: Adam Martin, Region 1 EQC (Anderson)  
Ty Hawkins, HRP Associates, Inc.  
Bureau File #21126



April 13, 2015

Mr. David Oberly II  
SCDHEC - BLWM  
2600 Bull Street  
Columbia, SC 29201

RE: REVISED PROPOSED GROUNDWATER MONITORING NETWORK MODIFICATIONS  
GREEN POINTE C&D LANDFILL (#LF2-00001)  
500 HAMLIN ROAD, EASLEY, ANDERSON COUNTY, SC  
(JOB#GRE4713.GW)

Dear Mr. Oberly:

As requested in SCDHEC's letter dated April 8, 2015, please find below the requested revisions to the Proposed Groundwater Modifications on behalf of Green Pointe Landfill. HRP Associates, Inc. (HRP) is seeking SCDHEC approval to alter and expand the current on-site groundwater monitoring network. Green Pointe Landfill is expanding the landfill footprint into Cell 2 (**Attachment 1**) in accordance with their previously approved permit. As such, the current groundwater network warrants modification to continue to monitor the landfill in accordance with the SCDHEC Regulation R.61-107.19, the Class 2 Landfill Permit #LF2-00001, and yet still allow the landfill to effectively conduct its operations. To modify the groundwater monitoring network, the following is planned:

- Abandonment of the three (3) existing groundwater monitoring wells. Two (2) within Cell 2 (PZ-2 and PZ-9) and one (1) within Cell 3 (PZ-3);
- Installation of two (2) new groundwater monitoring wells east of Cell 2 and Cell 3 (PZ-11 and PZ-12);
- Installation of one (1) new groundwater monitoring well (PZ-13) along the border of Cell 2 and Cell 3; and,
- The addition of three (3) existing groundwater monitoring wells (PZ-3, PZ-8, and PZ-5) to the landfill's groundwater monitoring network. Of note, these three wells are currently in-place, but not currently monitored as part of the landfill's groundwater monitoring network.

The expansion of the landfill footprint into Cell 2 requires the abandonment of the three (3) existing monitoring wells; two (2) within cell 2 (PZ-2 and PZ-9) and one (1) within Cell 3 (PZ-3). These monitoring wells will be abandoned by a licensed well driller in accordance with South Carolina Well Standards (R.61-71). Portland cement will be used to fill the total volume of each well using forced injection by tremie pipe from bottom to top. All aboveground well materials (stick-up vaults, casings and pads) will be removed and filled with native soil to the level of the surrounding ground surface. Approximately 70 feet of well footage will be abandoned.

Two (2) new down-gradient monitoring wells (PZ-11 and PZ-12) will be installed in strategic positions along the eastern landfill boundary to monitor groundwater quality in this area. PZ-11 will be installed down-gradient and southeast of Cell 1 and PZ-12 will be installed within 150 feet and down-gradient southeast of Cell 2. Additionally, a third new down-gradient monitoring well will be installed just down-gradient of Cell 2.

The proposed new monitoring wells will be installed by a licensed well driller in accordance with South Carolina Well Standards described in R.61-71 and South Carolina Solid Waste Management Regulations R.61-107.19. The wells will be 2-inch in diameter with 15-foot 10-slot screens. The exact depths and screened intervals will be dependent on Site lithology and depth to groundwater; however, based on existing wells, it is estimated that these monitoring wells will be installed to approximately 20 feet below ground surface. The SCDHEC Monitoring Well Applications are included as an attachment to this letter.

Two (2) additional existing groundwater wells (PZ-5 and PZ-8) will be added to the groundwater monitoring network. These two wells were installed as part of the initial feasibility assessment of landfill, but have not historically been monitored as part of the landfills groundwater monitoring network. PZ-8 is located 43 feet down-gradient of Cell 2. PZ-5 is located west of Cell 3 along the landfill's western boundary. Each of these wells is located down-gradient of active disposal unit and will be utilized to evaluate any potential impact to the underlying shallow aquifer.

As part of the utilization of PZ-5, this well will also be lowered to the current ground surface. Excavation in the area will require this well be cut to make accessible for sampling. After being cut, a new well pad will be installed and the TOC elevation will be surveyed to re-establish elevations to monitor site groundwater elevations.

Upon completion of the aforementioned modifications, the new landfill groundwater monitoring network will include the following seven (7) monitoring wells:

- PZ-1: up-gradient of the disposal unit and is considered a background well;
- PZ-10 and PZ-11: down-gradient of Cell 1; and,
- PZ-5, PZ-8, PZ-12, and PZ-13: down-gradient of Cell 2.

The groundwater new monitoring network will be sampled on a semi-annual basis in accordance with the SCDHEC approved October 19, 2009 Revised Groundwater Detection Monitoring Plan. Monitoring well locations are depicted in **Figure 1 (Attachment 1)**.

Mr. Oberly  
April 13, 2015  
Page 3

HRP will implement the aforementioned tasks immediately upon SCDHEC approval. If you have any questions or require additional information, please feel free to contact HRP at (864) 289-0311.

Sincerely,  
HRP Associates. Inc.

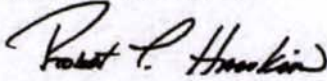

Robert T. Hawkins  
Project Manager

Attachments



# ATTACHMENT 1: PROPOSED GROUNDWATER MONITORING NETWORK





NO.	DATE	REVISIONS

DESIGNED BY:	RTH
DRAWN BY:	DML
REVIEWED BY:	RTH

ISSUE DATE:	03/23/2015
PROJECT NUMBER:	GRE4712.GW
SHEET SIZE:	11x17"

**SITE PLAN WITH  
 POTENTIOMETRIC GW  
 CONTOURS**  
 500 HAMLIN ROAD  
 GREENPONT  
 ANDERSON COUNTY, SOUTH CAROLINA

**FIGURE NO. 3**

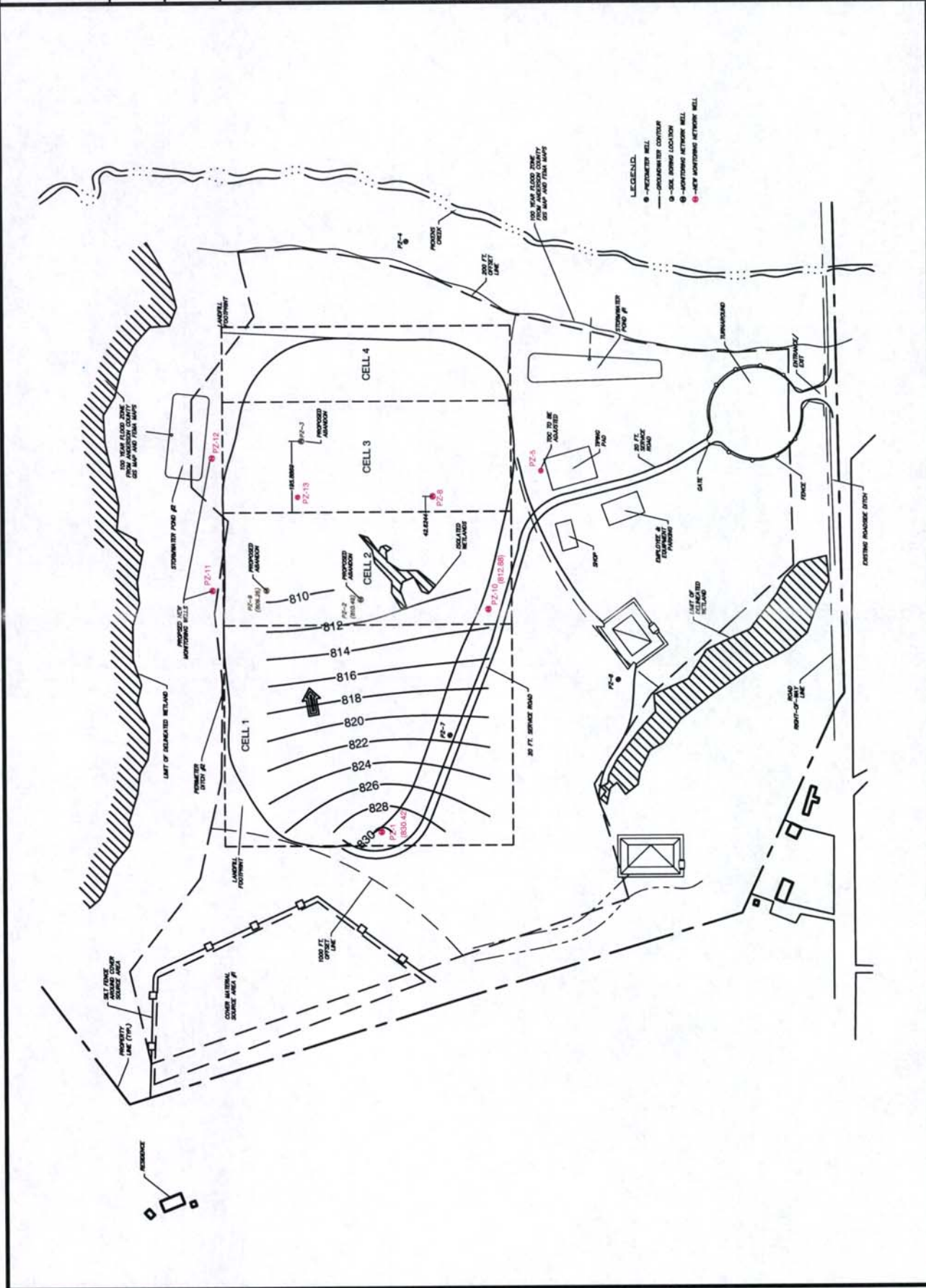

# ATTACHMENT 2:

## SCDHEC MONITORING WELL APPLICATION





# Monitoring Well Application

**1. Proposed Location of Monitoring Well(s):**

Street Address: **500 Hamlin Road**

City (including Zip): **Easley 29642**

County: **Anderson**

Please attach Scaled Map or Plat

**5. Intended Purpose of Well(s):**

Pre-Purchase

Investigation

**NOTE:** If this request is for an existing DHEC project, please enter the Program area and ID number below.

Program Area: **SCDHEC-BLWM**

Project or Site ID #: **#LF2-00001**

**6. Proposed number of monitoring wells: 3**

**2. Well Owner's Information:**

Name (Last then First): **Jenkins, Radford**

Company: **Green Pointe Landfill**

Complete Address: **P.O. Box 8028  
Greenville, SC 29604**

Telephone Number: **(864) 233-0100**

**7. Proposed parameters to be analyzed (check all that apply), please specify analytical method beside check box:**

VOCs

BTEX

MtBE

Naphthalene

PAHs

Metals

Nitrates

Base, Neutral & Acid Ex.

Pesticides/Herbicides

Phenols

Radionuclides

PCBs

Other (specify below)

**Metals: Ba, As, Cd, Cr, Pb, Hg, Se, Ag  
Chloride & Sulfate**

**3. Property Owner's Information:**

Check if same as Well Owner

Name (Last then First):

Company:

Address:

Telephone Number:

**8. Proposed construction details (complete and attach proposed monitoring well schematics):**

**4. Proposed Drilling Date: 05/01/2015**

**South Carolina Department of Health and Environmental Control (SCDHEC) summary of standards for monitoring well construction (per South Carolina Well Standards and Regulations R. 61-71)**

**Approval and License Requirements**

Prior Department approval is required for the installation or abandonment of all monitoring wells including direct push, geoprobe or other temporary type monitoring wells. The attached monitoring well approval document should be completed, submitted and approved prior to construction of any monitoring well. A monitoring well is any well used to obtain water samples for water quality analyses or to measure groundwater levels. There are no fees for approvals. All monitoring wells must be drilled by a driller that is registered in South Carolina with the Board of Certification of the Environmental Systems Operators. If any of the information on the application including the proposed drilling date, well construction details or well placement changes, the Department (i.e. project manager issuing the well approval) must be notified 24 hours prior to well construction.

**Location**

Due to the nature and purpose of a monitoring well, the depth and location requirements in respect to surface water bodies, potential contamination sources, etc., are variable, and shall be approved on a case by case basis by the Department.

**Construction and Material**

Casing should be of sufficient strength to withstand normal forces encountered during and after well installation and be composed of material so as to minimally affect water quality analyses. Casing should have a sufficient diameter to allow for efficient sample collection (i.e., to provide access for sampling equipment). The diameter of the drilled hole needs to be large enough on all sides (1.5 inches of annular space) to allow forced injection of grout through a tremie pipe. All monitoring wells should have a cement pad or aggregate reinforced concrete at the ground surface which extends at least six inches beyond the bore hole diameter and six inches below ground surface to prevent infiltration between the surface casing and the bore hole. All monitoring wells should be grouted from the top of the bentonite seal to the surface with a neat cement, high solids bentonite or neat cement, bentonite mixture approved by the Department. A hydrated bentonite seal with a minimum thickness of 12 inches is to be placed above the filter pack to prevent infiltration of grout if the well has a filter pack. The monitoring well intake or screen design should minimize the amount of formational materials entering the well. The gravel pack should be utilized opposite the well screen as appropriate so that parameters analyses will be minimally affected. All monitoring wells should have a locking cap or other security device to prevent damage and/or vandalism. Any monitoring well which is destroyed, rendered unusable or is abandoned should be reported to the Department and be properly abandoned, revitalized or replaced as appropriate or required by permit or regulation.

**Development**

Monitoring wells shall be properly developed. Development shall include the removal of formation cuttings and drilling fluids from the well bore hole. Development shall be complete when the well produces water typical of the aquifer being monitored.

## **Reporting Requirements**

A monitor well record form (1903) or equivalent to include the following should be completed and submitted to the Department within 30 days after completion of the monitoring wells:

Name and address of facility/owner;  
Surveyed or global positioning system location of monitor well(s) on a scaled map or plat;  
Driller and certification number;  
Date drilled;  
Driller's or Geologist's log;  
Total depth;  
Screened interval;  
Diameter and construction details;  
Depth to water table with date and time measured;  
Surveyed elevation of measuring point with respect to established benchmark;  
Monitoring well approval number issued by the Department.

Additionally, the groundwater and soil (if taken) analytical results should be submitted to the Department within 30 days of receipt from the laboratory.

## **Abandonment**

All monitoring wells shall be properly abandoned, when deemed appropriate by the Department. Any well that acts as a source of contamination shall be repaired or permanently abandoned immediately after receipt of notice from the Department. Abandonment shall be by forced injection of grout or pouring through a tremie pipe starting at the bottom of the well and proceeding to the surface in one continuous operation. The well shall be filled with either neat cement, bentonite-cement, or 20% high solids sodium bentonite grout, from the bottom of the well to the land surface.

- \* This summary of standards for monitoring well construction may not include a listing of all information necessary to obtain an approval to install monitoring wells. Final approval of monitoring well installation will be dependant upon the regulatory requirements for the Department program area for which the monitoring wells are to be installed.
- \* Some areas of the Department may require a detailed justification of the placement of monitoring wells and the depth of monitoring well screened zones prior to granting installation approval.

May 5, 2015



W. Marshall Taylor Jr., Acting Director

*Promoting and protecting the health of the public and the environment*

RADFORD JENKINS  
GREENPOINTE LLC  
PO BOX 8028  
GREENVILLE SC 29604 8028

RE: Monitoring Well Abandonment and Installation Request  
Dated April 13, 2015  
Greenpointe Class 2 Landfill  
Solid Waste Permit # LF2-00001  
Anderson County

Dear Mr. Jenkins:

The above referenced document has been reviewed with regard to the requirements of R.61-107.19 Part V Subpart E of the South Carolina Solid Waste Management Regulations and Solid Waste Permit # LF2-00001. The following comments were generated as a result of this review:

- 1) The request to install three new monitoring wells at the locations in the above-referenced correspondence is approved as submitted. Please see the attached groundwater monitoring well approval.
- 2) The Request to abandon the listed wells is approved.
- 3) The suggestion to add existing wells PZ-3, PZ-5, and PZ-8 to the routine monitoring system is approved.
- 4) Upon installation of the new wells, a revised Groundwater Monitoring Plan shall be submitted to account for these changes. Also, the Facility's Financial Assurance shall be amended to account for the additional wells being sampled. A revised cost estimate should be submitted for approval.

If you require any further information or have any questions or comments, please feel free to contact me at (803) 898-1398 or [oberlydj@dhec.sc.gov](mailto:oberlydj@dhec.sc.gov).

Sincerely,

David Oberly, II, Hydrogeologist  
Solid Waste Groundwater Section  
Division of Mining and Solid Waste Management  
Bureau of Land and Waste Management  
cc: Adam Martin, Upstate Region EQC Office (Anderson)  
Robert T. Hawkins, HRP Associates, Inc.  
Bureau File # 21126  
Encl: Monitoring Well approval MW-10134

## Monitoring Well Approval

**Approval is hereby granted to:** Radford Jenkins  
**Facility:** Greenpointe Class 2 Landfill  
**Solid Waste Permit #:** LF2-00001  
**County:** Anderson

This approval is for the installation of three (3) monitoring wells. The wells are to be installed in accordance with the locations as depicted in the April 13, 2015 correspondence. The wells are to be constructed within the surficial aquifer for the intended purpose of monitoring groundwater quality and/or water level at the referenced facility.

**Please note that R.61-71 requires the following:**

1. All wells shall be drilled, constructed, and abandoned by a South Carolina certified well driller per R.61-71.D.1.
2. All wells shall be properly developed per R.61-71.H.2.d. A Water Well Record Form (DHEC 1903) or other form provided or approved by the Department shall be completed for each well and submitted within 30 days after well completion or abandonment unless another schedule has been approved by the Department. The form should contain the "as-built" construction details and all other information required by R.61-71.H.1.f
3. All analytical data and water levels obtained from each monitoring well shall be submitted to the author of this approval within 30 days of receipt of laboratory results unless another schedule has been approved by the Department as required by R.61-71.H.1.d.
4. All monitoring wells shall be labeled as required by R.61-71.H.2.c.
5. If any of the information provided to the Department changes, David Oberly, II (803 898-1398 or OBERLYDJ@dhec.sc.gov) and the regional Solid Waste Consultant (Adam Martin, 864-260-5569) shall be notified at least twenty-four (24) hours prior to well construction as required by R.61-71.H.1.a.
6. All temporary monitoring wells shall be abandoned within 5 days of borehole completion using appropriate methods as required by R.61-71.H.4.c.

This approval is pursuant to the provisions of Section 44-55-40 of the 1976 South Carolina Code of Laws and R.61-71 of the South Carolina Well Standards and Regulations, dated April 26, 2002.

**Date of Issuance:** April 30, 2015

**Approval #:** MW-10134

  
David Oberly, II, Hydrogeologist  
Solid Waste Groundwater Section  
Division of Mining and Solid Waste Management  
Bureau of Land and Waste Management

# CIVIL DESIGN PLANS FOR THE CLASS II C&D GREENPOINTE LANDFILL ALONG HAMLIN ROAD LOCATED IN ANDERSON COUNTY, SOUTH CAROLINA

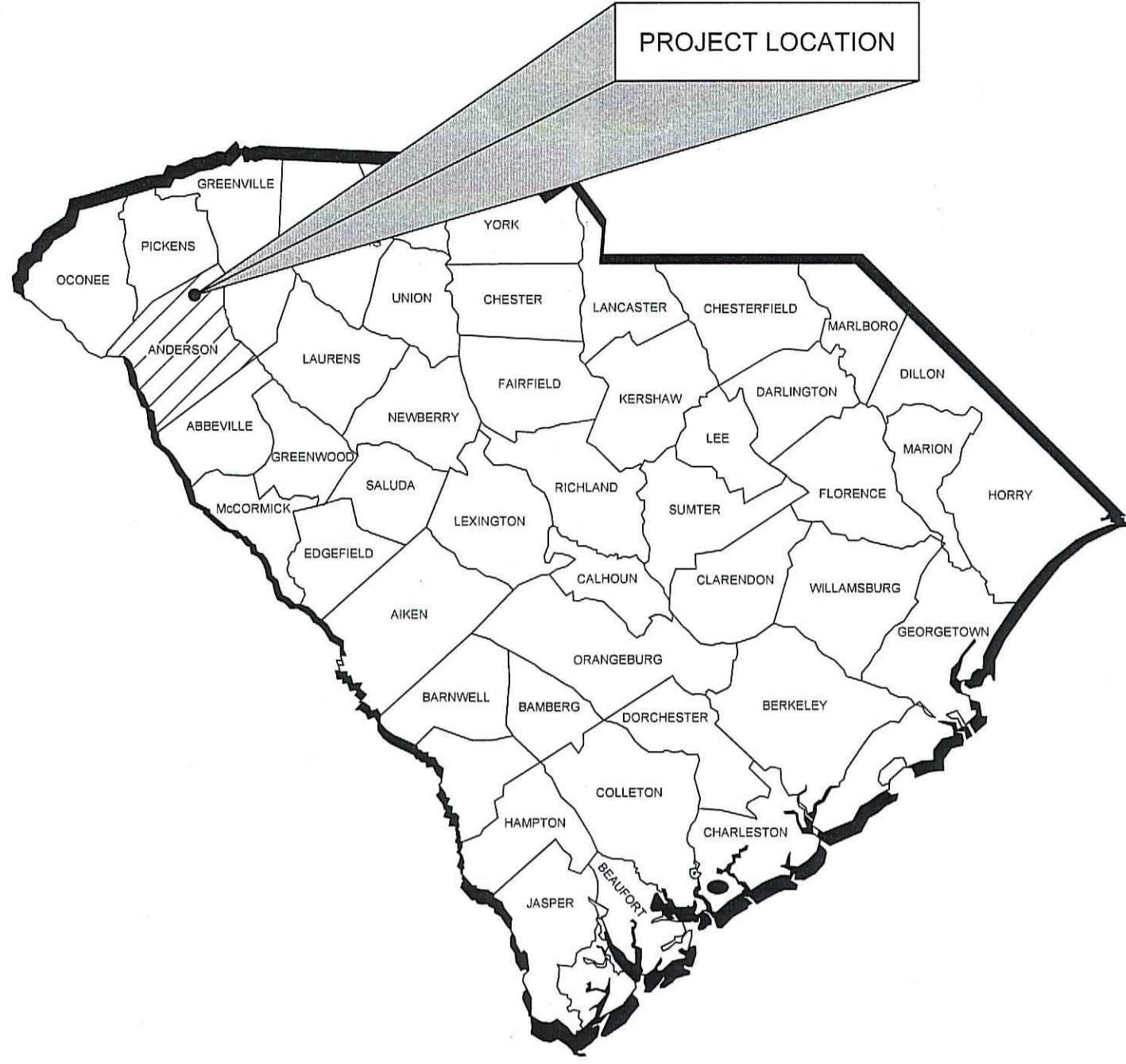

**CLIENT**  
WASTECO, INC.  
500 HAMLIN ROAD  
EASLEY, SOUTH CAROLINA 29642  
(864) 223-0100  
CONTACT: MR. RADFORD JENKINS, VP

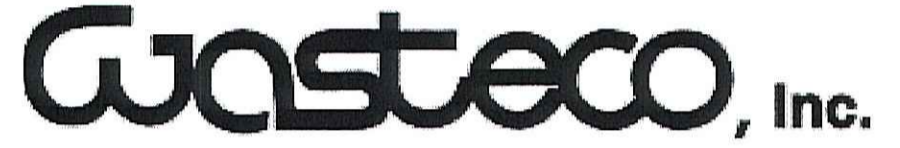

**CIVIL ENGINEER**  
ALLIANCE CONSULTING ENGINEERS, INC.  
POST OFFICE BOX 8147  
COLUMBIA, SOUTH CAROLINA 29202-8147  
(803) 779-2078  
CONTACT: RYAN T. OHMER, P.E.

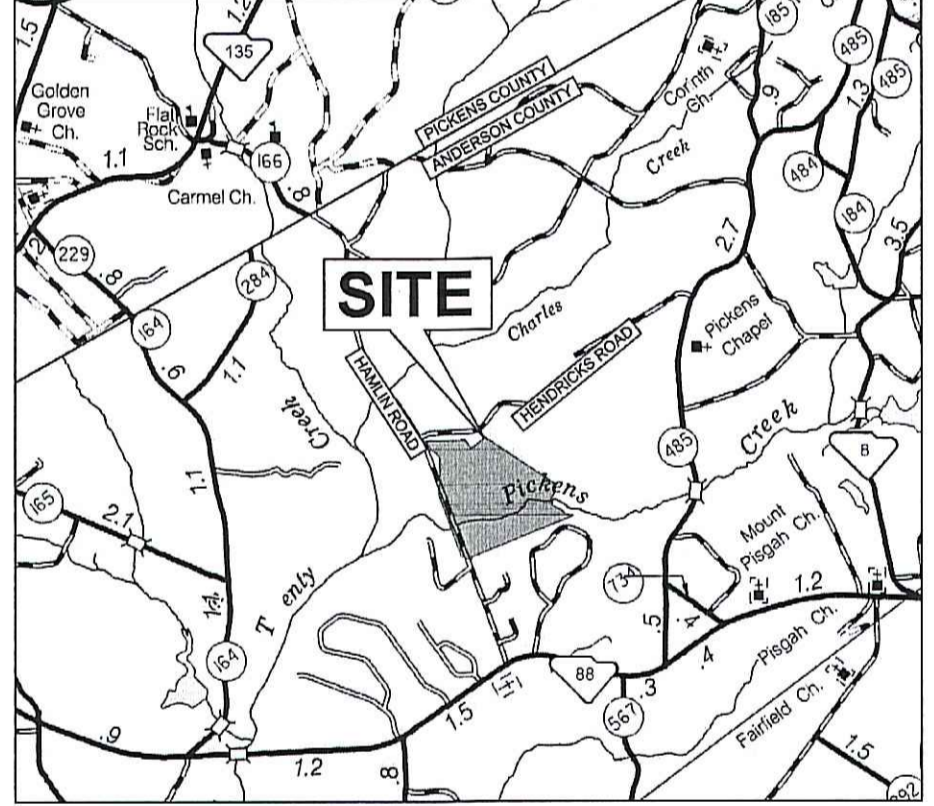

**SHEET INDEX**

<b>COVER SHEET</b>	
C-1.0	EXISTING CONDITIONS AND DEMOLITION PLAN
C-2.0	VICINITY PLAN
C-3.0	SITE PLAN
C-4.0	BASE ELEVATION GRADING AND STORM DRAINAGE PLAN - CELL 1
C-4.1	BASE ELEVATION GRADING AND STORM DRAINAGE PLAN - CELL 2
C-4.2	BASE ELEVATION GRADING AND STORM DRAINAGE PLAN - GRAVEL ROADWAY
C-4.3	FINAL ELEVATION - LIFT 1 GRADING AND STORM DRAINAGE PLAN - CELL 1
C-4.4	FINAL ELEVATION - LIFT 1 GRADING AND STORM DRAINAGE PLAN - CELL 2
C-4.5	FINAL ELEVATION - LIFT 2 GRADING AND STORM DRAINAGE PLAN - CELL 1
C-4.6	FINAL ELEVATION - LIFT 2 GRADING AND STORM DRAINAGE PLAN - CELL 2
C-4.7	FINAL ELEVATION - LIFT 3 GRADING AND STORM DRAINAGE PLAN - CELL 1
C-4.8	FINAL ELEVATION - LIFT 3 GRADING AND STORM DRAINAGE PLAN - CELL 2
C-4.9	FINAL ELEVATION - LIFT 4 GRADING AND STORM DRAINAGE PLAN - CELL 1
C-4.10	FINAL ELEVATION - LIFT 5 GRADING AND STORM DRAINAGE PLAN - CELL 1
C-5.0	BASE ELEVATION EROSION AND SEDIMENT CONTROL PLAN - CELL 1
C-5.1	BASE ELEVATION EROSION AND SEDIMENT CONTROL PLAN - CELL 2
C-5.2	BASE ELEVATION EROSION AND SEDIMENT CONTROL PLAN - GRAVEL ROADWAY
C-5.3	FINAL ELEVATION EROSION AND SEDIMENT CONTROL PLAN - CELL 1
C-5.4	FINAL ELEVATION EROSION AND SEDIMENT CONTROL PLAN - CELL 2
C-6.0	CROSS SECTION - CELL 1
C-6.1	CROSS SECTION - CELL 2
C-6.2	CROSS SECTION - FILL PROGRESSION
C-7.0 - C-7.1	EROSION AND SEDIMENT CONTROL DETAILS
C-8.0 - C-8.2	STORM DRAINAGE DETAILS

**LEGEND**

	EXISTING CONTOUR MAJOR		PROPOSED CONTOUR MAJOR
	EXISTING CONTOUR MINOR		PROPOSED CONTOUR MINOR
	EXISTING SPIGOT		PROPOSED STORM DRAIN LINE
	EXISTING POWER POLE		PROPOSED CATCH BASIN
	EXISTING OVERHEAD ELECTRICAL LINE		PROPOSED HEADWALL
	EXISTING UNDERGROUND TELECOMMUNICATIONS LINE		PROPOSED DEMOLITION
	EXISTING TREE LINE		PROPOSED EROSION CONTROL MATTING
	EXISTING WETLANDS		PROPOSED ROCK CHECK DAM
	EXISTING 100-YR FLOOD PLAIN		PROPOSED RIPRAP
	EXISTING CREEK		PROPOSED INLET PROTECTION
	EXISTING PIEZOTUBE		PROPOSED SILT FENCE
	EXISTING PIEZOMETER		PROPOSED FENCE OR JUTE BAFFLES
	BUFFER		PROPOSED GRAVEL
	LIMITS OF WASTE		



Know what's below.  
Call before you dig.

THE CONTRACTOR IS SPECIFICALLY CAUTIONED THAT THE LOCATION AND/OR ELEVATION OF EXISTING UTILITIES AS SHOWN ON THESE PLANS IS BASED ON RECORDS OF THE VARIOUS UTILITY COMPANIES AND, WHERE POSSIBLE, MEASUREMENTS TAKEN IN THE FIELD. THE INFORMATION IS NOT TO BE RELIED ON AS BEING EXACT OR COMPLETE. SC LAW REQUIRES THE CONTRACTOR TO CALL THE UTILITY PROTECTION CENTER AT LEAST 72 HOURS BEFORE ANY EXCAVATION TO REQUEST EXACT FIELD LOCATION OF UTILITIES. IT SHALL BE THE RESPONSIBILITY OF THE CONTRACTOR TO COORDINATE THE RELOCATION OF ALL THE UTILITIES WHICH CONFLICT WITH THE PROPOSED IMPROVEMENTS SHOWN ON THE PLANS.

**CERTIFICATION STATEMENTS**

I, HAVE PLACED MY SIGNATURE AND SEAL ON THE DESIGN DOCUMENTS SUBMITTED SIGNIFYING THAT I ACCEPT RESPONSIBILITY FOR THE DESIGN OF THE SYSTEM. FURTHER, I CERTIFY TO THE BEST OF MY KNOWLEDGE AND BELIEF THAT THE DESIGN IS CONSISTENT WITH THE REQUIREMENTS OF TITLE 48, CHAPTER 14 OF THE CODE OF LAWS OF SC, 1976 AS AMENDED, PURSUANT TO REGULATION 72-300 ET SEQ. (IF APPLICABLE), AND IN ACCORDANCE WITH THE TERMS AND CONDITIONS OF SCRI00000.

REVISION DATE	

APPROVALS	ENGINEER	RTO	DESIGNER	RTO	TECHNICAL	PRJ	CHECKED BY	GTF	APPROVED	RTO
-----------	----------	-----	----------	-----	-----------	-----	------------	-----	----------	-----

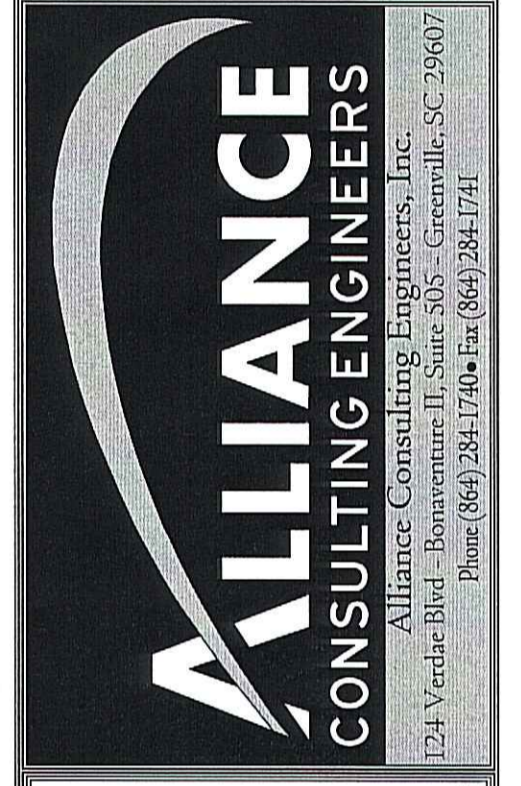
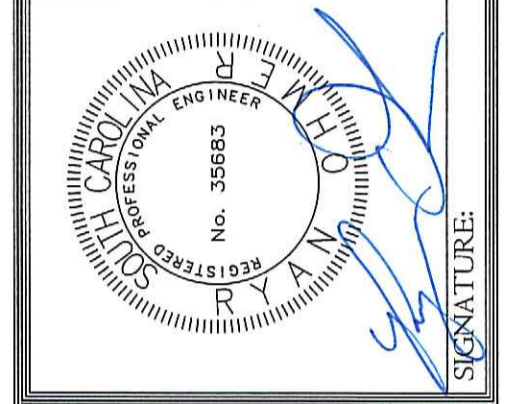
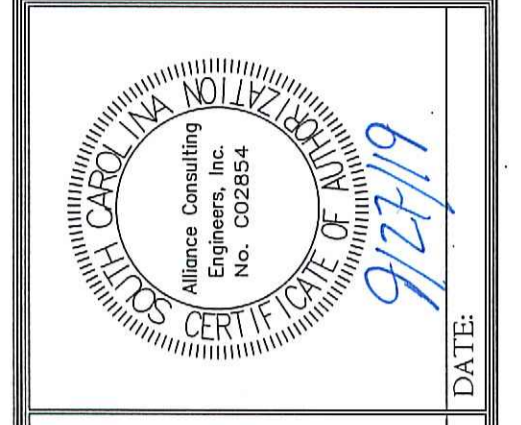

COVER SHEET

PROJECT  
CIVIL DESIGN PLANS FOR THE  
CLASS II C&D  
GREENPOINTE LANDFILL  
ALONG HAMLIN ROAD  
LOCATED IN  
ANDERSON COUNTY,  
SOUTH CAROLINA

FILE NAME:	E16227-PLANS
REFERENCE FILE:	E16227-BASE
PROJECT NO.:	I6227-0004

DWG NO. 01,1168-D21

THIS DOCUMENT IS THE SOLE PROPERTY OF ALLIANCE CONSULTING ENGINEERS, INC. IT IS NOT TO BE REPRODUCED, COPIED OR OTHERWISE EDITED WITH OUT THE AUTHORIZATION OF ALLIANCE CONSULTING ENGINEERS, INC. THIS DRAWING IS INTENDED SPECIFICALLY FOR THE PROJECT REFERENCED HEREIN AND IS NOT RESPONSIBLE TO ANY OTHER PROJECT.

SHEET

PROJECT

SCALE: AS SHOWN

DATE: JUNE 2019

SOUTH CAROLINA



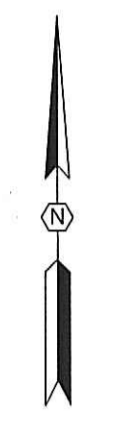
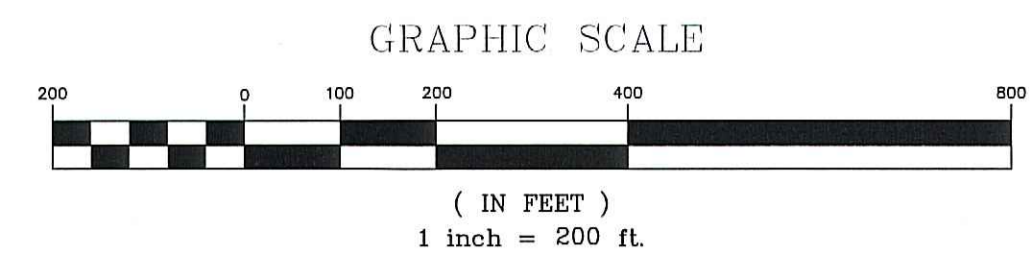

REVISION DATE	

APPROVALS:

ENGINEER	RTO	DESIGNER	RTO	TECHNICIAN	PSJ	CHECKED BY	GTF	APPROVED	KTO
----------	-----	----------	-----	------------	-----	------------	-----	----------	-----

DATE: 6/23/19

Signature block for the Engineer, including a circular seal for Alliance Consulting Engineers, Inc. No. 35683.

**ALLIANCE CONSULTING ENGINEERS**  
 Alliance Consulting Engineers, Inc.  
 124 Verdade Blvd. - Bonaville II, Suite 505 - Greenville, SC 29607  
 Phone (864) 284-1740 • Fax (864) 284-1741

PROJECT: CIVIL DESIGN PLANS FOR THE GREENPOINTE LANDFILL ALONG HAMLIN ROAD LOCATED IN ANDERSON COUNTY, SOUTH CAROLINA

DATE: JUNE 2019

SCALE: AS SHOWN

FILE NAME: E16227-PLANS

REFERENCE FILE: E16227-BASE

PROJECT NO. 16227-0004

SHEET C-10

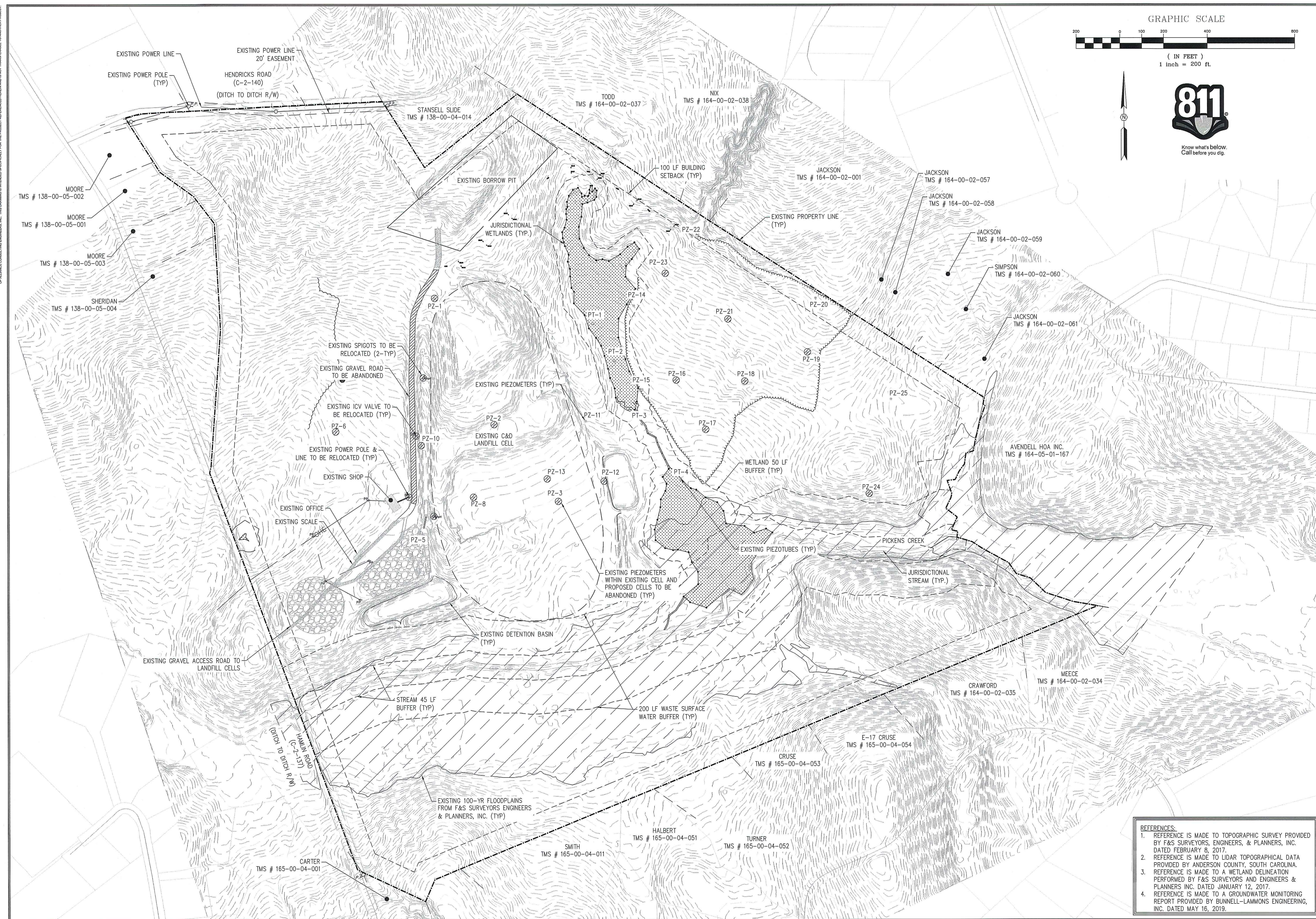

DWG NO. 01J168-D21



- REFERENCES:
- REFERENCE IS MADE TO TOPOGRAPHIC SURVEY PROVIDED BY F&S SURVEYORS, ENGINEERS, & PLANNERS, INC. DATED FEBRUARY 8, 2017.
  - REFERENCE IS MADE TO LIDAR TOPOGRAPHICAL DATA PROVIDED BY ANDERSON COUNTY, SOUTH CAROLINA.
  - REFERENCE IS MADE TO A WETLAND DELINEATION PERFORMED BY F&S SURVEYORS AND ENGINEERS & PLANNERS INC. DATED JANUARY 12, 2017.
  - REFERENCE IS MADE TO A GROUNDWATER MONITORING REPORT PROVIDED BY BUNNELL-LAMMONS ENGINEERING, INC. DATED MAY 16, 2019.







THIS DOCUMENT IS THE SOLE PROPERTY OF ALLIANCE CONSULTING ENGINEERS, INC. IT IS NOT TO BE REPRODUCED, COPIED OR OTHERWISE DISTRIBUTED WITHOUT THE WRITTEN AUTHORIZATION OF ALLIANCE CONSULTING ENGINEERS, INC. THIS DOCUMENT IS PROVIDED SPECIFICALLY FOR THE PROJECT AND SITE IDENTIFIED HEREIN. IT IS NOT TO BE REPRODUCED OR USED FOR ANY OTHER PROJECT OR SITE.

**ZONING CLASSIFICATIONS:**

S-1  S-1  
R-20  R-20  
NONE  NONE

NOTE: ALL OTHER PARCELS ARE CLASSIFIED R-A



**LEGEND**

1 MILE PROPERTY LINE OFFSET   
1000 LF RESIDENTIAL LINE OFFSET   
UNPAVED ROAD   
BUILDINGS   
JURISDICTIONAL STREAM   
100-YEAR FLOOD PLAIN   
JURISDICTIONAL WETLANDS 

GRAPHIC SCALE

800 0 400 800 1,600 3,200

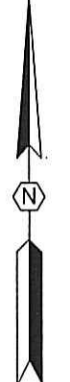
( IN FEET )  
1 inch = 800 ft.

REVISION DATE	

APPROVALS

ENGINEER: RTO  
DESIGNER: RTO  
TECHNICIAN: PRJ  
CHECKED BY: GTF  
APPROVED: RTO

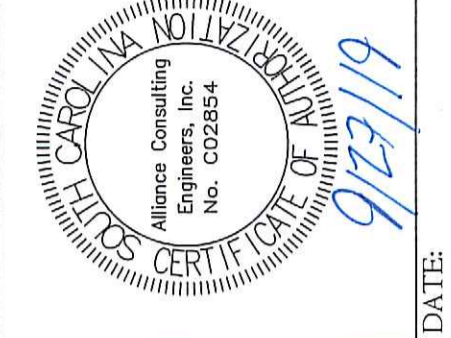

DATE: 9/23/19

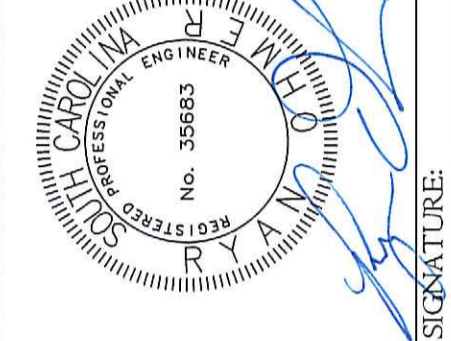

SIGNATURE: R. A. V.

**ALLIANCE CONSULTING ENGINEERS**

Alliance Consulting Engineers, Inc.  
124 Verdine Blvd - Bonaventure II, Suite 505 - Greenville, SC 29607  
Phone (864) 284-1740 Fax (864) 284-1741

VICINITY PLAN

SCALE: AS SHOWN

DATE: JUNE 2019

PROJECT

CIVIL DESIGN PLANS FOR THE CLASS II C&D GREENPOINTE LANDFILL ALONG HAMLIN ROAD LOCATED IN ANDERSON COUNTY, SOUTH CAROLINA

ANDERSON COUNTY SOUTH CAROLINA

FILE NAME: E16227-PLANS  
REFERENCE FILE: E16227-BASE  
PROJECT NO. 16227-0004  
DWG NO. 01.1168-D21

SHEET C-2.0

- REFERENCES:**
- REFERENCE IS MADE TO TOPOGRAPHIC SURVEY PROVIDED BY F&S SURVEYORS, ENGINEERS, & PLANNERS, INC. DATED FEBRUARY 8, 2017.
  - REFERENCE IS MADE TO LIDAR TOPOGRAPHICAL DATA PROVIDED BY ANDERSON COUNTY, SOUTH CAROLINA.
  - REFERENCE IS MADE TO A WETLAND DELINEATION PERFORMED BY F&S SURVEYORS AND ENGINEERS & PLANNERS INC. DATED JANUARY 12, 2017.
  - REFERENCE IS MADE TO A GROUNDWATER MONITORING REPORT PROVIDED BY BUNNELL-LAMMONS ENGINEERING, INC. DATED MAY 16, 2019.

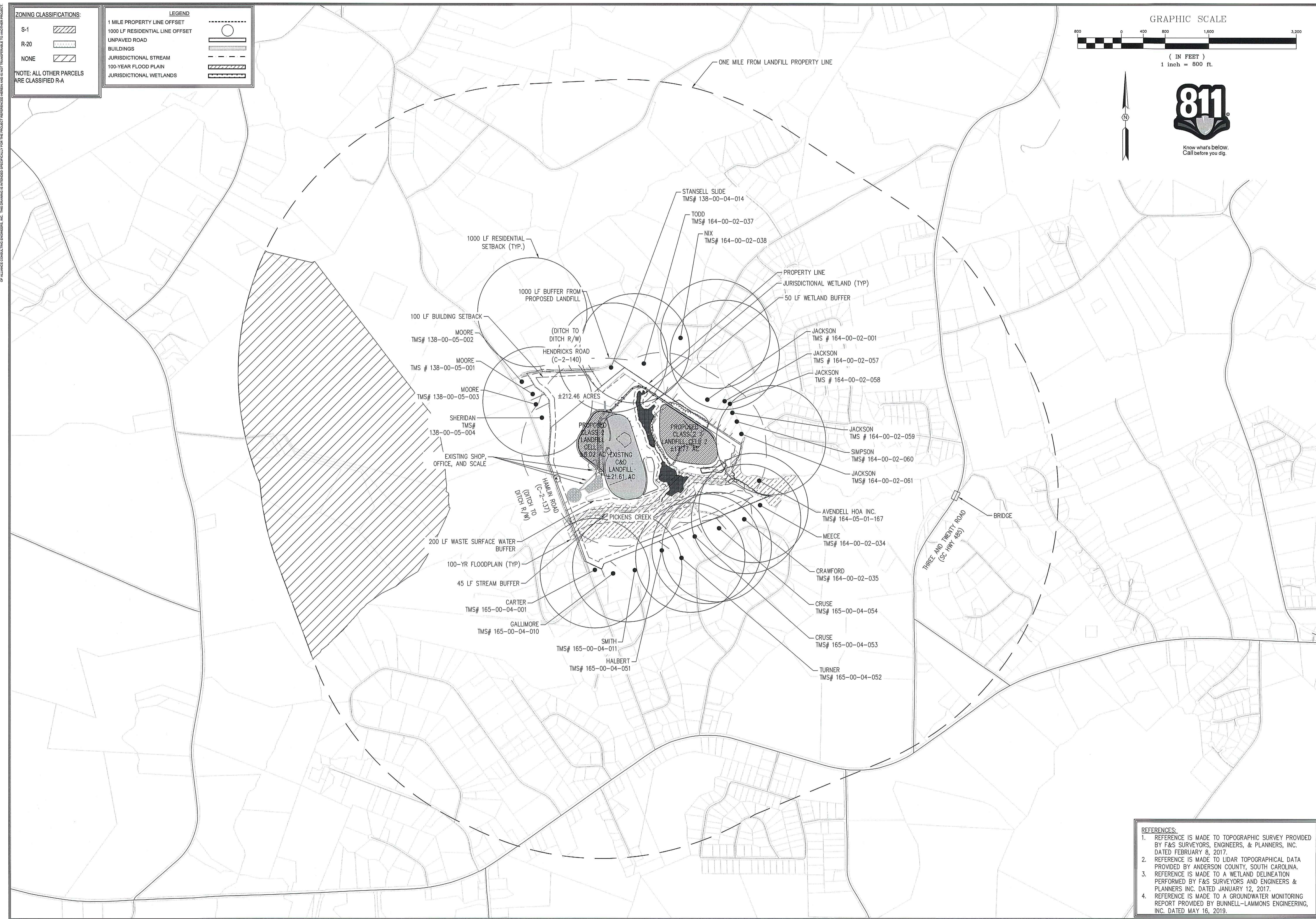

THIS DOCUMENT IS THE SOLE PROPERTY OF ALLIANCE CONSULTING ENGINEERS, INC. IT IS NOT TO BE REPRODUCED, COPIED OR OTHERWISE EDITED WITHOUT THE AUTHORIZATION OF ALLIANCE CONSULTING ENGINEERS, INC. THIS DRAWING IS INTENDED SPECIFICALLY FOR THE PROJECT REFERENCED HEREIN AND IS NOT TRANSFERABLE TO ANOTHER PROJECT.

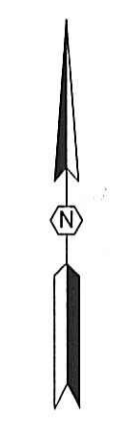
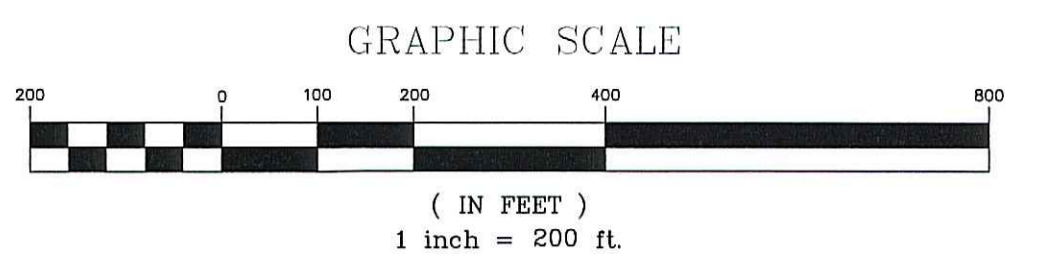
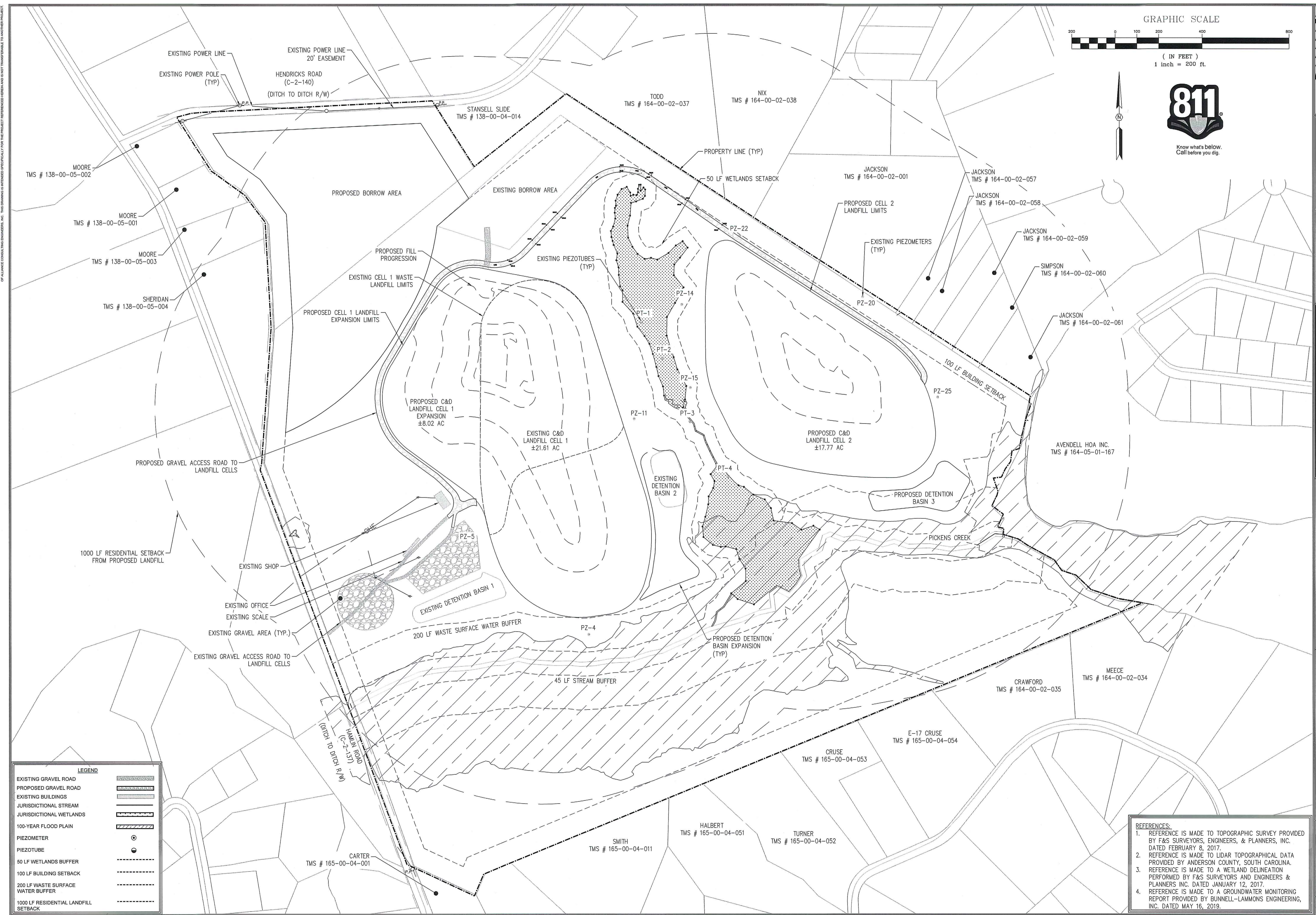

REVISION DATE	

APPROVALS

ENGINEER	RTO	DESIGNER	RTO	TECHNICAL	PRJ	CHECKED BY	GTF	APPROVED	RTO
----------	-----	----------	-----	-----------	-----	------------	-----	----------	-----

ALLIANCE CONSULTING ENGINEERS, INC.  
Engineers, Inc. No. 020254  
SOUTH CAROLINA REGISTERED PROFESSIONAL ENGINEERS  
DATE: 9/22/19

REGISTERED PROFESSIONAL ENGINEER  
No. 35883  
RES. 10/10/10  
SIGNATURE: [Signature]

**ALLIANCE CONSULTING ENGINEERS**  
Alliance Consulting Engineers, Inc.  
124 Verdac Blvd., Bonaventure II, Suite 505 - Greenville, SC 29607  
Phone (864) 284-1748 Fax (864) 284-1741

SITE PLAN

SHEET

DATE: JUNE 2019

SCALE: AS SHOWN

PROJECT: CIVIL DESIGN PLANS FOR THE CLASS II C&D GREENPOINTE LANDFILL ALONG HAMLIN ROAD LOCATED IN ANDERSON COUNTY, SOUTH CAROLINA

**LEGEND**

EXISTING GRAVEL ROAD	[Symbol]
PROPOSED GRAVEL ROAD	[Symbol]
EXISTING BUILDINGS	[Symbol]
JURISDICTIONAL STREAM	[Symbol]
JURISDICTIONAL WETLANDS	[Symbol]
100-YEAR FLOOD PLAIN	[Symbol]
PIEZOMETER	[Symbol]
PIEZOTUBE	[Symbol]
50 LF WETLANDS BUFFER	[Symbol]
100 LF BUILDING SETBACK	[Symbol]
200 LF WASTE SURFACE WATER BUFFER	[Symbol]
1000 LF RESIDENTIAL LANDFILL SETBACK	[Symbol]

- REFERENCES:**
1. REFERENCE IS MADE TO TOPOGRAPHIC SURVEY PROVIDED BY F&S SURVEYORS, ENGINEERS, & PLANNERS, INC. DATED FEBRUARY 8, 2017.
  2. REFERENCE IS MADE TO LIDAR TOPOGRAPHICAL DATA PROVIDED BY ANDERSON COUNTY, SOUTH CAROLINA.
  3. REFERENCE IS MADE TO A WETLAND DELINEATION PERFORMED BY F&S SURVEYORS AND ENGINEERS & PLANNERS INC. DATED JANUARY 12, 2017.
  4. REFERENCE IS MADE TO A GROUNDWATER MONITORING REPORT PROVIDED BY BUNNELL-LAMMONS ENGINEERING, INC. DATED MAY 16, 2019.

FILE NAME:	E16227-PLANS	SHEET <b>C-3.0</b>
REFERENCE FILE:	E16227-BASE	
PROJECT NO.:	16227-0004	
DWG NO. 01,1168-D21		

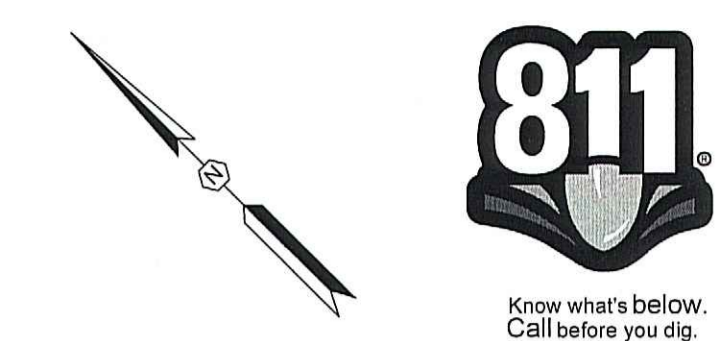
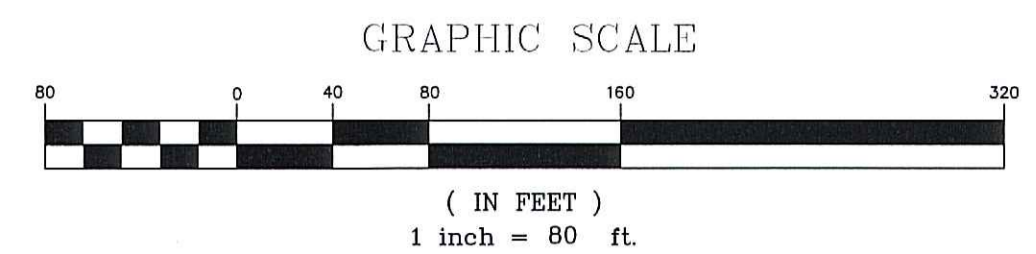

REVISION DATE	

APPROVALS

ENGINEER	RTO	DESIGNER	RTO	TECHNICIAN	PSJ	CHECKED BY	GTF	APPROVED	RTO
----------	-----	----------	-----	------------	-----	------------	-----	----------	-----

DATE: 02/14/19

REGISTERED PROFESSIONAL ENGINEER

SCOTT CAROLINA ENGINEERS, INC.

No. 35683

SIGNATURE: [Signature]

**ALLIANCE CONSULTING ENGINEERS**

Alliance Consulting Engineers, Inc.  
124 Verdade Blvd., Bonaventure II, Suite 205 - Greenville, SC 29607  
Phone: (864) 294-1746 Fax: (864) 294-1741

PROJECT: CIVIL DESIGN PLANS FOR THE CLASS II C&D GREENPOINTE LANDFILL ALONG HAMLIN ROAD LOCATED IN ANDERSON COUNTY, SOUTH CAROLINA

SCALE: AS SHOWN

DATE: JUNE 2019

FILE NAME: E16227-PLANS

REFERENCE FILE: E16227-BASE

PROJECT NO.: 16227-0004

SHEET: C-4.0

DWG NO. 01.1168-D21



LEGEND

EXISTING GRAVEL ROAD	[Symbol]
PROPOSED GRAVEL ROAD	[Symbol]
EXISTING BUILDINGS	[Symbol]
JURISDICTIONAL STREAM	[Symbol]
JURISDICTIONAL WETLANDS	[Symbol]
100-YEAR FLOOD PLAIN	[Symbol]
PIEZOMETER	[Symbol]
PIEZOTUBE	[Symbol]
50 LF WETLANDS BUFFER	[Symbol]
100 LF BUILDING SETBACK	[Symbol]
200 LF WASTE SURFACE WATER BUFFER	[Symbol]
LIMITS OF WASTE	[Symbol]

NOTE: TOPS OF LIFTS ARE TO HAVE SLOPES BETWEEN THREE (3) TO FIVE (5) PERCENT.

- REFERENCES:
- REFERENCE IS MADE TO TOPOGRAPHIC SURVEY PROVIDED BY F&S SURVEYORS, ENGINEERS, & PLANNERS, INC. DATED FEBRUARY 8, 2017.
  - REFERENCE IS MADE TO LIDAR TOPOGRAPHICAL DATA PROVIDED BY ANDERSON COUNTY, SOUTH CAROLINA.
  - REFERENCE IS MADE TO A WETLAND DELINEATION PERFORMED BY F&S SURVEYORS AND ENGINEERS & PLANNERS INC. DATED JANUARY 12, 2017.
  - REFERENCE IS MADE TO A GROUNDWATER MONITORING REPORT PROVIDED BY BUNNELL-LAMMONS ENGINEERING, INC. DATED MAY 16, 2019.

THIS DOCUMENT IS THE SOLE PROPERTY OF ALLIANCE CONSULTING ENGINEERS, INC. IT IS NOT TO BE REPRODUCED, COPIED OR OTHERWISE EDITED WITH OUT THE AUTHORIZATION OF ALLIANCE CONSULTING ENGINEERS, INC. THE DRAWING IS INTENDED SPECIFICALLY FOR THE PROJECT PERFORMED HEREIN AND IS NOT TO BE REPRODUCED TO ANY OTHER PROJECT.

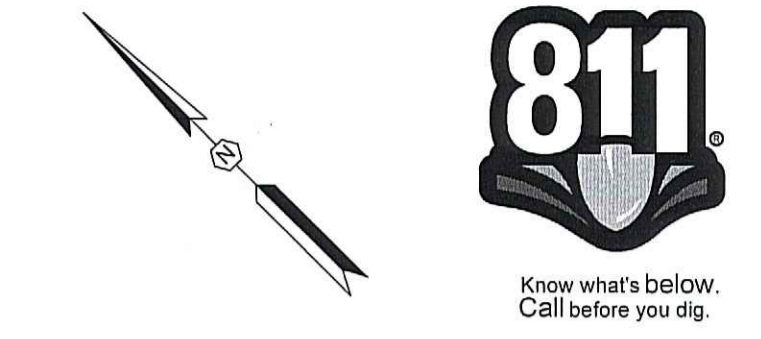
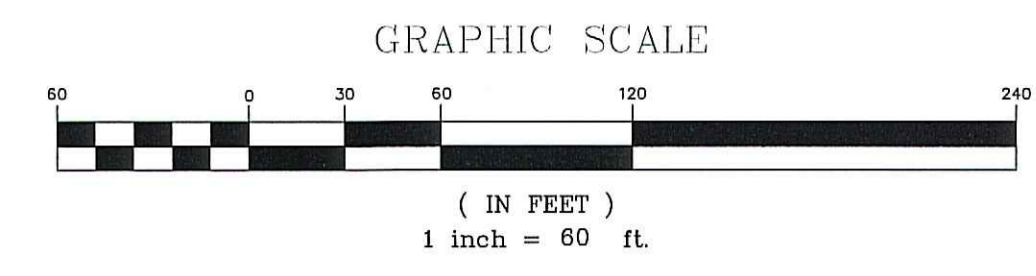

APPROVALS	
ENGINEER	RTO
DESIGNER	RTO
TECHNICIAN	PRJ
CHECKED BY	GTF
APPROVED	RTO

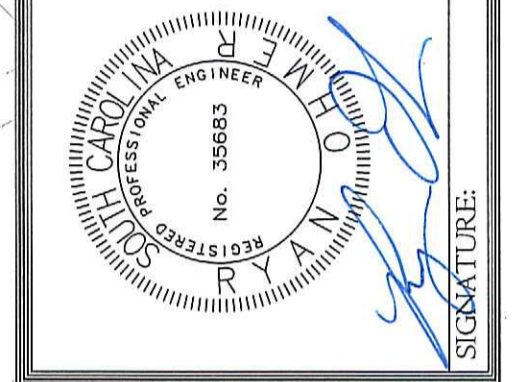
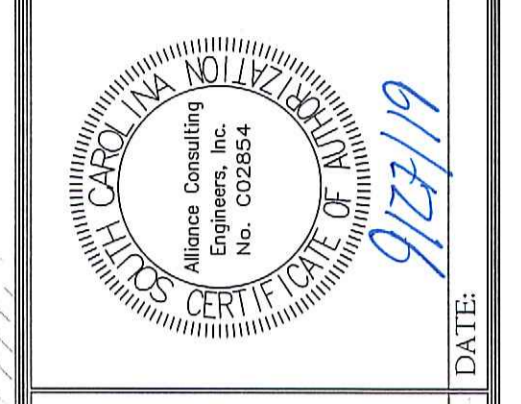

**ALLIANCE CONSULTING ENGINEERS**  
 Alliance Consulting Engineers, Inc.  
 124 Verde Blvd - Bonaville II, Suite 305 - Greenville, SC 29607  
 Phone (864) 284-1740 Fax (864) 284-1741

PROJECT: CIVIL DESIGN PLANS FOR THE CLASS II C&D GREENPOINTE LANDFILL ALONG HAMLIN ROAD LOCATED IN ANDERSON COUNTY, SOUTH CAROLINA  
 SHEET: BASE ELEVATION GRADING AND STORM DRAINAGE PLAN - CELL 2  
 DATE: JUNE 2019  
 SCALE: AS SHOWN

PROJECT: CIVIL DESIGN PLANS FOR THE CLASS II C&D GREENPOINTE LANDFILL ALONG HAMLIN ROAD LOCATED IN ANDERSON COUNTY, SOUTH CAROLINA  
 SHEET: BASE ELEVATION GRADING AND STORM DRAINAGE PLAN - CELL 2  
 DATE: JUNE 2019  
 SCALE: AS SHOWN

FILE NAME: E16227-PLANS  
 REFERENCE FILE: E16227-BASE  
 PROJECT NO. 16227-0004  
 DWG NO. 01.1168-D21

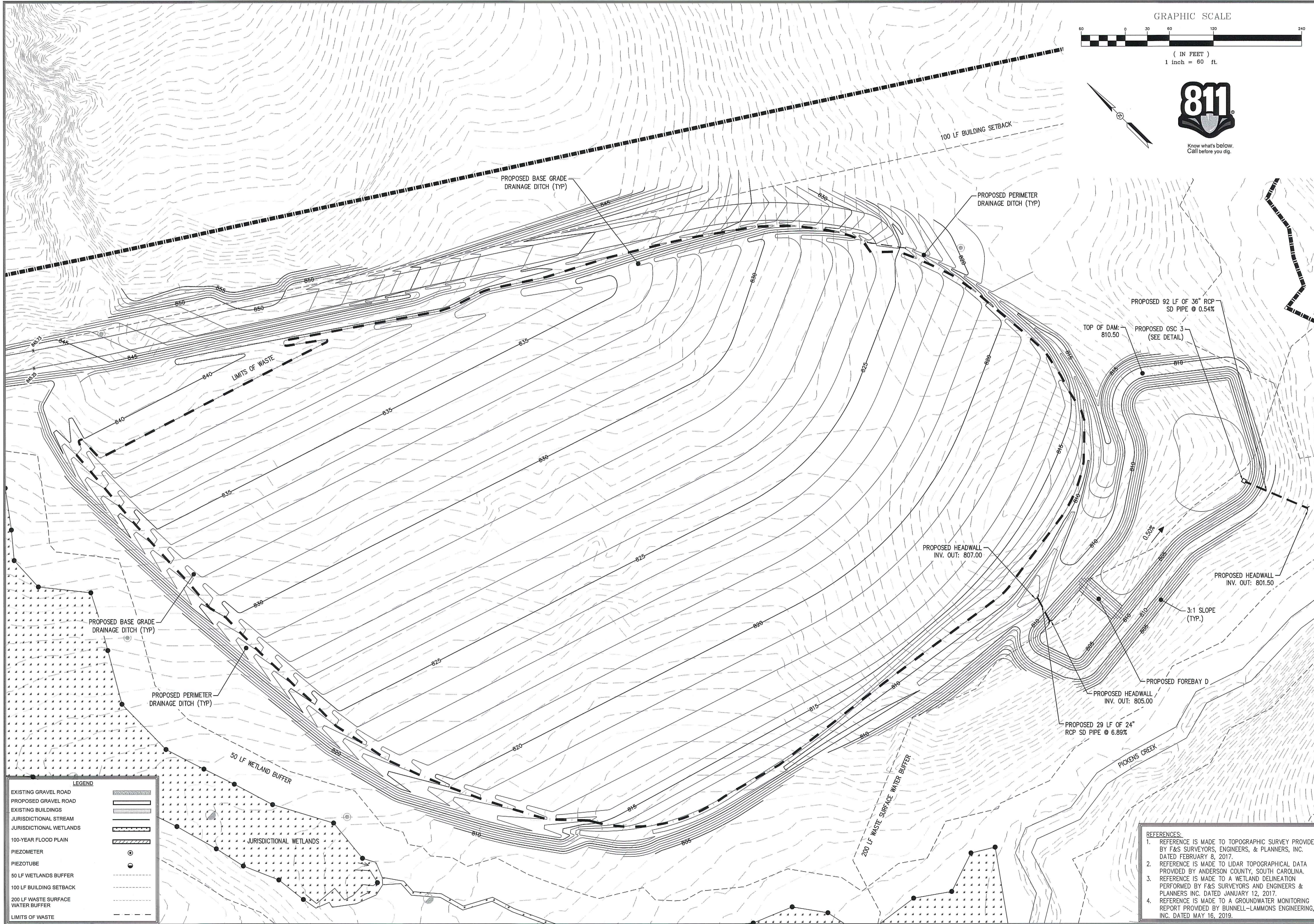

**LEGEND**

EXISTING GRAVEL ROAD	
PROPOSED GRAVEL ROAD	
EXISTING BUILDINGS	
JURISDICTIONAL STREAM	
JURISDICTIONAL WETLANDS	
100-YEAR FLOOD PLAIN	
PIEZOMETER	
PIEZOTUBE	
50 LF WETLANDS BUFFER	
100 LF BUILDING SETBACK	
200 LF WASTE SURFACE WATER BUFFER	
LIMITS OF WASTE	

- REFERENCES:**
- REFERENCE IS MADE TO TOPOGRAPHIC SURVEY PROVIDED BY F&S SURVEYORS, ENGINEERS, & PLANNERS, INC. DATED FEBRUARY 8, 2017.
  - REFERENCE IS MADE TO LIDAR TOPOGRAPHICAL DATA PROVIDED BY ANDERSON COUNTY, SOUTH CAROLINA. REFERENCE IS MADE TO A WETLAND DELINEATION PERFORMED BY F&S SURVEYORS AND ENGINEERS & PLANNERS INC. DATED JANUARY 12, 2017.
  - REFERENCE IS MADE TO A GROUNDWATER MONITORING REPORT PROVIDED BY BUNNELL-LAMMONS ENGINEERING, INC. DATED MAY 16, 2019.

THIS DOCUMENT IS THE SOLE PROPERTY OF ALLIANCE CONSULTING ENGINEERS, INC. IT IS NOT TO BE REPRODUCED, COPIED OR OTHERWISE DISTRIBUTED WITHOUT THE AUTHORIZATION OF ALLIANCE CONSULTING ENGINEERS, INC. THIS DRAWING IS INTENDED SPECIFICALLY FOR THE PROJECT REFERENCED HEREIN AND IS NOT TRANSFERABLE TO ANOTHER PROJECT.

GRAPHIC SCALE

( IN FEET )  
1 inch = 40 ft.

REVISION DATE	

APPROVALS	ENGINEER	RTO	DESIGNER	RTO	TECHNICIAN	PRJ	CHECKED BY	GTF	APPROVED	RTO
-----------	----------	-----	----------	-----	------------	-----	------------	-----	----------	-----

DATE: 9/27/19

SIGNATURE: Ryan J. Taylor

**ALLIANCE CONSULTING ENGINEERS, INC.**  
Alliance Consulting Engineers, Inc.  
124 Verdade Blvd - Bonaventure II, Suite 505 - Greenville, SC 29607  
Phone: (864) 284-1740 Fax: (864) 284-1741

SCALE: AS SHOWN

DATE: JUNE 2019

SHEET

PROJECT

BASE ELEVATION GRADING AND STORM DRAINAGE PLAN - GRAVEL ROAD

CIVIL DESIGN PLANS FOR THE CLASS II C&D GREENPOINTE LANDFILL ALONG HAMLIN ROAD LOCATED IN ANDERSON COUNTY, SOUTH CAROLINA

ANDERSON COUNTY SOUTH CAROLINA

FILE NAME: E16227-PLANS  
REFERENCE FILE: E16227-BASE  
PROJECT NO.: 16227-0004

SHEET C-42

DWG NO. 01.1168-D21

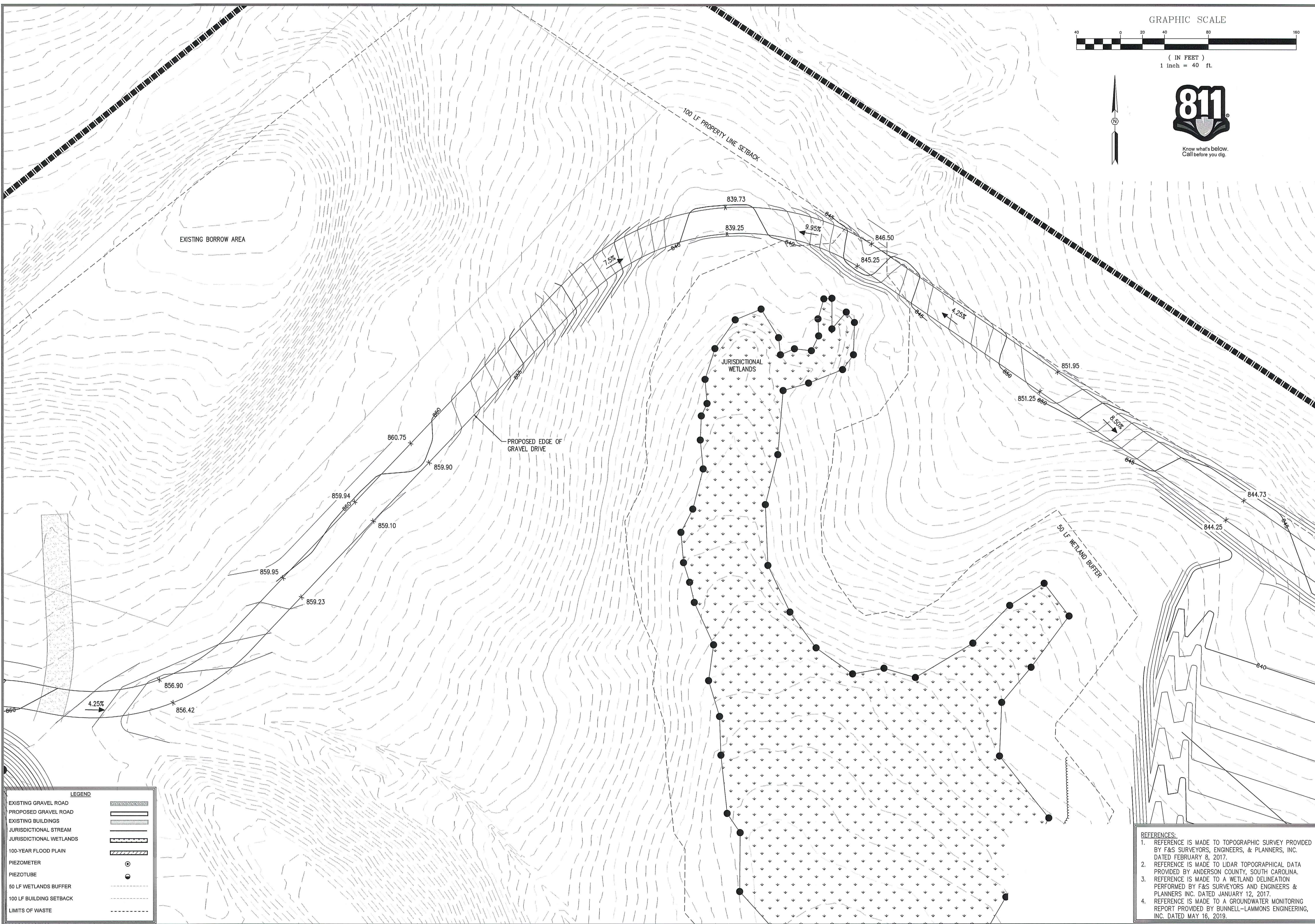

LEGEND	
EXISTING GRAVEL ROAD	
PROPOSED GRAVEL ROAD	
EXISTING BUILDINGS	
JURISDICTIONAL STREAM	
JURISDICTIONAL WETLANDS	
100-YEAR FLOOD PLAIN	
PIEZOMETER	
PIEZOTUBE	
50 LF WETLANDS BUFFER	
100 LF BUILDING SETBACK	
LIMITS OF WASTE	

THIS DOCUMENT IS THE SOLE PROPERTY OF ALLIANCE CONSULTING ENGINEERS, INC. IT IS NOT TO BE REPRODUCED, COPIED OR OTHERWISE USED WITHOUT THE AUTHORIZATION OF ALLIANCE CONSULTING ENGINEERS, INC. THIS DRAWING IS INTENDED SPECIFICALLY FOR THE PROJECT REFERENCED HEREIN AND IS NOT TRANSFERABLE TO ANY OTHER PROJECT.

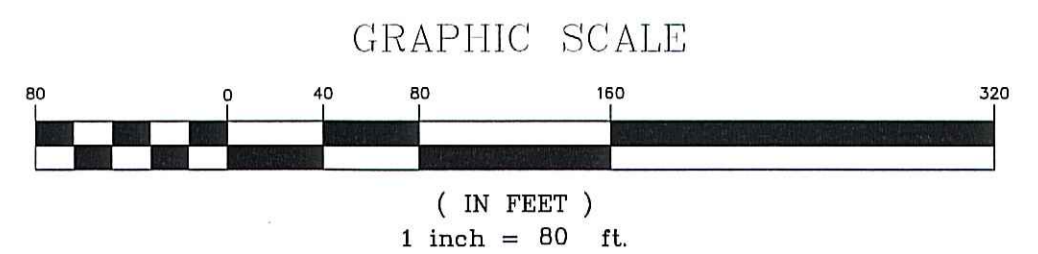

REVISION DATE	

APPROVALS:

ENGINEER	RTO
DESIGNER	RTO
TECHNICIAN	PN
CHECKED BY	GTF
APPROVED	RTO

ALLIANCE CONSULTING ENGINEERS, INC.  
 License No. C00854  
 PROFESSIONAL ENGINEER  
 DATE: 9/27/19

REGISTERED PROFESSIONAL ENGINEER  
 License No. 35683  
 DATE: 9/27/19

**ALLIANCE CONSULTING ENGINEERS**  
 Alliance Consulting Engineers, Inc.  
 124 Verdine Blvd., Suite 305, Anderson, SC 29607  
 Phone: (864) 384-1740 • Fax: (864) 384-1741

PROJECT: CIVIL DESIGN PLANS FOR THE CLASS II C&D GREENPOINTE LANDFILL ALONG HAMLIN ROAD LOCATED IN ANDERSON COUNTY, SOUTH CAROLINA  
 SHEET: FINAL ELEVATION - LIFT 1 GRADING AND STORM DRAINAGE PLAN - CELL 1  
 SCALE: AS SHOWN  
 DATE: JUNE 2019

FILE NAME: E16227-PLANS  
 REFERENCE FILE: E16227-BASE  
 PROJECT NO: 16227-0004  
 DWG NO. 01,1168-D21

LEGEND	
EXISTING GRAVEL ROAD	
PROPOSED GRAVEL ROAD	
EXISTING BUILDINGS	
JURISDICTIONAL STREAM	
JURISDICTIONAL WETLANDS	
100-YEAR FLOOD PLAIN	
PIEZOMETER	
PIEZOTUBE	
50 LF WETLANDS BUFFER	
100 LF BUILDING SETBACK	
200 LF WASTE SURFACE WATER BUFFER	
LIMITS OF WASTE	

NOTE: TOPS OF LIFTS ARE TO HAVE SLOPES BETWEEN THREE (3) TO FIVE (5) PERCENT.

REFERENCES:

- REFERENCE IS MADE TO TOPOGRAPHIC SURVEY PROVIDED BY F&S SURVEYORS, ENGINEERS, & PLANNERS, INC. DATED FEBRUARY 8, 2017.
- REFERENCE IS MADE TO LIDAR TOPOGRAPHICAL DATA PROVIDED BY ANDERSON COUNTY, SOUTH CAROLINA.
- REFERENCE IS MADE TO A WETLAND DELINEATION PERFORMED BY F&S SURVEYORS AND ENGINEERS & PLANNERS INC. DATED JANUARY 12, 2017.
- REFERENCE IS MADE TO A GROUNDWATER MONITORING REPORT PROVIDED BY BUNNELL-LAMMONS ENGINEERING, INC. DATED MAY 16, 2019.

THIS DOCUMENT IS THE SOLE PROPERTY OF ALLIANCE CONSULTING ENGINEERS, INC. IT IS NOT TO BE REPRODUCED, COPIED OR OTHERWISE DISTRIBUTED WITHOUT THE AUTHORIZATION OF ALLIANCE CONSULTING ENGINEERS, INC. THIS DRAWING IS INTENDED SPECIFICALLY FOR THE PROJECT REFERENCED HEREIN AND IS NOT TRANSFERABLE TO ANY OTHER PROJECT.

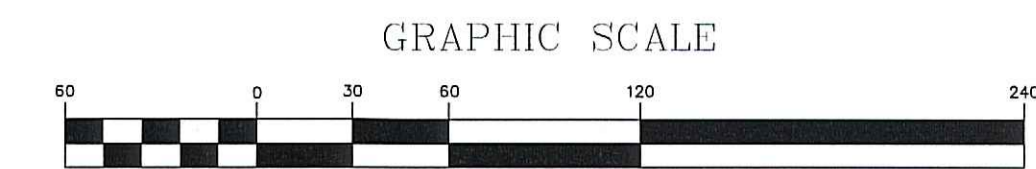

GRAPHIC SCALE  
( IN FEET )  
1 inch = 60 ft.

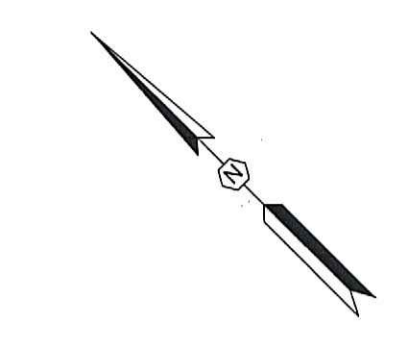

Know what's below.  
Call before you dig.

REVISION DATE	

APPROVALS

ENGINEER	RTO	DESIGNER	RTO	TECHNICIAN	PRJ	CHECKED BY	GTF	APPROVED	RTO
----------	-----	----------	-----	------------	-----	------------	-----	----------	-----

ALLIANCE CONSULTING ENGINEERS, INC. No. 002854  
SOUTH CAROLINA PROFESSIONAL ENGINEERING CERTIFICATE OF QUALITY  
DATE: 9/27/19

PROFESSIONAL ENGINEER  
No. 35683  
R. S. ANAN  
SIGNATURE: [Signature]

**ALLIANCE CONSULTING ENGINEERS**  
Alliance Consulting Engineers, Inc.  
124 Verdine Blvd., Bonaville II, Suite 505 - Greenville, SC 29607  
Phone (864) 294-1740 • Fax (864) 294-1741

SCALE: AS SHOWN  
DATE: JUNE 2019  
SHEET

PROJECT: CIVIL DESIGN PLANS FOR THE CLASS II C&D GREENPOINTE LANDFILL ALONG HAMLIN ROAD LOCATED IN ANDERSON COUNTY, SOUTH CAROLINA  
SCALE: AS SHOWN  
DATE: JUNE 2019  
SHEET

FILE NAME: E16227-PLANS  
REFERENCE FILE: E16227-BASE  
PROJECT NO. 16227-0004  
DWG NO. 01,1168-D21

SHEET C-4.4

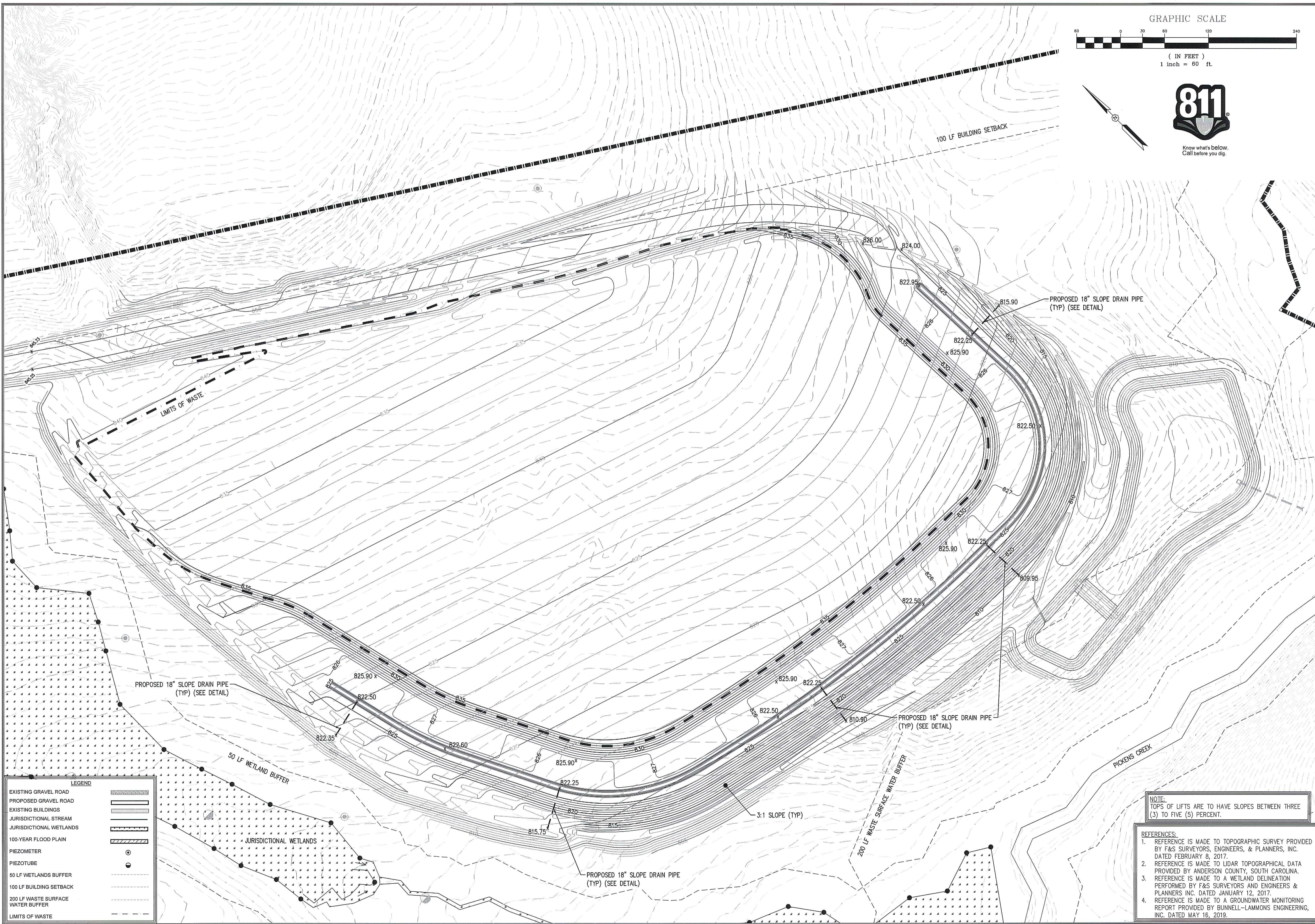

**LEGEND**

EXISTING GRAVEL ROAD	
PROPOSED GRAVEL ROAD	
EXISTING BUILDINGS	
JURISDICTIONAL STREAM	
JURISDICTIONAL WETLANDS	
100-YEAR FLOOD PLAIN	
PIEZOMETER	
PIEZOTUBE	
50 LF WETLANDS BUFFER	
100 LF BUILDING SETBACK	
200 LF WASTE SURFACE WATER BUFFER	
LIMITS OF WASTE	

**NOTE:**  
TOPS OF LIFTS ARE TO HAVE SLOPES BETWEEN THREE (3) TO FIVE (5) PERCENT.

- REFERENCES:**
- REFERENCE IS MADE TO TOPOGRAPHIC SURVEY PROVIDED BY F&S SURVEYORS, ENGINEERS, & PLANNERS, INC. DATED FEBRUARY 8, 2017.
  - REFERENCE IS MADE TO LIDAR TOPOGRAPHICAL DATA PROVIDED BY ANDERSON COUNTY, SOUTH CAROLINA. REFERENCE IS MADE TO A WETLAND DELINEATION PERFORMED BY F&S SURVEYORS AND ENGINEERS & PLANNERS INC. DATED JANUARY 12, 2017.
  - REFERENCE IS MADE TO A GROUNDWATER MONITORING REPORT PROVIDED BY BUNNELL-LAMMONS ENGINEERING, INC. DATED MAY 16, 2019.





**LEGEND**

EXISTING GRAVEL ROAD	
PROPOSED GRAVEL ROAD	
EXISTING BUILDINGS	
JURISDICTIONAL STREAM	
JURISDICTIONAL WETLANDS	
100-YEAR FLOOD PLAIN	
PIEZOMETER	
PIEZOTUBE	
50 LF WETLANDS BUFFER	
100 LF BUILDING SETBACK	
200 LF WASTE SURFACE WATER BUFFER	
LIMITS OF WASTE	

GRAPHIC SCALE  
 ( IN FEET )  
 1 inch = 80 ft.

811  
 Know what's below.  
 Call before you dig.

REVISION DATE	
APPROVALS	DATE
ENGINEER	
RTO	
DESIGNER	
RTO	
TECHNICIAN	
PRJ	
CHECKED BY	
GTF	
APPROVED	
RTO	

SOUTH CAROLINA PROFESSIONAL ENGINEER  
 No. 35683  
 SIGNATURE:

SOUTH CAROLINA PROFESSIONAL ENGINEER  
 No. 02854  
 DATE: 9/23/19

**ALLIANCE CONSULTING ENGINEERS**  
 Alliance Consulting Engineers, Inc.  
 124 Verdae Blvd - Boonville II, Suite 305 - Greenville, SC 29607  
 Phone: (864) 284-1740 • Fax: (864) 284-1741

PROJECT: CIVIL DESIGN PLANS FOR THE CLASS II C&D GREENPOINTE LANDFILL ALONG HAMLIN ROAD LOCATED IN ANDERSON COUNTY, SOUTH CAROLINA

SHEET: FINAL ELEVATION - LIFT 2 GRADING AND STORM DRAINAGE PLAN - CELL 1

DATE: JUNE 2019 SCALE: AS SHOWN

NOTE:  
 TOPS OF LIFTS ARE TO HAVE SLOPES BETWEEN THREE (3) TO FIVE (5) PERCENT.

- REFERENCES:
- REFERENCE IS MADE TO TOPOGRAPHIC SURVEY PROVIDED BY F&S SURVEYORS, ENGINEERS, & PLANNERS, INC. DATED FEBRUARY 8, 2017.
  - REFERENCE IS MADE TO LIDAR TOPOGRAPHICAL DATA PROVIDED BY ANDERSON COUNTY, SOUTH CAROLINA. REFERENCE IS MADE TO A WETLAND DELINEATION PERFORMED BY F&S SURVEYORS AND ENGINEERS & PLANNERS INC. DATED JANUARY 12, 2017.
  - REFERENCE IS MADE TO A GROUNDWATER MONITORING REPORT PROVIDED BY BUNNELL-LAMMONS ENGINEERING, INC. DATED MAY 16, 2019.

FILE NAME:	E16227-PLANS
REFERENCE FILE:	E16227-BASE
PROJECT NO.:	16227-0004
DWG NO.:	01J168-D21
SHEET:	C-45

THIS DOCUMENT IS THE SOLE PROPERTY OF ALLIANCE CONSULTING ENGINEERS, INC. IT IS NOT TO BE REPRODUCED, COPIED OR OTHERWISE DISTRIBUTED WITHOUT THE AUTHORIZATION OF ALLIANCE CONSULTING ENGINEERS, INC. THE DRAWING IS INTENDED SPECIFICALLY FOR THE PROJECT REFERENCED HEREIN AND THAT TRANSFERABLE TO ANOTHER PROJECT.

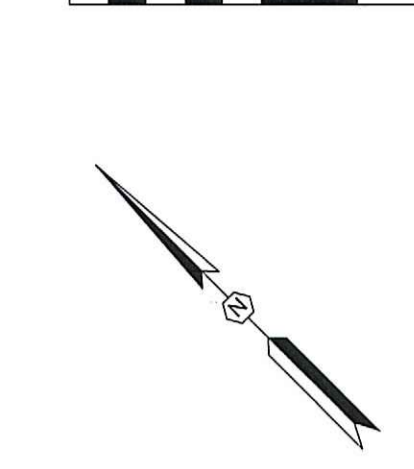
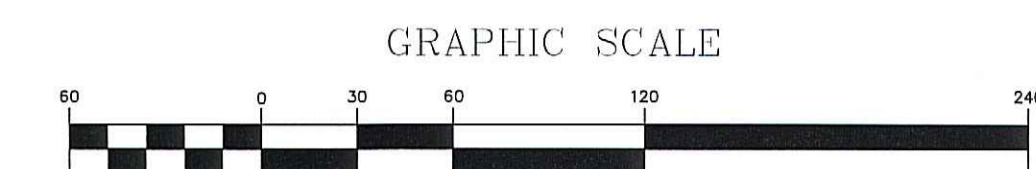

REVISION DATE	

ENGINEER	RTO
DESIGNER	RTO
TECHNICIAN	PSJ
CHECKED BY	GTF
APPROVED	RTO

ALLIANCE CONSULTING ENGINEERS, INC.  
 ENGINEER  
 No. 35683  
 DATE: 9/27/19  
 SIGNATURE:

**ALLIANCE CONSULTING ENGINEERS**  
 Alliance Consulting Engineers, Inc.  
 124 Verdara Blvd., Bonaventure II, Suite 505 - Greenville, SC 29607  
 Phone: (864) 284-7400 Fax: (864) 284-1741

PROJECT: CIVIL DESIGN PLANS FOR THE CLASS II C&D GREENPOINTE LANDFILL ALONG HAMLIN ROAD LOCATED IN ANDERSON COUNTY, SOUTH CAROLINA  
 SHEET: FINAL ELEVATION - LIFT 2 GRADING AND STORM DRAINAGE PLAN - CELL 2  
 DATE: JUNE 2019  
 SCALE: AS SHOWN

FILE NAME: E16227-PLANS  
 REFERENCE FILE: E16227-BASE  
 PROJECT NO.: 16227-0004  
 DWG NO.: 01,1168-D21

SHEET C-4.6

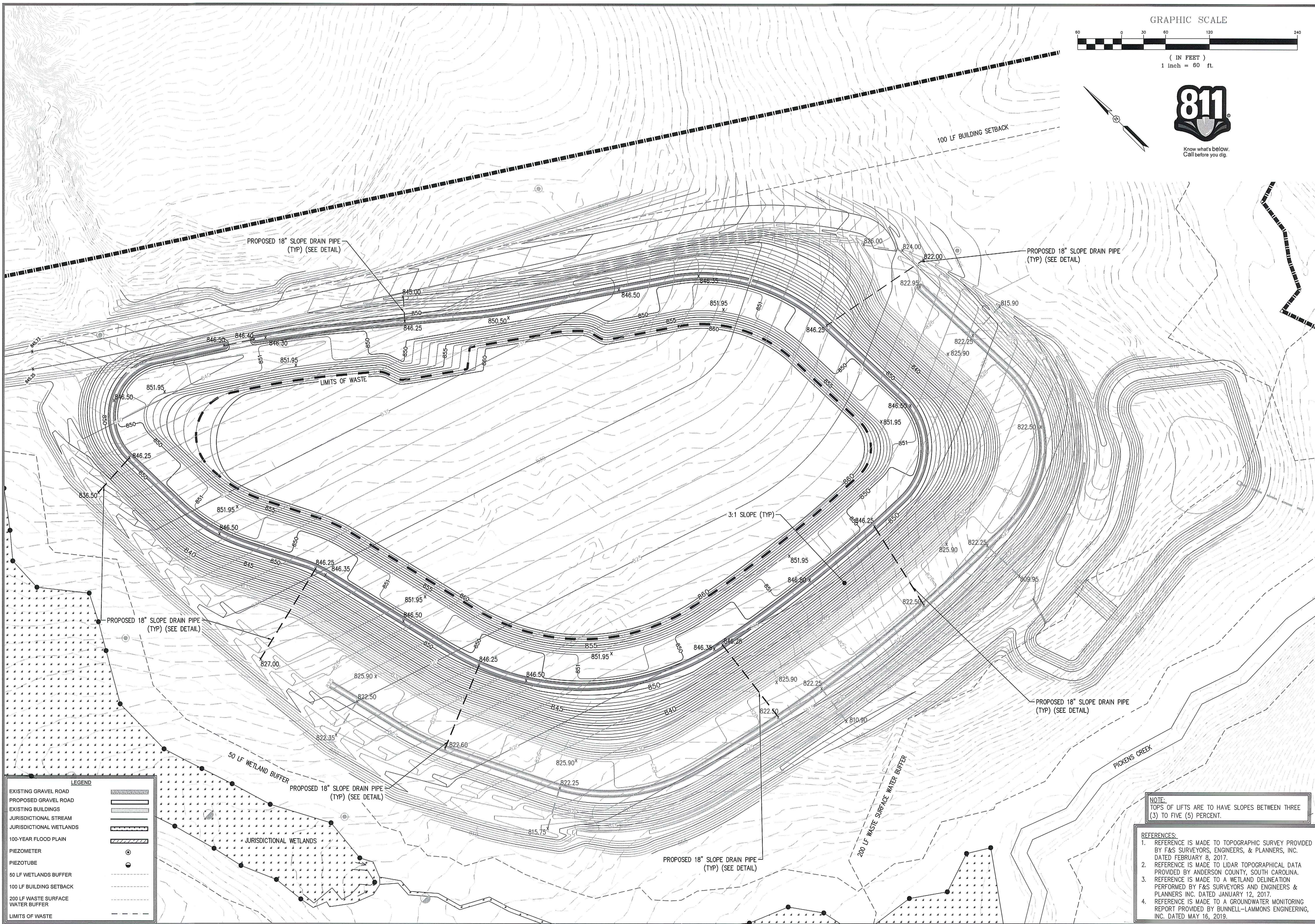

LEGEND	
EXISTING GRAVEL ROAD	
PROPOSED GRAVEL ROAD	
EXISTING BUILDINGS	
JURISDICTIONAL STREAM	
JURISDICTIONAL WETLANDS	
100-YEAR FLOOD PLAIN	
PIEZOMETER	
PIEZOTUBE	
50 LF WETLANDS BUFFER	
100 LF BUILDING SETBACK	
200 LF WASTE SURFACE WATER BUFFER	
LIMITS OF WASTE	

NOTE:  
 TOPS OF LIFTS ARE TO HAVE SLOPES BETWEEN THREE (3) TO FIVE (5) PERCENT.

- REFERENCES:
- REFERENCE IS MADE TO TOPOGRAPHIC SURVEY PROVIDED BY F&S SURVEYORS, ENGINEERS, & PLANNERS, INC. DATED FEBRUARY 8, 2017.
  - REFERENCE IS MADE TO LIDAR TOPOGRAPHICAL DATA PROVIDED BY ANDERSON COUNTY, SOUTH CAROLINA. PERFORMED BY F&S SURVEYORS AND ENGINEERS & PLANNERS, INC. DATED JANUARY 12, 2017.
  - REFERENCE IS MADE TO A WETLAND DELINEATION REPORT PROVIDED BY BUNNELL-LAMMONS ENGINEERING, INC. DATED MAY 16, 2019.

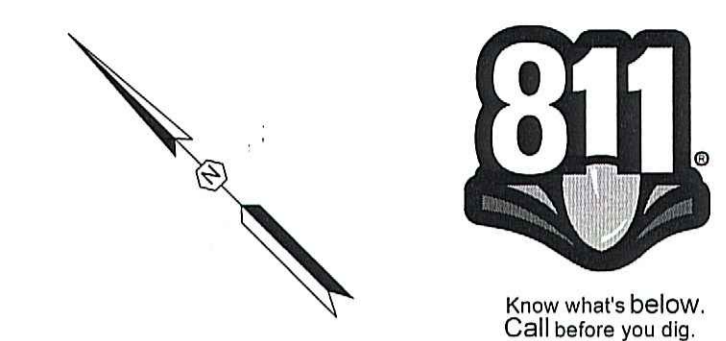
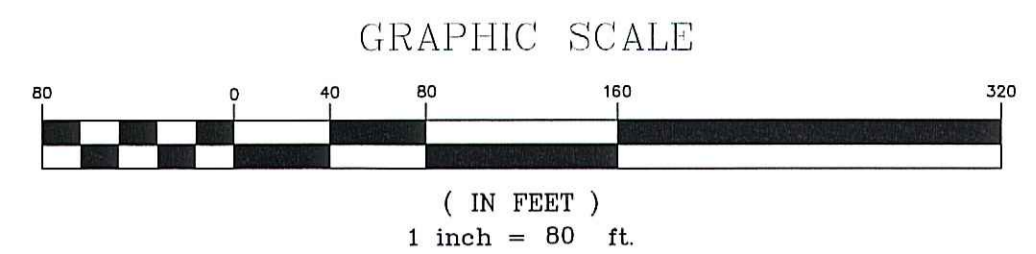

REVISION DATE	

APPROVALS

DESIGNER	RTO	CHECKED BY	GTF	APPROVED	RTO
DESIGNER	RTO	CHECKED BY	GTF	APPROVED	RTO
TELEVISION	PSI	CHECKED BY	GTF	APPROVED	RTO

SCHEMATIC

DATE: 9/22/19

**ALLIANCE CONSULTING ENGINEERS**

Alliance Consulting Engineers, Inc.  
 124 Verdae Blvd. - Bonaville II, Suite 305 - Greenville, SC 29607  
 Phone: (867) 284-1746 Fax: (867) 284-1741

PROJECT: CIVIL DESIGN PLANS FOR THE CLASS II C&D GREENPONT LANDFILL ALONG HAMLIN ROAD LOCATED IN ANDERSON COUNTY, SOUTH CAROLINA

SCALE: AS SHOWN

FILE NAME: E16227-PLANS

REFERENCE FILE: E16227-BASE

PROJECT NO. 16227-004

DWG NO. 01.1168-D21

SHEET C-47

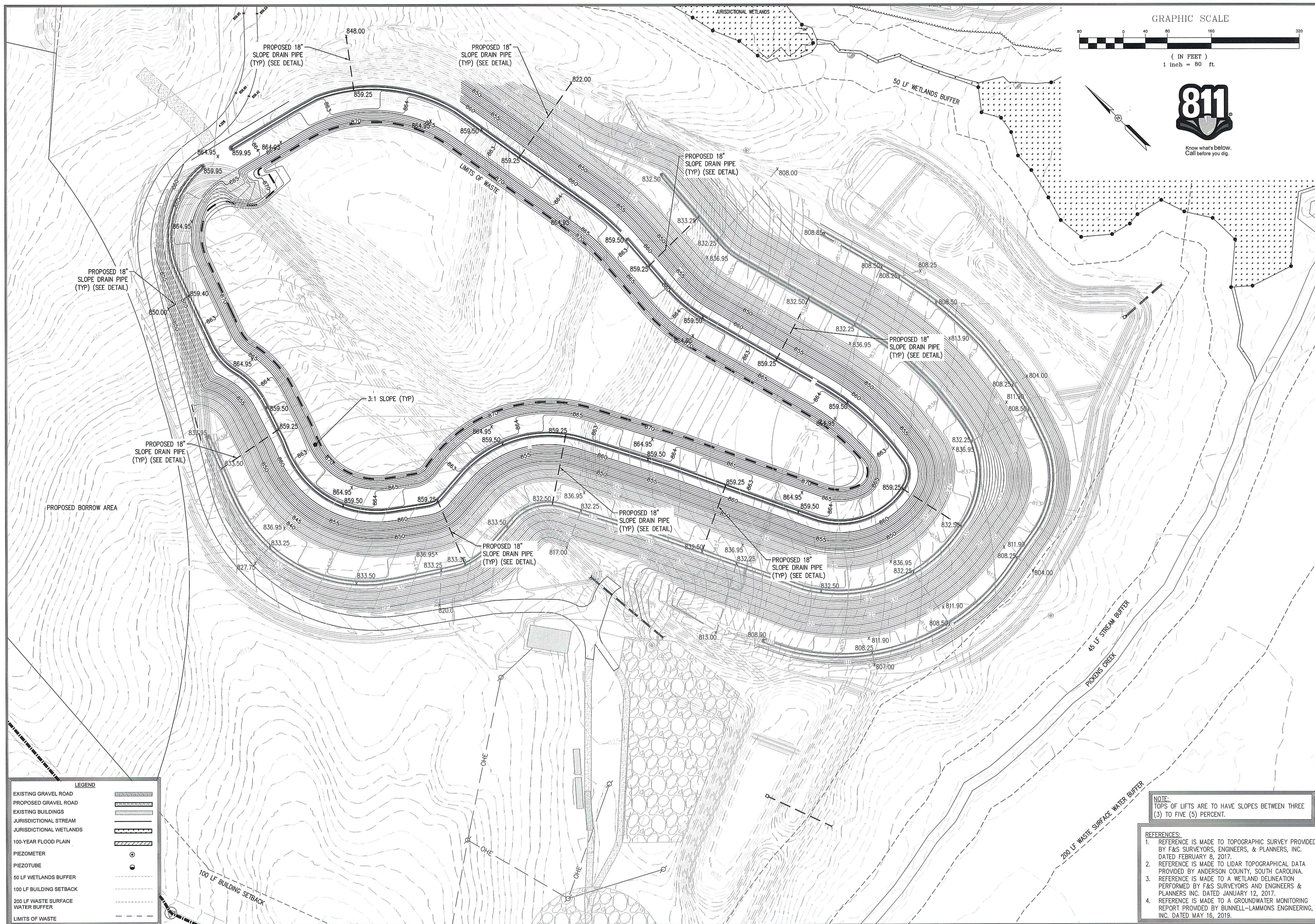

LEGEND

EXISTING GRAVEL ROAD	
PROPOSED GRAVEL ROAD	
EXISTING BUILDINGS	
JURISDICTIONAL STREAM	
JURISDICTIONAL WETLANDS	
100-YEAR FLOOD PLAIN	
PIEZOMETER	
PIEZOTUBE	
50 LF WETLANDS BUFFER	
100 LF BUILDING SETBACK	
200 LF WASTE SURFACE WATER BUFFER	
LIMITS OF WASTE	

NOTE:  
TOPS OF LIFTS ARE TO HAVE SLOPES BETWEEN THREE (3) TO FIVE (5) PERCENT.

- REFERENCES:
- REFERENCE IS MADE TO TOPOGRAPHIC SURVEY PROVIDED BY F&S SURVEYORS, ENGINEERS, & PLANNERS, INC. DATED FEBRUARY 8, 2017.
  - REFERENCE IS MADE TO LIDAR TOPOGRAPHICAL DATA PROVIDED BY ANDERSON COUNTY, SOUTH CAROLINA.
  - REFERENCE IS MADE TO A WETLAND DELINEATION PERFORMED BY F&S SURVEYORS AND ENGINEERS & PLANNERS INC. DATED JANUARY 12, 2017.
  - REFERENCE IS MADE TO A GROUNDWATER MONITORING REPORT PROVIDED BY BUNNELL-LAMMONS ENGINEERING, INC. DATED MAY 16, 2019.

THIS DOCUMENT IS THE SOLE PROPERTY OF ALLIANCE CONSULTING ENGINEERS, INC. IT IS NOT TO BE REPRODUCED, COPIED OR OTHERWISE EDITED WITHOUT THE AUTHORIZATION OF ALLIANCE CONSULTING ENGINEERS, INC. THIS DOCUMENT IS INTENDED FOR THE PROJECT AND SITE SPECIFICALLY IDENTIFIED HEREIN AND IS NOT TO BE REPRODUCED TO ANY OTHER PROJECT.

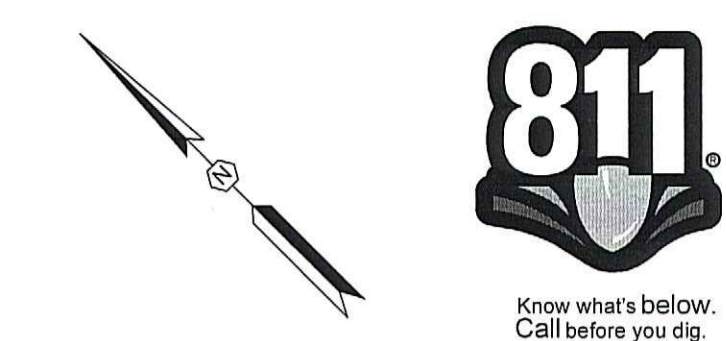
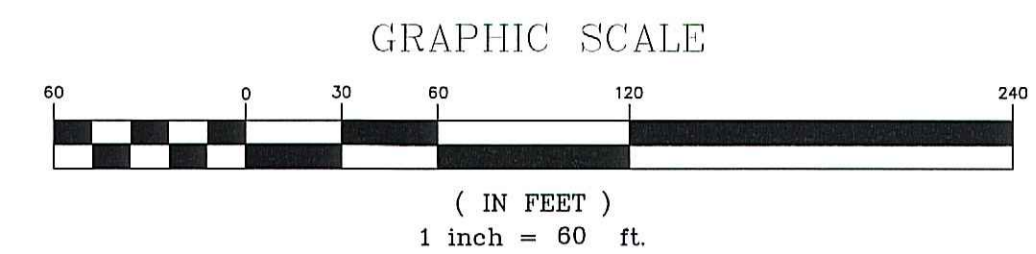
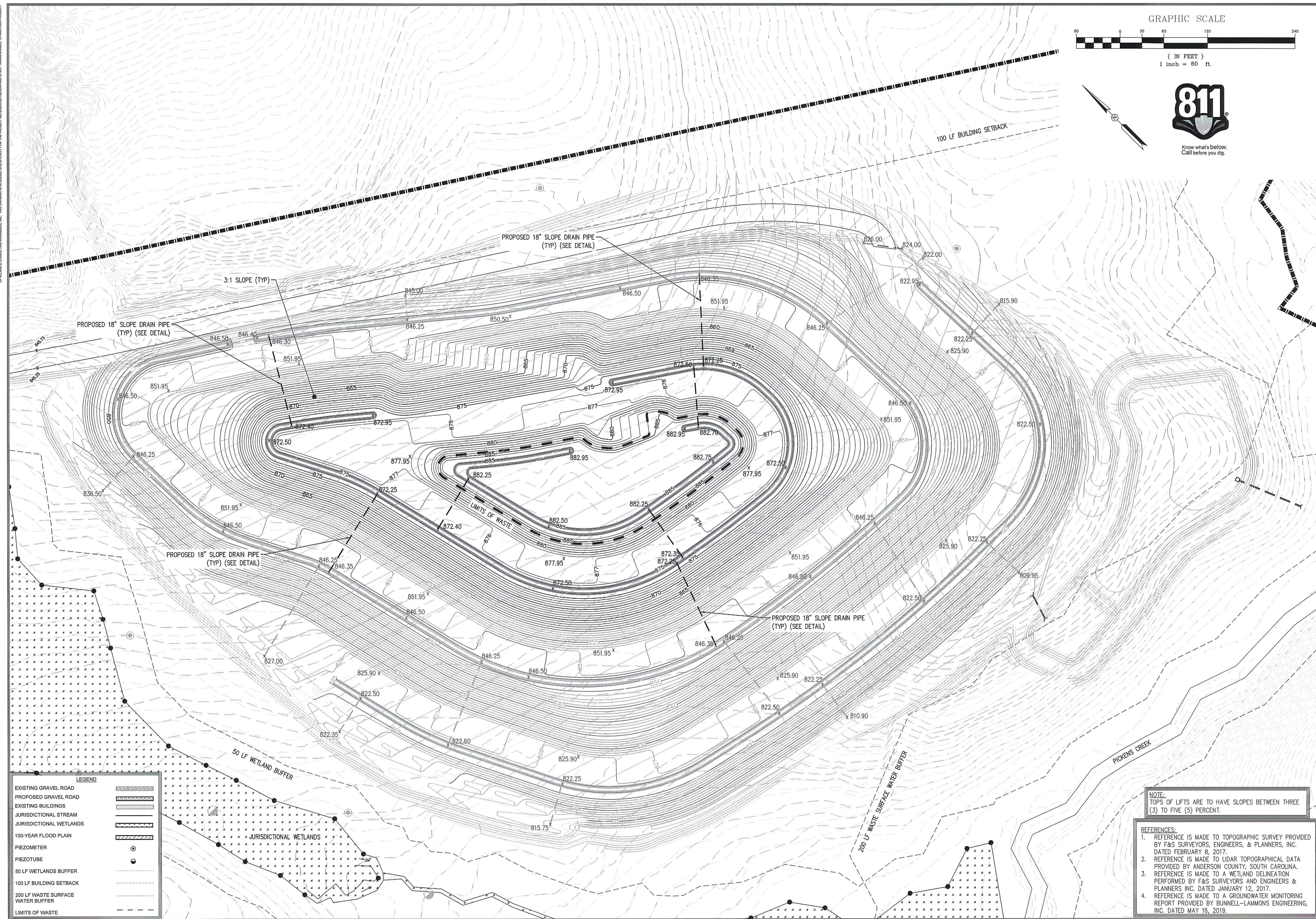

**LEGEND**

EXISTING GRAVEL ROAD	
PROPOSED GRAVEL ROAD	
EXISTING BUILDINGS	
JURISDICTIONAL STREAM	
JURISDICTIONAL WETLANDS	
100-YEAR FLOOD PLAIN	
PIEZOMETER	
PIEZOTUBE	
50 LF WETLANDS BUFFER	
100 LF BUILDING SETBACK	
200 LF WASTE SURFACE WATER BUFFER	
LIMITS OF WASTE	

**NOTE:**  
TOPS OF LIFTS ARE TO HAVE SLOPES BETWEEN THREE (3) TO FIVE (5) PERCENT.

- REFERENCES:**
- REFERENCE IS MADE TO TOPOGRAPHIC SURVEY PROVIDED BY F&S SURVEYORS, ENGINEERS, & PLANNERS, INC. DATED FEBRUARY 8, 2017.
  - REFERENCE IS MADE TO LIDAR TOPOGRAPHICAL DATA PROVIDED BY ANDERSON COUNTY, SOUTH CAROLINA. REFERENCE IS MADE TO A WETLAND DELINEATION PERFORMED BY F&S SURVEYORS AND ENGINEERS & PLANNERS INC. DATED JANUARY 12, 2017.
  - REFERENCE IS MADE TO A GROUNDWATER MONITORING REPORT PROVIDED BY BUNNELL-LAMMONS ENGINEERING, INC. DATED MAY 16, 2019.

APPROVALS		REVISION DATE
ENGINEER	RTO	
DESIGNER	RTO	
TECHNICIAN	PRJ	
CHECKED BY	GTF	
APPROVED	RTO	

DATE: 9/22/19

**ALLIANCE CONSULTING ENGINEERS**  
Alliance Consulting Engineers, Inc.  
124 Verdade Blvd., Bonaventure II, Suite 505 - Greenville, SC 29607  
Phone: (864) 284-1740 • Fax: (864) 284-1741

PROJECT: CIVIL DESIGN PLANS FOR THE CLASS II C&D GREENPOINTE LANDFILL ALONG HAMLIN ROAD LOCATED IN ANDERSON COUNTY, SOUTH CAROLINA.

SCALE: AS SHOWN

DATE: JUNE 2019

FILE NAME:	E16227-PLANS
REFERENCE FILE:	E16227-BASE
PROJECT NO.:	16227-0004
DWG NO.:	01.I168-D21

SHEET C-4.8

THIS DOCUMENT IS THE SOLE PROPERTY OF ALLIANCE CONSULTING ENGINEERS, INC. IT IS NOT TO BE REPRODUCED, COPIED OR OTHERWISE DISTRIBUTED OUTSIDE OF THE JURISDICTION OF ALLIANCE CONSULTING ENGINEERS, INC. THIS DRAWING IS INTENDED SPECIFICALLY FOR THE PROJECT REFERENCED HEREIN AND IS NOT TRANSFERABLE TO ANOTHER PROJECT.

GRAPHIC SCALE  
( IN FEET )  
1 inch = 80 ft.

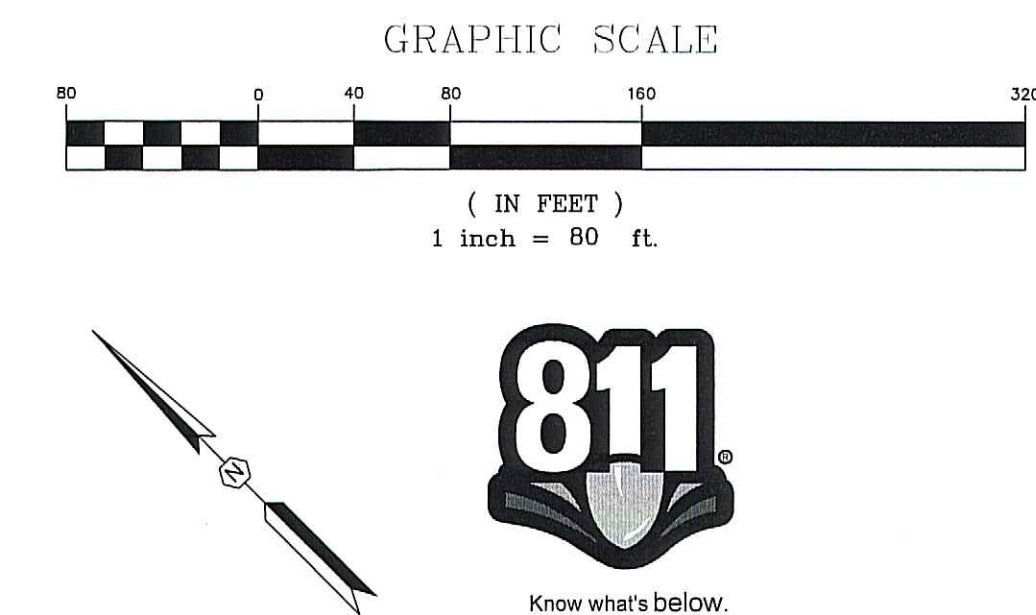

REVISION DATE	

APPROVALS

ENGINEER	RTO
DESIGNER	RTO
TECHNICAL	PRJ
CHECKED BY	GTF
APPROVED	RTO

DATE: 9/27/19

PROFESSIONAL SEAL

RES. AN. 35683

SIGNATURE: [Signature]

**ALLIANCE CONSULTING ENGINEERS**  
Alliance Consulting Engineers, Inc.  
124 Verdare Blvd - Bonaventure II, Suite 505 - Greenville, SC 29607  
Phone: (864) 284-1744 Fax: (864) 284-1741

PROJECT: CIVIL DESIGN PLANS FOR THE CLASS II C&D GREENPOINTE LANDFILL ALONG HAMLIN ROAD LOCATED IN ANDERSON COUNTY, SOUTH CAROLINA

SHEET: FINAL ELEVATION - LIFT 4 GRADING AND STORM DRAINAGE PLAN - CELL 1

DATE: JUNE 2019

SCALE: AS SHOWN

FILE NAME: E16227-PLANS

REFERENCE FILE: E16227-BASE

PROJECT NO: 16227-0004

SHEET: C-49

DWG NO. 01.1168-D21

LEGEND

EXISTING GRAVEL ROAD	
PROPOSED GRAVEL ROAD	
EXISTING BUILDINGS	
JURISDICTIONAL STREAM	
JURISDICTIONAL WETLANDS	
100-YEAR FLOOD PLAIN	
PIEZOMETER	
PIEZOTUBE	
50 LF WETLANDS BUFFER	
100 LF BUILDING SETBACK	
200 LF WASTE SURFACE WATER BUFFER	
LIMITS OF WASTE	

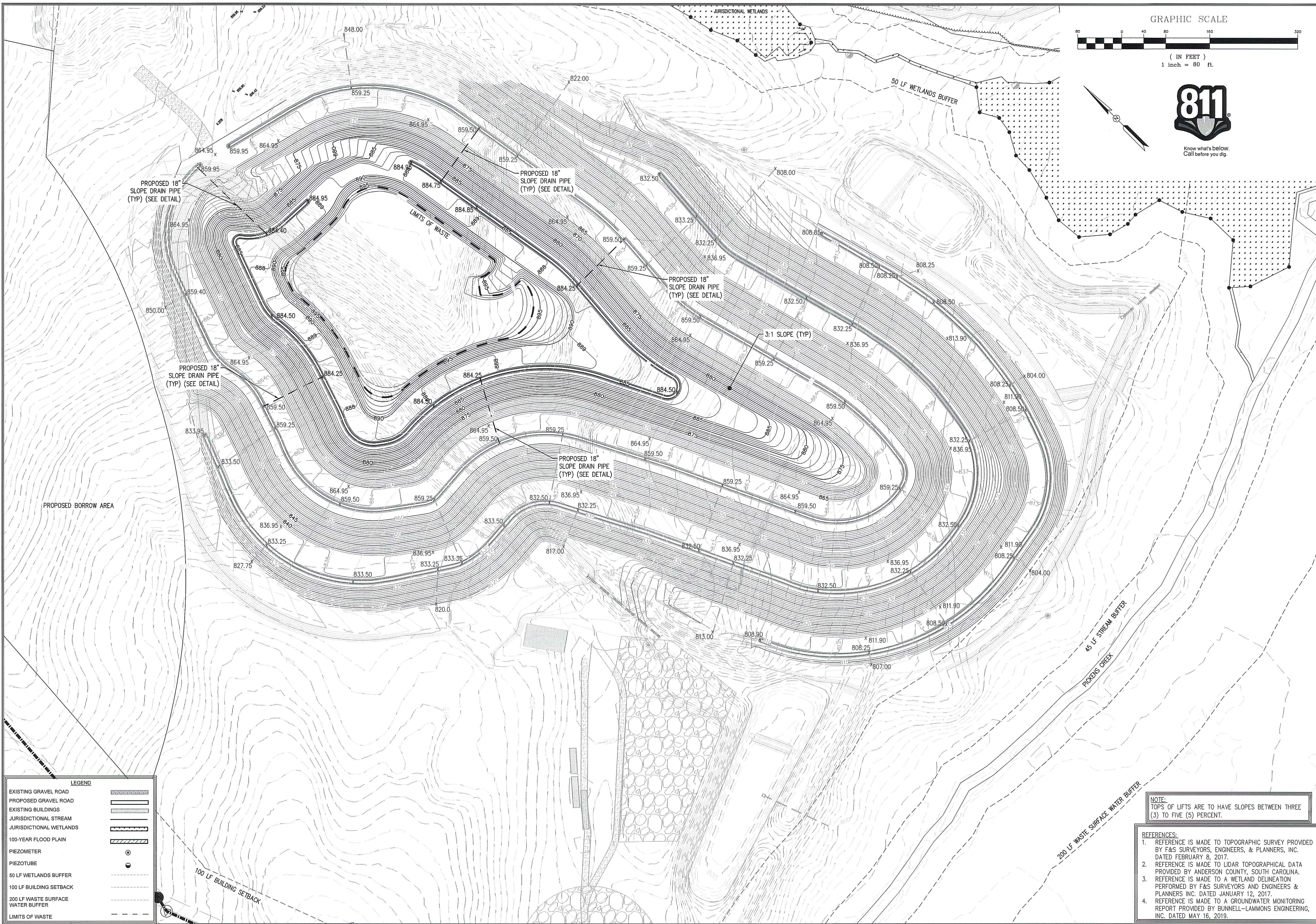

NOTE:  
TOPS OF LIFTS ARE TO HAVE SLOPES BETWEEN THREE (3) TO FIVE (5) PERCENT.

- REFERENCES:
1. REFERENCE IS MADE TO TOPOGRAPHIC SURVEY PROVIDED BY F&S SURVEYORS, ENGINEERS, & PLANNERS, INC. DATED FEBRUARY 8, 2017.
  2. REFERENCE IS MADE TO LIDAR TOPOGRAPHICAL DATA PROVIDED BY ANDERSON COUNTY, SOUTH CAROLINA. PERFORMED BY F&S SURVEYORS AND ENGINEERS & PLANNERS INC. DATED JANUARY 12, 2017.
  3. REFERENCE IS MADE TO A WETLAND DELINEATION REPORT PROVIDED BY BUNNELL-LAMMONS ENGINEERING, INC. DATED MAY 16, 2019.

THIS DOCUMENT IS THE SOLE PROPERTY OF ALLIANCE CONSULTING ENGINEERS, INC. IT IS NOT TO BE REPRODUCED, COPIED OR OTHERWISE ENTERED INTO THE AUTOMATION OF ANY INFORMATION SYSTEM WITHOUT THE WRITTEN PERMISSION OF ALLIANCE CONSULTING ENGINEERS, INC. THIS DOCUMENT IS PROVIDED AS A SERVICE TO THE CLIENT AND IS NOT TO BE REPRODUCED OR TRANSMITTED IN ANY FORM OR BY ANY MEANS, ELECTRONIC OR MECHANICAL, INCLUDING PHOTOCOPYING, RECORDING, OR BY ANY INFORMATION STORAGE AND RETRIEVAL SYSTEM.

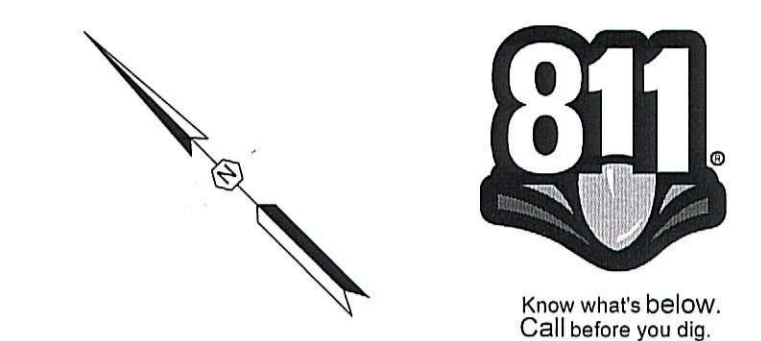
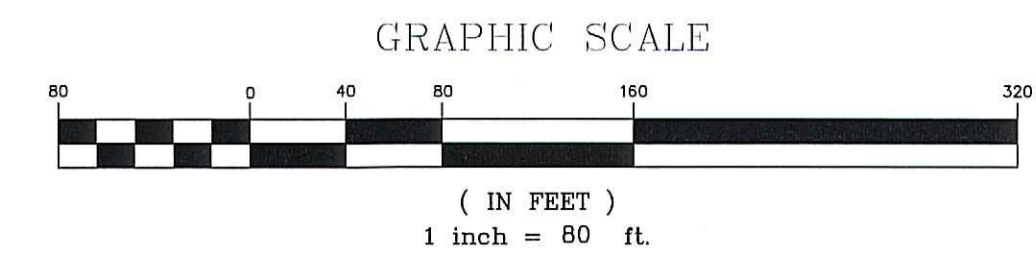
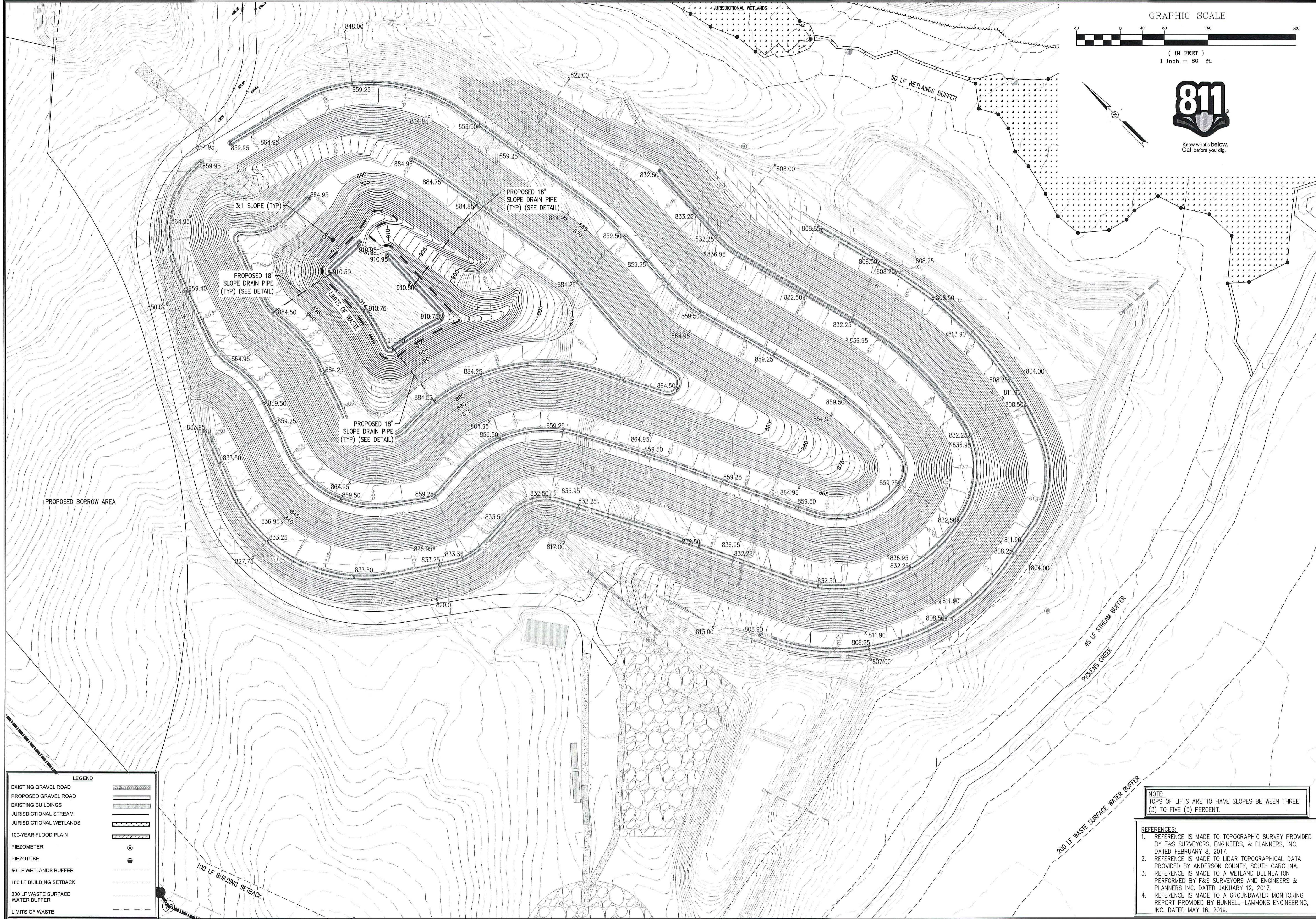

REVISION DATE	

APPROVALS

ENGINEER	RTO	DESIGNER	RTO	TECHNICIAN	PRJ	CHECKED BY	GTF	APPROVED	RTO
----------	-----	----------	-----	------------	-----	------------	-----	----------	-----

DATE: 6/27/19

ALLIANCE CONSULTING ENGINEERS, INC. No. 35683

SIGNATURE: [Signature]

**ALLIANCE CONSULTING ENGINEERS**

Alliance Consulting Engineers, Inc.  
124 Verdac Blvd. - Bonaventure II, Suite 505 - Greenville, SC 29607  
Phone (864) 284-1740 Fax (864) 284-1741

SCALE: AS SHOWN

DATE: JUNE 2019

SHEET

FINAL ELEVATION - LIFT 5  
GRADING AND STORM  
DRAINAGE PLAN - CELL 1

CIVIL DESIGN PLANS FOR THE  
CLASS II C&D  
GREENPOINTE LANDFILL  
ALONG HAMLIN ROAD  
LOCATED IN  
ANDERSON COUNTY,  
SOUTH CAROLINA

PROJECT: CIVIL DESIGN PLANS FOR THE CLASS II C&D GREENPOINTE LANDFILL ALONG HAMLIN ROAD LOCATED IN ANDERSON COUNTY, SOUTH CAROLINA

FILE NAME: E16227-PLANS

REFERENCE FILE: E16227-BASE

PROJECT NO. I6227-0004

DWG NO. 01,1168-D21

**LEGEND**

EXISTING GRAVEL ROAD	
PROPOSED GRAVEL ROAD	
EXISTING BUILDINGS	
JURISDICTIONAL STREAM	
JURISDICTIONAL WETLANDS	
100-YEAR FLOOD PLAIN	
PIEZOMETER	
PIEZOTUBE	
50 LF WETLANDS BUFFER	
100 LF BUILDING SETBACK	
200 LF WASTE SURFACE WATER BUFFER	
LIMITS OF WASTE	

**NOTE:**  
TOPS OF LIFTS ARE TO HAVE SLOPES BETWEEN THREE (3) TO FIVE (5) PERCENT.

- REFERENCES:**
- REFERENCE IS MADE TO TOPOGRAPHIC SURVEY PROVIDED BY F&S SURVEYORS, ENGINEERS, & PLANNERS, INC. DATED FEBRUARY 8, 2017.
  - REFERENCE IS MADE TO LIDAR TOPOGRAPHICAL DATA PROVIDED BY ANDERSON COUNTY, SOUTH CAROLINA.
  - REFERENCE IS MADE TO A WETLAND DELINEATION PERFORMED BY F&S SURVEYORS AND ENGINEERS & PLANNERS INC. DATED JANUARY 12, 2017.
  - REFERENCE IS MADE TO A GROUNDWATER MONITORING REPORT PROVIDED BY BUNNELL-LAMMONS ENGINEERING, INC. DATED MAY 16, 2019.

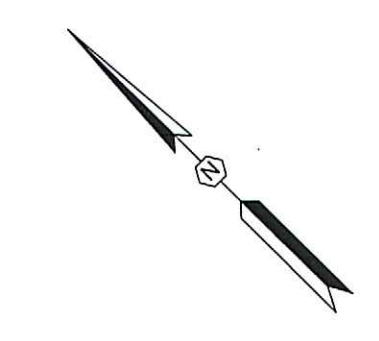
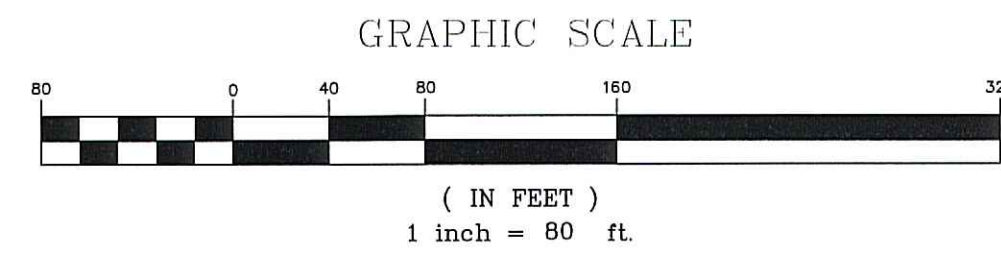

REVISION	
NO.	DATE

APPROVALS:

ENGINEER	RTO
DESIGNER	RTO
TECHNICIAN	PIJ
CHECKED BY	GTF
APPROVED	RTO

DATE: 6/27/19

REGISTERED PROFESSIONAL ENGINEER

SOUTH CAROLINA ENGINEER

No. 35683

DATE: 6/27/19

**ALLIANCE CONSULTING ENGINEERS**

Alliance Consulting Engineers, Inc.  
 124 Verdae Blvd - Bonaville II, Suite 303 - Greenville, SC 29607  
 Phone: (864) 284-1740 • Fax: (864) 284-1741

PROJECT: CIVIL DESIGN PLANS FOR THE CLASS II C&D GREENPOINTE LANDFILL ALONG HAMLIN ROAD LOCATED IN ANDERSON COUNTY, SOUTH CAROLINA.

SCALE: AS SHOWN

DATE: JUNE 2019

PROJECT: CIVIL DESIGN PLANS FOR THE CLASS II C&D GREENPOINTE LANDFILL ALONG HAMLIN ROAD LOCATED IN ANDERSON COUNTY, SOUTH CAROLINA.

FILE NAME: E16227-PLANS

REFERENCE FILE: E16227-BASE

PROJECT NO.: 16227-0004

DWG NO. 01.1168-D21



- REFERENCES:
- REFERENCE IS MADE TO TOPOGRAPHIC SURVEY PROVIDED BY F&S SURVEYORS, ENGINEERS, & PLANNERS, INC. DATED FEBRUARY 8, 2017.
  - REFERENCE IS MADE TO LIDAR TOPOGRAPHICAL DATA PROVIDED BY ANDERSON COUNTY, SOUTH CAROLINA.
  - REFERENCE IS MADE TO A WETLAND DELINEATION PERFORMED BY F&S SURVEYORS AND ENGINEERS & PLANNERS INC. DATED JANUARY 12, 2017.
  - REFERENCE IS MADE TO A GROUNDWATER MONITORING REPORT PROVIDED BY BUNNELL-LAMMONS ENGINEERING, INC. DATED MAY 16, 2019.

THE INFORMATION ON THIS PLAN IS THE PROPERTY OF ALLIANCE CONSULTING ENGINEERS, INC. IT IS TO BE USED ONLY FOR THE PROJECT AND SITE SPECIFICALLY IDENTIFIED HEREON AND IS NOT TO BE REPRODUCED OR TRANSMITTED IN ANY FORM OR BY ANY MEANS, ELECTRONIC OR MECHANICAL, INCLUDING PHOTOCOPYING, RECORDING, OR BY ANY INFORMATION STORAGE AND RETRIEVAL SYSTEM, WITHOUT THE WRITTEN PERMISSION OF ALLIANCE CONSULTING ENGINEERS, INC. THIS DOCUMENT IS INTENDED TO BE USED ONLY FOR THE PROJECT AND SITE SPECIFICALLY IDENTIFIED HEREON AND IS NOT TO BE REPRODUCED OR TRANSMITTED IN ANY FORM OR BY ANY MEANS, ELECTRONIC OR MECHANICAL, INCLUDING PHOTOCOPYING, RECORDING, OR BY ANY INFORMATION STORAGE AND RETRIEVAL SYSTEM, WITHOUT THE WRITTEN PERMISSION OF ALLIANCE CONSULTING ENGINEERS, INC.

THIS DOCUMENT IS THE SOLE PROPERTY OF ALLIANCE CONSULTING ENGINEERS, INC. IT IS NOT TO BE REPRODUCED, COPIED OR OTHERWISE EDITED WITHOUT THE AUTHORIZATION OF ALLIANCE CONSULTING ENGINEERS, INC. THIS DRAWING IS INTENDED SPECIFICALLY FOR THE PROJECT REFERENCED HEREIN AND IS NOT TRANSFERABLE TO ANOTHER PROJECT.

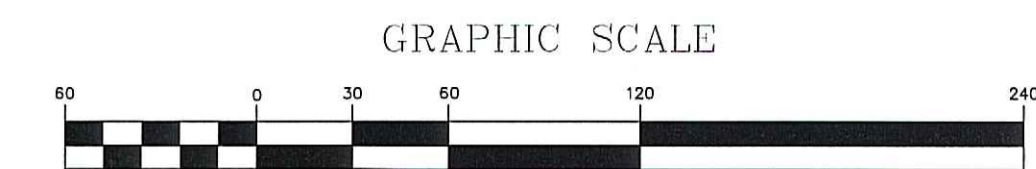

( IN FEET )  
1 inch = 60 ft.



Know what's below.  
Call before you dig.

REVISION DATE	

APPROVALS

ENGINEER	RTO
DESIGNER	RTO
REGISTERED PROFESSIONAL	PRJ
CHECKED BY	GTF
APPROVED	RTO

ALLIANCE CONSULTING ENGINEERS, INC.  
Engineers, Inc. No. 00854

DATE: 9/27/19

ALLIANCE CONSULTING ENGINEERS, INC.  
Alliance Consulting Engineers, Inc.  
1234 Verdade Blvd., Boonville, IL, Suite 505 - Greenville, SC 29607  
Phone: (864) 284-1700 Fax: (864) 284-1741

PROJECT: CIVIL DESIGN PLANS FOR THE CLASS II C&D GREENPOINTE LANDFILL ALONG HAMLIN ROAD LOCATED IN ANDERSON COUNTY, SOUTH CAROLINA

SCALE: AS SHOWN

DATE: JUNE 2019

SHEET: BASE ELEVATION EROSION AND SEDIMENT CONTROL PLAN - CELL 2

FILE NAME: E16227-PLANS  
REFERENCE FILE: E16227-BASE  
PROJECT NO: 16227-0004  
DWG NO. 01.1168-D21

SHEET C-51

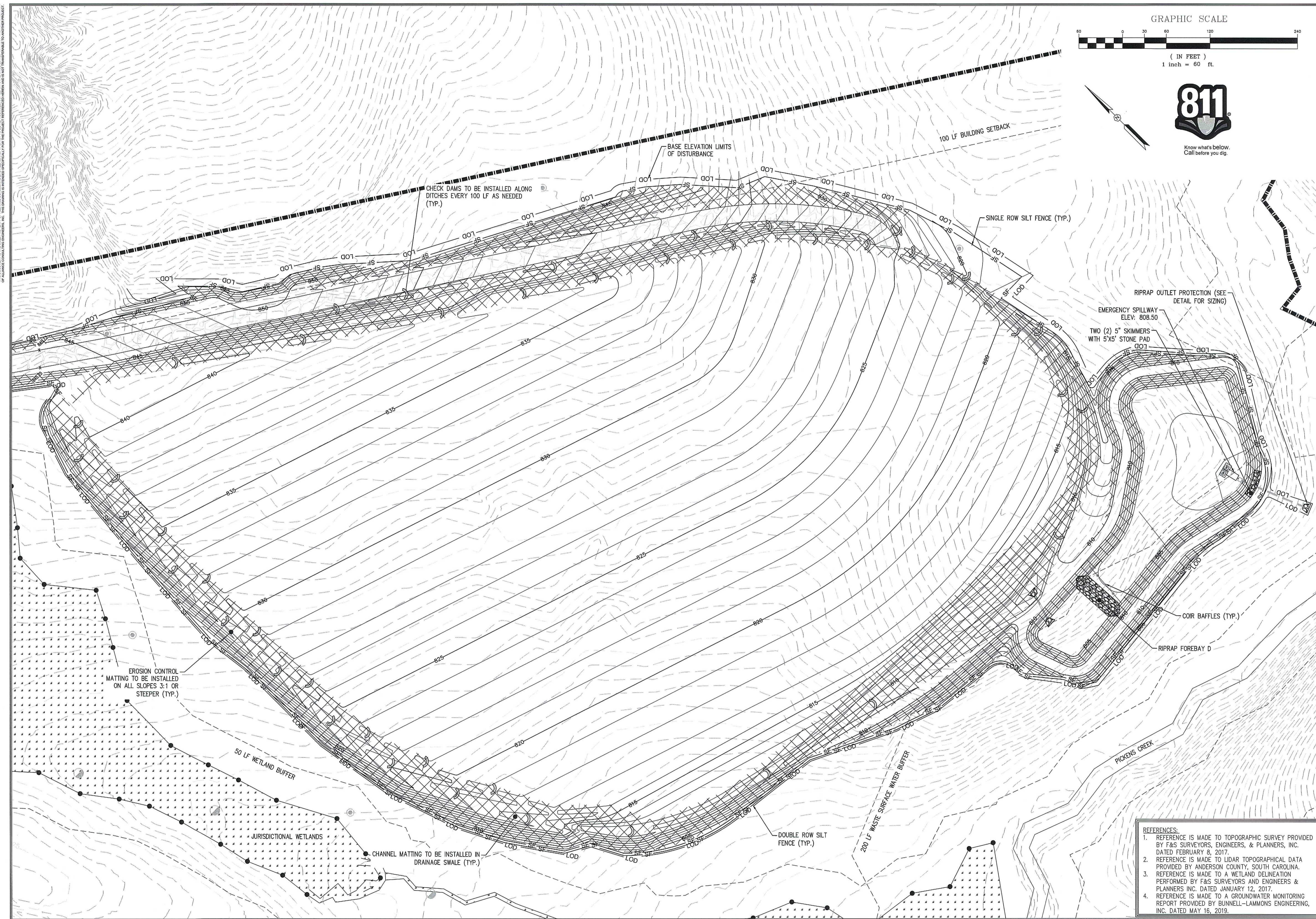

- REFERENCES:
1. REFERENCE IS MADE TO TOPOGRAPHIC SURVEY PROVIDED BY F&S SURVEYORS, ENGINEERS, & PLANNERS, INC. DATED FEBRUARY 8, 2017.
  2. REFERENCE IS MADE TO LIDAR TOPOGRAPHICAL DATA PROVIDED BY ANDERSON COUNTY, SOUTH CAROLINA. REFERENCE IS MADE TO A WETLAND DELINEATION PERFORMED BY F&S SURVEYORS AND ENGINEERS & PLANNERS INC. DATED JANUARY 12, 2017.
  3. REFERENCE IS MADE TO A GROUNDWATER MONITORING REPORT PROVIDED BY BUNNELL-LAMMONS ENGINEERING, INC. DATED MAY 16, 2019.



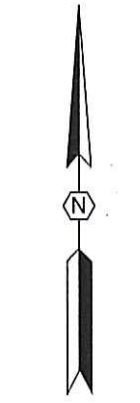
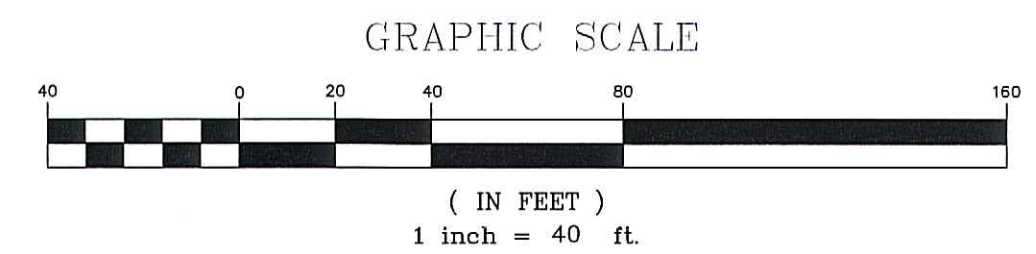

REVISION DATE	

APPROVALS

ENGINEER	RTO	DESIGNER	RTO	TECHNICIAN	PRJ	CHECKED BY	GTF	APPROVED	RTO
----------	-----	----------	-----	------------	-----	------------	-----	----------	-----

DATE: 9/27/19

SCOTT CARROLL, P.E.  
No. 35683

SIGNATURE: [Signature]

**ALLIANCE CONSULTING ENGINEERS**  
Alliance Consulting Engineers, Inc.  
124 Verdier Blvd. - Bonaville II, Suite 305 - Greenville, SC 29607  
Phone (864) 294-1746 Fax (864) 294-1741

SCALE: AS SHOWN  
DATE: JUNE 2019  
SHEET

PROJECT: CIVIL DESIGN PLANS FOR THE CLASS II C&D GREENPONT LANDFILL ALONG HAMLIN ROAD LOCATED IN ANDERSON COUNTY, SOUTH CAROLINA.  
ANDERSON COUNTY SOUTH CAROLINA

FILE NAME: E16227-PLANS  
REFERENCE FILE: E16227-BASE  
PROJECT NO.: 16227-004  
DWG NO. 01.1168-D21

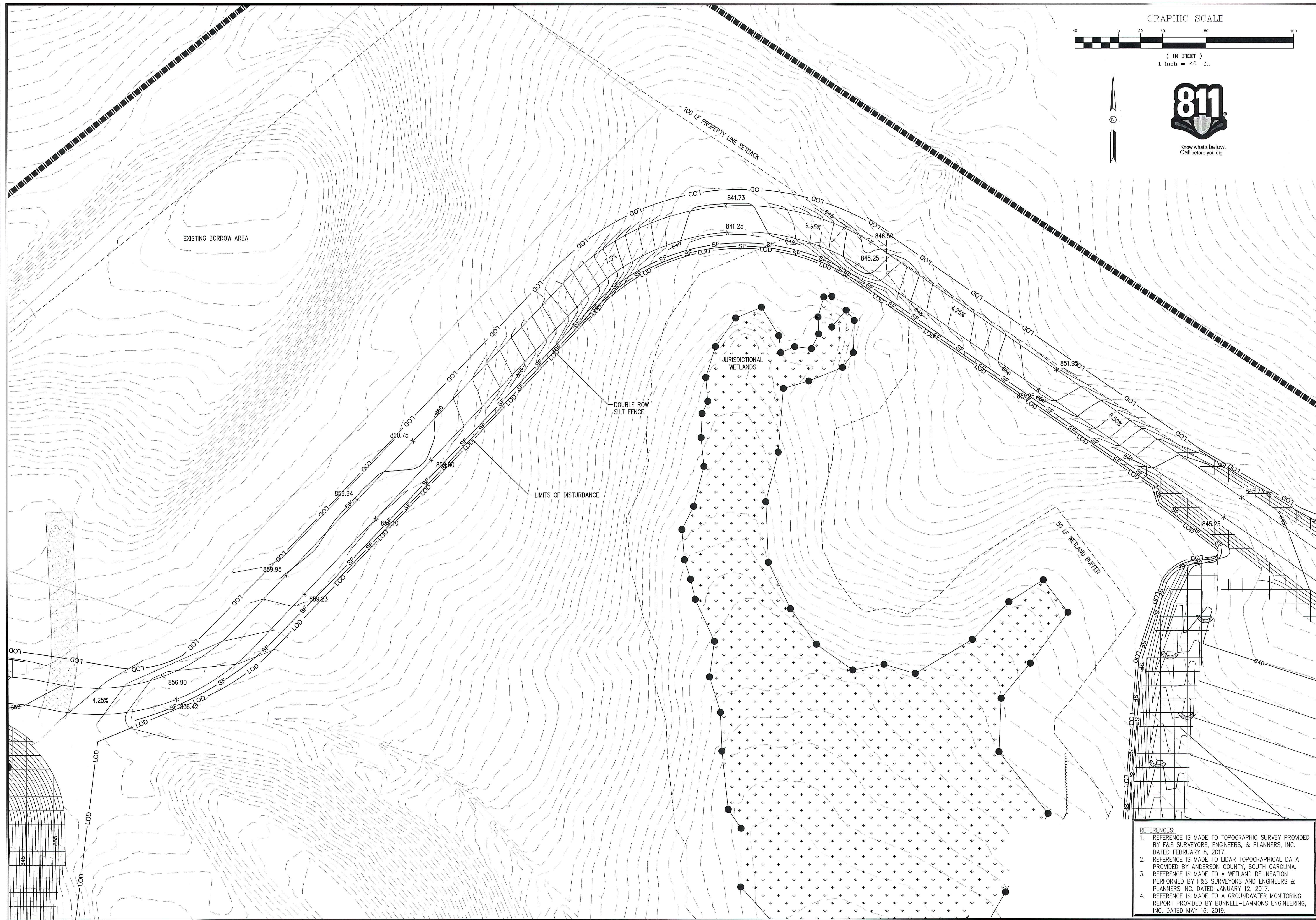

- REFERENCES:
1. REFERENCE IS MADE TO TOPOGRAPHIC SURVEY PROVIDED BY F&S SURVEYORS, ENGINEERS, & PLANNERS, INC. DATED FEBRUARY 8, 2017.
  2. REFERENCE IS MADE TO LIDAR TOPOGRAPHICAL DATA PROVIDED BY ANDERSON COUNTY, SOUTH CAROLINA.
  3. REFERENCE IS MADE TO A WETLAND DELINEATION PERFORMED BY F&S SURVEYORS AND ENGINEERS & PLANNERS INC. DATED JANUARY 12, 2017.
  4. REFERENCE IS MADE TO A GROUNDWATER MONITORING REPORT PROVIDED BY BUNNELL-LAMMONS ENGINEERING, INC. DATED MAY 16, 2019.

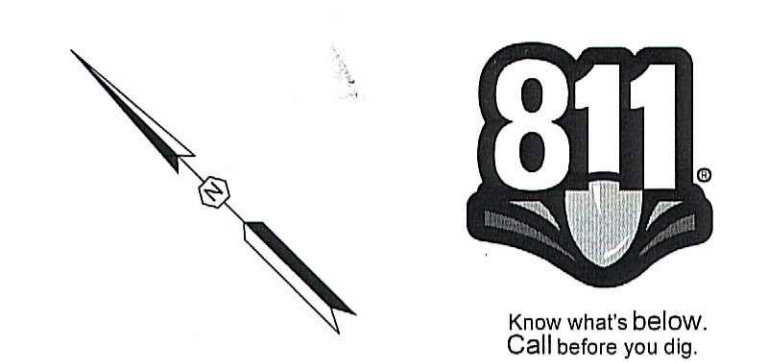
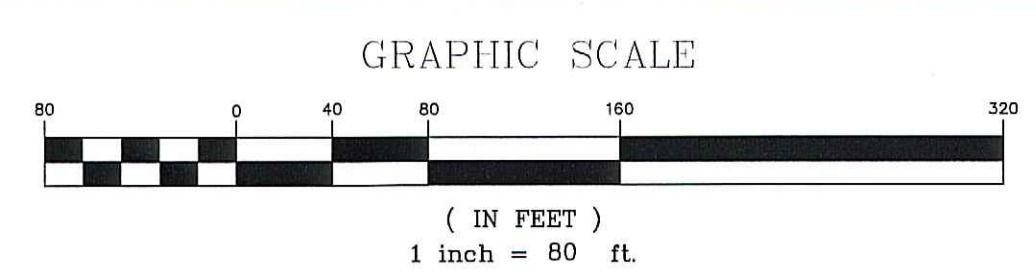
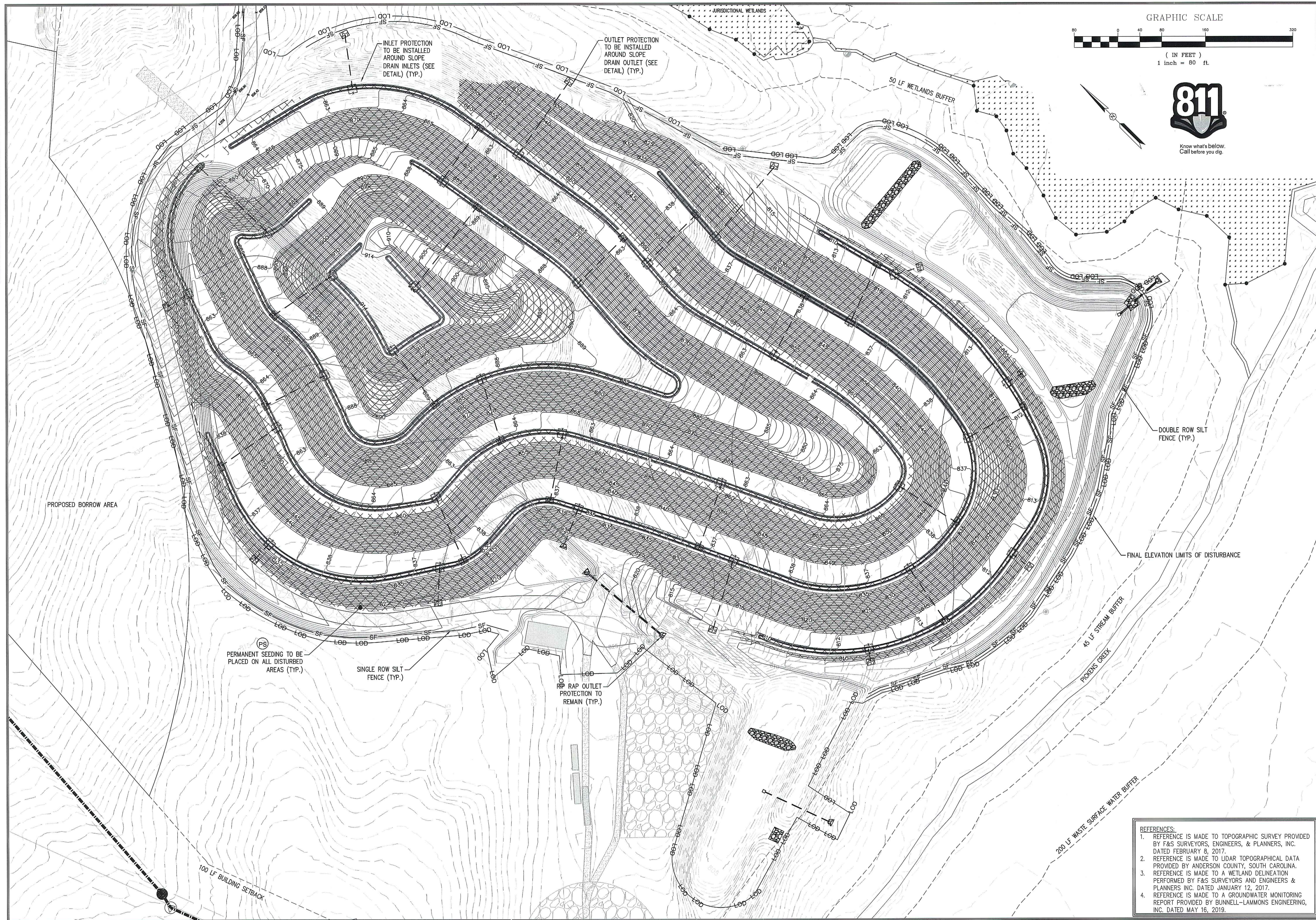

REVISION	
NO.	DATE

APPROVALS:

ENGINEER	RTO
DESIGNER	RTO
TECHNICIAN	PSJ
CHECKED BY	GTF
APPROVED	RTO

DATE: 9/27/19

ALLIANCE CONSULTING ENGINEERS, INC.

Professional Engineer Seal for South Carolina, No. 35883.

SIGNATURE: [Signature]

**ALLIANCE CONSULTING ENGINEERS**

Alliance Consulting Engineers, Inc.  
 124 Verdier Blvd. - Greenville II, Suite 305 - Greenville, SC 29607  
 Phone (864) 284-1740 • Fax (864) 284-1741

PROJECT: CIVIL DESIGN PLANS FOR THE GREENPONT LANDFILL ALONG HAMLIN ROAD LOCATED IN ANDERSON COUNTY, SOUTH CAROLINA.

SCALE: AS SHOWN

DATE: JUNE 2019

SHEET: C-53

- REFERENCES:
- REFERENCE IS MADE TO TOPOGRAPHIC SURVEY PROVIDED BY F&S SURVEYORS, ENGINEERS, & PLANNERS, INC. DATED FEBRUARY 8, 2017.
  - REFERENCE IS MADE TO LIDAR TOPOGRAPHICAL DATA PROVIDED BY ANDERSON COUNTY, SOUTH CAROLINA.
  - REFERENCE IS MADE TO A WETLAND DELINEATION PERFORMED BY F&S SURVEYORS AND ENGINEERS & PLANNERS INC. DATED JANUARY 12, 2017.
  - REFERENCE IS MADE TO A GROUNDWATER MONITORING REPORT PROVIDED BY BUNNELL-LAMMONS ENGINEERING, INC. DATED MAY 16, 2019.

FILE NAME:	E16227-PLANS
REFERENCE FILE:	E16227-BASE
PROJECT NO.:	16227-0004
DWG NO.:	01.1168-D21

THIS DOCUMENT IS THE SOLE PROPERTY OF ALLIANCE CONSULTING ENGINEERS, INC. IT IS NOT TO BE REPRODUCED, COPIED OR OTHERWISE LOANED WITH OUT THE APPROVATION OF ALLIANCE CONSULTING ENGINEERS, INC. THIS DRAWING IS INTENDED SPECIFICALLY FOR THE PROJECT REFERENCED HEREIN AND IS NOT TRANSPARENT TO ANY OTHER PROJECT.

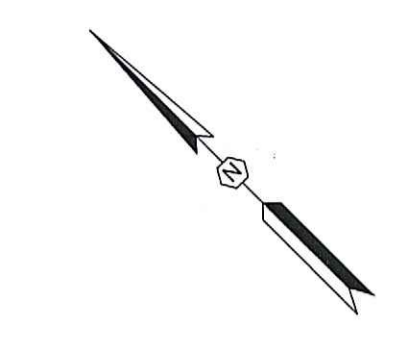
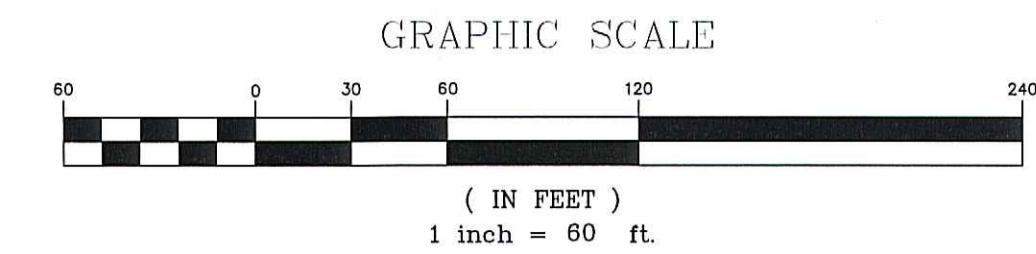

REVISION DATE	

APPROVALS

ENGINEER	RTO
DESIGNER	RTO
TECHNICIAN	PRJ
CHECKED BY	GTP
APPROVED	RTO

ALLIANCE CONSULTING ENGINEERS, INC. No. 002854

DATE: 9/27/19

REGISTERED PROFESSIONAL ENGINEER

STATE OF SOUTH CAROLINA

No. 35683

DATE: 9/27/19

**ALLIANCE CONSULTING ENGINEERS**

Alliance Consulting Engineers, Inc.  
 Alliance Consulting Engineers, Inc. Greenville, SC 29607  
 124 Verdrie Blvd. - Bonaventure II, Suite 305 - Greenville, SC 29607  
 Phone (864) 284-1740 • Fax (864) 284-1741

PROJECT: CIVIL DESIGN PLANS FOR THE CLASS II C&D GREENPOINTE LANDFILL ALONG HAMLIN ROAD LOCATED IN ANDERSON COUNTY, SOUTH CAROLINA

SCALE: AS SHOWN

DATE: JUNE 2019

PROJECT: CIVIL DESIGN PLANS FOR THE CLASS II C&D GREENPOINTE LANDFILL ALONG HAMLIN ROAD LOCATED IN ANDERSON COUNTY, SOUTH CAROLINA

SCALE: AS SHOWN

DATE: JUNE 2019

FILE NAME: E16227-PLANS

REFERENCE FILE: E16227-BASE

PROJECT NO: 16227-0004

DWG NO. 01,1168-D21

SHEET C-5.4

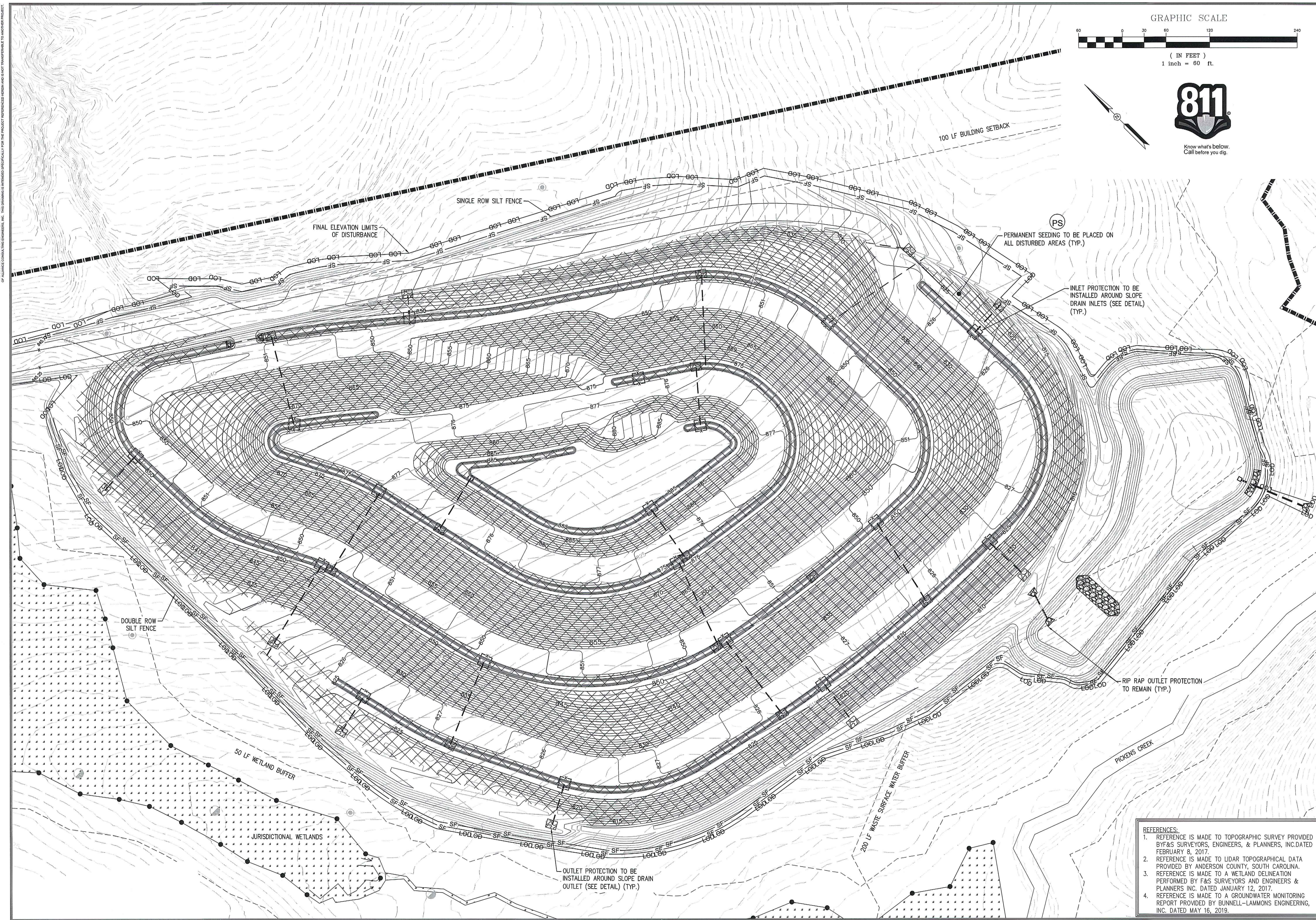

- REFERENCES:
1. REFERENCE IS MADE TO TOPOGRAPHIC SURVEY PROVIDED BY F&S SURVEYORS, ENGINEERS, & PLANNERS, INC. DATED FEBRUARY 8, 2017.
  2. REFERENCE IS MADE TO LIDAR TOPOGRAPHICAL DATA PROVIDED BY ANDERSON COUNTY, SOUTH CAROLINA.
  3. REFERENCE IS MADE TO A WETLAND DELINEATION PERFORMED BY F&S SURVEYORS AND ENGINEERS & PLANNERS INC. DATED JANUARY 12, 2017.
  4. REFERENCE IS MADE TO A GROUNDWATER MONITORING REPORT PROVIDED BY BUNNELL-LAMMONS ENGINEERING, INC. DATED MAY 16, 2019.

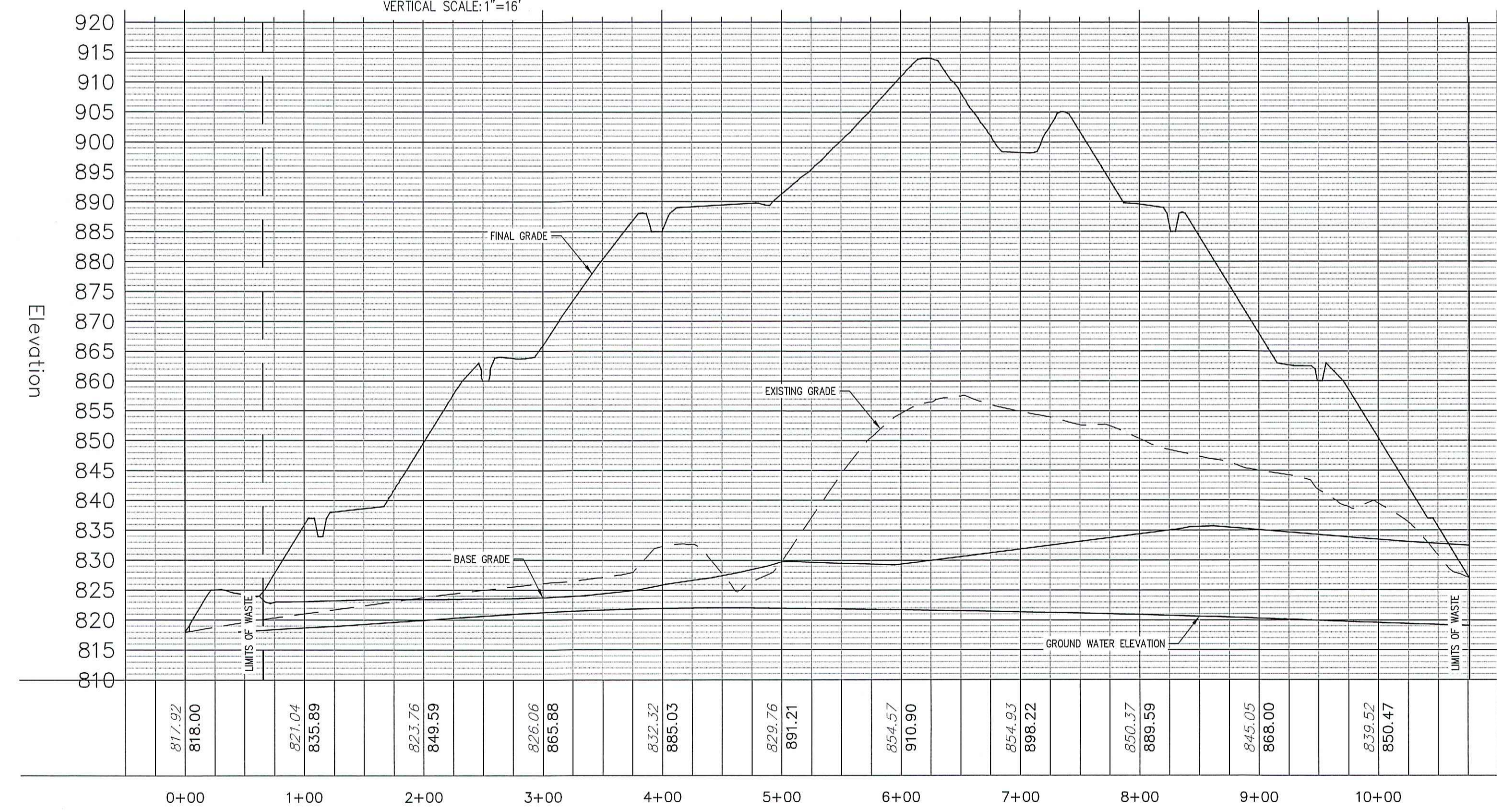
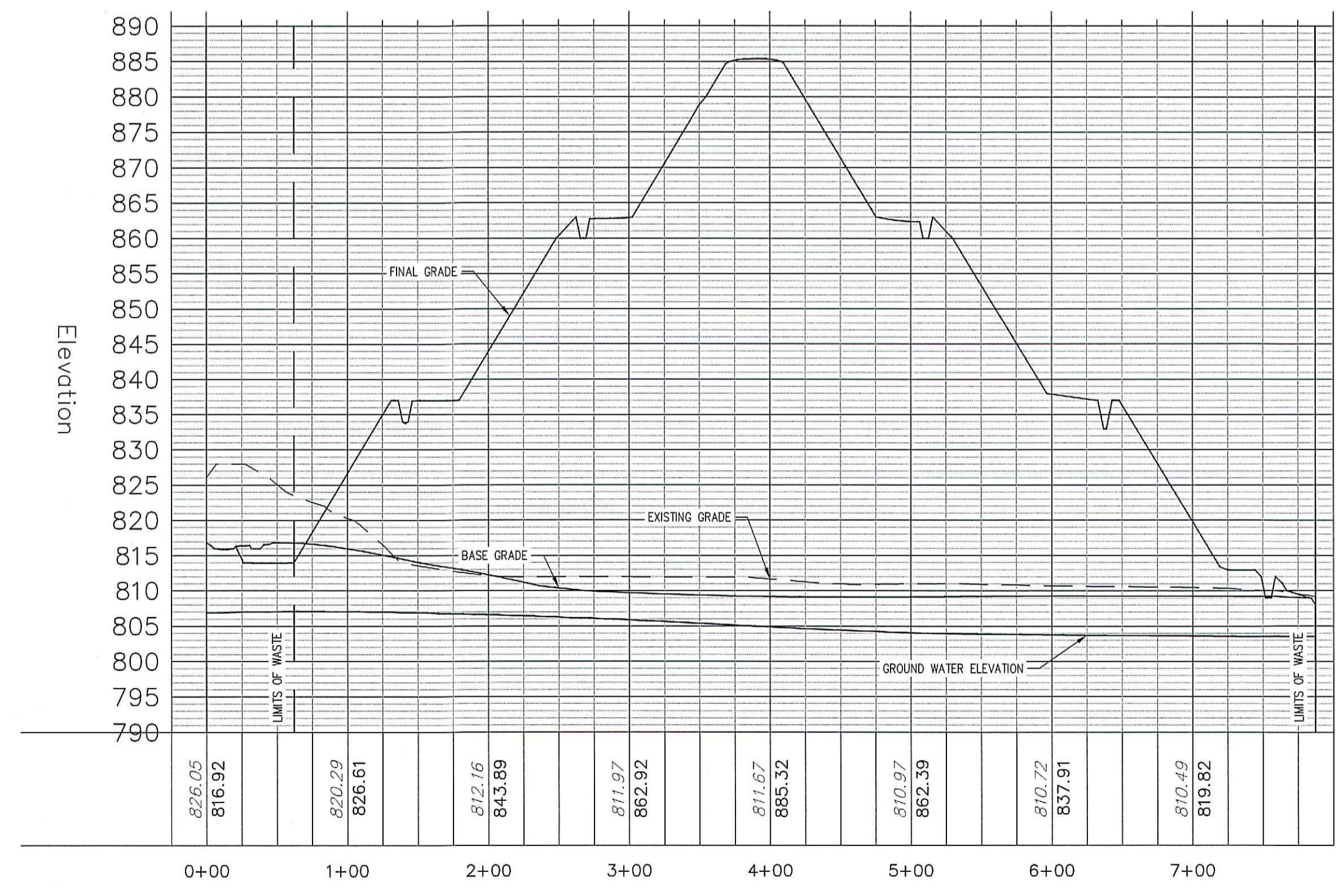
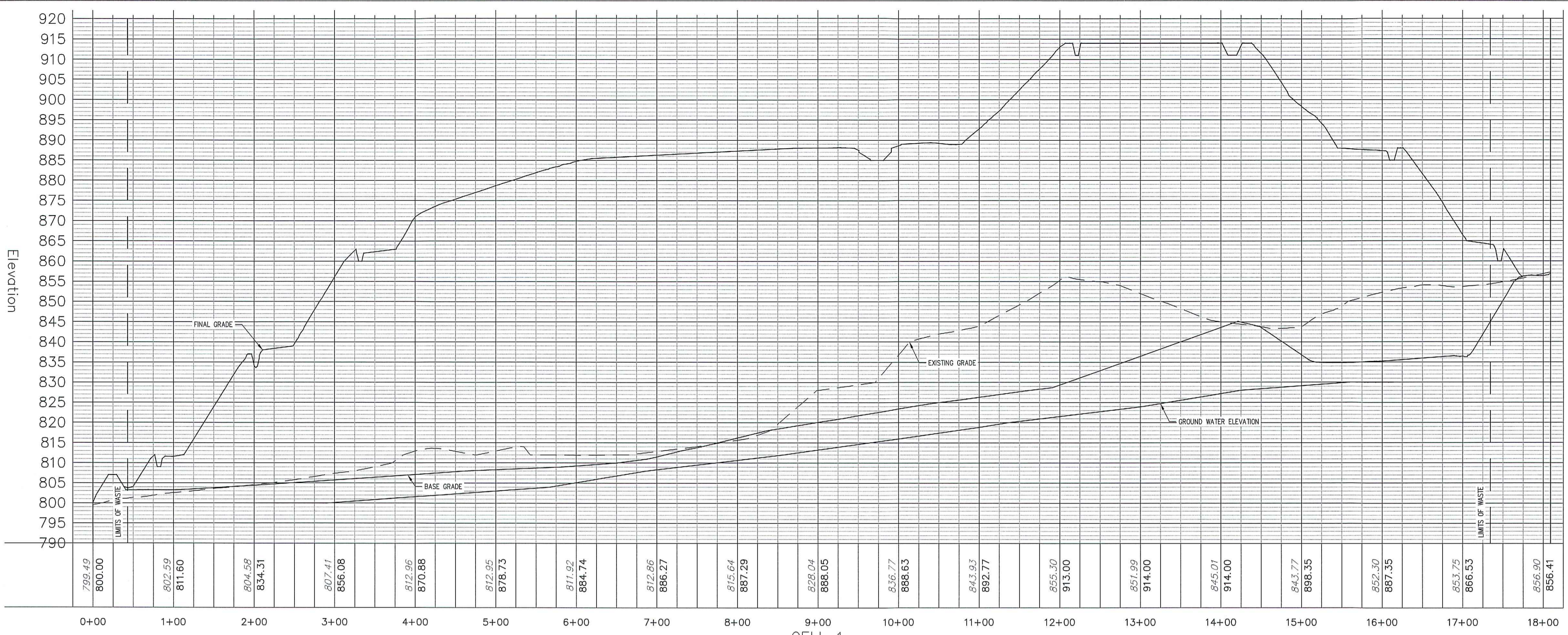
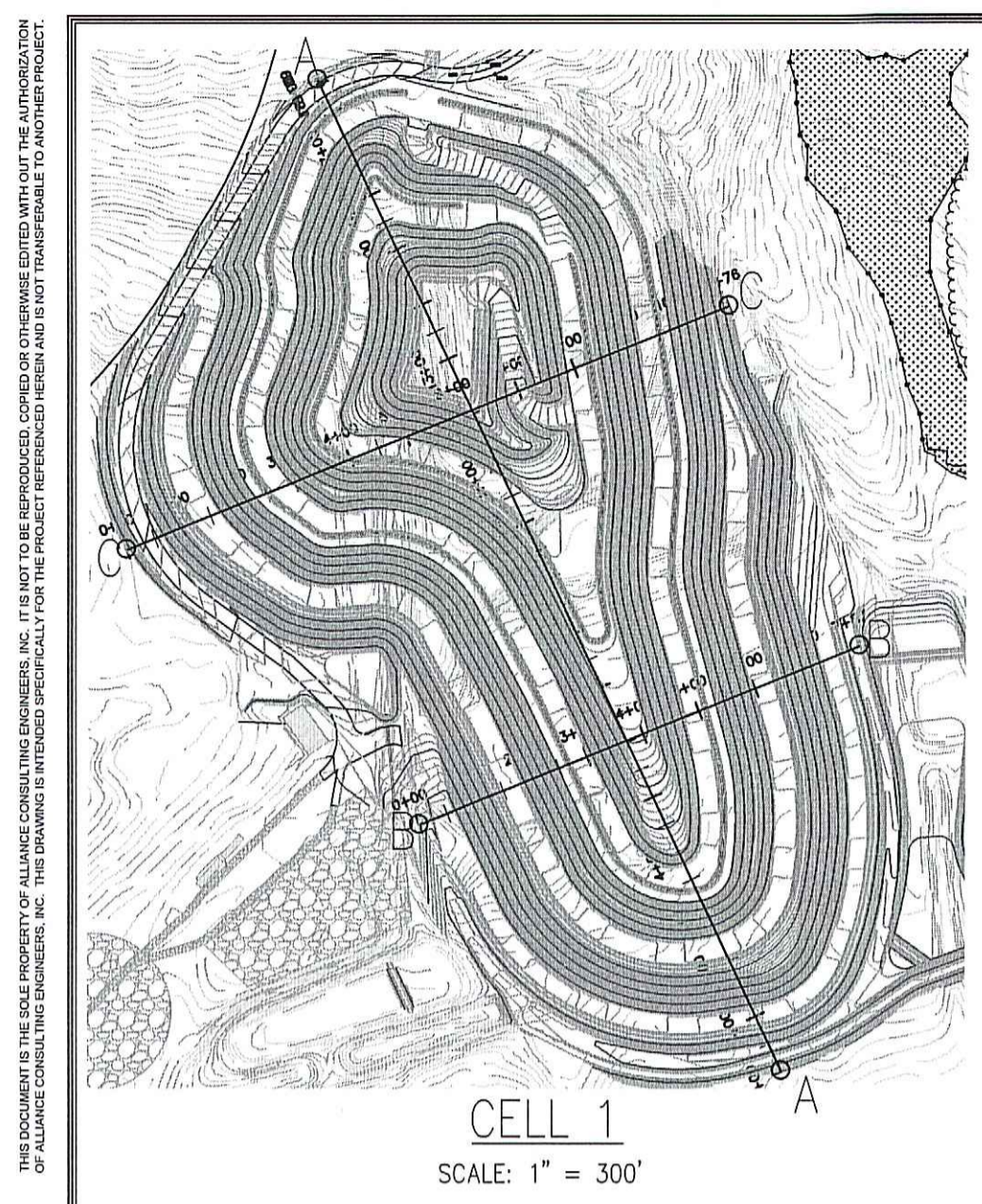

REVISION DATE

APPROVALS	ENGINEER	DESIGNER	TECHNICAL	CHECKED BY	APPROVED
	RTO	RTO	PRJ	GTF	RTO

ALLIANCE CONSULTING ENGINEERS, Inc.  
124 Verdrie Blvd. - Bonaventure II, Suite 505 - Greenville, SC 29607  
Phone: (864) 284-1740 • Fax: (864) 284-1741

DATE: 9/27/19

SCALE: AS SHOWN

CROSS SECTION - CELL 1

PROJECT: CIVIL DESIGN PLANS FOR THE CLASS II C&D GREENPOINTE LANDFILL ALONG HAMLIN ROAD LOCATED IN ANDERSON COUNTY, SOUTH CAROLINA

FILE NAME: E16227-PLANS  
REFERENCE FILE: E16227-BASE  
PROJECT NO.: 16227-0004

SHEET C-6.0

DWG NO. 01.1168-D21

THIS DOCUMENT IS THE SOLE PROPERTY OF ALLIANCE CONSULTING ENGINEERS, INC. IT IS NOT TO BE REPRODUCED, COPIED, OR TRANSMITTED IN ANY FORM OR BY ANY MEANS, ELECTRONIC OR MECHANICAL, INCLUDING PHOTOCOPYING, RECORDING, OR BY ANY INFORMATION STORAGE AND RETRIEVAL SYSTEM.

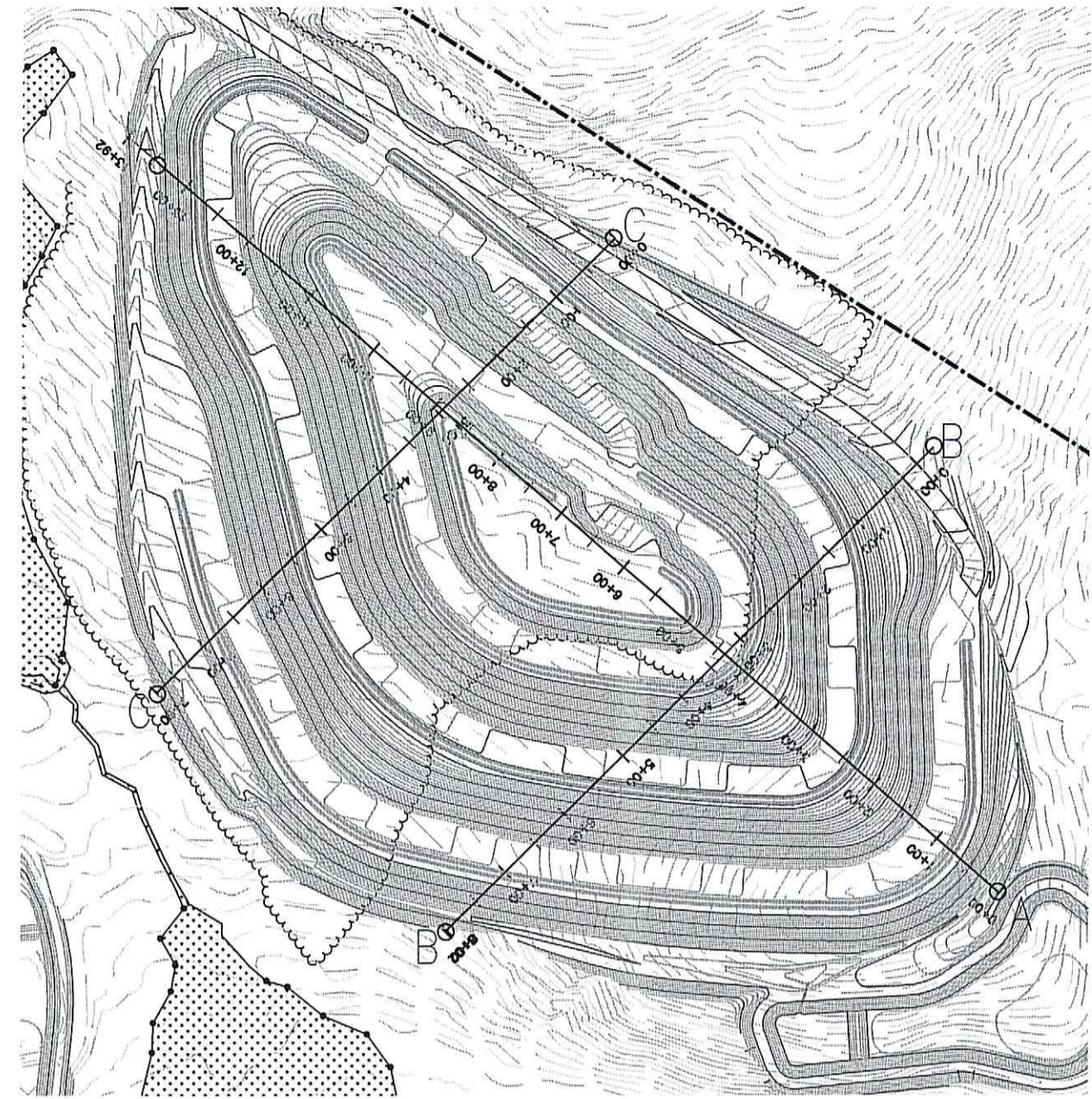

**CELL 2**  
 SCALE: 1" = 200'

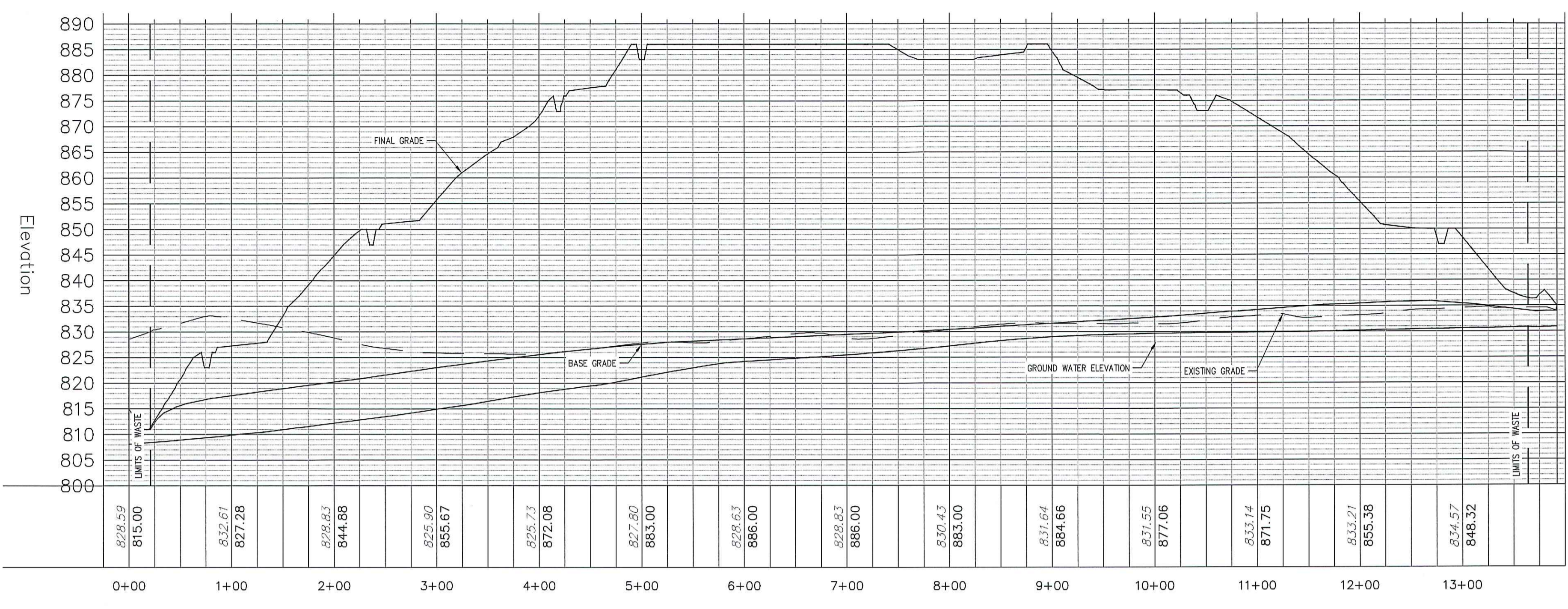

**CELL 2**  
**SECTION A-A**  
 HORIZONTAL SCALE: 1"=80'  
 VERTICAL SCALE: 1"=16'

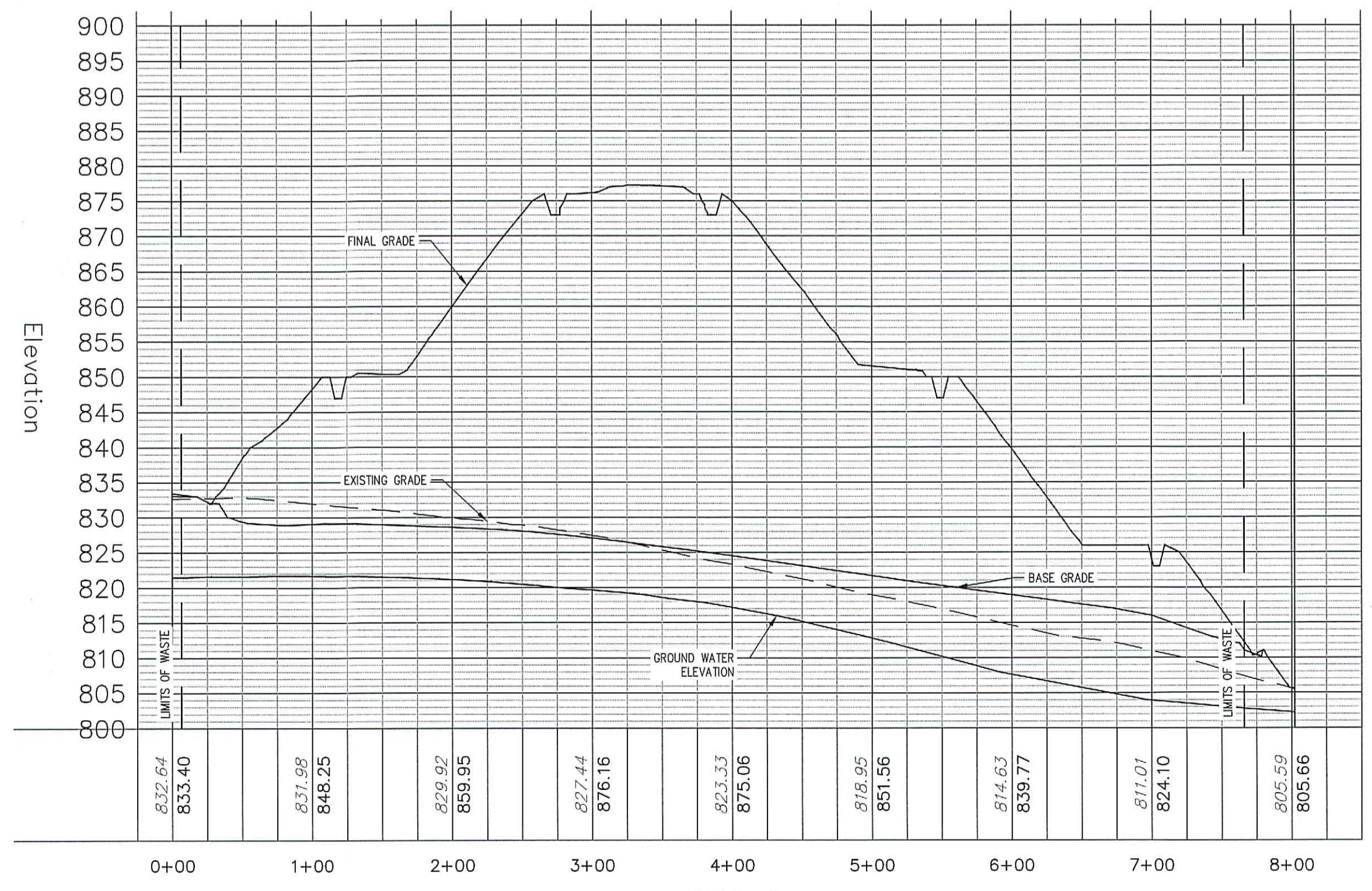

**CELL 2**  
**SECTION B-B**  
 HORIZONTAL SCALE: 1"=80'  
 VERTICAL SCALE: 1"=16'

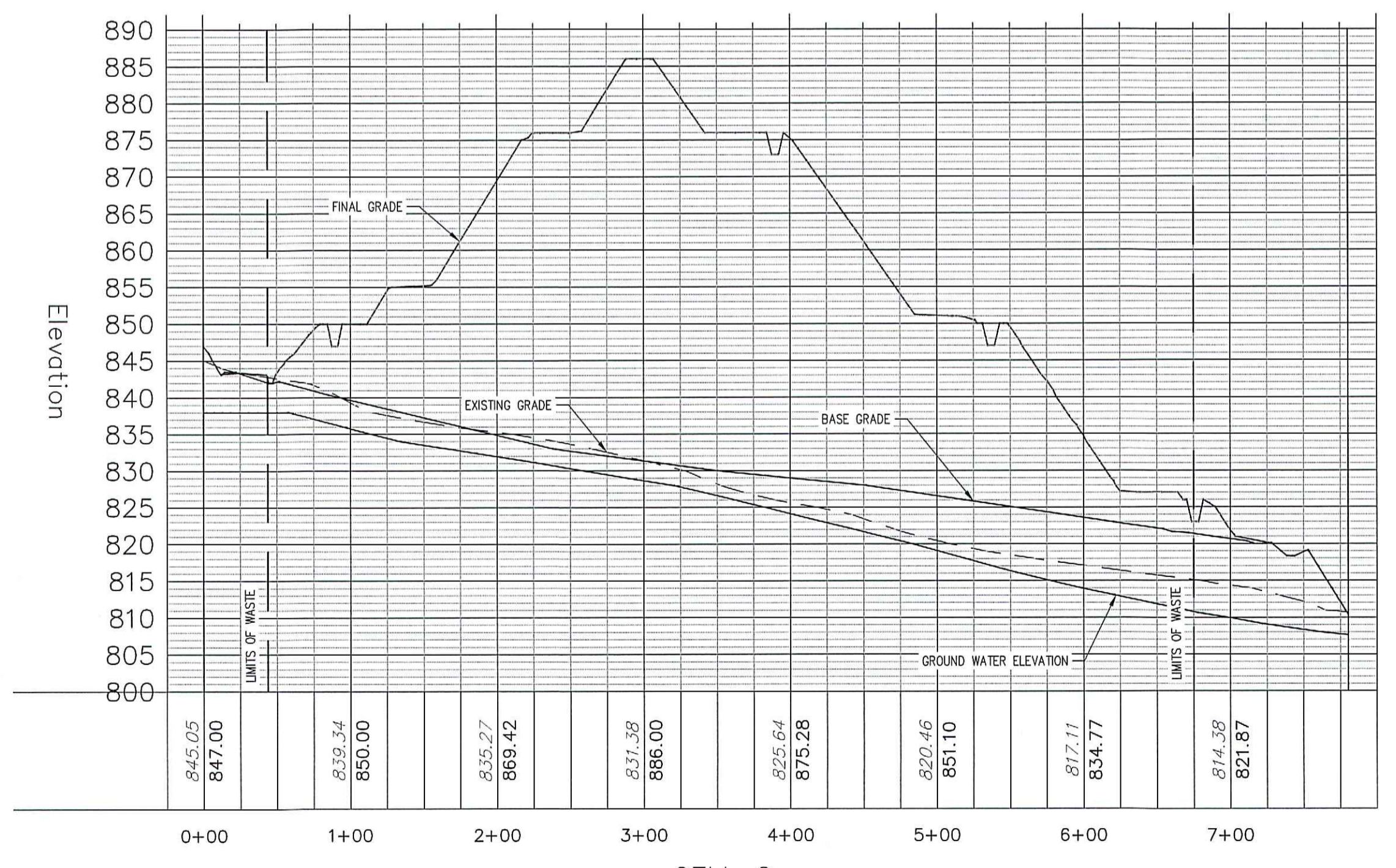

**CELL 2**  
**SECTION C-C**  
 HORIZONTAL SCALE: 1"=80'  
 VERTICAL SCALE: 1"=16'

APPROVALS	REVISION	DATE
ENGINEER		
DESIGNER		
TECHNICIAN		
CHECKED BY		
APPROVED		

ALLIANCE CONSULTING ENGINEERS, INC.  
 PROFESSIONAL ENGINEERING  
 No. 002854  
 DATE: 6/17/19

SOUTH CAROLINA PROFESSIONAL ENGINEER  
 No. 35683  
 SIGNATURE: [Signature]

**ALLIANCE CONSULTING ENGINEERS, Inc.**  
 Alliance Consulting Engineers, Inc.  
 124 Verdine Blvd. - Bonaventure II, Suite 505 - Greenville, SC 29607  
 Phone (864) 284-1746 • Fax (864) 284-1741

PROJECT: CIVIL DESIGN PLANS FOR THE CLASS II C&D GREENPOINTE LANDFILL ALONG HAMLIN ROAD LOCATED IN ANDERSON COUNTY, SOUTH CAROLINA  
 SHEET: CROSS SECTION - CELL 2  
 DATE: JUNE 2019  
 SCALE: AS SHOWN

FILE NAME: E16227-PLANS  
 REFERENCE FILE: E16227-BASE  
 PROJECT NO. 16227-0004  
 SHEET: C-61

DWG NO. 01.1168-D21





# PIPE SLOPE DRAIN

## WHEN AND WHERE TO USE IT

PIPE SLOPE DRAINS ARE USED WHEN IT IS NECESSARY FOR WATER TO FLOW DOWN A SLOPE WITHOUT CAUSING EROSION, ESPECIALLY BEFORE A SLOPE HAS BEEN STABILIZED OR BEFORE PERMANENT DRAINAGE STRUCTURES ARE INSTALLED.

## INSTALLATION:

TYPICAL PIPE SLOPE DRAINS ARE MADE OF NON-PERFORATED CORRUGATED PLASTIC PIPE.

SLOPE DRAIN SECTIONS SHOULD BE SECURELY FASTENED TOGETHER, HAVE GASKET WATERTIGHT FITTINGS, AND BE SECURELY ANCHORED INTO THE SOIL.

DIVERSION BERMS OR DIKES SHOULD DIRECT RUNOFF TO SLOPE DRAINS. THE MINIMUM DEPTH OF THESE DIKES OR BERMS SHOULD BE 1.5 FEET. THE HEIGHT OF THE BERM AROUND THE PIPE INLET SHOULD BE A MINIMUM OF 1.5 FEET HIGH AND AT LEAST 0.5 FEET HIGHER THAN THE TOP OF THE PIPE. THE BERM AT THE PIPE INLET SHALL BE COMPACTED AROUND THE PIPE. THE AREA AROUND THE INLET SHALL BE PROPERLY STABILIZED WITH ECBS, TRMS, RIPRAP OR OTHER APPLICABLE STABILIZATION TECHNIQUES.

THE AREA BELOW THE OUTLET MUST BE PROPERLY STABILIZED WITH ECBS, TRMS, RIPRAP OR OTHER APPLICABLE STABILIZATION TECHNIQUE.

IF THE PIPE SLOPE DRAIN IS CONVEYING SEDIMENT-LADEN WATER, DIRECT ALL FLOWS INTO THE SEDIMENT TRAPPING FACILITY.

PERMANENT SLOPE DRAINS SHOULD BE BURIED BENEATH THE SOIL SURFACE A MINIMUM 1.5 FEET.

## INSPECTION AND MAINTENANCE:

INSPECT PIPE SLOPE DRAIN INLET AND OUTLET POINTS EVERY SEVEN (7) CALENDAR DAYS AND WITHIN 24-HOURS AFTER EACH RAINFALL EVENT THAT PRODUCES 1/2-INCHES OR MORE OF PRECIPITATION.

THE INLET SHOULD BE FREE FROM UNDERCUTTING, AND NO WATER SHOULD BE GOING AROUND THE POINT OF ENTRY. IF THERE ARE PROBLEMS, THE HEADWALL SHOULD BE REINFORCED WITH COMPACTED EARTH OR SANDBAGS. THE OUTLET POINT SHOULD BE FREE OF EROSION AND INSTALLED WITH APPROPRIATE OUTLET PROTECTION.

ALL TEMPORARY PIPE SLOPE DRAINS SHOULD BE REMOVED WITHIN 30 DAYS AFTER FINAL SITE STABILIZATION IS ACHIEVED OR AFTER THE TEMPORARY BMP IS NO LONGER NEEDED. DISTURBED SOIL AREAS RESULTING FROM REMOVAL SHOULD BE PERMANENTLY STABILIZED.

## PIPE SLOPE DRAIN

(SCDHEC DETAIL RC-01, pg 2 of 2)

## PERMANENT GRASSING SPECIFICATIONS: (PG)

- ALL SEED MIXTURES FOR THE VARIOUS SEEDING SCHEDULES SHALL BE WEIGHED AND MIXED TO THE PROPER PROPORTIONS IN THE PRESENCE OF THE OWNER OR THE OWNER'S REPRESENTATIVE.
- MAT ALL GRASSES, SWALES, WATERWAYS, AND EMBANKMENTS FROM TOP OF BANK TO BOTTOM OF BANK ON ALL BANK SLOPES LESS THAN 3:1.

PERMANENT SEEDING		
Maintained Turf (High Profile Lawn/Landscaped Areas)	Variety	Application Rate
April 1 - September 15	Bermuda Triangle Blend by Pennington Seed, Inc.	125 LBS/ACRE
Slopes 4H:1V or Greater		
April 1 - September 15	Slopemaster Spring/Summer Mix by Pennington Seeding, Inc.	75 LBS/ACRE
Slopemaster Spring/Summer Mix Composition:		
25% Hulled Sahara Bermudagrass		
25% Unhulled Sahara Bermudagrass		
25% Pensacola Bahiagrass		
10% Durana White Clover		
10% Brown Top Millet		
5% Weeping Lovegrass		
September 15 - March 31	Slopemaster Fall/Winter Mix by Pennington Seed, Inc.	100 LBS/ACRE
Slopemaster Fall/Winter Mix Composition:		
25% Unhulled Sahara Bermudagrass		
20% Graystone Tall Fescue		
10% Durana White Clover		
10% Rye Grain		
5% Weeping Lovegrass		
Slope 4H:1V or Less		
April 1 - September 15	Hulled Sahara Bermudagrass	75 LBS/ACRE
September 15 - March 31	Unhulled Sahara Bermudagrass	100 LBS/ACRE

\*Cont'd - Pennington Seed, Inc. - 1239 Eden Street, Columbia, SC 29201

## NOTES: INSPECTION AND MAINTENANCE

CHECK DAMS SHOULD BE INSPECTED EVERY 7 CALENDAR DAYS AND WITHIN 24-HOURS AFTER EACH STORM THAT PRODUCES 1/2-INCHES OR MORE OF RAIN TO ENSURE CONTINUED EFFECTIVENESS. LARGE DEBRIS, TRASH, AND LEAVES SHOULD BE REMOVED. IF EROSION CAUSES THE EDGES TO FALL TO A HEIGHT EQUAL TO OR BELOW THE HEIGHT OF THE CENTER, REPAIRS SHOULD BE MADE IMMEDIATELY. REMOVE ACCUMULATED SEDIMENT FROM THE UPSTREAM SIDE OF THE SEDIMENT TUBE WHEN THE SEDIMENT HAS REACHED A HEIGHT OF APPROXIMATELY ONE-THIRD OF THE EXPOSED HEIGHT OF THE TUBE (MEASURED AT THE CENTER). ACCUMULATED SEDIMENT SHOULD BE REMOVED PRIOR TO REMOVING SEDIMENT TUBES. SEDIMENT TUBE REMOVAL SHOULD BE COMPLETED ONLY AFTER THE CONTRIBUTING DRAINAGE AREA HAS BEEN COMPLETELY STABILIZED. PERMANENT VEGETATION SHOULD REPLACE AREAS FROM WHICH GRAVEL, STONE, SEDIMENT TUBES, OR OTHER MATERIALS HAVE BEEN REMOVED.

## SEDIMENT TUBE SPACING

SLOPE	MAXIMUM SEDIMENT TUB SPACING
LESS THAN 2%	150-FOOT
2%	100-FOOT
3%	75-FOOT
4%	50-FOOT
5%	40-FOOT
6%	30-FOOT
GREATER THAN 6%	25-FOOT

## SEDIMENT TUBE DETAIL

N.T.S.

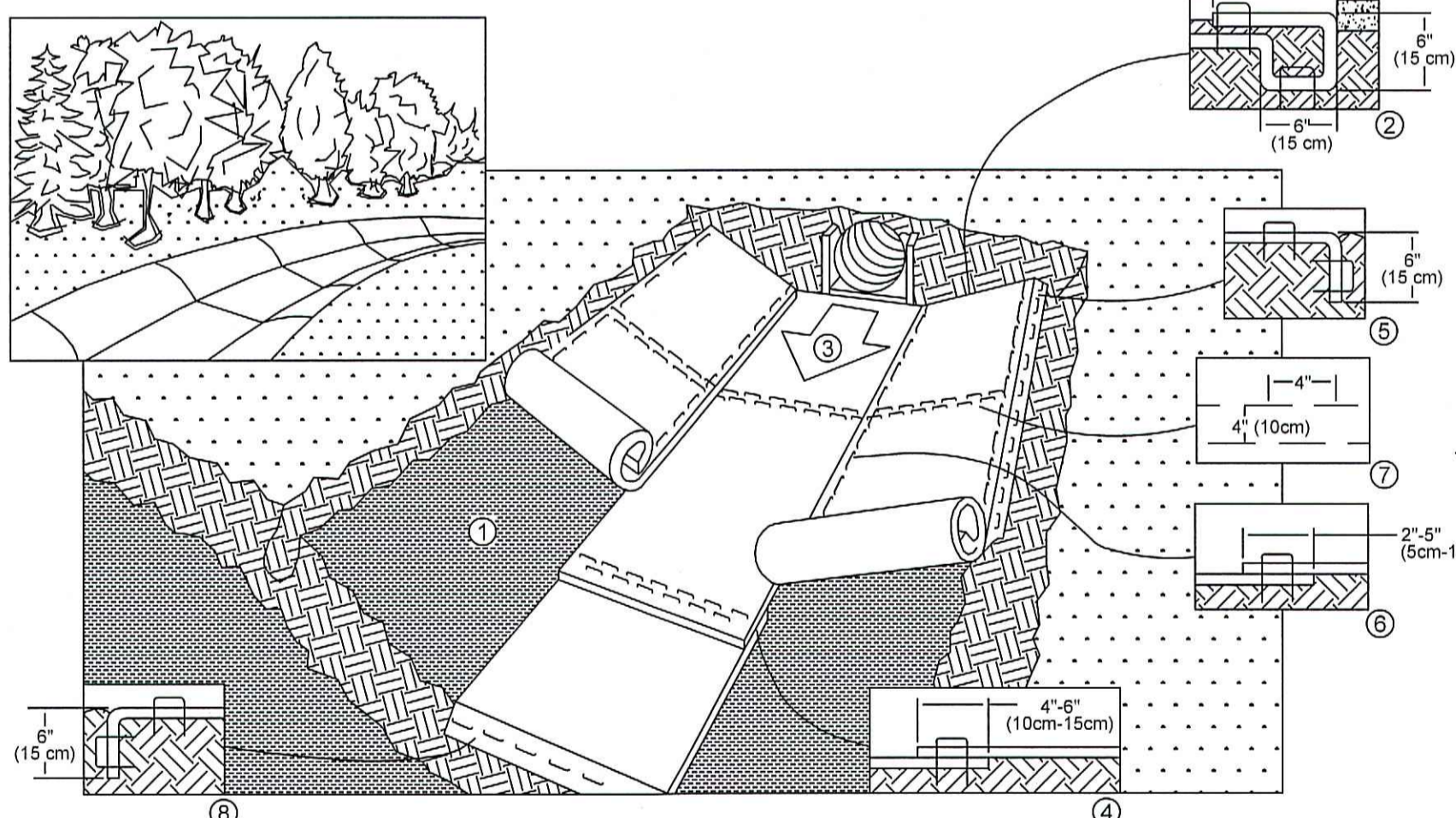

## CHANNEL INSTALLATION DETAIL

(PROVIDED BY NORTH AMERICAN GREEN REVISED JAN. 04')

N.T.S.

GEOTEXTILE EROSION CONTROL BLANKET SHALL BE SC150 AS MANUFACTURED BY NORTH AMERICAN GREEN OR EQUIVALENT

GEOTEXTILE EROSION CONTROL BLANKET SHALL BE INSTALLED PER THE MANUFACTURER'S RECOMMENDATION (TYP.)

DEFINITION: A PROTECTIVE COVERING (BLANKET) OR SOIL STABILIZATION MAT USED TO ESTABLISH EXIT VEGETATION ON STEEP SLOPES, CHANNELS, OR SHORELINES.

PURPOSE: TO PROVIDE A MICROCLIMATE WHICH PROTECTS YOUNG VEGETATION AND PROMOTES ITS ESTABLISHMENT. TO REINFORCE THE TURF TO RESIST FORCES OF EROSION DURING STORM EVENTS.

CONDITIONS: MATTING AND BLANKETS CAN BE APPLIED ON STEEP SLOPES WHERE EROSION HAZARD IS HIGH AND PLANTING IS LIKELY TO BE SLOW IN PROVIDING ADEQUATE PROTECTIVE COVER. CONCENTRATED FLOW AREAS, ALL SLOPES STEEPER THAN 2.5:1 AND WITH A HEIGHT OF TEN FEET OR GREATER, AND CUTS AND FILLS WITHIN STREAM BUFFERS, SHALL BE STABILIZED WITH THE APPROPRIATE EROSION CONTROL MATTING OR BLANKETS. ON STREAMBANKS OR TIDAL SHORELINES WHERE MOVING WATER IS PRESENT, MATTING CAN PREVENT NEW PLANTINGS FROM BEING WASHED AWAY.

MATERIALS: GEOTEXTILE EROSION CONTROL BLANKET SHALL BE SC150 AS MANUFACTURED BY NORTH AMERICAN GREEN OR EQUIVALENT.

## EROSION CONTROL MATTING DETAIL

N.T.S.

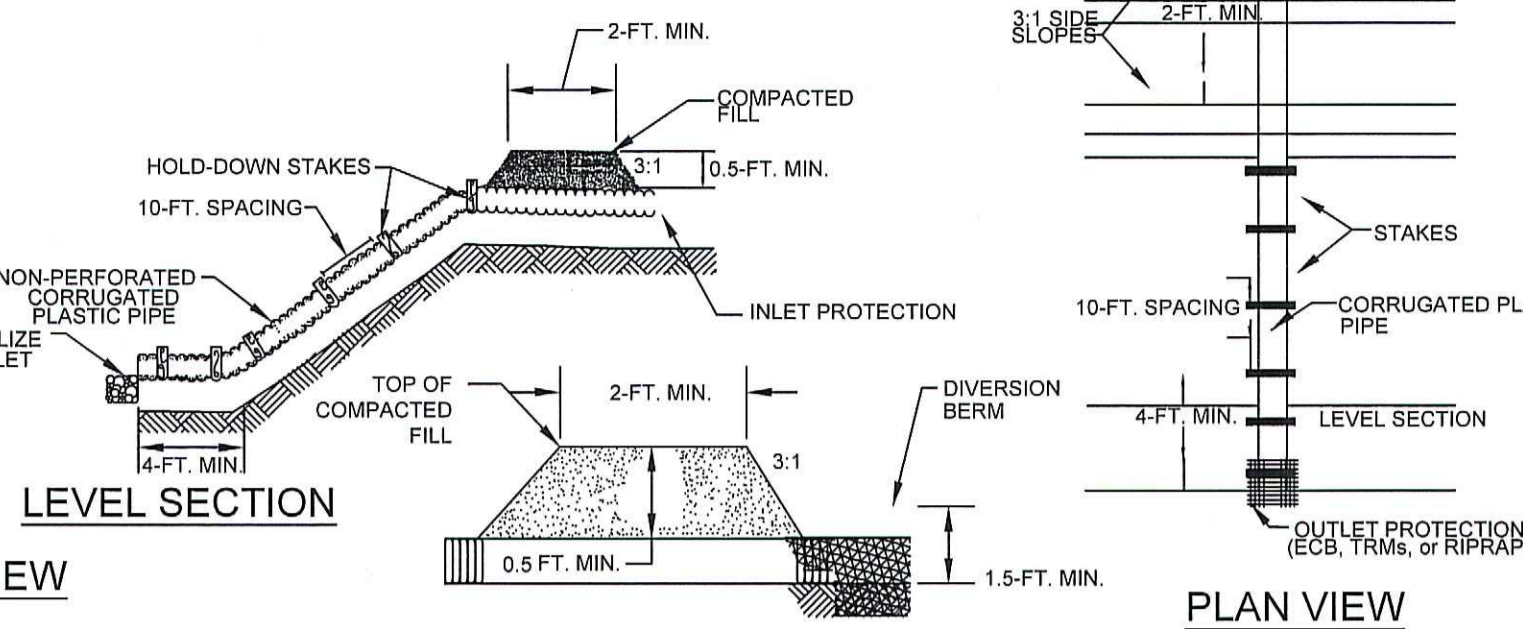

## TYPICAL PIPE SLOPE DRAIN LAYOUT

INSTALLATION: TYPICAL PIPE SLOPE DRAINS ARE MADE OF NON-PERFORATED CORRUGATED PLASTIC PIPE. SLOPE DRAIN SECTIONS SHOULD BE SECURELY FASTENED TOGETHER, HAVE GASKET WATERTIGHT FITTINGS, AND BE SECURELY ANCHORED INTO THE SOIL. DIVERSION BERMS OR DIKES SHOULD DIRECT RUNOFF TO SLOPE DRAINS. THE MINIMUM DEPTH OF THESE DIKES OR BERMS SHOULD BE 1.5 FEET. THE HEIGHT OF THE BERM AROUND THE PIPE INLET SHOULD BE A MINIMUM OF 1.5 FEET HIGH AND AT LEAST 0.5 FEET HIGHER THAN THE TOP OF THE PIPE. THE BERM AT THE PIPE INLET SHALL BE COMPACTED AROUND THE PIPE. THE AREA AROUND THE INLET SHALL BE PROPERLY STABILIZED WITH ECBS, TRMS, RIPRAP OR OTHER APPLICABLE STABILIZATION TECHNIQUE. IF THE PIPE SLOPE DRAIN IS CONVEYING SEDIMENT-LADEN WATER, DIRECT ALL FLOWS INTO THE SEDIMENT TRAPPING FACILITY. PERMANENT SLOPE DRAINS SHOULD BE BURIED BENEATH THE SOIL SURFACE A MINIMUM 1.5 FEET.

INSPECTION AND MAINTENANCE: INSPECT PIPE SLOPE DRAIN INLET AND OUTLET POINTS EVERY SEVEN (7) CALENDAR DAYS AND WITHIN 24-HOURS AFTER EACH RAINFALL EVENT THAT PRODUCES 1/2-INCHES OR MORE OF PRECIPITATION. THE INLET SHOULD BE FREE FROM UNDERCUTTING, AND NO WATER SHOULD BE GOING AROUND THE POINT OF ENTRY. IF THERE ARE PROBLEMS, THE HEADWALL SHOULD BE REINFORCED WITH COMPACTED EARTH OR SANDBAGS. THE OUTLET POINT SHOULD BE FREE OF EROSION AND INSTALLED WITH APPROPRIATE OUTLET PROTECTION. ALL TEMPORARY PIPE SLOPE DRAINS SHOULD BE REMOVED WITHIN 30 DAYS AFTER FINAL SITE STABILIZATION IS ACHIEVED OR AFTER THE TEMPORARY BMP IS NO LONGER NEEDED. DISTURBED SOIL AREAS RESULTING FROM REMOVAL SHOULD BE PERMANENTLY STABILIZED.

## SLOPE DRAIN DETAIL

N.T.S.

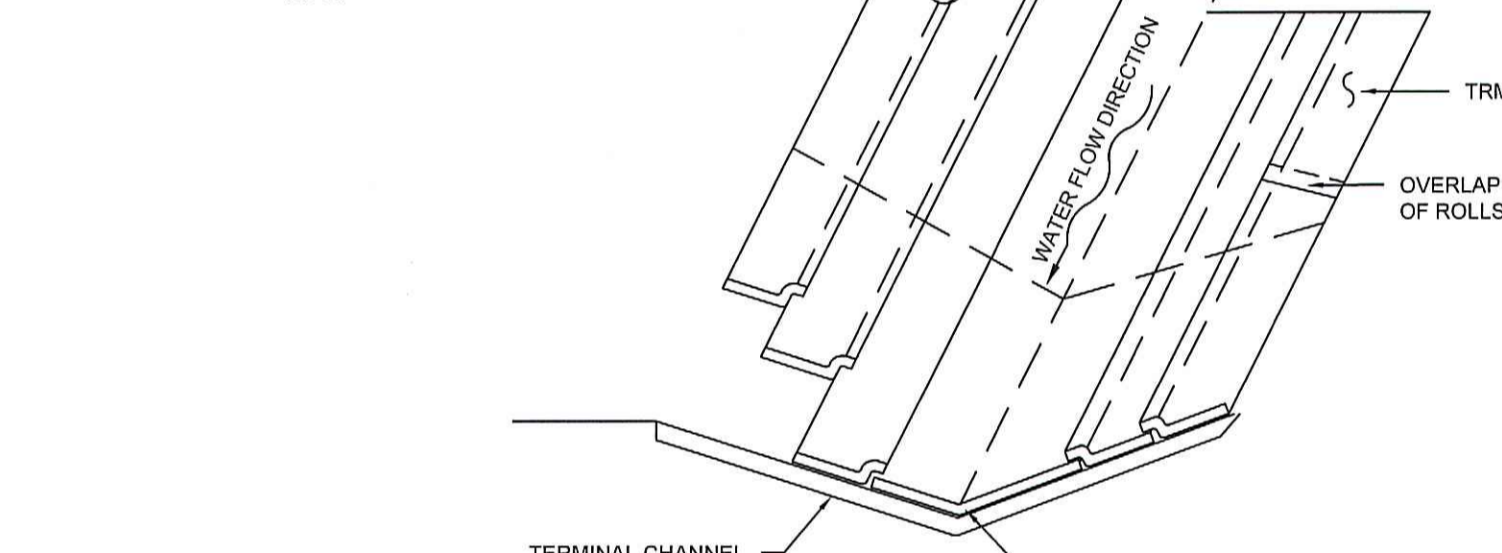

## PLUNGE POOL

N.T.S.

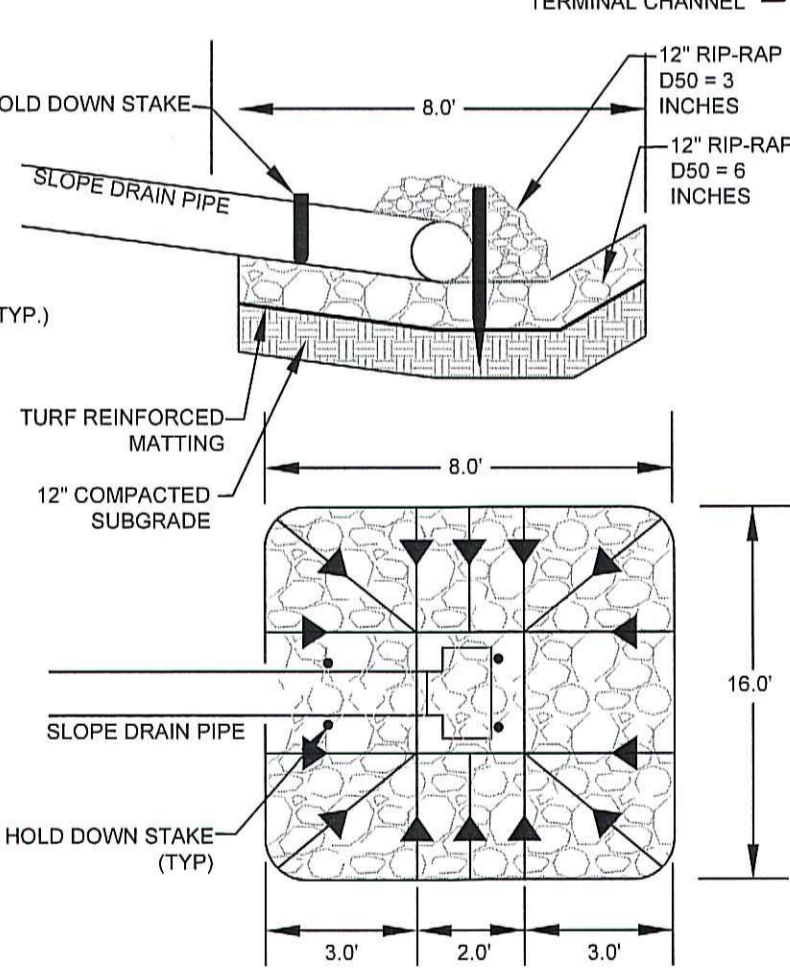

## TRM SLOPE REINFORCEMENT MATTING DETAIL

N.T.S.

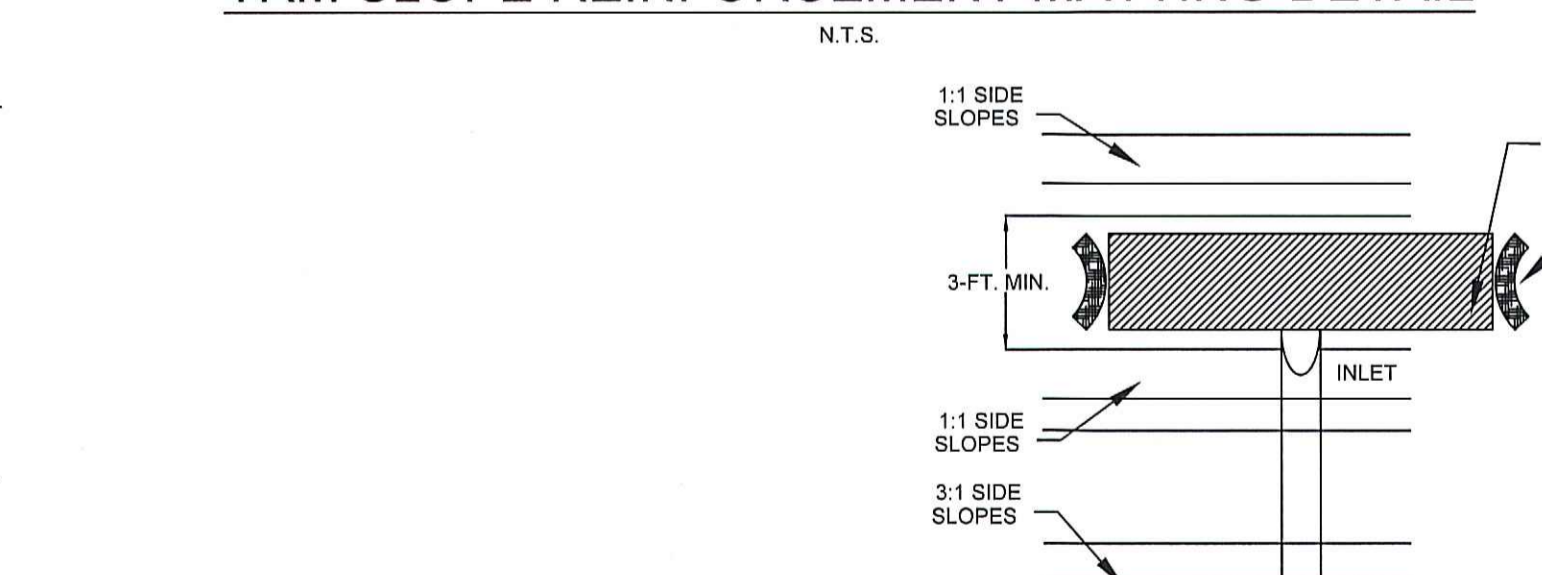

## TYPICAL SLOPE DRAIN CROSSING LIFT ACCESS ROADS

N.T.S.

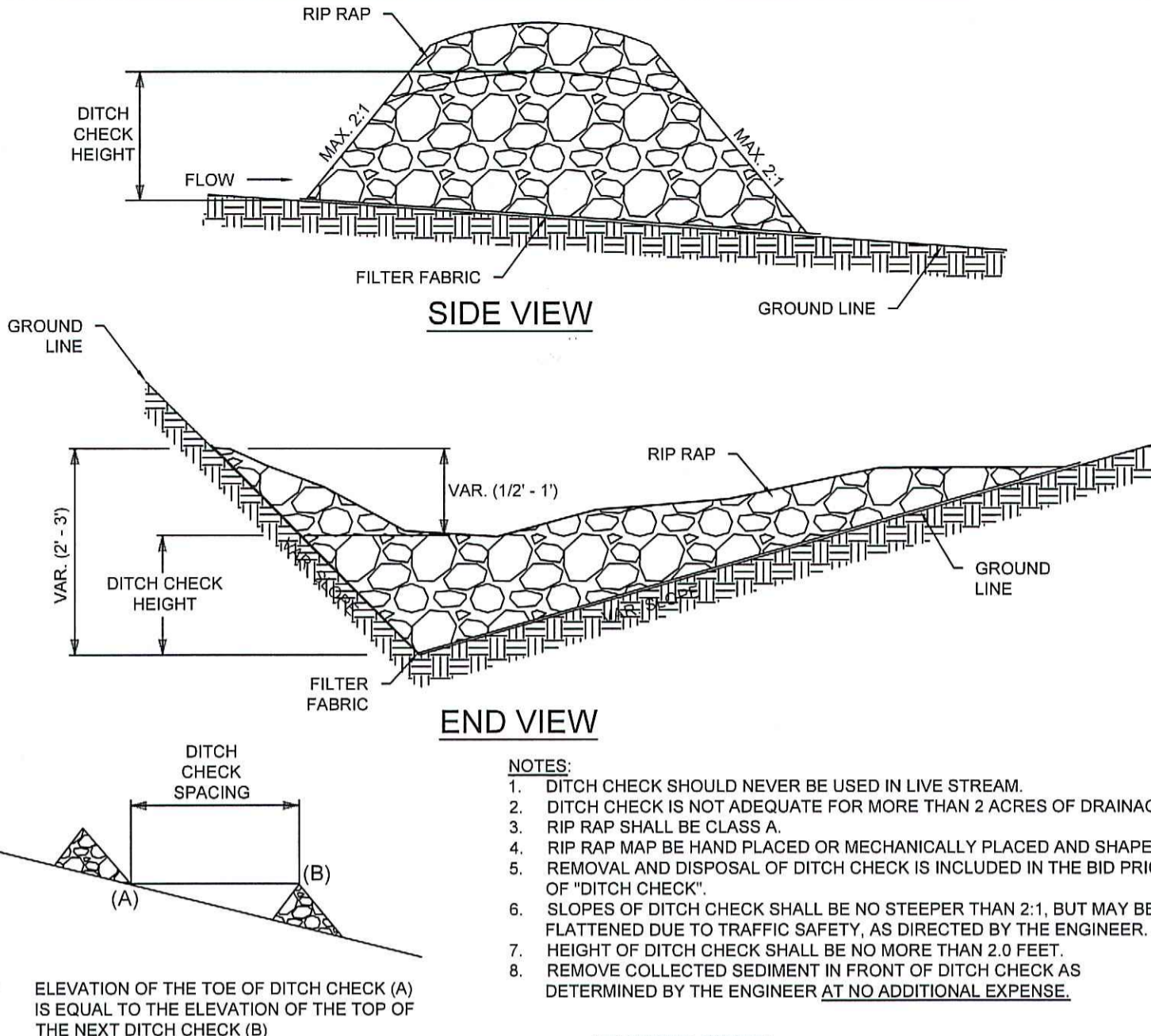
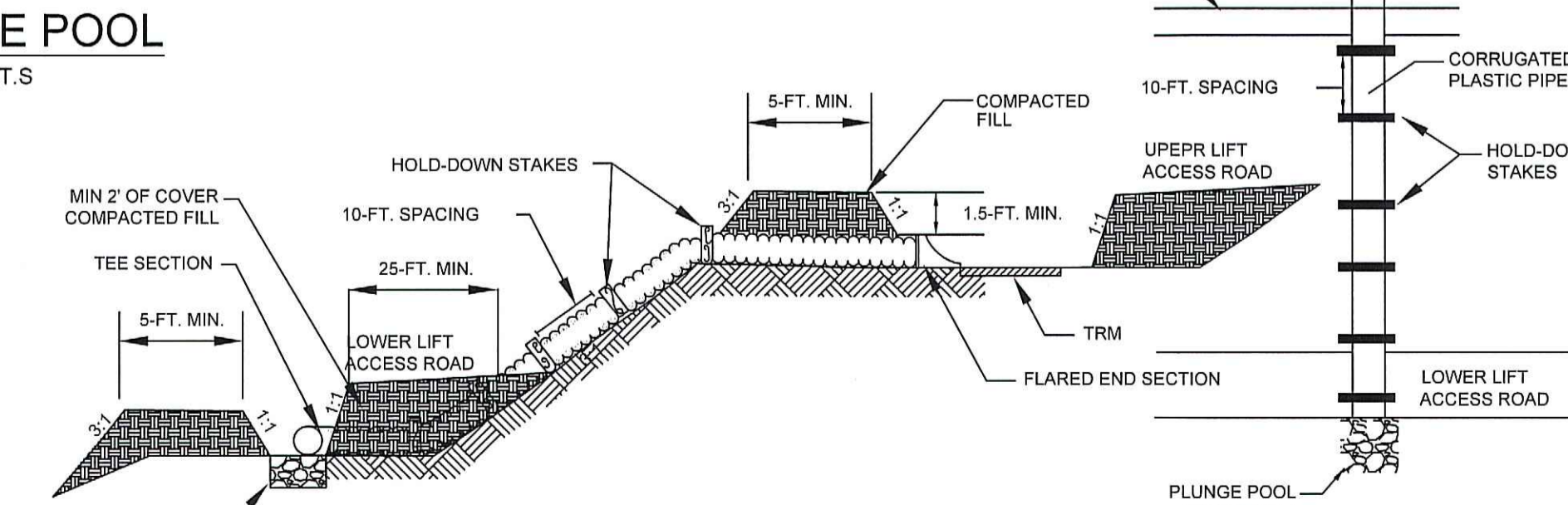

## CHECK DAMS DETAIL

N.T.S.

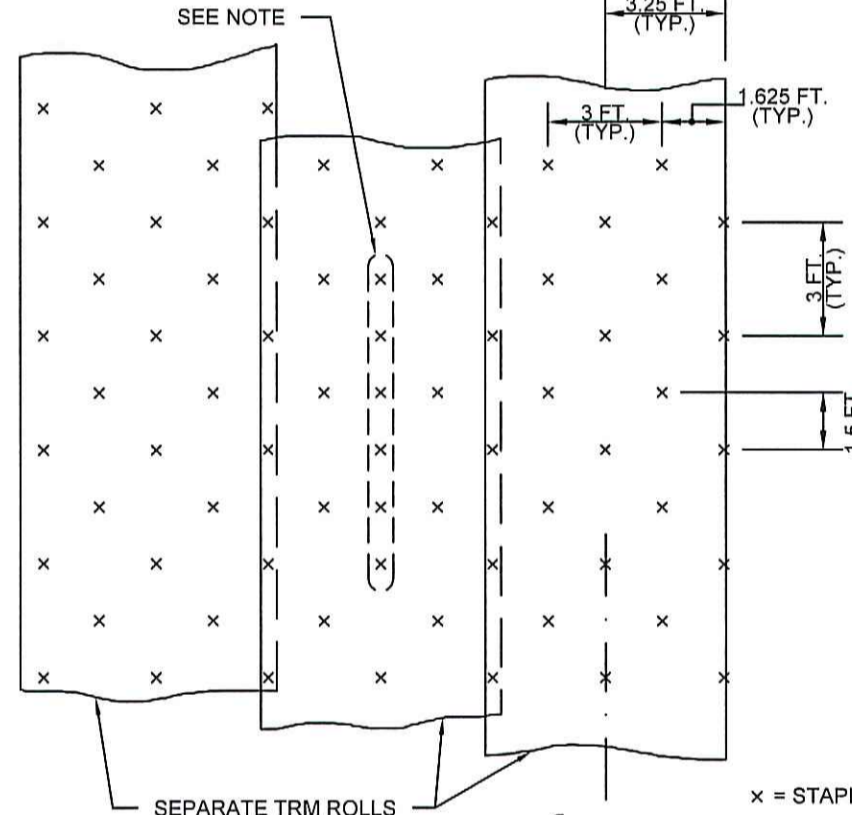

NOTE: ADDITIONAL STAPLES MIGHT BE REQUIRED AT IRREGULARITY ELEVATION CHANGES OF THE GROUND SURFACE. ALWAYS SPACE STAPLES AT 1.5 FT. INTERVALS IN CENTER OF THE DITCH (V-SHAPE) AND AT TOE OF (TRAPEZOID-SHAPE) CHANNEL. ENSURE ALL FASTENERS ARE INSTALLED TO MAKE DIRECT CONTACT WITH TRM AND SOIL.

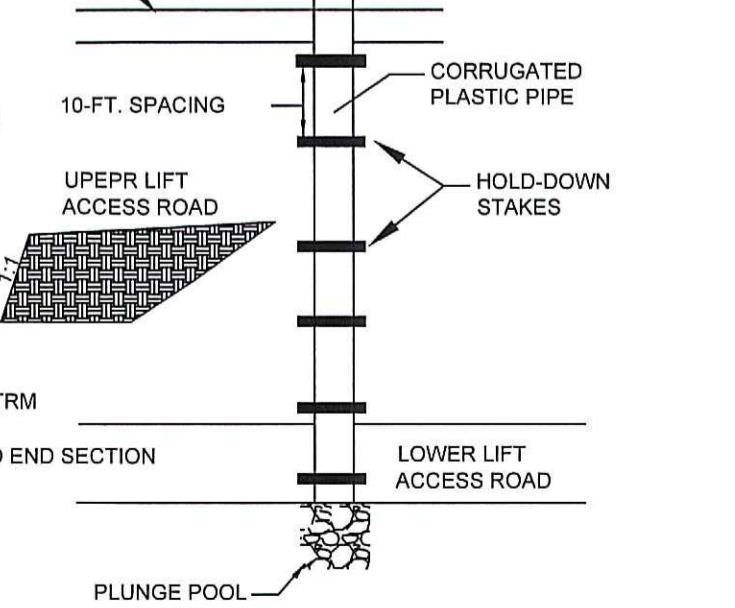
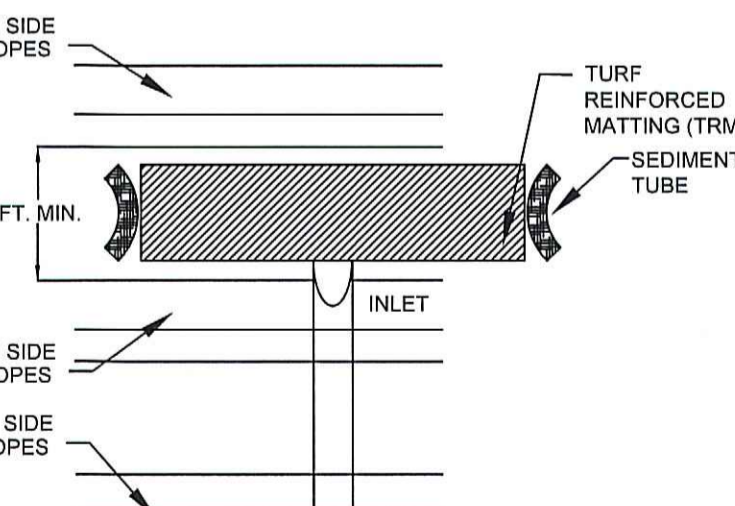

REVISION DATE	
APPROVALS	
ENGINEER	RTO
DESIGNER	RTO
TECHNICIAN	PRJ
CHECKED BY	GTF
APPROVED	RTO

DATE: 9/29/19

SCDOT  
South Carolina Department of Transportation  
DRAWING NO. 815-3

**ALLIANCE CONSULTING ENGINEERS**  
Alliance Consulting Engineers, Inc.  
124 Verdine Blvd., Bonaville, SC 29505 - Greenville, SC 29607  
Phone: (864) 294-1740 Fax: (864) 294-1741

EROSION AND SEDIMENT CONTROL DETAILS

CIVIL DESIGN PLANS FOR THE CLASS II C&D GREENPOINTE LANDFILL ALONG HAMLIN ROAD LOCATED IN ANDERSON COUNTY, SOUTH CAROLINA

FILE NAME: E16227-PLANS  
REFERENCE FILE: E16227-BASE  
PROJECT NO: 16227-0004

SHEET C-7.1

DWG NO. 01,1168-D21





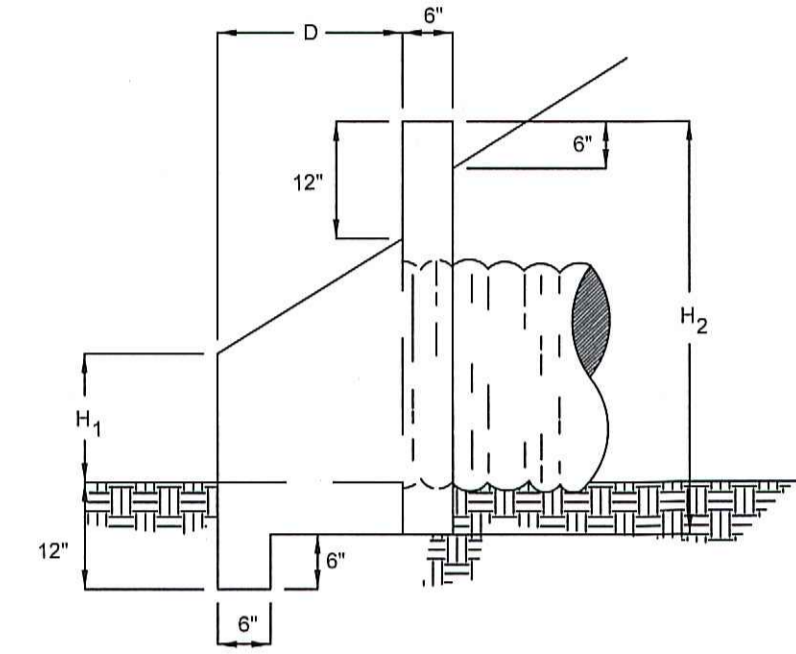

TABLE I								
HEADWALL DIMENSIONS FOR METAL PIPE *								
INSIDE DIA. OF PIPE	W <sub>1</sub>	W <sub>2</sub>	H <sub>1</sub>	H <sub>2</sub>	D	E	WT.	SQ. FT. IN BASE AREA
18"	3'-2"	4'-10"	1'-3"	3'-2"	1'-3"	1'-9"	1,550	7.34
21", 24"	3'-8"	6'-1"	1'-9"	3'-8"	1'-6"	2'-3"	2,100	9.90
30"	4'-2"	7'-2"	2'-0"	4'-2"	1'-10"	2'-9"	2,890	13.50
36"	4'-8"	8'-4"	2'-4"	4'-8"	2'-2"	3'-3"	3,700	17.65
42", 48", 54"	5'-8"	10'-10"	3'-3"	6'-8"	2'-11"	4'-3"	5,600	28.60
60"	8'-9"	13'-10"	4'-5"	8'-0"	3'-4"	7'-5"	10,070	-
72"	9'-2"	14'-2"	4'-5"	9'-0"	3'-4"	7'-10"	10,070	-

\* USE NEXT LARGER SIZE FOR CONCRETE PIPE

**NOTES:**

1. USE NEXT LARGER SIZE FOR CONCRETE PIPE
2. ALL CONCRETE SHALL BE 4000 PSI
3. REINFORCEMENT STEEL SHALL BE 1/2" DIA. OF INTERMEDIATE GRADE
4. CHAMFER ALL EXPOSED EDGES 3/4"



SIDE VIEW

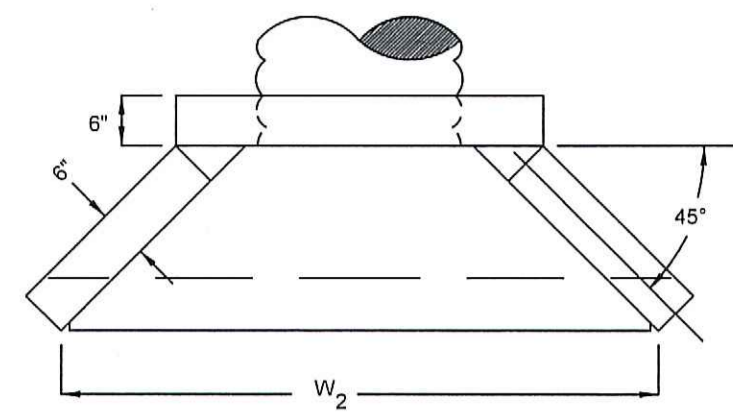

PLAN VIEW

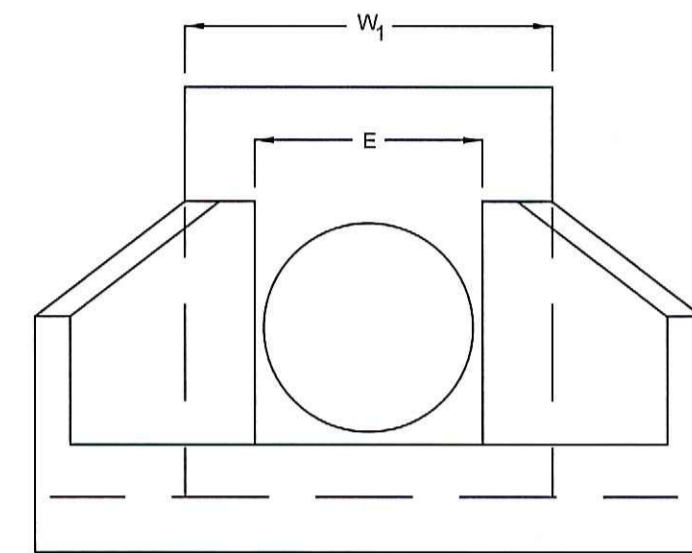

FRONT ELEVATION VIEW

**HEAD WALL DETAIL**

N.T.S.

SELECT BACKFILL COMPACTED IN MAXIMUM 6" LAYERS MEASURED LOOSE TO TOP OF TRENCH. COMPACT TO 95% OF OPTIMUM DENSITY IN ACCORDANCE WITH ASTM D698 OR 92% OF OPTIMUM DENSITY IN ACCORDANCE WITH ASTM D1557.

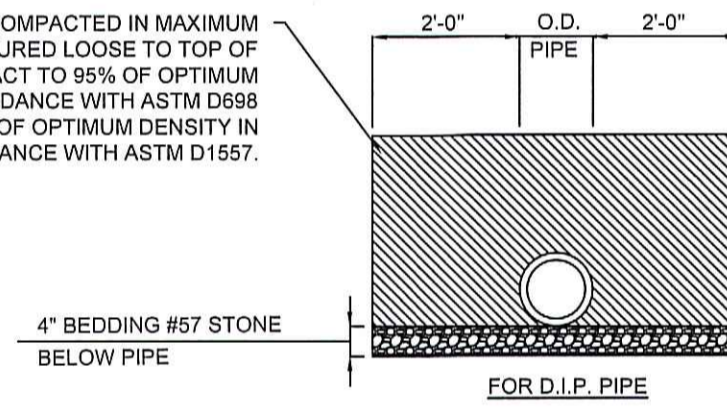

FOR D.I.P. PIPE

SELECT BACKFILL COMPACTED IN MAXIMUM 6" LAYERS MEASURED LOOSE TO TOP OF TRENCH. COMPACT TO 95% OF OPTIMUM DENSITY IN ACCORDANCE WITH ASTM D698 OR 92% OF OPTIMUM DENSITY IN ACCORDANCE WITH ASTM D1557.

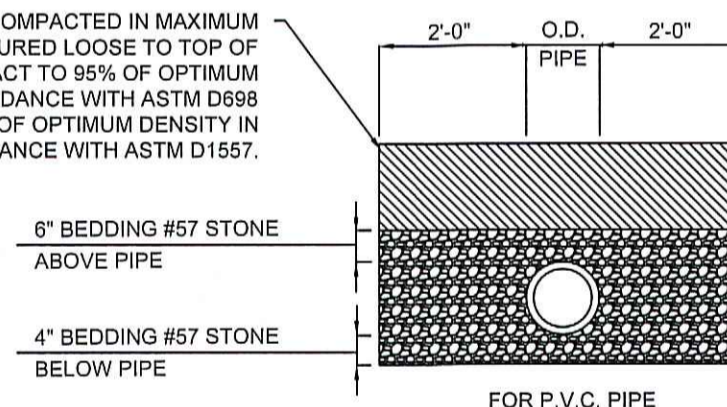

FOR P.V.C. PIPE

**UTILITY SERVICE TRENCHING AND BACKFILLING DETAIL**

N.T.S.

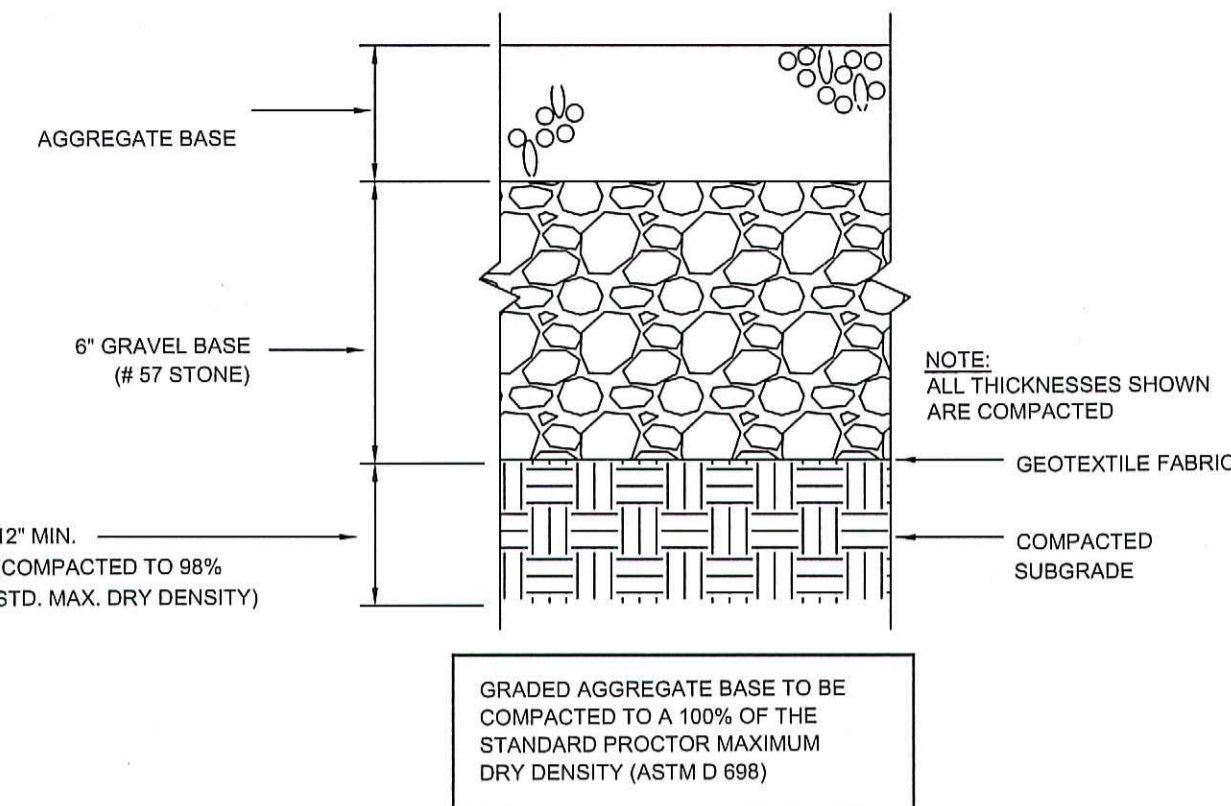

**TYPICAL GRAVEL SECTION DETAIL**

N.T.S.

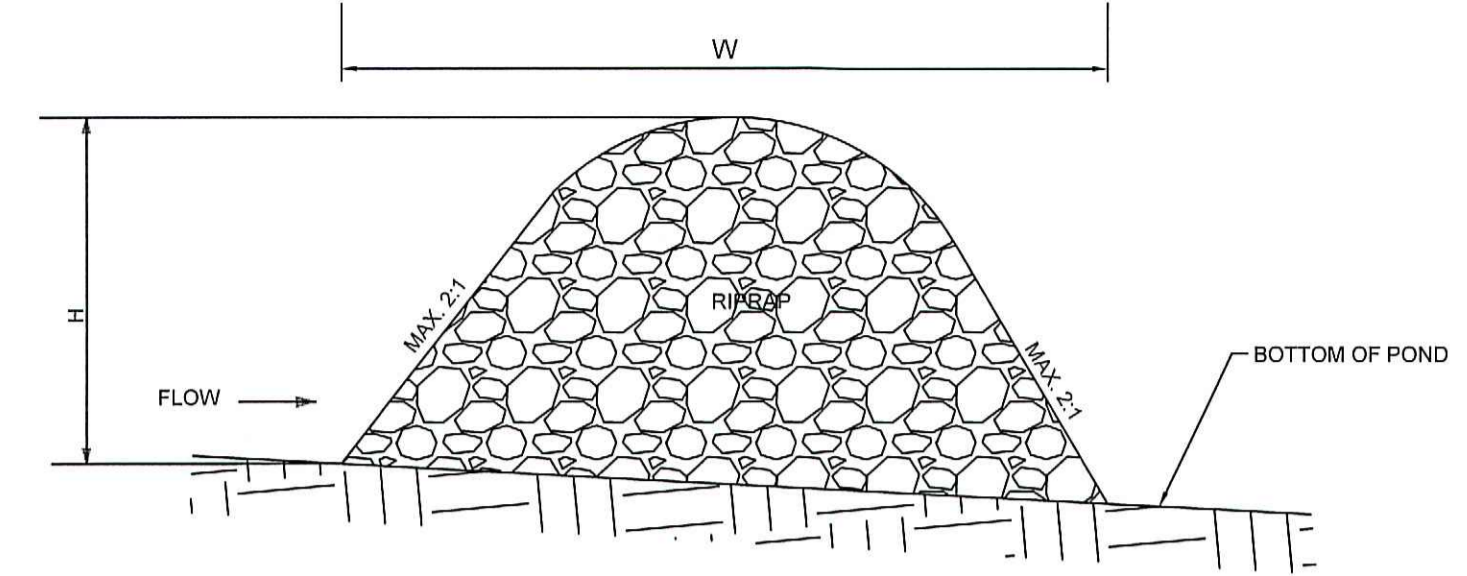

**FOREBAY NOTES:**

FOREBAY	FOREBAY HEIGHT (H)	FOREBAY WIDTH (W)	VOLUME (CF)
A	2'	11'	17,315
B	3'	15'	7,086
C	2.70'	14'	13,177
D	3'	15'	18,758

**FOREBAY DETAIL**

N.T.S.

REVISION DATE	

APPROVALS

ENGINEER	RTO	DESIGNER	RTO	TECHNICIAN	PRJ	CHECKED BY	GTF	APPROVED	RTO
----------	-----	----------	-----	------------	-----	------------	-----	----------	-----

DATE: 01/27/19

ALLIANCE CONSULTING ENGINEERS, INC.

1214 Verdae Blvd - Bonaventure II, Suite 505 - Greenville, SC 29607

Phone: (864) 284-1740 Fax: (864) 284-1741

**ALLIANCE CONSULTING ENGINEERS**

ALLIANCE CONSULTING ENGINEERS, INC.

1214 Verdae Blvd - Bonaventure II, Suite 505 - Greenville, SC 29607

Phone: (864) 284-1740 Fax: (864) 284-1741

PROJECT: CIVIL DESIGN PLANS FOR THE CLASS II C&D GREENPOINTE LANDFILL ALONG HAMLIN ROAD LOCATED IN ANDERSON COUNTY, SOUTH CAROLINA

SCALE: AS SHOWN

DATE: JUNE 2019

SHEET: C-8.2

FILE NAME: E16227-PLANS

REFERENCE FILE: E16227-BASE

PROJECT NO: 16227-0004